



**Facility Study
For
Generation Interconnection
Request
GEN-2010-041**

*SPP Generation
Interconnection Studies*

(#GEN-2010-041)

June 2013

Revision History

Date	Author	Change Description
6/10/2013	SPP	Facility Study Report Issued

Summary

Omaha Public Power District (OPPD) performed a detailed Facility Study at the request of Southwest Power Pool (SPP) for Generation Interconnection request GEN-2010-041 (10.5 MW/ Wind) located in Pawnee County, Nebraska. The originally proposed in-service date for GEN-2010-041 was December 31, 2011. Interconnection Service will require the Network Upgrades listed in the “Other Network Upgrades” section. The request for interconnection was placed with SPP in accordance with SPP’s Open Access Transmission Tariff, which covers new generation interconnections on SPP’s transmission system.

Phases of Interconnection Service

It is not expected that interconnection service will require phases however, interconnection service will not be available until all interconnection facilities and network upgrades can be placed in service.

Interconnection Customer Interconnection Facilities

The Interconnection Customer will be responsible for all of the transmission facilities connecting the customer owned substation to the Point of Interconnection (POI), at Omaha Public Power District (OPPD) owned 161kV bus at the Sub 1399 Substation. GEN-2010-041 will utilize the existing wind farm generator lead to Point of Interconnection (POI). The Interconnection Customer will also be responsible for any equipment located at the Customer substation necessary to maintain a power factor of 0.95 lagging to 0.95 leading at the POI.

Transmission Owner Interconnection Facilities and Non-Shared Network Upgrades

To allow interconnection the Transmission Owner will need to verify associated terminal equipment is acceptable for the addition of the Interconnection Customer’s Interconnection Facilities. At this time GEN-2010-041 is responsible for \$0.00 of Transmission Owner Interconnection Facilities and Non-Shared Network Upgrades.

Shared Network Upgrades

The Interconnection Customer was studied within the DISIS-2010-002 Impact Study. At this time, the Interconnection Customer is allocated \$0.00 for Shared Network Upgrades. If higher queued interconnection customers withdraw from the queue, suspend or terminate their GIA, restudies will have to be conducted to determine the Interconnection Customers’ allocation of Shared Network Upgrades. All studies have been conducted on the basis of higher queued interconnection requests and the upgrades associated with those higher queued interconnection requests being placed in service. At this time, the Interconnection Customer is allocated the following cost for Shared Network Upgrade:

Share Network Upgrade Description	Allocated Cost	Total Cost
None	\$0.00	\$0.00
Total	\$0.00	

Other Network Upgrades

Certain Other Network Upgrades are currently not the cost responsibility of the Customer but will be required for full Interconnection Service. No Other Network Upgrades are currently assigned to this request.

Depending upon the status of higher or equally queued customers, the Interconnection Customer's in-service date is at risk of being delayed or their Interconnection Service is at risk of being reduced until the in-service date of these Other Network Upgrades.

Conclusion

The Interconnection Customer is responsible for \$0.00 of Transmission Owner Interconnection Facilities and Non-Shared Network Upgrades. At this time, the Interconnection Customer is allocated \$0.00 for Shared Network Upgrades. After all Interconnection Facilities and Network Upgrades have been placed into service, Interconnection Service for 10.5 MW, as requested by GEN-2010-041, can be allowed. At this time the total allocation of costs assigned to GEN-2010-041 for Interconnection Service are estimated at \$0.00.



June 2013

Omaha Public Power District

**Facility Study for Southwest Power Pool
Generation Interconnection Request**

GEN-2010-041

Prepared By: OPPD Transmission Planning

This page intentionally left blank.

Table of Contents

Executive Summary	5
1. Introduction.....	10
2. Description of Requests	11
3. Steady State Analysis.....	14
3.1. Computer Programs.....	14
3.2. Methodology	14
3.3. Model Development.....	14
3.3.1. Benchmark Cases.....	14
3.3.2. Study Request Cases	15
3.4. Contingency Criteria	16
3.5. Monitored Elements	16
3.6. Reliability Margins.....	17
3.7. Performance Criteria	17
3.8. Contingency Analysis Results.....	18
3.8.1. System Intact Conditions	18
3.8.2. Single Event Contingencies	18
3.8.2.1. Thermal Impacts.....	18
3.8.2.2. Voltage Impacts.....	19
3.8.3. Prior Outage Contingencies	21
3.8.3.1. Thermal Impacts for Prior Outage Contingencies.....	21
3.8.3.2. Voltage Impacts for Prior Outage Contingencies	24
4. Short Circuit Study	27
4.1 Computer Programs	27
4.2 Methodology	27
4.3 Short-Circuit Model.....	28
4.5 Results.....	30
5. Mitigation Plans	31
5.1. NRIS and Prior Outage Related	31
5.1.1. Single-Event Contingency Interconnection Constraints.....	31
5.1.2. Prior Outage Contingency Interconnection Constraints	32
6. Power Factor Correction	34
7. Metering and Communication	34

8. Conclusion 34

Appendix A. Model Development for Steady-State Analysis 35

 A.1 Generation Projects 35

Appendix B. Modeling Data for GEN-2010-041 36

 B.1 Power Flow Model Data 36

 B.2 Short Circuit Wind Farm Parameters 38

Appendix C. Contingency Analysis Results 43

Appendix D. Full Substation Fault Current (kA) Comparison 362

Executive Summary

A Customer has requested a Facility Study under the Southwest Power Pool (SPP) Open Access Transmission Tariff (OATT) for the purpose of a 10.5 MW addition to an existing 60 MW wind generating facility interconnected to substation 1399 161kV, in Richardson County, Nebraska within the Balancing Authority Area of Omaha Public Power District (OPPD). The existing 60 MW wind generating facility interconnected to substation 1399 161 kV is called the Flat Water Wind Farm. The generation interconnection request for the 10.5 MW addition is SPP Generation Interconnection request GEN-2010-041. The generation interconnection request indicates that the rated output of the addition will be provided by seven GE 1.5 MW wind turbines. The generation interconnection request also indicates that the connection between the additional wind turbines and substation 1399 will be provided by the same 161/34.5 kV transformer that provides the connection between the existing wind turbines and substation 1399.

A System Impact Study was performed by SPP which evaluated the request to interconnect the additional 10.5 MW of generation at S1399. Initially studied as Network Resource Interconnection Service (NRIS), the System Impact Study completed in January 2011 (DISIS-2010-002) identified a requirement for the addition of a second 161/69kV autotransformer at the Humboldt 161kV substation.

The Customer later modified their interconnection request for Energy Resource Interconnection Service (ERIS) only (NRIS was removed). A subsequent System Impact Study completed in July 2011 (DISIS-2010-002-1), indicated that no network upgrades were required to accommodate the additional generation capacity at the S1399.

Generating Facility – GEN-2010-041

Pursuant to the SPP OATT and at the request of SPP, OPPD has performed the following Facility Study to satisfy the Facility Study Agreement executed by the requesting customer for SPP Generation Interconnection request GEN-2010-041. This request is for a 10.5 MW addition to an existing 60 MW wind farm in Richardson County, Nebraska.

Contingency Analysis

A steady-state contingency analysis was performed to identify constraints to interconnecting the proposed generating facility addition to the transmission system in accordance with NERC TPL-001, 002 & 003 Standards using SPP ERIS and NRIS impact criteria. The incremental impact of the GEN-2010-041 project to individual facilities was evaluated by comparing the steady-state performance of the transmission system in 2012 winter/spring/summer peak, and 2017 winter/summer peak without and with the GEN-2010-041 project.

System Intact Conditions

No ERIS or NRIS thermal or voltage constraints were identified for TPL-001 NERC category A (system intact) conditions.

Single-Event Contingencies

No thermal or voltage ERIS constraints were identified for TPL-002 NERC category B (single contingency) or TPL-003 NERC category C (multiple contingency) single event conditions.

NRIS thermal constraints under single event NERC category B and C contingencies were identified and are listed below. Since the customer only requested ERIS, these constraints are not required to be mitigated but are provided as information for potential constraints that may be identified in a Delivery study:

- Humboldt-S975 161-69 kV transformer
- BPS Sub7 - Clatona 115 kV line
- G10-47T – Harbine 115kV line
- S1263 T1 161-69kV transformer
- Clarinda – Nodaway 161kV line

No voltage ERIS or NRIS constraints were identified for NERC category B or C single event contingencies.

Prior Outage Contingencies

Various prior outage / contingency combinations were evaluated to support evaluating system performance. Constraints identified in this analysis are not required to be mitigated per SPP ERIS or NRIS criteria; however, these constraints identify potential operating limitations which may occur during certain planned outage work on the system. Identified thermal constraints for the prior outage / contingency combinations are listed below.

- Kelly 161-115-13.8 kV transformer
- Kelly-Tecumseh Hill 161 kV line
- Humboldt T2 161-115 kV transformer
- Humboldt – Steiner 115kV line
- Beatrice - Steiner 115kV line
- Kelly-King Hill 115 kV
- Circleville – King Hill 115kV
- Auburn Tap-S975 69 kV line
- Humboldt-S975 161-69 kV transformer

- Knob Hill – G09-40T 115kV
- BPS Sub7 - Clatona 115 kV line
- Midian 161-138 kV transformer
- Clatona – Sheldon 115kV line
- WM Bros – Midian 161kV line
- Tecumseh hill – WM Bros 161kV line
- G10-47T – Harbine 115kV line
- Clarinda – Nodaway 161kV line
- S1263 T1 161-69kV transformer

Mitigation Plans

The steady-state contingency analysis did not identify any ERIS constraints; therefore, there are not any required ERIS mitigation projects. There were some NRIS constraints and prior outage constraints. Potential mitigation plans for these NRIS and prior outage constraints are provided for informational purposes but are not required to accommodate the customer’s ERIS request.

NRIS & Prior Outage Constraints

There were five (5) NRIS thermal constraints identified for single event contingency conditions and eighteen (18) thermal constraints identified for prior outage contingency conditions. Potential mitigation plans for all of these constraints have been identified and are presented below:

Single-Event Contingency Interconnection Constraints

Additional 161/69 kV transformer capacity in the Southeast OPPD area could be added to mitigate the overloads of the OPPD Humboldt-S975 161/69 kV T4 transformer and the OPPD S1263 T1 161-69kV transformer.

Line re-conductor projects or line rebuilds could be used as mitigation options for the NPPD BPS Sub - Clatona 115 kV line, NPPD G10-47T – Harbine 115kV line and MIPU Clarinda – Nodaway 161kV line overloading issues.

Prior Outage Contingency Interconnection Constraints

All of the impacted facilities identified in the prior outage contingency analysis were significantly affected by the GEN-2010-041 wind facility during prior outage conditions. In real-time operations when the problematic prior outage conditions listed in this report occur, the GEN-2010-041 wind facility may be subject to output restrictions by an amount sufficient to mitigate its impacts on the impacted facilities listed above.

Short Circuit Analysis & Results

OPPD, NPPD, and Westar each performed an evaluation to determine whether any of their circuit breakers would not have adequate interrupting capability with the GEN-2010-041 project based on short-circuit results for a transmission-system topology of all branches in service. This review by OPPD, NPPD and Westar uncovered no breakers whose interrupting capability would potentially be inadequate.

Power Factor Correction

The SPP System Impact Study completed in July 2011 (DISIS-2010-002-1) established the final power factor requirement at the point of interconnection (S1399) for GEN-2010-041 to be 0.965 leading/lagging.

The existing 60 MW wind farm and 10.5 MW addition both share the same 161/34.5 kV generator step-up transformer (GSU) which is rated for 75 MVA. It is assumed that the 60 MW and 10.5 MW wind turbines have a 0.9 leading/lagging power factor capability. For this assumption the maximum MVA output capability of the combined wind farm is 78.3 MVA. If approximately 1.8 MVA is attributed to losses between the turbines and the 34.5 kV bus, then there is a potential to overload the existing 161/34.5 kV GSU by 102% (76.5 MVA).

For conditions when the total wind farm generation output is at its maximum MVA generating capability and is producing reactive power to support voltage at S1399, there is a potential to overload the 161/34.5 kV GSU. This was observed in OPPD sensitivity studies where the voltage schedule was adjusted for GEN-2010-041. This issue can be mitigated by reducing the voltage schedule at S1399.

Metering and Communication

The wind farm developer for GEN-2010-041 will be required to adhere to OPPD metering and communication requirements in order to separate this 10.5 MW addition from OPPD's existing 60 MW portion of the combined 70.5 MW wind generating facility. The details of the metering and communication requirements will be addressed in the generation interconnection agreement (GIA) for GEN-2010-041.

Conclusion

This report presents the results of steady-state contingency analysis and short-circuit analysis performed to evaluate the interconnection impacts of the GEN-2010-041 wind facility in accordance with NERC TPL-001, 002 & 003 Standards using SPP ERIS and NRIS impact criteria. There are not any constraints or associated mitigation requirements to accommodate the customer's ERIS request. There were some constraints identified for the NRIS evaluation and for prior outage conditions. Potential mitigation plans for these NRIS and prior outage constraints were identified and provided for information. The wind farm developer for GEN-2010-041 will be required to adhere to OPPD metering and communication requirements in order to separate the 10.5 MW addition from

OPPD's existing 60 MW portion of the combined 70.5 MW wind generating facility. Metering and communication requirements will be outlined in the GIA for GEN-2010-041.

1. Introduction

A Facilities Study has been performed to evaluate the interconnection of a 10.5 MW addition to an existing 60 MW wind generating facility interconnected to substation 1399 161kV, in Richardson County, Nebraska within the Balancing Authority Area of Omaha Public Power District (OPPD). The existing 60 MW wind generating facility interconnected to substation 1399 161 kV is called the Flat Water Wind Farm. The generation interconnection request for the 10.5 MW addition is SPP Generation Interconnection request GEN-2010-041. The generation interconnection request indicates that the rated output of the addition will be provided by seven GE 1.5 MW wind turbines. The generation interconnection request also indicates that the connection between the additional wind turbines and substation 1399 will be provided by the same 161/34.5 kV transformer that provides the connection between the existing wind turbines and substation 1399.

A System Impact Study was performed by SPP which evaluated the request to interconnect the additional 10.5 MW of generation at S1399. Initially studied as Network Resource Interconnection Service (NRIS), the System Impact Study completed in January 2011 (DISIS-2010-002) identified a requirement for the addition of a second 161/69kV autotransformer at the Humboldt 161kV substation.

The Customer later modified their interconnection request for Energy Resource Interconnection Service (ERIS) only (NRIS was removed). A subsequent System Impact Study completed in July 2011 (DISIS-2010-002-1), indicated that no network upgrades were required to accommodate the additional generation capacity at the S1399.

The Interconnection Customer has requested the 10.5 MW wind generating facility be evaluated as an ERIS request which has been considered for this assessment. The Interconnection Customer will be responsible for its 161/34.5kV substation that will contain its step down transformers and wind turbine collector feeders.

This Facility Study has the following objectives:

- Identify constraints to interconnection of the proposed wind generating facility;
- Identify network upgrades needed to support interconnection of the proposed wind generating facility;
- Document the impact of the proposed wind generating facility on branch loading, bus voltages and system stability;
- Document equipment short-circuit duties in a report for submittal to Affected Systems

This study was performed by OPPD with consideration to queued generation interconnection projects in the local area near the point of interconnection. The report will present the results of steady-state contingency and short-circuit analyses.

2. Description of Requests

The Interconnection Customer has requested to interconnect a 10.5 MW wind generating facility to the OPPD transmission system. The customer proposes to interconnect at S1399 161kV located approximately 10 miles south of the Humboldt substation on the Humboldt – Kelly 161 kV line. The customer has also requested the 10.5 MW wind generating facility be evaluated as an ERIS request.



Figure 2-1: Geographic Location of the GEN-2010-041 Point of Interconnection

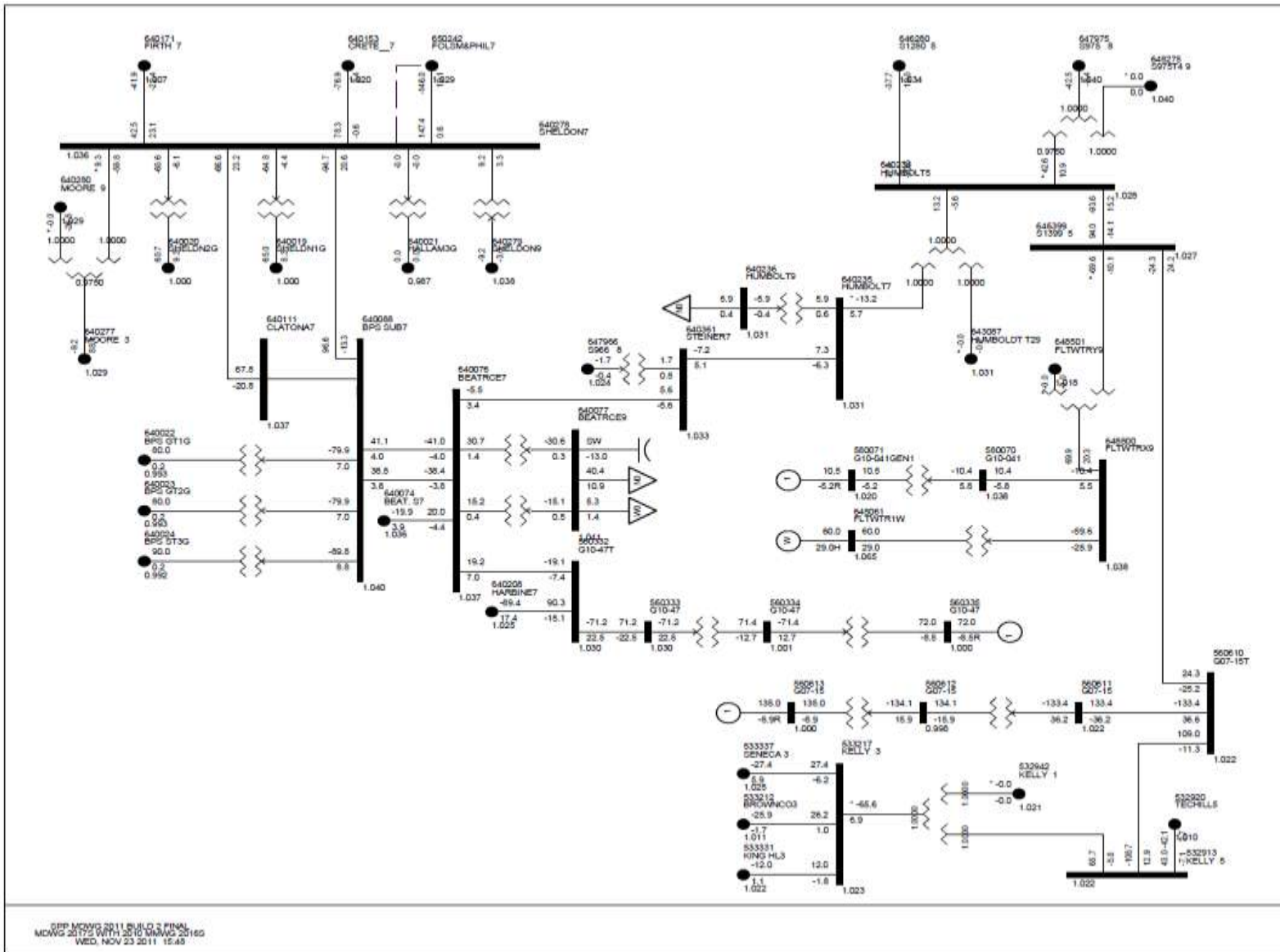

Figure 2-2: OPP GEN-2010-041 Interconnection One-Line Diagram

The GEN-2010-041 project has a rated output of 10.5 MW provided by 7 GE 1.5MW wind turbines. The generating facility is modeled using one equivalent generator connected as shown in Figure 2-3. The powerflow modeling data used in this study to model the wind farms in the SPP interconnection queue was obtained from SPP.

The GEN-2010-041 wind farm model and parameters are documented in Section B.1 of Appendix B.

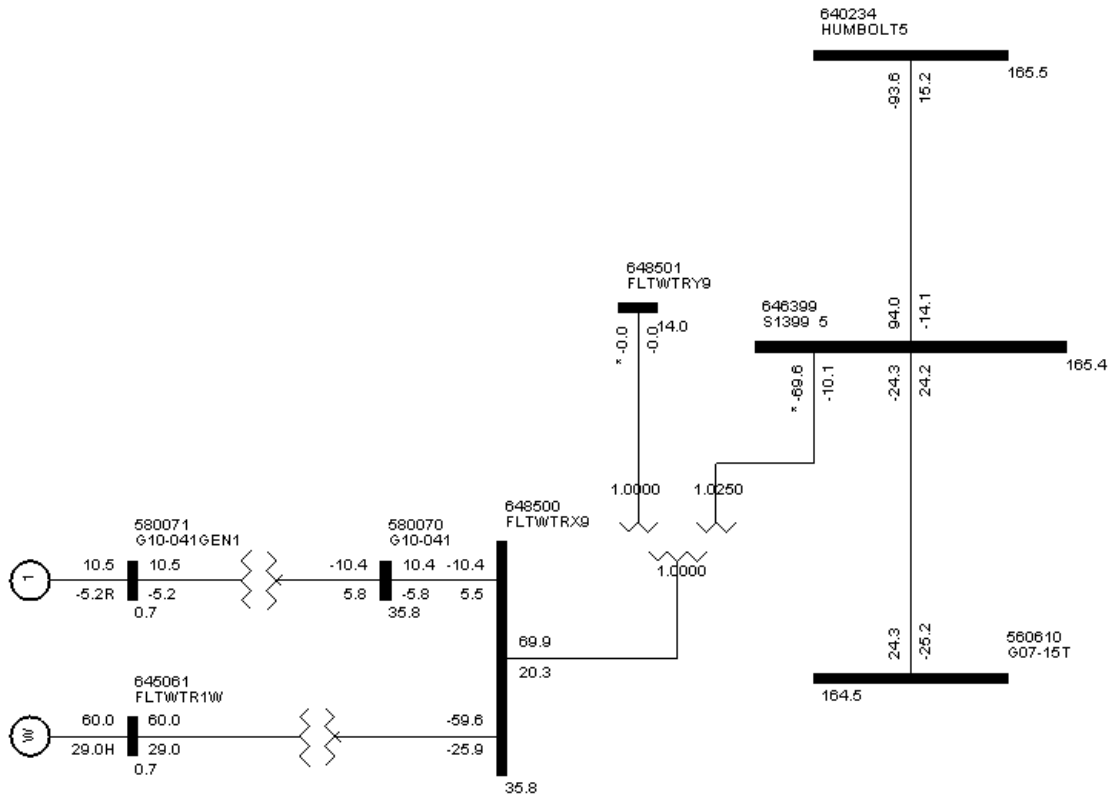

Figure 2-3: GEN-2010-041 Conceptual One-Line Diagram

3. Steady State Analysis

3.1. Computer Programs

Steady-state analysis was performed using PSS®E version 30.3.2.

3.2. Methodology

Benchmark cases representing system conditions in 2012 winter/spring/summer peak, and 2017 winter/summer peak were created without the GEN-2010-041 project. Study cases were created by adding the GEN-2010-041 project and dispatching the generating facility at 10.5 MW. Nonlinear (AC) contingency analysis was performed on both the benchmark and study cases and the incremental impact of the GEN-2010-041 project was evaluated by comparing flows and voltages without and with the proposed interconnection.

3.3. Model Development

3.3.1. Benchmark Cases

The SPP MDWG 2011 model series includes models representing winter peak conditions in 2012 and 2017, spring peak conditions in 2012 and summer peak conditions in 2012 and 2017. Benchmark cases without the GEN-2010-041 project were developed from the MDWG models by applying the model updates provided by SPP, OPD or local Balancing Authorities (BA).

The benchmark cases include relevant prior queued generating facilities, which are listed in Appendix A.1. The following generating facilities are within the geographic area of the GEN-2010-041 point of interconnection and are dispatched as follows:

- ASGI-2010-001 (AECI) - 100% of 400 MW
- ASGI-2010-005 (AECI) - 100% of 99 MW
- ASGI-2010-009 (AECI) - 100% of 201 MW
- GEN-2006-014 (MIPU) - 100% of 300 MW
- GEN-2006-017 (MIPU) - 100% of 300 MW
- GEN-2007-015 (WERE) - 100% of 135 MW
- GEN-2007-017 (MIPU) - 100% of 100.5 MW
- GEN-2007-053 (MIPU) - 100% of 110 MW
- GEN-2010-041 (OPPD) - 100% of 10.5 MW
- GEN-2010-047 (NPPD) - 100% of 72 MW

- GEN-2009-040 (WERE) - 100% of 73.8 MW
- J133 (MEC) - 100% of 100.5 MW
- R26 (MEC) - 100% of 400 MW

It should be noted that the conditions utilized for the steady state study represent worst-case generation outlet conditions. This was done to stress generator outlet capacity at the maximum accredited generation for the study cluster. Since all prior queued projects were modeled at 100% of their nameplate rating, thermal loading contributions to facilities created by these projects is possible but unlikely.

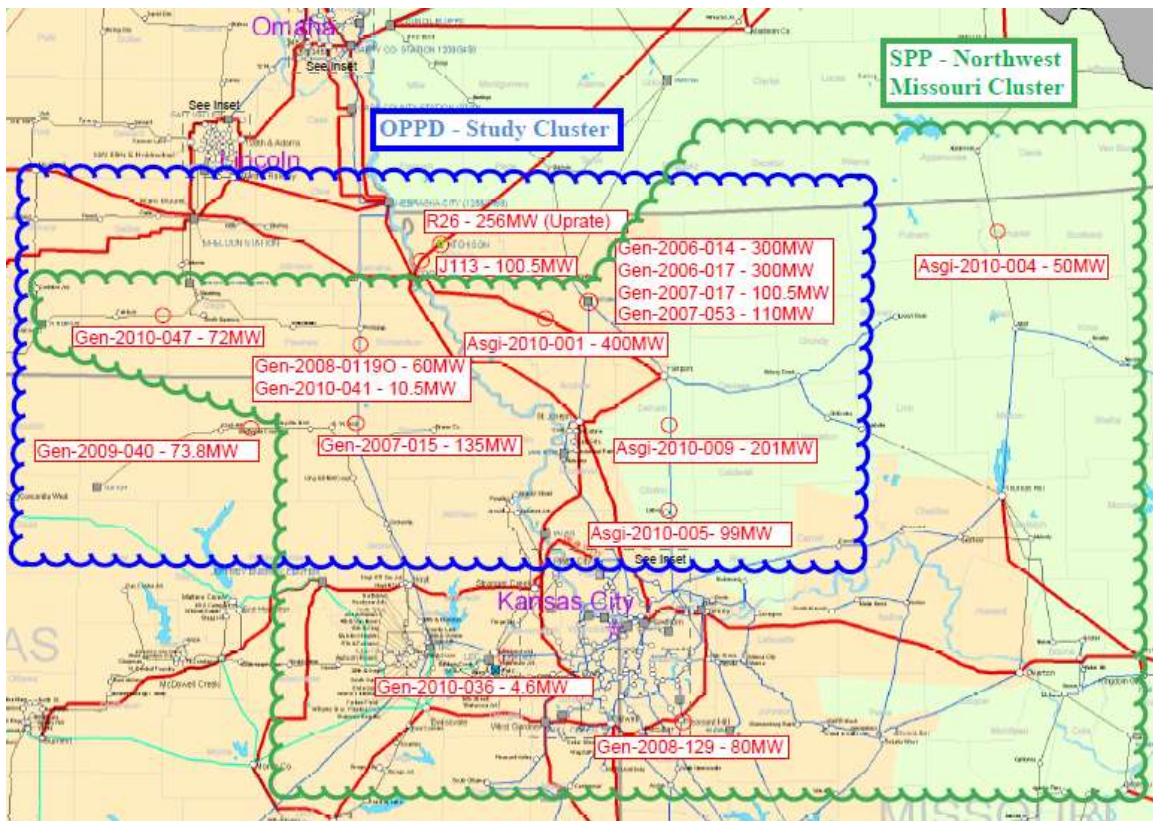

Figure 3-1: GEN-2010-041 OPPD Study Cluster

Cases were solved with transformer tap adjustment enabled, area interchange disabled, phase shifter adjustment enabled and switched shunt adjustment enabled.

3.3.2. Study Request Cases

The GEN-2010-041 generating facility was added to each benchmark case as described in Section 2. The generating facility was dispatched to OPPD generators outside of the geographic area that are in service. Dispatch details are provided in Section B.1 of Appendix B, Tables B-1 through B-5.

3.4. Contingency Criteria

A variety of contingencies were considered for steady-state analysis:

- NERC Category A with system intact (no contingencies)
- NERC Category B
 - Single element outages, at buses with a nominal voltage of 100 kV and above, in the following areas: ALTW (area 627), LES (area 650), MEC (area 635), NPPD (area 640), OPPD (area 645), WAPA (zone 1604 and buses 652603 & 631069), WERE (area 536), KCPL (area 541), MIPU (area 540), AECI (area 330)
 - Single element outages, at all buses in the OPPD (area 645) control area
 - Multi-element outages initiated by a fault with normal clearing such as multi-terminal lines, in and around OPPD's area
- NERC Category C
 - Any two circuits of a common tower line, in and around OPPD's area
 - Selected bus section and breaker failure contingencies in and around OPPD's area
 - Selected prior outages near the point of interconnection followed by category B contingencies or single event category C contingencies.

For all contingency and post-disturbance analyses, cases were solved with transformer tap adjustment disabled (fixed), area interchange adjustment disabled, phase shifter adjustment disabled (fixed) and switched shunt adjustment disabled (fixed).

Prior outages were selected to produce more severe system impacts. Analysis considered the prior outages listed below.

- S1399 – Humboldt 161 kV line
- GEN-2007-015 Nemaha Wind Facility – Kelly 161 kV line
- Humboldt – S1280 161 kV line
- S975 (Humboldt) T4 161/69 kV transformer

3.5. Monitored Elements

The study area is defined in Table 3-1. Facilities in the study area were monitored for system intact and contingency conditions. Under NERC category A, B and C conditions branches were monitored for loading above the normal (PSS®E rate A) rating as shown in the column labeled "Contingency Thermal Limits".

Table 3-1: Monitored Elements

Area	Monitored Facilities	Contingency Thermal Limits	Bus Voltage Limits
ALTW	100 kV and above	100% of Rate A	1.05/0.95
LES	100 kV and above	100% of Rate A	1.05/0.95
MEC	100 kV and above	100% of Rate A	1.05/0.95
NPPD	100 kV and above	100% of Rate A	1.05/0.95
OPPD	69 kV and above	100% of Rate A	1.05/0.95
WAPA	Zone 1604 and buses 652603 & 631069	100% of Rate A	1.05/0.95
WERE	100 kV and above	100% of Rate A	1.05/0.95
KCPL	100 kV and above	100% of Rate A	1.05/0.95
MIPU	100 kV and above	100% of Rate A	1.05/0.95
AECI	100 kV and above	100% of Rate A	1.05/0.95

3.6. Reliability Margins

All system elements were monitored using 100% of the applicable normal rating.

3.7. Performance Criteria

A branch is considered a significantly affected facility (SAF) if both of the following conditions are met:

- 1) The branch is loaded above its applicable normal or emergency rating for the post-change case.
- 2) The distribution factor is greater than 3% for NRIS or greater than 20% for ERIS.

For non-linear contingency analysis, distribution factors are calculated as follows:
Project MW

$$DF = 100 \times \frac{MVA \text{ flow with Project} - MVA \text{ flow (w/o Project)}}{Project MW}$$

A voltage impact is considered significant if both of the following conditions are met; all significant voltage impacts must be resolved before a project can receive interconnection service.

- 1) The bus voltage is outside of applicable normal or emergency limits for the

- post-change case.
- 2) The change in bus voltage is greater than 0.01 per unit.

3.8. Contingency Analysis Results

The incremental impact of the proposed interconnection on individual facilities was evaluated by comparing flows and voltages without and with the project. Analysis was performed using PSS®E activity ACCC.

3.8.1. System Intact Conditions

No significant thermal or voltage impacts were identified for NERC category A (pre-contingency) conditions.

3.8.2. Single Event Contingencies

The results in this section are for analysis of conditions following NERC Category B contingencies and Category C contingencies with a single initiating event such as a breaker failure or a fault on any two circuits of a multiple circuit towerline.

3.8.2.1. Thermal Impacts

No thermal ERIS constraints were identified for TPL-002 NERC category B (single contingency) or TPL-003 NERC category C (multiple contingency) single event conditions.

There were thermal NRIS constraints which are listed below and in Appendix C, Tables C-1, C-2, C-3, C-4 and C-5. The highest loading of each facility on which the GEN-2010-041 project has a significant thermal impact is shown in Table 3-2.

The facilities listed below are considered NRIS constraints for the GEN-2010-041 project:

- Humboldt-S975 161-69 kV transformer
- BPS Sub - Clatona 115 kV line
- G10-47T – Harbine 115kV line
- S1263 T1 161-69kV transformer
- Clarinda – Nodaway 161kV line

The Humboldt-S975 161-69 kV transformer is an NRIS constraint and is a significantly affected facility in the 2012 and 2017 summer and winter cases. The transformer loading exceeds the 67.2 MVA rating for two category B and two category C contingencies. The highest loading is approximately 83.4 MVA (124.1% of 67.2 MVA rating) for the failure of a 161 kV circuit breaker at bus S1263.

The BPS Sub-Clatona 115 kV line is an NRIS constraint and is a significantly affected facility in the 2012 winter and spring and 2017 winter cases. The line loading exceeds the 137 MVA rating for one category B contingency. The highest loading is approximately 141.4 MVA (103.2% of 137 MVA rating) when BPS Sub-Sheldon 115 kV line is out of service.

The G10-47T-Harbine 115 kV line is an NRIS constraint and is a significantly affected facility in the 2012 summer case. The line loading exceeds the 99 MVA rating for one category B contingency. The highest loading is approximately 102.2 MVA (103.2% of 99 MVA normal rating) when the Kelly – Gen-2007-015 161 kV line is out of service.

The S1263 T1 161-69kV transformer is an NRIS constraint and is a significantly affected facility in the 2012 and 2017 winter cases. The line loading exceeds the 106 MVA rating for one category B contingency and one category C contingency. The highest loading is approximately 111.9 MVA (105.6% of 106 MVA rating) for the loss of the Humboldt-S975 161-69kV transformer.

The Clarinda – Nodaway 161 kV line is an NRIS constraint and is a significantly affected facility in the 2012 summer, winter and spring and 2017 summer and winter cases. The line loading exceeds the 167 MVA rating for various category B and C contingencies. The highest loading is approximately 310.1 MVA (185.7 % of 167 MVA rating) when the Maryville – Creston 161 kV line is out of service.

3.8.2.2. Voltage Impacts

No voltage ERIS or NRIS constraints were identified following NERC Category B contingencies or Category C contingencies with a single initiating event.

Table 3-2: Thermal Violations, Single-Event Contingencies, Maximum Screened Loading

Monitored Element	Rating MVA	Pre-Project Loading (%)	Post-Project Loading (%)	DF (%)	Contingency	Type	Case
640088 BPS SUB7 115 640111 CLATONA7 115 1 NPPD	137	102.6	103.2	7.6	OPEN 640088 BPS SUB7 115 TO 640278 SHELDON7 115 1	B	12G
560332 G10-47T 115 640208 HARBINE7 115 NPPD	99	102.7	103.2	4.8	OPEN 532913 KELLY 5 161 TO 560610 G07-15T 161 1	B	12S
640234 HUMBOLT5 161 3WINDTR S975 T4 WND OPPD	67.2	115.5	116.8	8.6	OPEN 646263 S1263 5 161 TO 646280 S1280 5 161 1	B	17W
640234 HUMBOLT5 161 3WINDTR S975 T4 WND OPPD	67.2	123.2	124.1	5.7	CB1263-BUS OPEN 646263 S1263 5 161 TO 646280 S1280 5 161 1 OPEN 646263 S1263 5 161 TO 647111 W BROCK8 69 TO 648263 S1263T19 13.8 1 OPEN 646263 S1263 5 161 TO 646258 S1258 5 161 1	C	17W
646263 S1263 5 161 3WINDTR S1263 T1 WND OPPD	106	105.1	105.6	4.8	OPEN 640234 HUMBOLT5 161 TO 647975 S975 8 69 TO 648275 S975T4 9 13.8 1	B	17W
646263 S1263 5 161 3WINDTR S1263 T1 WND OPPD	106	102.8	103.2	4.8	CB975-T4-965 OPEN 640234 HUMBOLT5 161 TO 647975 S975 8 69 TO 648275 S975T4 9 13.8 1 OPEN 647975 S975 8 96 TO 647965 S965 8 69 1	C	17W
635034 CLRNDA 5 161 560001 NODAWAYCO 161 MIPU	167	185.4	185.7	3.8	OPEN 300097 5MARYVL 161 TO 652560 CRESTON5 161 1	B	12W
635034 CLRNDA 5 161 560001 NODAWAYCO 161 MIPU	153	160.9	161.2	3.8	CBCB-CB3-RL OPEN 635000 CBLUFFS3 345 TO BUS 635100 RLHILLS3 345 CKT 1 OPEN 635000 CBLUFFS3 345 TO BUS 635023 CBLUF33G 345 CKT 1	C	12S

3.8.3. Prior Outage Contingencies

Constraints identified in this section are not required to be mitigated per SPP ERIS or NRIS criteria; however, these constraints identify potential operating limitations which may occur during certain planned outage work on the system.

The results in this Section are for analysis of the following conditions:

- In each season case, under the selected prior outage (Category B) condition, subsequent category B and single event category C contingencies are applied

3.8.3.1. Thermal Impacts for Prior Outage Contingencies

There were thermal constraints which are listed below and in Appendix C, Tables C-6, and C-7. The highest loading of each facility on which the GEN-2010-041 project has a significant thermal impact is shown in Table 3-3.

The GEN-2010-041 project has a significant impact on the facilities listed.

- Kelly 161-115-13.8 kV transformer
- Kelly-Tecumseh Hill 161 kV line
- Humboldt T2 161-115 kV transformer
- Humboldt – Steiner 115kV line
- Beatrice - Steiner 115kV line
- Kelly-King Hill 115 kV
- Circleville – King Hill 115kV
- Auburn Tap-S975 69 kV line
- Humboldt-S975 161-69 kV transformer
- Knob Hill – G09-40T 115kV
- BPS Sub7 - Clatona 115 kV line
- Midian 161-138 kV transformer
- Clatona – Sheldon 115 kV line
- WM Bros – Midian 161kV line
- Tecumseh hill – WM Bros 161kV line
- G10-47T – Harbine 115kV line
- Clarinda – Nodaway 161kV line
- S1263 T1 161-69kV transformer

The Kelly 161-115-13.8 kV transformer is a significantly affected facility in the 2012 spring and summer cases. Impacts violate performance criteria for one prior outage/contingency pair involving prior outage of the S1399-Humboldt 161 kV line. The highest loading is approximately 203.6 MVA (121.2% of the 168 MVA rating) when the S1399 - Humboldt 161 kV line and Kelly-Tecumseh Hill 161 kV line are both out of service.

The Kelly-Tecumseh Hill 161 kV line is a significantly affected facility in the 2012 spring and summer cases. Impacts violate performance criteria for one prior outage/contingency pair involving prior outage of the S1399-Humboldt 161 kV line. The highest loading is approximately 204.5 MVA (127% of the 161 MVA rating) when the S1399 - Humboldt 161 kV line and Kelly 161-115-13.8 kV transformer are both out of service.

The Humboldt T2 161-115-13.8 kV transformer is a significantly affected facility in the 2012 spring and summer cases. Impacts violate performance criteria for one prior outage/contingency pair involving prior outage of the GEN-2007-015 Nemaha Wind Facility – Kelly 161 kV line. The highest loading is approximately 202.1 MVA (160.4% of the 126 MVA rating) when the GEN-2007-015 Nemaha Wind Facility – Kelly 161 kV line is out and for the failure of a 161 kV circuit breaker at Humboldt.

The Humboldt-Steiner 115 kV line is a significantly affected facility in the 2012 spring and summer cases. Impacts violate performance criteria for one prior outage/contingency pair involving prior outage of the GEN-2007-015 Nemaha Wind Facility – Kelly 161 kV line. The highest loading is approximately 199.2 MVA (166% of the 120 MVA rating) when the GEN-2007-015 Nemaha Wind Facility – Kelly 161 kV line is out and for the failure of a 161 kV circuit breaker at Humboldt.

The Beatrice-Steiner 115 kV line is a significantly affected facility in the 2012 spring and summer cases. Impacts violate performance criteria for one prior outage/contingency pair involving prior outage of the GEN-2007-015 Nemaha Wind Facility – Kelly 161 kV line. The highest loading is approximately 200.3 MVA (166.9% of the 120 MVA rating) when the GEN-2007-015 Nemaha Wind Facility – Kelly 161 kV line is out and for the failure of a 161 kV circuit breaker at Humboldt.

The Kelly-King Hill 115 kV line is a significantly affected facility in the 2012 spring and summer case. Impacts violate performance criteria for one prior outage/contingency pair involving prior outage of the S1399-Humboldt 161 kV line. The highest loading is approximately 119.1 MVA (129.5% of the 92 MVA rating) when the S1399 - Humboldt 161 kV line and Kelly-Tecumseh Hill 161 kV line are both out of service.

The Circleville-King Hill 115 kV line is a significantly affected facility in the 2012 spring and summer case. Impacts violate performance criteria for one prior outage/contingency pair involving prior outage of the S1399-Humboldt 161 kV line. The highest loading is approximately 117.1 MVA (127.3% of the 92 MVA rating) when the S1399 - Humboldt 161 kV line and Kelly-Tecumseh Hill 161 kV line are both out of service.

The Auburn Tap-S975 69 kV line is a significantly affected facility in the 2012 spring and summer cases. Impacts violate performance criteria for two prior outage/contingency pairs involving prior outage of the Humboldt-S1280 or S1399-Kelly 161 kV lines. The highest loading is approximately 93.6 MVA (130% of the 72 MVA rating) when the

S1399-Kelly 161 kV line is out and for the failure of a 161 kV circuit breaker at S1280 161 kV.

The Humboldt-S975 161-69 kV transformer is a significantly affected facility in the 2012 spring and summer cases. Impacts violate performance criteria for two prior outage/contingency pairs involving prior outage of the Humboldt-S1280 or S1399-Kelly 161 kV lines. The highest loading is approximately 112.9 MVA (168% of the 67.2 MVA rating) when the S1399-Kelly 161 kV line is out and for the failure of a 161 kV circuit breaker at S1280 161 kV.

The Knob Hill- G09-40T 115 kV line is a significantly affected facility in the 2012 spring and summer case. Impacts violate performance criteria for one prior outage/contingency pair involving prior outage of the S1399-Humboldt 161 kV line. The highest loading is approximately 106 MVA (115.2% of the 92 MVA rating) when the S1399 - Humboldt 161 kV line and Kelly-Tecumseh Hill 161 kV line are both out of service.

The BPS Sub- Clatona 115 kV line is a significantly affected facility in the 2012 spring case. Impacts violate performance criteria for four prior outage/contingency pairs involving prior outage of the S1399 – Humboldt 161 kV line, GEN-2007-015 Nemaha Wind Facility – Kelly 161 kV line, Humboldt – S1280 161 kV line or the S975 (Humboldt) T4 161/69 kV transformer. The highest loading is approximately 149.6 MVA (109.2% of the 137 MVA rating) when the S1280 - Humboldt 161 kV line and BPS Sub-Sheldon 115 kV line are both out of service.

The Midian 161-138-12.47 kV transformer is significantly affected facility in the 2012 spring case. Impacts violate performance criteria for one prior outage/contingency pair involving prior outage of the S1399-Kelly 161 kV line. The highest loading is approximately 91.5 MVA (115.8% of the 79 MVA rating) when the S1399-Kelly 161 kV line and Empec-Wichita 345kV are both out of service.

The Clatona – Sheldon 115kV line is significantly affected facility in the 2012 spring case. Impacts violate performance criteria for one prior outage/contingency pair involving prior outage of the S1280-Humboldt 161 kV line. The highest loading is approximately 143.6 MVA (104.8% of the 137 MVA rating) when the S1280-Humboldt 161 kV line and BPS Sub-Sheldon 115 kV line are both out of service.

The WM Bros – Midian 161kV line is significantly affected facility in the 2012 spring case. Impacts violate performance criteria for one prior outage/contingency pair involving prior outage of the S1399-Humboldt 161 kV line. The highest loading is approximately 93.2 MVA (110.9% of the 84 MVA rating) when the S1399-Humboldt 161 kV line and JEC N-Summit 345 kV line are both out of service.

The Tecumseh hill – WM Bros 161kV line is significantly affected facility in the 2012 spring case. Impacts violate performance criteria for one prior outage/contingency pair involving prior outage of the S1399-Humboldt 161 kV line. The highest loading is

approximately 96.4 MVA (114.8% of the 84 MVA rating) when the S1399-Humboldt 161 kV line and Empec-Wichita 345kV are both out of service.

The G10-47T- Harbine 115 kV line is a significantly affected facility in the 2012 spring and summer case. Impacts violate performance criteria for three prior outage/contingency pairs involving prior outage of the GEN-2007-015 Nemaha Wind Facility – Kelly 161 kV line, Humboldt – S1280 161 kV line or the S975 (Humboldt) T4 161/69 kV transformer. The highest loading is approximately 129 MVA (130.3% of the 99 MVA rating) when the GEN-2007-015 Nemaha Wind Facility – Kelly 161 kV line is out and for failure of a 161 kV circuit breaker at Humboldt.

The Clarinda – Nodaway 161kV line is a significantly affected facility in the 2012 spring and summer cases. Impacts violate performance criteria for four prior outage/contingency pairs involving prior outage of the S1399 – Humboldt 161 kV line, GEN-2007-015 Nemaha Wind Facility – Kelly 161 kV line, Humboldt – S1280 161 kV line or the S975 (Humboldt) T4 161/69 kV transformer. The highest loading is approximately 415.5 MVA (271.6% of the 153 MVA rating) when the S1399 - Humboldt 161 kV line and Maryville - Nodaway 161kV line are both out of service.

The S1263 T1 161-69kV transformer is a significantly affected facility in the 2012 summer case. Impacts violate performance criteria for two prior outage/contingency pairs involving prior outage of the GEN-2007-015 Nemaha Wind Facility – Kelly 161 kV line or the S975 (Humboldt) T4 161/69 kV transformer. The highest loading is approximately 115 MVA (108.5% of the 106 MVA rating) when the GEN-2007-015 Nemaha Wind Facility – Kelly 161 kV line and Humboldt-S975 161-69 kV transformer are both out of service.

3.8.3.2. Voltage Impacts for Prior Outage Contingencies

No significant voltage impacts were identified following NERC Category B contingencies or Category C contingencies with a single initiating event.

Table 3-3: Thermal Violations, Prior Outage Contingencies, Maximum Screened Loading

Monitored Element	Rating MVA	Pre-Project Loading (%)	Post-Project Loading (%)	DF (%)	Contingency	Type	Case
640088 BPS SUB7 115 640111 CLATONA7 115 1	137	107.7	109.2	20.0	Prior: (\$1280 to Humboldt) OPEN 640088 BPS SUB7 115 TO 640278 SHELDON7 115 1	B	12G
640111 CLATONA7 115 640278 SHELDON7 115 1	137	103.3	104.8	19.0	Prior: (\$1280 to Humboldt) OPEN 640088 BPS SUB7 115 TO 640278 SHELDON7 115 1	B	12G
533217 KELLY 3 115 3WINDTR KELLY 1X WND 1	168	115	121.2	100.0	Prior: (\$1399 to Humboldt) OPEN 532913 KELLY 5 161 TO 532920 TECHILL5 161 1	B	12G
533217 KELLY 3 115 533331 KING HL3 115 1	92	121.8	129.5	61.0	Prior: (\$1399 to Humboldt) OPEN 532913 KELLY 5 161 TO 532920 TECHILL5 161 1	B	12G
533152 CIRCLVL3 115 533331 KING HL3 115 1	92	119.6	127.3	60.0	Prior: (\$1399 to Humboldt) OPEN 532913 KELLY 5 161 TO 532920 TECHILL5 161 1	B	12G
532990 MIDIAN 4 138 3WINDTR MIDIAN3X WND	79	115.2	115.8	4.8	Prior: (\$1399 to Humboldt) OPEN 532768 EMPEC 7 345 TO 532796 WICHITA7 345 1	B	12G
532920 TECHILL5 161 532921 WM BROS5 161 1	84	114.1	114.8	3.8	Prior: (\$1399 to Humboldt) OPEN 532768 EMPEC 7 345 TO 532796 WICHITA7 345 1	B	12G
532921 WM BROS5 161 532936 MIDIAN 5 161 1	84	110.1	110.9	3.8	Prior: (\$1399 to Humboldt) OPEN 532766 JEC N 7 345 TO 532773 SUMMIT 7 345 1	B	12G
640235 HUMBOLT7 115 3WINDTR HUMBOLDT T2 WND	126	152.6	160.4	93.3	Prior: (Kelly to Nemaha Wind Farm GEN-2007-015) CBHUM-80&T4 OPEN 640234 HUMBOLTS 161 TO 647975 S975 8 69 TO 648275 S975T4 9 13.8 1 OPEN 640234 HUMBOLTS 161 TO 646280 S1280 5 161 1	C	12G
640076 BEATRCE7 115 640361 STEINER7 115 1	120	156.2	166.9	86.7	Prior: (Kelly to Nemaha Wind Farm GEN-2007-015) CBHUM-80&T4 OPEN 640234 HUMBOLTS 161 TO 647975 S975 8 69 TO 648275 S975T4 9 13.8 1 OPEN 640234 HUMBOLTS 161 TO 646280 S1280 5 161 1	C	12G
647101 AUBRNT 8 69 647975 S975 8 69 1	72	123.8	130	34.3	Prior: (Kelly to Nemaha Wind Farm GEN-2007-015) CB1280-BUS OPEN 646280 S1280 5 161 TO 640140 COOPER 5 161 1 OPEN 646280 S1280 5 161 TO 640234 HUMBOLTS 161 1 OPEN 646280 S1280 5 161 TO 646263 S1263 5 161 1	C	12G

Monitored Element	Rating MVA	Pre-Project Loading (%)	Post-Project Loading (%)	DF (%)	Contingency	Type	Case
532913 KELLY 5 161 532920 TECHILL5 161 1	161	119.6	127	96.2	Prior: (S1399 to Humboldt) OPEN 532913 KELLY 5 161 TO 533217 KELLY 3 115 TO 532942 KELLY 1 13.8 CKT 1	B	12S
533332 KNOB HL3 115 560141 G09-40T 115 1	92	110.5	115.2	38.1	Prior: (S1399 to Humboldt) OPEN 532913 KELLY 5 161 TO 532920 TECHILL5 161 1	B	12S
635034 CLRNDA 5 161 560001 NODAWAYCO 161 1	153	271.3	271.6	4.8	Prior: (S1399 to Humboldt) OPEN 541251 MARYVLE5 161 TO 560001 NODAWAYCO 161 1	B	12S
640235 HUMBOLT7 115 640361 STEINER7 115 1	120	155.4	166	93.3	Prior: (Kelly to Nemaha Wind Farm) CBHUM-80&T4 OPEN 640234 HUMBOLT5 161 TO 647975 S975 8 69 TO 648275 S975T4 9 13.8 1 OPEN 640234 HUMBOLT5 161 TO 646280 S1280 5 161 1	C	12S
640234 HUMBOLT5 161 3WINDTR S975 T4 WND	67.2	162.3	168	37.1	Prior: (Kelly to Nemaha Wind Farm GEN-2007-015) CB1280-BUS OPEN 646280 S1280 5 161 TO 640140 COOPER 5 161 1 OPEN 646280 S1280 5 161 TO 640234 HUMBOLT5 161 1 OPEN 646280 S1280 5 161 TO 646263 S1263 5 161 1	C	12S
560332 G10-47T 115 640208 HARBINE7 115 1	99	129.5	130.3	6.7	Prior: (Kelly to Nemaha Wind Farm GEN-2007-015) CBHUM-80&T4 OPEN 640234 HUMBOLT5 161 TO 647975 S975 8 69 TO 648275 S975T4 9 13.8 1 OPEN 640234 HUMBOLT5 161 TO 646280 S1280 5 161 1	C	12S
646263 S1263 5 161 3WINDTR S1263 T1 WND	106	108.1	108.5	3.8	Prior: (Kelly to Nemaha Wind Farm GEN-2007-015) OPEN 640234 HUMBOLT5 161 TO 647975 S975 8 69 TO 648275 S975T4 9 13.8 1	B	12S

4. Short Circuit Study

4.1 Computer Programs

Short-Circuit analyses was performed using PSS®E version 30.3.2.

4.2 Methodology

Analysis was performed using PSS®E activity ANSI, which calculates fault currents according to the ANSI/IEEE Standard C37.5-1979. The following assumptions were made during execution of activity ANSI:

- Maximum operating voltage is 1.05 pu
- Transformer impedance correction was not applied to zero-sequence transformer impedances
- For branches and machines with a zero value of resistance in the positive or zero sequence network, the zero value was replaced with a non-zero resistance equal to the positive or zero sequence reactance divided by a scaling factor. A scaling factor of 83 for branches and a factor of 252 for machines were used.
- The fault-current multiplying factors include the effects of dc decrement only
- Reactance is used to determine short-circuit current magnitudes (E/X calculation)
- Contact parting times are the minimum parting times shown in Figure 10 of IEEE Standard C37.010-1999, i.e., three-cycle contact parting time for 5-cycle breaker, two-cycle contact parting time for 3-cycle breaker, and 1.5-cycle contact parting time for 2-cycle breaker.

For both three-phase and single-line-to-ground faults, activity ANSI calculates the symmetrical fault current, the X/R ratio as specified in ANSI/IEEE Standard C37.5-1979 and IEEE Standard C37.010-1999, and the fault-current multiplying factor from ANSI/IEEE Standard C37.5-1979 for determining the adequacy of the interrupting capability of breakers rated on a total current basis. Fault-current multiplying factors for determining the adequacy of the interrupting capability of breakers rated on a symmetrical current basis are not calculated by the activity and were determined external to PSS®E from IEEE Standard C37.010-1999.

Results were produced for a transmission-system topology of all branches in service for all buses within the OPPD area and all buses seven or fewer buses away from the GEN-2010-041 Point of Interconnection. Results were distributed to companies in whose area in the models there was at least one bus with an increase caused by the GEN-2010-041 project of more than 2 amps in the maximum between three-phase and single-line-to-ground faults of the product of the symmetrical fault current and either of the two types of fault-current multiplying factors described above. These companies and OPPD then each performed an evaluation to determine whether any of their circuit breakers would not have adequate interrupting capability based on the results for a transmission-system

topology of all branches in service. For any such breakers, more-detailed analysis would then be performed to determine the actual interrupting duty of those breakers based on the configuration of the substation in which they are located.

For the OPPD system, only circuit breakers at a nominal voltage level of 69 kV or higher were evaluated. Adequacy of the interrupting capability of each OPPD circuit breaker was determined by multiplying the symmetrical fault current seen by the breaker by the appropriate fault-current multiplying factor and comparing the result with the breaker's interrupting rating reduced for reclosing service as appropriate.

4.3 Short-Circuit Model

OPPD started with a short circuit model that consisted of the “Study Case” short circuit model used in the short circuit analysis for the existing Flat Water wind farm with various updates applied. From this starting model OPPD developed two cases: a benchmark case without the GEN-2010-041 wind farm project and a change case which included the GEN-2010-041 wind farm project. The only difference between the benchmark case and the change case was the inclusion of the GEN-2010-041 wind farm project in the change case.

Benchmark case short circuit model:

- *04sc_final_m3_SPPv303_gen_on_nc2_May_19_updth_GI4_Cooper_jpmx_FWbase_r1.sav*
 - Model Updates:
 - Updated Flat Water bus numbers and names
 - Updated Flat Water 161/34.5kV step-up transformer MVA base and positive sequence impedance.
 - Updated existing Flat Water MBASE
 - Updated existing Flat Water turbine combined step-up transformer positive and zero sequence impedance.

Change case short circuit model – (Contains Flat Water 10.5 MW Uprate):

- *04sc_final_m3_SPPv303_gen_on_nc2_May_19_updth_GI4_Cooper_jpmx_FW10.5MWuprate_r1.sav*
 - Model Updates:
 - Includes updates from the benchmark case short circuit model
 - Added GEN-2010-041

The request for interconnection indicated that the GEN-2010-041 project would consist of the addition of seven GE 1.5-MW wind turbines. The developer of the GEN-2010-041 project subsequently indicated to OPPD that the type of wind turbines that would be added would be GE 1.85-MW wind turbines. Accordingly, the model parameters that were used in this study for the GEN-2010-041 project represent the addition of seven GE

1.85-MW wind turbines.

A one-line diagram showing how the GEN-2010-041 project was modeled is shown in Figure 4-1. The model parameters used in this study for the existing Flat Water wind farm and the GEN-2010-041 project are documented in Section B.2 of Appendix B.

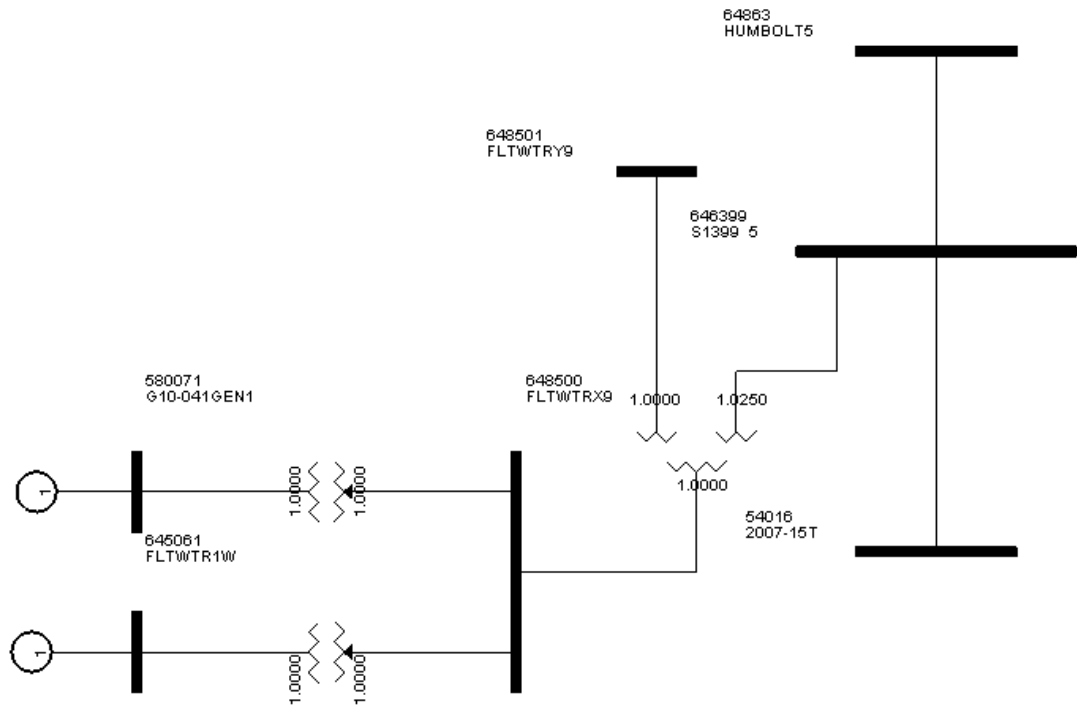

Figure 4-1: GEN-2010-041 - One-Line Diagram

4.5 Results

Interrupting devices were checked at substations seven or fewer buses away from the GEN-2010-041 Point of Interconnection (S1399 161 kV).

Results from the benchmark case and the change case for the product of symmetrical fault current and the appropriate multiplying factor from the ANSI/IEEE standards for a transmission-system topology of all branches in service are shown in Appendix D. Results are shown for breakers with Rated Interrupting Times of 2, 3 and 5 cycles for all buses seven or fewer buses away from the Point of Interconnection of the GEN-2010-041 project. For the OPPD area, results are also shown for buses more than seven buses away from the Point of Interconnection of the GEN-2010-041 project. The currents in the tables of Appendix D are the higher of the currents for either three-phase or single-line-to-ground faults.

The NPPD and Westar areas are the only non-OPPD areas having at least one bus with a value for “Fault Current Increase” in Appendix D of more than 2 amps. These companies and OPPD each performed an evaluation to determine whether any of their circuit breakers would not have adequate interrupting capability based on the results for a transmission-system topology of all branches in service. The review by OPPD, NPPD and Westar of the results for a transmission-system topology of all branches in service uncovered no breakers whose interrupting capability would potentially be inadequate.

5. Mitigation Plans

The short circuit analysis did not identify that any equipment upgrades were required; therefore, there are not any required short circuit mitigation projects. The steady-state contingency analysis did not identify any ERIS constraints; therefore, there are not any required ERIS mitigation projects. There were some NRIS constraints and prior outage constraints. Potential mitigation plans for these NRIS and prior outage constraints are provided for informational purposes but are not required to accommodate the customer's ERIS request. Mitigation plans for some of these constraints have been identified and are presented in this section.

5.1. NRIS and Prior Outage Related Constraints

The steady-state contingency analysis identified five (5) NRIS thermal constraints for single event contingency conditions and eighteen (18) thermal constraints for prior outage contingency conditions. Mitigation plans for these constraints have been identified and are presented below:

5.1.1. Single-Event Contingency Interconnection Constraints

- Humboldt-S975 161-69 kV transformer
- BPS Sub - Clatona 115 kV line
- G10-47T – Harbine 115kV line
- S1263 T1 161-69kV transformer
- Clarinda – Nodaway 161kV line

The OPPD Humboldt-S975 161/69 kV T4 transformer had a worst case post-contingency loading of 124.1% of the 67.2 MVA rating in the case with the GEN-2010-041 wind project. Additional 161/69 kV transformer capacity could be added to mitigate the overload of the OPPD Humboldt-S975 161/69 kV T4 transformer. Single event-contingency analysis was performed with the addition of a second 67.2 MVA transformer. The analysis demonstrated that this facility upgrade mitigated all post-contingent loading issues on the Humboldt-S975 161/69 kV transformer and also demonstrated that no additional facility loading issues were created. Adding additional 161/69 kV transformer capacity at Humboldt will mitigate the GEN-2010-041 wind project's impacts on this transformer loading.

The BPS Sub - Clatona 115 kV line had a worst case post-contingency loading of 103.2% of the 137 MVA rating in the case with GEN-2010-041 wind project. Loading of this facility is significantly impacted by the max generation output at NPPD's Beatrice Power Station and prior queued wind facilities GEN-2010-047 and GEN-2007-015. Westar wind facility GEN-2007-015 is currently on suspension; the outcome of this facility may affect mitigation plans for this facility. Mitigation might involve line re-conductor

projects or line rebuilds or attentive generation dispatch.

The G10-47T – Harbine 115kV line had a worst case post-contingency loading of 103.2% of the 99 MVA rating in the case with GEN-2010-041 wind project. Loading of this facility is significantly impacted by the max generation output at NPPD’s Beatrice Power Station and prior queued wind facilities GEN-2010-047 and GEN-2007-015. Westar wind facility GEN-2007-015 is currently on suspension; the outcome of this facility may affect mitigation plans for this facility. Mitigation might involve line re-conductor projects or line rebuilds or attentive generation dispatch.

The S1263 T1 161-69kV transformer had a worst case post-contingency loading of 105.6% of the 106 MVA rating in the case with the GEN-2010-041 wind facility. Additional 161/69 kV transformer capacity at Humboldt substation could be added to mitigate the overload of the S1263 T1 161-69kV transformer. Single event-contingency analysis was performed with the addition of a second 67.2 MVA transformer. The analysis demonstrated that this facility upgrade mitigated all post-contingent loading issues on the S1263 T1 161-69kV transformer and also demonstrated that no additional facility loading issues were created. Adding additional 161/69 kV transformer capacity at Humboldt will mitigate the GEN-2010-041 wind project’s impacts on this transformer loading.

The Clarinda – Nodaway 161kV line had a worst case post-contingency loading of 185.7% of the 167 MVA rating in the case with the GEN-2010-041 wind project. Further analysis on this line loading revealed that there is a worst case post-contingent overload of 255.4% in the Benchmark case without the GEN-2010-041 wind project. This worst case post-contingency loading of 255.4% in the Benchmark case is for a different single event contingency (loss of Nodaway-Maryville 161 kV). Loading of this facility is significantly impacted by the max generation output from three prior queued MIPU wind facilities which are on suspension: GEN-2006-014, GEN-2006-017 and GEN-2007-017. These results have shown that the Clarinda – Nodaway 161kV post-contingent loading issue is a pre-existing issue regardless of the GEN-2010-041 wind facility interconnection. Subsequent to MIPU determining mitigation plans for this pre-existing loading issue, the Customer could work with MIPU to determine if any mitigation is required of the GEN-2010-041 wind project.

5.1.2. Prior Outage Contingency Interconnection Constraints

- Kelly 161-115-13.8 kV transformer
- Kelly-Tecumseh Hill 161 kV line
- Humboldt T2 161-115 kV transformer
- Humboldt – Steiner 115kV line
- Beatrice - Steiner 115kV line
- Kelly-King Hill 115 kV
- Circleville – King Hill 115kV
- Auburn Tap-S975 69 kV line

- Humboldt-S975 161-69 kV transformer
- Knob Hill – G09-40T 115kV
- BPS Sub7 - Clatona 115 kV line
- Midian 161-138 kV transformer
- Clatona – Sheldon 115 kV line
- WM Bros – Midian 161kV line
- Tecumseh hill – WM Bros 161kV line
- G10-47T – Harbine 115kV line
- Clarinda – Nodaway 161kV line
- S1263 T1 161-69kV transformer

All of these impacted facilities were significantly affected by the GEN-2010-041 wind project during prior outage conditions. In real-time operations when the problematic prior outage conditions listed in this report occur, the GEN-2010-041 wind facility could be subject to output restrictions by an amount sufficient to mitigate its impacts on the impacted facilities listed above.

6. Power Factor Correction

The SPP System Impact Study completed in July 2011 (DISIS-2010-002-1) established the final power factor requirement at the point of interconnection (S1399) for GEN-2010-041 to be 0.965 leading/lagging.

The existing 60 MW wind farm and 10.5 MW addition both share the same 161/34.5 kV generator step-up transformer (GSU) which is rated for 75 MVA. It is assumed that the 60 MW and 10.5 MW wind turbines have a 0.9 leading/lagging power factor capability. For this assumption the maximum MVA output capability of the combined wind farm is 78.3 MVA. If approximately 1.8 MVA is attributed to losses between the turbines and the 34.5 kV bus, then there is a potential to overload the existing 161/34.5 kV GSU by 102% (76.5 MVA).

For conditions when the total wind farm generation output is at its maximum MVA generating capability and is producing reactive power to support voltage at S1399, there is a potential to overload the 161/34.5 kV GSU. This was observed in OPPD sensitivity studies where the voltage schedule was adjusted for GEN-2010-041. This issue can be mitigated by reducing the voltage schedule at S1399.

7. Metering and Communication

The wind farm developer for GEN-2010-041 will be required to adhere to OPPD metering and communication requirements in order to separate this 10.5 MW addition from OPPD's existing 60 MW portion of the combined 70.5 MW wind generating facility. The details of the metering and communication requirements will be addressed in the generation interconnection agreement (GIA) for GEN-2010-041.

8. Conclusion

This report presents the results of steady-state contingency analysis and short-circuit analysis performed to evaluate the interconnection impacts of the GEN-2010-041 wind facility in accordance with NERC TPL-001, 002 & 003 Standards using SPP ERIS and NRIS impact criteria. There are not any constraints or associated mitigation requirements to accommodate the customer's ERIS request. There were some constraints identified for the NRIS evaluation and for prior outage conditions. Potential mitigation plans for these NRIS and prior outage constraints were identified and provided for information. The wind farm developer for GEN-2010-041 will be required to adhere to OPPD metering and communication requirements in order to separate the 10.5 MW addition from OPPD's existing 60 MW portion of the combined 70.5 MW wind generating facility. Metering and communication requirements will be outlined in the GIA for GEN-2010-041.

Appendix A. Model Development for Steady-State Analysis

A.1 Generation Projects

The following projects were added to the MDWG 2011 series models and dispatched as shown in Table A-1:

Table A-1: Generation Projects

Request	Amount (MW)	Area	Sink	Proposed Point of Interconnection (POI)
ASGI-2010-001	400	AECI	SPP	Tap Cooper – Fairport 345kV
ASGI-2010-005	99	AECI	SPP	Lathrop 161kV
ASGI-2010-009	201	AECI	SPP	Osborn 161kV
GEN-2006-014	300	MIPU	SPP	Tap Maryville – Clarinda 161kV & Tie to Midway 161kV
GEN-2006-017	300	MIPU	SPP	Tap Maryville – Clarinda 161kV & Tie to Midway 161kV
GEN-2007-015	135	WERE	SPP	Tap Humboldt – Kelly 161kV
GEN-2007-017	100.5	MIPU	SPP	Tap Maryville – Clarinda 161kV & Tie to Midway 161kV
GEN-2007-053	110	MIPU	SPP	Tap Maryville – Clarinda 161kV & Tie to Midway 161kV
GEN-2010-041	10.5	OPPD	OPPD	S1399 161kV
GEN-2010-047	72	NPPD	SPP	Tap Beatrice – Harbine 115kV
GEN-2009-040	73.8	WERE	SPP	Tap Smittyville – Knob Hill 115kV
J133	100.5	MEC	SPP	Cooper – Atchison 345 kV
R26	400	MEC	SPP	256 MW uprate of existing Atchison wind farm

Appendix B. Modeling Data for GEN-2010-041

B.1 Power Flow Model Data

DATA FOR BUS 580070 [G10-041 34.500] RESIDING IN AREA 645, ZONE 1, OWNER 1:

```
CODE PLOAD QLOAD I - L O A D Y - L O A D G-SHUNT B-SHUNT
1 0.0 0.0 0.0 0.0 0.0 0.0 0.0 0.0
```

X----- TO BUS -----X

```
BUS# X-- NAME --X BASKV CKT LINE R LINE X CHARGING ST MET RATE-A RATE-B RATE-C
648500 FLTWTRX9 34.500 1 0.03830 0.05414 0.00310 1 T 0.0 0.0 0.0
```

X----- TO BUS -----X

```
BUS# X-- NAME --X BASKV CKT XFRMER S W M C C SPECIFIED
580071 G10-041GEN1 0.6900 1 --X T 1 T Z M R 1-2 X 1-2 SBAS1-2
1 F F 2 1 0.00760 0.05700 12.2
```

X----- TO BUS -----X

```
BUS# X-- NAME --X BASKV CKT W WINDV1 NOMV1 ANGLE WINDV2 NOMV2 RATEA RATEB RATEC
580071 G10-041GEN1 0.6900 1 1 1.00000 0.0000 0.0 1.00000 0.0000 0.0 0.0 0.0
```

X----- TO BUS -----X

```
BUS# X-- NAME --X BASKV CKT W CN RMAX RMIN VMAX VMIN NTPS
580071 G10-041GEN1 0.6900 1 F 1 0 1.10000 0.90000 1.10000 0.90000 5
```

DATA FOR BUS 580071 [G10-041GEN1 0.6900] RESIDING IN AREA 645, ZONE 1, OWNER 1:

```
CODE PLOAD QLOAD I - L O A D Y - L O A D G-SHUNT B-SHUNT
2 0.0 0.0 0.0 0.0 0.0 0.0 0.0 0.0
```

```
PLNT PGEN QGEN QMAX QMIN VSCHED PCT Q
10.5 -2.1 5.8 -5.8 1.02000 100.00
```

```
ID ST PGEN QGEN QMAX QMIN MBASE Z S O R C E X T R A N GENTAP PMAX PMIN
1 1 10.5 -2.1 5.8 -5.8 11.7 0.0000 0.8000 0.0000 0.0000 1.0000 10.5 1.0
```

X----- TO BUS -----X

```
BUS# X-- NAME --X BASKV CKT XFRMER S W M C C SPECIFIED
580070 G10-041 34.500 1 --X T 1 T Z M R 1-2 X 1-2 SBAS1-2
1 T T 2 1 0.00760 0.05700 12.2
```

X----- TO BUS -----X

```
BUS# X-- NAME --X BASKV CKT W WINDV1 NOMV1 ANGLE WINDV2 NOMV2 RATEA RATEB RATEC
580070 G10-041 34.500 1 1 1.00000 0.0000 0.0 1.00000 0.0000 0.0 0.0 0.0
```

X----- TO BUS -----X

```
BUS# X-- NAME --X BASKV CKT W CN RMAX RMIN VMAX VMIN NTPS
580070 G10-041 34.500 1 T 1 0 1.10000 0.90000 1.10000 0.90000 5
```

Table B-1: GEN-2010-41 Wind Farm Dispatch in 2012 Summer Case

Unit	Benchmark Case (MW)	Study Case (MW)	Change (MW)
SARPY 3G	66.6	56.1	10.5

Table B-2: GEN-2010-41 Wind Farm Dispatch in 2012 Spring Case

Unit	Benchmark Case (MW)	Study Case (MW)	Change (MW)
NEBCTY1G	581.3	570.8	10.5

Table B-3: GEN-2010-41 Wind Farm Dispatch in 2012 Winter Case

Unit	Benchmark Case (MW)	Study Case (MW)	Change (MW)
N OMA 5G	113.2	102.7	10.5

Table B-4: GEN-2010-41 Wind Farm Dispatch in 2017 Summer Case

Unit	Benchmark Case (MW)	Study Case (MW)	Change (MW)
CASS 1G	157.9	147.4	10.5

Table B-5: GEN-2010-41 Wind Farm Dispatch in 2017 Winter Case

Unit	Benchmark Case (MW)	Study Case (MW)	Change (MW)
N OMA 4G	58.7	48.2	10.5

B.2 Short Circuit Wind Farm Parameters

PSS® Activity EXAM

DATA FOR BUS 580071 [G10-041GEN1 0.6900] RESIDING IN AREA 645, ZONE 1, OWNER 1:

CODE	P	Q	-	L	O	A	D	I	-	L	O	A	D	Y	-	L	O	A	D	G-SHUNT	B-SHUNT	VOLTAGE	ANGLE
2	0.0	0.0		0.0	0.0	0.0	0.0	0.0	0.0	0.0	0.0	0.0	0.0	0.0	0.0	0.0	0.0	0.0	0.0	0.0	1.00300	1.00	

PLNT	PGEN	QGEN	QMAX	QMIN	VSCHED	PCT	Q	BUS#	X--	NAME	--X	BASKV	VOLTAGE
10.5	0.0	5.1	-5.1	1.02000	100.00								

ID	ST	PGEN	QGEN	QMAX	QMIN	MBASE	Z	S	O	R	C	E	X	T	R	A	N	GENTAP	P	M	A	X	P	M	I	N	OWN1	FRAC1	OWN2	FRAC2	OWN3	FRAC3	OWN4	FRAC4	W	M	O	D	W	P	F		
1	1	10.5	0.0	5.1	-5.1	14.6	0.0000	0.8000	0.0000	0.0000	0.0000	1.0000	10.5	1.0	1	1.000																											

(The exact value used for MBASE was 14.646.)

X-----	TO	BUS	-----X	XFRMER	S	W	M	C	C	SPECIFIED	MAGNETIZING	Y	TBL	CORRECTED											
BUS#	X--	NAME	--X	BASKV	CKT	X--	NAME	--X	T	1	T	Z	M	R	1-2	X	1-2	SBAS1-2	MAG1	MAG2	TBL	R	1-2	X	1-2
648500	FLTWTRX9	34.500	1		1	T	T	2	1	0.04089	0.40887	100.0	0.00000	0.00000	0										

X-----	TO	BUS	-----X	C	W	WINDV1	NOMV1	ANGLE	WINDV2	NOMV2	RATEA	RATEB	RATEC	OWN1	FRAC1	OWN2	FRAC2	OWN3	FRAC3	OWN4	FRAC4	
BUS#	X--	NAME	--X	BASKV	CKT	W	WINDV1	NOMV1	ANGLE	WINDV2	NOMV2	RATEA	RATEB	RATEC	OWN1	FRAC1	OWN2	FRAC2	OWN3	FRAC3	OWN4	FRAC4
648500	FLTWTRX9	34.500	1	1	1.00000	0.0000	0.0	1.00000	0.0000	0.0	0.0	0.0	0.0	0.0	645	1.000						

X-----	TO	BUS	-----X	W	C	R	MAX	R	MIN	V	MAX	V	MIN	N	T	P	S	X----	CONTROLLED	BUS	-----X	CONECXN	ANGLE	CR	CX			
BUS#	X--	NAME	--X	BASKV	CKT	1	W	CN	R	MAX	R	MIN	V	MAX	V	MIN	N	T	P	S	BUS#	X--	NAME	--X	BASKV	ANGLE	CR	CX
648500	FLTWTRX9	34.500	1	T	1	0	1.10000	0.90000	1.10000	0.90000	5																	

DATA FOR BUS 645061 [FLTWTR1W 0.5750] RESIDING IN AREA 645, ZONE 691, OWNER 645:

CODE	P	Q	-	L	O	A	D	I	-	L	O	A	D	Y	-	L	O	A	D	G-SHUNT	B-SHUNT	VOLTAGE	ANGLE
2	0.0	0.0		0.0	0.0	0.0	0.0	0.0	0.0	0.0	0.0	0.0	0.0	0.0	0.0	0.0	0.0	0.0	0.0	0.0	1.00000	0.00	

PLNT	PGEN	QGEN	QMAX	QMIN	VSCHED	PCT	Q	BUS#	X--	NAME	--X	BASKV	VOLTAGE
60.0	0.0	29.0	-29.0	1.02000	100.00								

ID	ST	PGEN	QGEN	QMAX	QMIN	MBASE	Z	S	O	R	C	E	X	T	R	A	N	GENTAP	P	M	A	X	P	M	I	N	OWN1	FRAC1	OWN2	FRAC2	OWN3	FRAC3	OWN4	FRAC4	W	M	O	D	W	P	F		
1	1	60.0	0.0	29.0	-29.0	68.7	0.0000	0.8000	0.0000	0.0000	0.0000	1.0000	60.0	2.8	645	1.000																											

(The exact value used for MBASE was 68.667.)

X-----	TO	BUS	-----X	XFRMER	S	W	M	C	C	SPECIFIED	MAGNETIZING	Y	TBL	CORRECTED											
BUS#	X--	NAME	--X	BASKV	CKT	X--	NAME	--X	T	1	T	Z	M	R	1-2	X	1-2	SBAS1-2	MAG1	MAG2	TBL	R	1-2	X	1-2
648500	FLTWTRX9	34.500	1		1	T	T	1	1	0.01086	0.08142	100.0	0.00000	0.00000	0										

(The exact values used for R 1-2 and X 1-2 were 0.010856 and 0.081422, respectively.)

X----- TO BUS -----X C
 BUS# X-- NAME --X BASKV CKT W WINDV1 NOMV1 ANGLE WINDV2 NOMV2 RATEA RATEB RATEC OWN1 FRAC1 OWN2 FRAC2 OWN3 FRAC3 OWN4 FRAC4
 648500 FLTWTXR9 34.500 1 1 1.00000 0.0000 0.0 1.00000 0.0000 70.0 70.0 0.0 1 1.000

X----- TO BUS -----X W C X---- CONTROLLED BUS ----X CONECXN
 BUS# X-- NAME --X BASKV CKT 1 W CN RMAX RMIN VMAX VMIN NTPS BUS# X-- NAME --X BASKV ANGLE CR CX
 648500 FLTWTXR9 34.500 1 T 1 0 1.10000 0.90000 1.10000 0.90000 33 0.000

DATA FOR BUS 646399 [S1399 5 161.00] RESIDING IN AREA 645, ZONE 691, OWNER 645:

CODE P Q - L O A D I - L O A D Y - L O A D G-SHUNT B-SHUNT VOLTAGE ANGLE
 1 0.0 0.0 0.0 0.0 0.0 0.0 0.0 0.0 0.0 1.02680 -28.25

X----- TO BUS -----X
 BUS# X-- NAME --X BASKV CKT LINE R LINE X CHARGING ST MET RATE-A RATE-B RATE-C LENGTH ZI OWN1 FRAC1 OWN2 FRAC2 OWN3 FRAC3 OWN4 FRAC4
 54016 2007-15T 161.00 1 0.00097 0.00910 0.00461 1 T 298.0 298.0 298.0 3.1 1 1.000
 64863 HUMBOLT5 161.00 1 0.00457 0.03469 0.01778 1 F 298.0 298.0 298.0 12.0 1 1.000

X- XFRMER -X X---- WINDING 1 BUS ----X X---- WINDING 2 BUS ----X X---- WINDING 3 BUS ----X S C C C
 X-- NAME --X BUS# X-- NAME --X BASKV BUS# X-- NAME --X BASKV BUS# X-- NAME --X BASKV CKT T W Z M OWN1 FRAC1 OWN2 FRAC2 OWN3 FRAC3 OWN4 FRAC4
 WIND-TX 646399 S1399 5 161.00 648500 FLTWTXR9 34.500 648501 FLTWTTRY9 13.800 1 1 1 2 1 645 1.000

X- XFRMER -X S C X----- SPECIFIED NOMINAL MEASURED IMPEDANCES AND MVA BASES -----X X-ACTUAL IMPEDANCES FROM IMPEDANCE CORRECTION TABLE-X
 X-- NAME --X T Z R 1-2 X 1-2 SBAS1-2 R 2-3 X 2-3 SBAS2-3 R 3-1 X 3-1 SBAS3-1 R 1-2 X 1-2 R 2-3 X 2-3 R 3-1 X 3-1
 WIND-TX 1 2 0.00601 0.20838 100.0 0.00601 0.20838 100.0 0.00601 0.20838 100.0

X- XFRMER -X X----- WINDING BUS -----X S C MAGNETIZING Y SYSTEM BASE NOM. TBL CORRECTED STAR POINT BUS
 X-- NAME --X BUS# X-- NAME --X BASKV T M MAG1 MAG2 R WNDNG X WNDNG RATEA RATEB RATEC TBL R WNDNG X WNDNG VOLTAGE ANGLE
 WIND-TX 646399 S1399 5 161.00* 1 1 0.00000 0.00000 0.00300 0.10419 75.0 75.0 75.0 0 1.00000 0.0
 648500 FLTWTXR9 34.500 1 0.00300 0.10419 75.0 75.0 75.0 0
 648501 FLTWTTRY9 13.800* 1 0.00300 0.10419 75.0 75.0 75.0 0

X- XFRMER -X X----- WINDING BUS -----X C X---- CONTROLLED BUS ----X CNXTN
 X-- NAME --X BUS# X-- NAME --X BASKV W CN WIND V NOM V ANGLE RMAX RMIN VMAX VMIN NTPS BUS# X-- NAME --X BASKV ANGLE CR CX
 WIND-TX 646399 S1399 5 161.00 1 0 1.02500 0.0000 0.0 1.05000 0.95000 1.10000 0.90000 5 0.0
 648500 FLTWTXR9 34.500 0 1.00000 0.0000 0.0 1.05000 0.95000 1.10000 0.90000 5 0.0
 648501 FLTWTTRY9 13.800 0 1.00000 0.0000 0.0 1.05000 0.95000 1.10000 0.90000 5 0.0

DATA FOR BUS 648500 [FLTWTXR9 34.500] RESIDING IN AREA 645, ZONE 691, OWNER 645:

CODE P Q - L O A D I - L O A D Y - L O A D G-SHUNT B-SHUNT VOLTAGE ANGLE
 1 0.0 0.0 0.0 0.0 0.0 0.0 0.0 0.0 0.0 1.00000 0.00

X----- TO BUS -----X XFRMER S W M C C SPECIFIED MAGNETIZING Y TBL CORRECTED
 BUS# X-- NAME --X BASKV CKT X-- NAME --X T 1 T Z M R 1-2 X 1-2 SBAS1-2 MAG1 MAG2 TBL R 1-2 X 1-2
 580071 G10-041GEN1 0.6900 1 1 F F 2 1 0.04089 0.40887 100.0 0.00000 0.00000 0
 645061 FLTWTTR1W 0.5750 1 1 F F 1 1 0.01086 0.08142 100.0 0.00000 0.00000 0
 (The exact values used for R 1-2 and X 1-2 of the transformer to Bus 645061 were 0.010856 and 0.081422, respectively.)

X----- TO BUS -----X C
 BUS# X-- NAME --X

BASKV CKT W WINDV1

NOMV1 ANGLE WINDV2 NOMV2 RATEA RATEB RATEC OWN1 FRAC1 OWN2 FRAC2 OWN3 FRAC3 OWN4 FRAC4
 580071 G10-041GEN1 0.6900 1 1 1.00000 0.0000 0.0 1.00000 0.0000 0.0 0.0 0.0 645 1.000
 645061 FLTWTWR1W 0.5750 1 1 1.00000 0.0000 0.0 1.00000 0.0000 70.0 70.0 0.0 1 1.000

X----- TO BUS -----X W C X---- CONTROLLED BUS ----X CONECXN
 BUS# X-- NAME --X BASKV CKT 1 W CN RMAX RMIN VMAX VMIN NTPS BUS# X-- NAME --X BASKV ANGLE CR CX
 580071 G10-041GEN1 0.6900 1 F 1 0 1.10000 0.90000 1.10000 0.90000 5 0.000
 645061 FLTWTWR1W 0.5750 1 F 1 0 1.10000 0.90000 1.10000 0.90000 33 0.000

X- XFRMER -X X---- WINDING 1 BUS ----X X---- WINDING 2 BUS ----X X---- WINDING 3 BUS ----X S C C C
 X-- NAME --X BUS# X-- NAME --X BASKV BUS# X-- NAME --X BASKV BUS# X-- NAME --X BASKV CKT T W Z M OWN1 FRAC1 OWN2 FRAC2 OWN3 FRAC3 OWN4 FRAC4
 WIND-TX 646399 S1399 5 161.00 648500 FLTWTWRX9 34.500 648501 FLTWTTRY9 13.800 1 1 1 2 1 645 1.000

X- XFRMER -X S C X----- SPECIFIED NOMINAL MEASURED IMPEDANCES AND MVA BASES -----X X-ACTUAL IMPEDANCES FROM IMPEDANCE CORRECTION TABLE-X
 X-- NAME --X T Z R 1-2 X 1-2 SBAS1-2 R 2-3 X 2-3 SBAS2-3 R 3-1 X 3-1 SBAS3-1 R 1-2 X 1-2 R 2-3 X 2-3 R 3-1 X 3-1
 WIND-TX 1 2 0.00601 0.20838 100.0 0.00601 0.20838 100.0 0.00601 0.20838 100.0 0.00601 0.20838 100.0

X- XFRMER -X X----- WINDING BUS -----X S C MAGNETIZING Y SYSTEM BASE NOM. TBL CORRECTED STAR POINT BUS
 X-- NAME --X BUS# X-- NAME --X BASKV T M MAG1 MAG2 R WNDNG X WNDNG RATEA RATEB RATEC TBL R WNDNG X WNDNG VOLTAGE ANGLE
 WIND-TX 646399 S1399 5 161.00* 1 1 0.00000 0.00000 0.00300 0.10419 75.0 75.0 75.0 0 1.00000 0.0
 648500 FLTWTWRX9 34.500 1 0.00300 0.10419 75.0 75.0 75.0 0
 648501 FLTWTTRY9 13.800* 1 0.00300 0.10419 75.0 75.0 75.0 0

X- XFRMER -X X----- WINDING BUS -----X C X---- CONTROLLED BUS ----X CNXTN
 X-- NAME --X BUS# X-- NAME --X BASKV W CN WIND V NOM V ANGLE RMAX RMIN VMAX VMIN NTPS BUS# X-- NAME --X BASKV ANGLE CR CX
 WIND-TX 646399 S1399 5 161.00 1 0 1.02500 0.0000 0.0 1.05000 0.95000 1.10000 0.90000 5 0.0
 648500 FLTWTWRX9 34.500 0 1.00000 0.0000 0.0 1.05000 0.95000 1.10000 0.90000 5 0.0
 648501 FLTWTTRY9 13.800 0 1.00000 0.0000 0.0 1.05000 0.95000 1.10000 0.90000 5 0.0

DATA FOR BUS 648501 [FLTWTTRY9 13.800] RESIDING IN AREA 645, ZONE 691, OWNER 645:

CODE P Q - L O A D I - L O A D Y - L O A D G-SHUNT B-SHUNT VOLTAGE ANGLE
 1 0.0 0.0 0.0 0.0 0.0 0.0 0.0 0.0 1.00000 0.00

X- XFRMER -X X---- WINDING 1 BUS ----X X---- WINDING 2 BUS ----X X---- WINDING 3 BUS ----X S C C C
 X-- NAME --X BUS# X-- NAME --X BASKV BUS# X-- NAME --X BASKV BUS# X-- NAME --X BASKV CKT T W Z M OWN1 FRAC1 OWN2 FRAC2 OWN3 FRAC3 OWN4 FRAC4
 WIND-TX 646399 S1399 5 161.00 648500 FLTWTWRX9 34.500 648501 FLTWTTRY9 13.800 1 1 1 2 1 645 1.000

X- XFRMER -X S C X----- SPECIFIED NOMINAL MEASURED IMPEDANCES AND MVA BASES -----X X-ACTUAL IMPEDANCES FROM IMPEDANCE CORRECTION TABLE-X
 X-- NAME --X T Z R 1-2 X 1-2 SBAS1-2 R 2-3 X 2-3 SBAS2-3 R 3-1 X 3-1 SBAS3-1 R 1-2 X 1-2 R 2-3 X 2-3 R 3-1 X 3-1
 WIND-TX 1 2 0.00601 0.20838 100.0 0.00601 0.20838 100.0 0.00601 0.20838 100.0

X- XFRMER -X X----- WINDING BUS -----X S C MAGNETIZING Y SYSTEM BASE NOM. TBL CORRECTED STAR POINT BUS
 X-- NAME --X BUS# X-- NAME --X BASKV T M MAG1 MAG2 R WNDNG X WNDNG RATEA RATEB RATEC TBL R WNDNG X WNDNG VOLTAGE ANGLE
 WIND-TX 646399 S1399 5 161.00* 1 1 0.00000 0.00000 0.00300 0.10419 75.0 75.0 75.0 0 1.00000 0.0
 648500 FLTWTWRX9 34.500 1 0.00300 0.10419 75.0 75.0 75.0 0
 648501 FLTWTTRY9 13.800* 1 0.00300 0.10419 75.0 75.0 75.0 0

X- XFRMER -X X----- WINDING BUS -----X C X---- CONTROLLED BUS ----X CNXTN
 X-- NAME --X BUS# X-- NAME --X BASKV W CN WIND V NOM V ANGLE RMAX RMIN VMAX VMIN NTPS BUS# X-- NAME --X BASKV ANGLE CR CX
 WIND-TX 646399 S1399 5 161.00 1 0 1.02500 0.0000 0.0 1.05000 0.95000 1.10000 0.90000 5 0.0
 648500 FLTWTWRX9 34.500 0 1.00000 0.0000 0.0 1.05000 0.95000 1.10000 0.90000 5 0.0
 648501 FLTWTTRY9 13.800 0 1.00000 0.0000 0.0 1.05000 0.95000 1.10000 0.90000 5 0.0

1.00000 0.0000 0.0 1.05000 0.95000 1.10000 0.90000 5 0.0

PSS® Activity SQEX

DATA FOR BUS 580071 [G10-041GEN1 0.6900] RESIDING IN AREA 645, ZONE 1, OWNER 1:

CODE ZERO SEQ LOAD NEG SEQ LOAD
2 0.0000 0.0000 0.0000 0.0000

ID ST MBASE ZGEN (POS.) ZGEN (NEG.) ZGEN (ZERO) X T R A N GENTAP
1 1 14.6 0.0000 0.2000 0.0000 0.2000 0.0000 0.8000 0.0000 0.0000 1.0000
(The exact value used for MBASE was 14.646.)

X----- TO BUS -----X S W C X----- ZERO SEQUENCE -----X X-- POS & NEG --X MAGNETIZING Y X--WINDING 1-X WINDNG2 X-- POS & NEG --X
BUS# X-- NAME --X BASKV CKT T 1 C R X RGROUND XGROUND R X G B RATIO ANGLE RATIO TAB NOMINAL R,X
648500 FLTWTX9 34.500 1 1 T 3 0.04089 0.40887 0.00000 0.00000 0.04089 0.40887 0.00000 0.00000 1.00000 0.0 1.00000 0

DATA FOR BUS 645061 [FLTWTX1W 0.5750] RESIDING IN AREA 645, ZONE 691, OWNER 645:

CODE ZERO SEQ LOAD NEG SEQ LOAD
2 0.0000 0.0000 0.0000 0.0000

ID ST MBASE ZGEN (POS.) ZGEN (NEG.) ZGEN (ZERO) X T R A N GENTAP
1 1 68.7 0.0000 0.2000 0.0000 0.2000 0.0000 0.8000 0.0000 0.0000 1.0000
(The exact value used for MBASE was 68.667.)

X----- TO BUS -----X S W C X----- ZERO SEQUENCE -----X X-- POS & NEG --X MAGNETIZING Y X--WINDING 1-X WINDNG2 X-- POS & NEG --X
BUS# X-- NAME --X BASKV CKT T 1 C R X RGROUND XGROUND R X G B RATIO ANGLE RATIO TAB NOMINAL R,X
648500 FLTWTX9 34.500 1 1 T 3 0.01086 0.08142 0.00000 0.00000 0.01086 0.08142 0.00000 0.00000 1.00000 0.0 1.00000 0
(The exact values used for R and X were 0.010856 and 0.081422, respectively, for the positive-, negative-, and zero-sequence networks.)

DATA FOR BUS 646399 [S1399 5 161.00] RESIDING IN AREA 645, ZONE 691, OWNER 645:

CODE ZERO SEQ LOAD NEG SEQ LOAD
1 0.0000 0.0000 0.0000 0.0000

X----- TO BUS -----X X- POS AND NEG SEQUENCE -X X---- ZERO SEQUENCE -----X
BUS# X-- NAME --X BASKV CKT LINE R LINE X CHARGING LINE R LINE X CHARGING ST ZI
54016 2007-15T 161.00 1 0.00097 0.00910 0.00461 0.00690 0.02780 0.00351 1
64863 HUMBOLT5 161.00 1 0.00457 0.03469 0.01778 0.03149 0.09474 0.01128 1

X- XFRMER -X S X----- WINDING BUS -----X S C X----- ZERO SEQUENCE -----X X-- POS & NEG --X X-- POS & NEG --X
X-- NAME --X CKT T CC BUS# X-- NAME --X BASKV T C R X RGROUND XGROUND R X RATIO ANGLE TAB NOMINAL R,X
WIND-TX 1 1 2 646399 S1399 5 161.00 1 1 0.02176 0.18073 0.00300 0.10419 1.02500 0.0 0
648500 FLTWTX9 34.500 1 1 -0.00251 -0.00291 0.00300 0.10419 1.00000 0.0 0
648501 FLTWTX9 13.800 1 3 0.01084 0.08567 0.00000 0.00000 0.00300 0.10419 1.00000 0.0 0

X- XFRMER -X S X----- WINDING 1 BUS -----X MAGNETIZING Y
X-- NAME --X CKT T BUS# X-- NAME --X BASKV G B
WIND-TX 1 1

646399 S1399 5

161.00 0.00000 0.00000

DATA FOR BUS 648500 [FLTWTRX9 34.500] RESIDING IN AREA 645, ZONE 691, OWNER 645:

CODE ZERO SEQ LOAD NEG SEQ LOAD
1 0.0000 0.0000 0.0000 0.0000

X----- TO BUS -----X S W C X----- ZERO SEQUENCE -----X X-- POS & NEG --X MAGNETIZING Y X--WINDING 1-X WINDNG2 X-- POS & NEG --X
BUS# X-- NAME --X BASKV CKT T 1 C R X RGROUND XGROUND R X G B RATIO ANGLE TAB RATIO TAB NOMINAL R,X
580071 G10-041GEN1 0.6900 1 1 F 3 0.04089 0.40887 0.00000 0.00000 0.04089 0.40887 0.00000 0.00000 1.00000 0.0 1.00000 0
645061 FLTWTR1W 0.5750 1 1 F 3 0.01086 0.08142 0.00000 0.00000 0.01086 0.08142 0.00000 0.00000 1.00000 0.0 1.00000 0
(The exact values used for R and X of the transformer to Bus 645061 were 0.010856 and 0.081422, respectively, for the positive-, negative-, and zero-
sequence networks.)

X- XFRMER -X S X----- WINDING BUS -----X S C X----- ZERO SEQUENCE -----X X-- POS & NEG --X X-- POS & NEG --X
X-- NAME --X CKT T CC BUS# X-- NAME --X BASKV T C R X RGROUND XGROUND R X RATIO ANGLE TAB NOMINAL R,X
WIND-TX 1 1 2 646399 S1399 5 161.00 1 1 0.02176 0.18073 0.00300 0.10419 1.02500 0.0 0
648500 FLTWTRX9 34.500 1 1 -0.00251 -0.00291 0.00300 0.10419 1.00000 0.0 0
648501 FLTWTRY9 13.800 1 3 0.01084 0.08567 0.00000 0.00000 0.00300 0.10419 1.00000 0.0 0

X- XFRMER -X S X---- WINDING 1 BUS ----X MAGNETIZING Y
X-- NAME --X CKT T BUS# X-- NAME --X BASKV G B
WIND-TX 1 1 646399 S1399 5 161.00 0.00000 0.00000

DATA FOR BUS 648501 [FLTWTRY9 13.800] RESIDING IN AREA 645, ZONE 691, OWNER 645:

CODE ZERO SEQ LOAD NEG SEQ LOAD
1 0.0000 0.0000 0.0000 0.0000

X- XFRMER -X S X----- WINDING BUS -----X S C X----- ZERO SEQUENCE -----X X-- POS & NEG --X X-- POS & NEG --X
X-- NAME --X CKT T CC BUS# X-- NAME --X BASKV T C R X RGROUND XGROUND R X RATIO ANGLE TAB NOMINAL R,X
WIND-TX 1 1 2 646399 S1399 5 161.00 1 1 0.02176 0.18073 0.00300 0.10419 1.02500 0.0 0
648500 FLTWTRX9 34.500 1 1 -0.00251 -0.00291 0.00300 0.10419 1.00000 0.0 0
648501 FLTWTRY9 13.800 1 3 0.01084 0.08567 0.00000 0.00000 0.00300 0.10419 1.00000 0.0 0

X- XFRMER -X S X---- WINDING 1 BUS ----X MAGNETIZING Y
X-- NAME --X CKT T BUS# X-- NAME --X BASKV G B
WIND-TX 1 1 646399 S1399 5 161.00 0.00000 0.00000

Appendix C. Contingency Analysis Results

**Table C-1: 2012 Spring Contingency Analysis Thermal Violations
NERC Category B and C Single-Event Contingencies
Loading Limit 100%, DF > 3%, Screened
GEN-2010-041 10.5 MW Wind Project**

FromBusNum	FromBusName	ToBusNum	ToBusName	Circuit	Rating	Benchmark (%)	Change (%)	DF	Prior	Contingency
640088	BPS SUB7 115.0	640111	CLATONA7 115.0	1	137	102.6	103.2	7.6%	Intact	XS640088>640278>\$1
635034	CLRNDA 5 161.0	560001	NODAWAYCO 161.0	1	153	159	159.2	3.8%	Intact	CB3458-40&CO

**Table C-2: 2012 Summer Contingency Analysis Thermal Violations
NERC Category B and C Single-Event Contingencies
Loading Limit 100%, DF > 3%, Screened
GEN-2010-041 10.5 MW Wind Project**

FromBusNum	FromBusName	ToBusNum	ToBusName	Circuit	Rating	Benchmark (%)	Change (%)	DF	Prior	Contingency
635034	CLRNDA 5 161.0	560001	NODAWAYCO 161.0	1	153	160.9	161.2	3.8%	Intact	CBCB-CB3-RLH
635034	CLRNDA 5 161.0	560001	NODAWAYCO 161.0	1	153	157.3	157.5	3.8%	Intact	RAUN-NEAL4T1
635034	CLRNDA 5 161.0	560001	NODAWAYCO 161.0	1	153	156.3	156.5	3.8%	Intact	FCS_GEN
635034	CLRNDA 5 161.0	560001	NODAWAYCO 161.0	1	153	153.6	153.9	3.8%	Intact	CB3456-58&T4
635034	CLRNDA 5 161.0	560001	NODAWAYCO 161.0	1	153	152.9	153.1	3.8%	Intact	XS645458>645458>\$1
635034	CLRNDA 5 161.0	560001	NODAWAYCO 161.0	1	153	150.9	151.2	3.8%	Intact	XS640139>560620>\$1
635034	CLRNDA 5 161.0	560001	NODAWAYCO 161.0	1	153	149.9	150.1	3.8%	Intact	XS645458>645740>\$1
635034	CLRNDA 5 161.0	560001	NODAWAYCO 161.0	1	153	149.6	149.9	3.8%	Intact	XS652507>652540>\$1

635034	CLRND 5 161.0	560001	NODAWAYCO 161.0	1	153	149.3	149.5	3.8%	Intact	CB3458-40&CO
635034	CLRND 5 161.0	560001	NODAWAYCO 161.0	1	153	148.8	149	3.8%	Intact	XS641087>641089>\$1
635034	CLRND 5 161.0	560001	NODAWAYCO 161.0	1	153	148.7	148.9	3.8%	Intact	XS652507>652541>\$1
635034	CLRND 5 161.0	560001	NODAWAYCO 161.0	1	153	148.3	148.5	3.8%	Intact	CB121150&NO2
635034	CLRND 5 161.0	560001	NODAWAYCO 161.0	1	153	148.1	148.4	3.8%	Intact	CBFREM-A
635034	CLRND 5 161.0	560001	NODAWAYCO 161.0	1	153	148.1	148.3	3.8%	Intact	CASS CO2 GEN
635034	CLRND 5 161.0	560001	NODAWAYCO 161.0	1	153	148.1	148.3	3.8%	Intact	CASS CO1 GEN
635034	CLRND 5 161.0	560001	NODAWAYCO 161.0	1	153	147.9	148.2	3.8%	Intact	XS640139>645458>\$1
635034	CLRND 5 161.0	560001	NODAWAYCO 161.0	1	153	148	148.2	3.8%	Intact	XS928113>640139>\$1
635034	CLRND 5 161.0	560001	NODAWAYCO 161.0	1	153	147.9	148.1	3.8%	Intact	CBWAG-T2-103
635034	CLRND 5 161.0	560001	NODAWAYCO 161.0	1	153	147.4	147.7	3.8%	Intact	XS640234>646399>\$1
635034	CLRND 5 161.0	560001	NODAWAYCO 161.0	1	153	147.4	147.7	3.8%	Intact	BKR-HMB-1604
635034	CLRND 5 161.0	560001	NODAWAYCO 161.0	1	153	147.2	147.5	3.8%	Intact	XS631134>635870>\$1
635034	CLRND 5 161.0	560001	NODAWAYCO 161.0	1	153	147.2	147.5	3.8%	Intact	XS646258>646263>\$1
635034	CLRND 5 161.0	560001	NODAWAYCO 161.0	1	153	147.2	147.5	3.8%	Intact	XS646244>646258>\$1
635034	CLRND 5 161.0	560001	NODAWAYCO 161.0	1	153	147.1	147.3	3.8%	Intact	CBHUM-80&T4
635034	CLRND 5 161.0	560001	NODAWAYCO 161.0	1	153	147	147.2	3.8%	Intact	CB1399-BUS
635034	CLRND 5 161.0	560001	NODAWAYCO 161.0	1	153	146.9	147.1	3.8%	Intact	XS635640>635641>\$1
635034	CLRND 5 161.0	560001	NODAWAYCO 161.0	1	153	146.9	147.1	3.8%	Intact	XS631166>631171>\$1
635034	CLRND 5 161.0	560001	NODAWAYCO 161.0	1	153	146.9	147.1	3.8%	Intact	XS652573>659206>\$1
635034	CLRND 5 161.0	560001	NODAWAYCO 161.0	1	153	146.9	147.1	3.8%	Intact	D-CIRCUIT#12
635034	CLRND 5 161.0	560001	NODAWAYCO 161.0	1	153	146.9	147.1	3.8%	Intact	BKR-HLD-3006
635034	CLRND 5 161.0	560001	NODAWAYCO 161.0	1	153	146.8	147	3.8%	Intact	XS635003>635004>\$1
635034	CLRND 5 161.0	560001	NODAWAYCO 161.0	1	153	146.8	147	3.8%	Intact	XS631112>344001>\$1
635034	CLRND 5 161.0	560001	NODAWAYCO 161.0	1	153	146.8	147	3.8%	Intact	XS636400>636420>\$1

635034	CLRND 5 161.0	560001	NODAWAYCO 161.0	1	153	146.8	147	3.8%	Intact	MC1221-31-55
635034	CLRND 5 161.0	560001	NODAWAYCO 161.0	1	153	146.7	146.9	3.8%	Intact	XS635041>635042>\$1
635034	CLRND 5 161.0	560001	NODAWAYCO 161.0	1	153	146.7	146.9	3.8%	Intact	XS635041>635043>\$2
635034	CLRND 5 161.0	560001	NODAWAYCO 161.0	1	153	146.7	146.9	3.8%	Intact	XS635310>635320>\$1
635034	CLRND 5 161.0	560001	NODAWAYCO 161.0	1	153	146.7	146.9	3.8%	Intact	XS635330>635331>\$1
635034	CLRND 5 161.0	560001	NODAWAYCO 161.0	1	153	146.7	146.9	3.8%	Intact	S3454T1 AUTO
635034	CLRND 5 161.0	560001	NODAWAYCO 161.0	1	153	146.7	146.9	3.8%	Intact	FRE7 GEN
635034	CLRND 5 161.0	560001	NODAWAYCO 161.0	1	153	146.7	146.9	3.8%	Intact	CB1254-BUS
635034	CLRND 5 161.0	560001	NODAWAYCO 161.0	1	153	146.6	146.9	3.8%	Intact	XS636029>636028>\$1
635034	CLRND 5 161.0	560001	NODAWAYCO 161.0	1	153	146.6	146.8	3.8%	Intact	XS646206>646244>\$1
635034	CLRND 5 161.0	560001	NODAWAYCO 161.0	1	153	146.6	146.8	3.8%	Intact	XS652507>652606>\$1
635034	CLRND 5 161.0	560001	NODAWAYCO 161.0	1	153	146.6	146.8	3.8%	Intact	XS631076>345827>\$1
635034	CLRND 5 161.0	560001	NODAWAYCO 161.0	1	153	146.6	146.8	3.8%	Intact	XS631075>631076>\$1
635034	CLRND 5 161.0	560001	NODAWAYCO 161.0	1	153	146.6	146.8	3.8%	Intact	XS636235>636237>\$1
635034	CLRND 5 161.0	560001	NODAWAYCO 161.0	1	153	146.5	146.7	3.8%	Intact	XS635032>635033>\$1
635034	CLRND 5 161.0	560001	NODAWAYCO 161.0	1	153	146.5	146.7	3.8%	Intact	XS631154>631151>\$1
635034	CLRND 5 161.0	560001	NODAWAYCO 161.0	1	153	146.5	146.7	3.8%	Intact	XS631154>631150>\$1
635034	CLRND 5 161.0	560001	NODAWAYCO 161.0	1	153	146.5	146.7	3.8%	Intact	XS636600>636605>\$1
635034	CLRND 5 161.0	560001	NODAWAYCO 161.0	1	153	146.5	146.7	3.8%	Intact	XS640169>640218>\$1
635034	CLRND 5 161.0	560001	NODAWAYCO 161.0	1	153	146.5	146.7	3.8%	Intact	XS640088>640111>\$1
635034	CLRND 5 161.0	560001	NODAWAYCO 161.0	1	153	146.5	146.7	3.8%	Intact	XS640093>640286>\$1
635034	CLRND 5 161.0	560001	NODAWAYCO 161.0	1	153	146.4	146.7	3.8%	Intact	XS640183>640374>\$1
635034	CLRND 5 161.0	560001	NODAWAYCO 161.0	1	153	146.4	146.7	3.8%	Intact	XS640234>646280>\$1
635034	CLRND 5 161.0	560001	NODAWAYCO 161.0	1	153	146.5	146.7	3.8%	Intact	XS647102>647970>\$1
635034	CLRND 5 161.0	560001	NODAWAYCO 161.0	1	153	146.5	146.7	3.8%	Intact	XS647102>647974>\$1

635034	CLRND 5 161.0	560001	NODAWAYCO 161.0	1	153	146.4	146.7	3.8%	Intact	XS646251>646297>\$1
635034	CLRND 5 161.0	560001	NODAWAYCO 161.0	1	153	146.5	146.7	3.8%	Intact	XS646399>648500>648501\$1
635034	CLRND 5 161.0	560001	NODAWAYCO 161.0	1	153	146.4	146.7	3.8%	Intact	TWR-SCH-NH
635034	CLRND 5 161.0	560001	NODAWAYCO 161.0	1	153	146.4	146.7	3.8%	Intact	XS300058>344697>\$1
635034	CLRND 5 161.0	560001	NODAWAYCO 161.0	1	153	146.4	146.7	3.8%	Intact	XS300101>505498>\$1
635034	CLRND 5 161.0	560001	NODAWAYCO 161.0	1	153	146.5	146.7	3.8%	Intact	XS532796>514715>\$1
635034	CLRND 5 161.0	560001	NODAWAYCO 161.0	1	153	146.5	146.7	3.8%	Intact	XS533036>539675>\$1
635034	CLRND 5 161.0	560001	NODAWAYCO 161.0	1	153	146.4	146.7	3.8%	Intact	XS533302>533308>\$1
635034	CLRND 5 161.0	560001	NODAWAYCO 161.0	1	153	146.4	146.7	3.8%	Intact	XS533151>533155>\$1
635034	CLRND 5 161.0	560001	NODAWAYCO 161.0	1	153	146.4	146.7	3.8%	Intact	XS533369>533380>\$1
635034	CLRND 5 161.0	560001	NODAWAYCO 161.0	1	153	146.4	146.7	3.8%	Intact	XS652529>659160>\$1
635034	CLRND 5 161.0	560001	NODAWAYCO 161.0	1	153	146.5	146.7	3.8%	Intact	ENRONTAP
635034	CLRND 5 161.0	560001	NODAWAYCO 161.0	1	153	146.5	146.7	3.8%	Intact	CB914A-46-T1
635034	CLRND 5 161.0	560001	NODAWAYCO 161.0	1	153	146.5	146.7	3.8%	Intact	XS542969>543057>\$1
635034	CLRND 5 161.0	560001	NODAWAYCO 161.0	1	153	146.5	146.7	3.8%	Intact	XS631070>630009>\$1
635034	CLRND 5 161.0	560001	NODAWAYCO 161.0	1	153	146.5	146.7	3.8%	Intact	XS631061>631140>\$1
635034	CLRND 5 161.0	560001	NODAWAYCO 161.0	1	153	146.5	146.7	3.8%	Intact	XS543060>344558>\$1
635034	CLRND 5 161.0	560001	NODAWAYCO 161.0	1	153	146.4	146.6	3.8%	Intact	XS635203>635235>\$1
635034	CLRND 5 161.0	560001	NODAWAYCO 161.0	1	153	146.4	146.6	3.8%	Intact	XS635601>635602>\$1
635034	CLRND 5 161.0	560001	NODAWAYCO 161.0	1	153	146.4	146.6	3.8%	Intact	XS635606>635607>\$1
635034	CLRND 5 161.0	560001	NODAWAYCO 161.0	1	153	146.4	146.6	3.8%	Intact	XS635235>635236>\$1
635034	CLRND 5 161.0	560001	NODAWAYCO 161.0	1	153	146.4	146.6	3.8%	Intact	XS635360>635361>\$1
635034	CLRND 5 161.0	560001	NODAWAYCO 161.0	1	153	146.4	146.6	3.8%	Intact	XS635660>635661>\$1
635034	CLRND 5 161.0	560001	NODAWAYCO 161.0	1	153	146.4	146.6	3.8%	Intact	XS640065>640066>640067\$1
635034	CLRND 5 161.0	560001	NODAWAYCO 161.0	1	153	146.4	146.6	3.8%	Intact	XS636421>630679>\$1

635034	CLRND 5 161.0	560001	NODAWAYCO 161.0	1	153	146.4	146.6	3.8%	Intact	XS646255>646259>\$1
635034	CLRND 5 161.0	560001	NODAWAYCO 161.0	1	153	146.4	146.6	3.8%	Intact	XS647014>647914>\$1
635034	CLRND 5 161.0	560001	NODAWAYCO 161.0	1	153	146.4	146.6	3.8%	Intact	XS652312>659242>\$1
635034	CLRND 5 161.0	560001	NODAWAYCO 161.0	1	153	146.4	146.6	3.8%	Intact	XS532771>533416>532810\$1
635034	CLRND 5 161.0	560001	NODAWAYCO 161.0	1	153	146.4	146.6	3.8%	Intact	XS532851>533151>532880\$1
635034	CLRND 5 161.0	560001	NODAWAYCO 161.0	1	153	146.4	146.6	3.8%	Intact	XS532797>533653>\$1
635034	CLRND 5 161.0	560001	NODAWAYCO 161.0	1	153	146.4	146.6	3.8%	Intact	XS532985>532992>\$1
635034	CLRND 5 161.0	560001	NODAWAYCO 161.0	1	153	146.4	146.6	3.8%	Intact	XS659132>659187>\$1
635034	CLRND 5 161.0	560001	NODAWAYCO 161.0	1	153	146.4	146.6	3.8%	Intact	XS652504>652474>\$1
635034	CLRND 5 161.0	560001	NODAWAYCO 161.0	1	153	146.4	146.6	3.8%	Intact	CB1235-34&53
635034	CLRND 5 161.0	560001	NODAWAYCO 161.0	1	153	146.4	146.6	3.8%	Intact	LES8506
635034	CLRND 5 161.0	560001	NODAWAYCO 161.0	1	153	146.4	146.6	3.8%	Intact	XS542978>543048>\$1
635034	CLRND 5 161.0	560001	NODAWAYCO 161.0	1	153	146.4	146.6	3.8%	Intact	XS543016>543029>\$1
635034	CLRND 5 161.0	560001	NODAWAYCO 161.0	1	153	146.4	146.6	3.8%	Intact	XS541212>541213>\$1
635034	CLRND 5 161.0	560001	NODAWAYCO 161.0	1	153	146.4	146.6	3.8%	Intact	XS542973>542997>\$2
635034	CLRND 5 161.0	560001	NODAWAYCO 161.0	1	153	146.4	146.6	3.8%	Intact	XS542997>543009>\$1
635034	CLRND 5 161.0	560001	NODAWAYCO 161.0	1	153	146.4	146.6	3.8%	Intact	XS631066>681520>\$1
635034	CLRND 5 161.0	560001	NODAWAYCO 161.0	1	153	146.4	146.6	3.8%	Intact	XS631075>344290>\$1
635034	CLRND 5 161.0	560001	NODAWAYCO 161.0	1	153	146.4	146.6	3.8%	Intact	XS560141>560142>\$1
635034	CLRND 5 161.0	560001	NODAWAYCO 161.0	1	153	146.4	146.6	3.8%	Intact	XS543071>543072>\$1
635034	CLRND 5 161.0	560001	NODAWAYCO 161.0	1	153	146.4	146.6	3.8%	Intact	XS560142>560143>\$1
635034	CLRND 5 161.0	560001	NODAWAYCO 161.0	1	153	146.4	146.6	3.8%	Intact	XS631084>344290>\$1
635034	CLRND 5 161.0	560001	NODAWAYCO 161.0	1	153	146.4	146.6	3.8%	Intact	XS543055>543077>\$1
635034	CLRND 5 161.0	560001	NODAWAYCO 161.0	1	153	146.2	146.5	3.8%	Intact	XS636001>656353>\$1
635034	CLRND 5 161.0	560001	NODAWAYCO 161.0	1	153	146.2	146.5	3.8%	Intact	XS640155>640156>\$1

635034	CLRND 5 161.0	560001	NODAWAYCO 161.0	1	153	146.2	146.5	3.8%	Intact	XS640133>640343>\$1
635034	CLRND 5 161.0	560001	NODAWAYCO 161.0	1	153	146.2	146.5	3.8%	Intact	XS640058>640165>\$1
635034	CLRND 5 161.0	560001	NODAWAYCO 161.0	1	153	146.2	146.5	3.8%	Intact	XS640173>640281>\$1
635034	CLRND 5 161.0	560001	NODAWAYCO 161.0	1	153	146.2	146.5	3.8%	Intact	XS640342>640343>643136\$1
635034	CLRND 5 161.0	560001	NODAWAYCO 161.0	1	153	146.3	146.5	3.8%	Intact	XS645021>645121>\$1
635034	CLRND 5 161.0	560001	NODAWAYCO 161.0	1	153	146.2	146.5	3.8%	Intact	XS640392>640394>\$1
635034	CLRND 5 161.0	560001	NODAWAYCO 161.0	1	153	146.2	146.5	3.8%	Intact	XS645100>645103>\$1
635034	CLRND 5 161.0	560001	NODAWAYCO 161.0	1	153	146.2	146.5	3.8%	Intact	XS640349>640350>\$1
635034	CLRND 5 161.0	560001	NODAWAYCO 161.0	1	153	146.3	146.5	3.8%	Intact	XS640271>652571>\$1
635034	CLRND 5 161.0	560001	NODAWAYCO 161.0	1	153	146.3	146.5	3.8%	Intact	XS647919>647930>\$1
635034	CLRND 5 161.0	560001	NODAWAYCO 161.0	1	153	146.2	146.5	3.8%	Intact	XS646231>646235>\$1
635034	CLRND 5 161.0	560001	NODAWAYCO 161.0	1	153	146.2	146.5	3.8%	Intact	XS647902>647937>\$1
635034	CLRND 5 161.0	560001	NODAWAYCO 161.0	1	153	146.2	146.5	3.8%	Intact	XS646211>646299>\$1
635034	CLRND 5 161.0	560001	NODAWAYCO 161.0	1	153	146.2	146.5	3.8%	Intact	MC930-18-19
635034	CLRND 5 161.0	560001	NODAWAYCO 161.0	1	153	146.2	146.5	3.8%	Intact	XS300597>344535>\$1
635034	CLRND 5 161.0	560001	NODAWAYCO 161.0	1	153	146.2	146.5	3.8%	Intact	XS300867>505550>\$1
635034	CLRND 5 161.0	560001	NODAWAYCO 161.0	1	153	146.2	146.5	3.8%	Intact	XS300122>300917>\$1
635034	CLRND 5 161.0	560001	NODAWAYCO 161.0	1	153	146.3	146.5	3.8%	Intact	XS532934>532937>\$1
635034	CLRND 5 161.0	560001	NODAWAYCO 161.0	1	153	146.2	146.5	3.8%	Intact	XS300867>505522>\$1
635034	CLRND 5 161.0	560001	NODAWAYCO 161.0	1	153	146.2	146.5	3.8%	Intact	XS300595>345498>\$1
635034	CLRND 5 161.0	560001	NODAWAYCO 161.0	1	153	146.3	146.5	3.8%	Intact	XS533235>533283>\$1
635034	CLRND 5 161.0	560001	NODAWAYCO 161.0	1	153	146.3	146.5	3.8%	Intact	XS533235>533240>\$1
635034	CLRND 5 161.0	560001	NODAWAYCO 161.0	1	153	146.2	146.5	3.8%	Intact	CB1235-31&36
635034	CLRND 5 161.0	560001	NODAWAYCO 161.0	1	153	146.2	146.5	3.8%	Intact	CB1250-11&T1
635034	CLRND 5 161.0	560001	NODAWAYCO 161.0	1	153	146.3	146.5	3.8%	Intact	LES1402A

635034	CLRND 5 161.0	560001	NODAWAYCO 161.0	1	153	146.3	146.5	3.8%	Intact	XS542978>543038>\$1
635034	CLRND 5 161.0	560001	NODAWAYCO 161.0	1	153	146.3	146.5	3.8%	Intact	XS541225>541243>\$1
635034	CLRND 5 161.0	560001	NODAWAYCO 161.0	1	153	146.3	146.5	3.8%	Intact	XS542966>543049>\$1
635034	CLRND 5 161.0	560001	NODAWAYCO 161.0	1	153	146.2	146.5	3.8%	Intact	XS541237>541238>\$1
635034	CLRND 5 161.0	560001	NODAWAYCO 161.0	1	153	146.3	146.5	3.8%	Intact	XS542977>542978>543643\$33
635034	CLRND 5 161.0	560001	NODAWAYCO 161.0	1	153	146.3	146.5	3.8%	Intact	XS542993>543001>\$1
635034	CLRND 5 161.0	560001	NODAWAYCO 161.0	1	153	146.2	146.5	3.8%	Intact	XS631087>629103>\$1
635034	CLRND 5 161.0	560001	NODAWAYCO 161.0	1	153	146.3	146.5	3.8%	Intact	XS543059>543063>\$1
635034	CLRND 5 161.0	560001	NODAWAYCO 161.0	1	153	146.2	146.5	3.8%	Intact	XS631060>681519>\$1
635034	CLRND 5 161.0	560001	NODAWAYCO 161.0	1	153	146.3	146.5	3.8%	Intact	XS631163>629983>\$1
635034	CLRND 5 161.0	560001	NODAWAYCO 161.0	1	153	146.3	146.5	3.8%	Intact	XS631155>631169>\$1
635034	CLRND 5 161.0	560001	NODAWAYCO 161.0	1	153	146.3	146.5	3.8%	Intact	XS631144>631157>\$1
635034	CLRND 5 161.0	560001	NODAWAYCO 161.0	1	153	146.3	146.5	3.8%	Intact	XS631102>630023>\$2
635034	CLRND 5 161.0	560001	NODAWAYCO 161.0	1	153	146.3	146.5	3.8%	Intact	XS631127>630128>\$1
635034	CLRND 5 161.0	560001	NODAWAYCO 161.0	1	153	146.3	146.5	3.8%	Intact	XS631155>631152>\$1
635034	CLRND 5 161.0	560001	NODAWAYCO 161.0	1	153	146.3	146.5	3.8%	Intact	XS631098>629091>\$1
635034	CLRND 5 161.0	560001	NODAWAYCO 161.0	1	153	146.3	146.5	3.8%	Intact	XS635604>635610>\$1
635034	CLRND 5 161.0	560001	NODAWAYCO 161.0	1	153	146.3	146.5	3.8%	Intact	XS635662>635663>\$2
635034	CLRND 5 161.0	560001	NODAWAYCO 161.0	1	153	146.3	146.5	3.8%	Intact	XS631164>629984>\$1
635034	CLRND 5 161.0	560001	NODAWAYCO 161.0	1	153	146.3	146.5	3.8%	Intact	XS635662>635663>\$1
635034	CLRND 5 161.0	560001	NODAWAYCO 161.0	1	153	146.3	146.5	3.8%	Intact	XS635710>638000>\$1
635034	CLRND 5 161.0	560001	NODAWAYCO 161.0	1	153	146.3	146.5	3.8%	Intact	XS635631>635641>\$1
635034	CLRND 5 161.0	560001	NODAWAYCO 161.0	1	153	146.3	146.5	3.8%	Intact	XS631106>300439>\$2
635034	CLRND 5 161.0	560001	NODAWAYCO 161.0	1	153	146.3	146.5	3.8%	Intact	XS636023>636025>\$1
635034	CLRND 5 161.0	560001	NODAWAYCO 161.0	1	153	146.3	146.5	3.8%	Intact	XS631138>629992>\$1

635034	CLRND 5 161.0	560001	NODAWAYCO 161.0	1	153	146.3	146.5	3.8%	Intact	XS631102>630023>\$1
635034	CLRND 5 161.0	560001	NODAWAYCO 161.0	1	153	146.3	146.5	3.8%	Intact	XS636020>636023>\$1
635034	CLRND 5 161.0	560001	NODAWAYCO 161.0	1	153	146.3	146.5	3.8%	Intact	XS631117>631119>\$1
635034	CLRND 5 161.0	560001	NODAWAYCO 161.0	1	153	146.3	146.5	3.8%	Intact	XS636020>636021>\$3
635034	CLRND 5 161.0	560001	NODAWAYCO 161.0	1	153	146.3	146.5	3.8%	Intact	XS631134>629985>\$1
635034	CLRND 5 161.0	560001	NODAWAYCO 161.0	1	153	146.3	146.5	3.8%	Intact	XS636029>636030>\$1
635034	CLRND 5 161.0	560001	NODAWAYCO 161.0	1	153	146.3	146.5	3.8%	Intact	XS631146>631147>\$1
635034	CLRND 5 161.0	560001	NODAWAYCO 161.0	1	153	146.3	146.5	3.8%	Intact	XS636020>636021>\$1
635034	CLRND 5 161.0	560001	NODAWAYCO 161.0	1	153	146.3	146.5	3.8%	Intact	XS635260>635360>\$1
635034	CLRND 5 161.0	560001	NODAWAYCO 161.0	1	153	146.3	146.5	3.8%	Intact	XS631106>300439>\$1
635034	CLRND 5 161.0	560001	NODAWAYCO 161.0	1	153	146.3	146.5	3.8%	Intact	XS631134>629985>\$2
635034	CLRND 5 161.0	560001	NODAWAYCO 161.0	1	153	146.3	146.5	3.8%	Intact	XS635340>636029>\$1
635034	CLRND 5 161.0	560001	NODAWAYCO 161.0	1	153	146.3	146.5	3.8%	Intact	XS631156>631153>\$1
635034	CLRND 5 161.0	560001	NODAWAYCO 161.0	1	153	146.3	146.5	3.8%	Intact	XS631144>631158>\$1
635034	CLRND 5 161.0	560001	NODAWAYCO 161.0	1	153	146.3	146.5	3.8%	Intact	XS631103>630821>\$1
635034	CLRND 5 161.0	560001	NODAWAYCO 161.0	1	153	146.3	146.5	3.8%	Intact	XS636020>636021>\$2
635034	CLRND 5 161.0	560001	NODAWAYCO 161.0	1	153	146.3	146.5	3.8%	Intact	XS636200>636205>\$1
635034	CLRND 5 161.0	560001	NODAWAYCO 161.0	1	153	146.3	146.5	3.8%	Intact	XS635320>635321>\$1
635034	CLRND 5 161.0	560001	NODAWAYCO 161.0	1	153	146.3	146.5	3.8%	Intact	XS635100>635101>\$2
635034	CLRND 5 161.0	560001	NODAWAYCO 161.0	1	153	146.3	146.5	3.8%	Intact	XS631122>630139>\$1
635034	CLRND 5 161.0	560001	NODAWAYCO 161.0	1	153	146.3	146.5	3.8%	Intact	XS636202>636203>\$1
635034	CLRND 5 161.0	560001	NODAWAYCO 161.0	1	153	146.3	146.5	3.8%	Intact	XS631169>629987>\$1
635034	CLRND 5 161.0	560001	NODAWAYCO 161.0	1	153	146.3	146.5	3.8%	Intact	XS631122>631123>\$1
635034	CLRND 5 161.0	560001	NODAWAYCO 161.0	1	153	146.3	146.5	3.8%	Intact	XS635320>635321>\$2
635034	CLRND 5 161.0	560001	NODAWAYCO 161.0	1	153	146.3	146.5	3.8%	Intact	XS635701>635702>\$1

635034	CLRND 5 161.0	560001	NODAWAYCO 161.0	1	153	146.3	146.5	3.8%	Intact	XS635201>635203>\$1
635034	CLRND 5 161.0	560001	NODAWAYCO 161.0	1	153	146.3	146.5	3.8%	Intact	XS631166>636230>\$1
635034	CLRND 5 161.0	560001	NODAWAYCO 161.0	1	153	146.3	146.5	3.8%	Intact	XS635100>635101>\$1
635034	CLRND 5 161.0	560001	NODAWAYCO 161.0	1	153	146.3	146.5	3.8%	Intact	XS631098>629091>\$2
635034	CLRND 5 161.0	560001	NODAWAYCO 161.0	1	153	146.3	146.5	3.8%	Intact	XS631122>613040>\$1
635034	CLRND 5 161.0	560001	NODAWAYCO 161.0	1	153	146.3	146.5	3.8%	Intact	XS636200>636202>\$1
635034	CLRND 5 161.0	560001	NODAWAYCO 161.0	1	153	146.3	146.5	3.8%	Intact	XS635701>635702>\$2
635034	CLRND 5 161.0	560001	NODAWAYCO 161.0	1	153	146.3	146.5	3.8%	Intact	XS631164>631183>\$1
635034	CLRND 5 161.0	560001	NODAWAYCO 161.0	1	153	146.3	146.5	3.8%	Intact	XS635201>635220>\$1
635034	CLRND 5 161.0	560001	NODAWAYCO 161.0	1	153	146.3	146.5	3.8%	Intact	XS635201>635203>\$2
635034	CLRND 5 161.0	560001	NODAWAYCO 161.0	1	153	146.3	146.5	3.8%	Intact	XS636410>636411>\$1
635034	CLRND 5 161.0	560001	NODAWAYCO 161.0	1	153	146.3	146.5	3.8%	Intact	XS638050>638051>\$2
635034	CLRND 5 161.0	560001	NODAWAYCO 161.0	1	153	146.3	146.5	3.8%	Intact	XS636665>636667>\$1
635034	CLRND 5 161.0	560001	NODAWAYCO 161.0	1	153	146.3	146.5	3.8%	Intact	XS636410>636422>\$1
635034	CLRND 5 161.0	560001	NODAWAYCO 161.0	1	153	146.3	146.5	3.8%	Intact	XS636410>636415>\$1
635034	CLRND 5 161.0	560001	NODAWAYCO 161.0	1	153	146.3	146.5	3.8%	Intact	XS640076>640077>\$2
635034	CLRND 5 161.0	560001	NODAWAYCO 161.0	1	153	146.3	146.5	3.8%	Intact	XS636405>636410>\$1
635034	CLRND 5 161.0	560001	NODAWAYCO 161.0	1	153	146.3	146.5	3.8%	Intact	XS640076>640077>\$1
635034	CLRND 5 161.0	560001	NODAWAYCO 161.0	1	153	146.3	146.5	3.8%	Intact	XS640140>640446>643173\$1
635034	CLRND 5 161.0	560001	NODAWAYCO 161.0	1	153	146.3	146.5	3.8%	Intact	XS636404>636405>\$1
635034	CLRND 5 161.0	560001	NODAWAYCO 161.0	1	153	146.3	146.5	3.8%	Intact	XS640076>640361>\$1
635034	CLRND 5 161.0	560001	NODAWAYCO 161.0	1	153	146.3	146.5	3.8%	Intact	XS636665>636666>\$1
635034	CLRND 5 161.0	560001	NODAWAYCO 161.0	1	153	146.3	146.5	3.8%	Intact	XS636670>636671>\$1
635034	CLRND 5 161.0	560001	NODAWAYCO 161.0	1	153	146.3	146.5	3.8%	Intact	XS640082>640083>\$2
635034	CLRND 5 161.0	560001	NODAWAYCO 161.0	1	153	146.3	146.5	3.8%	Intact	XS640082>640083>\$1

635034	CLRND 5 161.0	560001	NODAWAYCO 161.0	1	153	146.3	146.5	3.8%	Intact	XS638000>638010>\$1
635034	CLRND 5 161.0	560001	NODAWAYCO 161.0	1	153	146.3	146.5	3.8%	Intact	XS640125>640127>640129\$1
635034	CLRND 5 161.0	560001	NODAWAYCO 161.0	1	153	146.3	146.5	3.8%	Intact	XS638010>638011>\$1
635034	CLRND 5 161.0	560001	NODAWAYCO 161.0	1	153	146.3	146.5	3.8%	Intact	XS636668>636694>\$1
635034	CLRND 5 161.0	560001	NODAWAYCO 161.0	1	153	146.3	146.5	3.8%	Intact	XS640078>640357>\$1
635034	CLRND 5 161.0	560001	NODAWAYCO 161.0	1	153	146.3	146.5	3.8%	Intact	XS640119>640127>\$1
635034	CLRND 5 161.0	560001	NODAWAYCO 161.0	1	153	146.3	146.5	3.8%	Intact	XS640124>640136>\$1
635034	CLRND 5 161.0	560001	NODAWAYCO 161.0	1	153	146.3	146.5	3.8%	Intact	XS636401>636423>\$1
635034	CLRND 5 161.0	560001	NODAWAYCO 161.0	1	153	146.3	146.5	3.8%	Intact	XS640103>640005>\$1
635034	CLRND 5 161.0	560001	NODAWAYCO 161.0	1	153	146.3	146.5	3.8%	Intact	XS638050>638051>\$1
635034	CLRND 5 161.0	560001	NODAWAYCO 161.0	1	153	146.3	146.5	3.8%	Intact	XS636668>636670>\$1
635034	CLRND 5 161.0	560001	NODAWAYCO 161.0	1	153	146.3	146.5	3.8%	Intact	XS636403>636404>\$1
635034	CLRND 5 161.0	560001	NODAWAYCO 161.0	1	153	146.3	146.5	3.8%	Intact	XS636670>636671>\$2
635034	CLRND 5 161.0	560001	NODAWAYCO 161.0	1	153	146.3	146.5	3.8%	Intact	XS640149>640293>\$1
635034	CLRND 5 161.0	560001	NODAWAYCO 161.0	1	153	146.3	146.5	3.8%	Intact	XS640103>640161>\$1
635034	CLRND 5 161.0	560001	NODAWAYCO 161.0	1	153	146.3	146.5	3.8%	Intact	XS636605>274698>\$2
635034	CLRND 5 161.0	560001	NODAWAYCO 161.0	1	153	146.3	146.5	3.8%	Intact	XS640107>640108>\$1
635034	CLRND 5 161.0	560001	NODAWAYCO 161.0	1	153	146.3	146.5	3.8%	Intact	XS640151>640152>\$2
635034	CLRND 5 161.0	560001	NODAWAYCO 161.0	1	153	146.3	146.5	3.8%	Intact	XS640054>640055>\$2
635034	CLRND 5 161.0	560001	NODAWAYCO 161.0	1	153	146.3	146.5	3.8%	Intact	XS640151>640152>\$1
635034	CLRND 5 161.0	560001	NODAWAYCO 161.0	1	153	146.3	146.5	3.8%	Intact	XS636605>274698>\$1
635034	CLRND 5 161.0	560001	NODAWAYCO 161.0	1	153	146.3	146.5	3.8%	Intact	XS640113>640305>\$1
635034	CLRND 5 161.0	560001	NODAWAYCO 161.0	1	153	146.3	146.5	3.8%	Intact	XS640054>640055>\$1
635034	CLRND 5 161.0	560001	NODAWAYCO 161.0	1	153	146.3	146.5	3.8%	Intact	XS636616>636626>\$1
635034	CLRND 5 161.0	560001	NODAWAYCO 161.0	1	153	146.3	146.5	3.8%	Intact	XS640144>640196>\$1

635034	CLRND 5 161.0	560001	NODAWAYCO 161.0	1	153	146.3	146.5	3.8%	Intact	XS640056>640057>\$1
635034	CLRND 5 161.0	560001	NODAWAYCO 161.0	1	153	146.3	146.5	3.8%	Intact	XS640143>647973>\$1
635034	CLRND 5 161.0	560001	NODAWAYCO 161.0	1	153	146.3	146.5	3.8%	Intact	XS636625>636628>\$1
635034	CLRND 5 161.0	560001	NODAWAYCO 161.0	1	153	146.3	146.5	3.8%	Intact	XS640056>640057>\$2
635034	CLRND 5 161.0	560001	NODAWAYCO 161.0	1	153	146.3	146.5	3.8%	Intact	XS640107>640108>\$2
635034	CLRND 5 161.0	560001	NODAWAYCO 161.0	1	153	146.3	146.5	3.8%	Intact	XS640119>640122>\$1
635034	CLRND 5 161.0	560001	NODAWAYCO 161.0	1	153	146.3	146.5	3.8%	Intact	XS640136>640137>\$1
635034	CLRND 5 161.0	560001	NODAWAYCO 161.0	1	153	146.3	146.5	3.8%	Intact	XS636415>636425>\$1
635034	CLRND 5 161.0	560001	NODAWAYCO 161.0	1	153	146.3	146.5	3.8%	Intact	XS640119>640122>\$2
635034	CLRND 5 161.0	560001	NODAWAYCO 161.0	1	153	146.3	146.5	3.8%	Intact	XS636660>636662>\$1
635034	CLRND 5 161.0	560001	NODAWAYCO 161.0	1	153	146.3	146.5	3.8%	Intact	XS640119>640124>\$1
635034	CLRND 5 161.0	560001	NODAWAYCO 161.0	1	153	146.3	146.5	3.8%	Intact	XS636421>636422>\$1
635034	CLRND 5 161.0	560001	NODAWAYCO 161.0	1	153	146.3	146.5	3.8%	Intact	XS640151>640263>\$1
635034	CLRND 5 161.0	560001	NODAWAYCO 161.0	1	153	146.3	146.5	3.8%	Intact	XS636423>636425>\$1
635034	CLRND 5 161.0	560001	NODAWAYCO 161.0	1	153	146.3	146.5	3.8%	Intact	XS636662>636665>\$1
635034	CLRND 5 161.0	560001	NODAWAYCO 161.0	1	153	146.3	146.5	3.8%	Intact	XS640068>640246>\$1
635034	CLRND 5 161.0	560001	NODAWAYCO 161.0	1	153	146.3	146.5	3.8%	Intact	XS636650>636651>\$2
635034	CLRND 5 161.0	560001	NODAWAYCO 161.0	1	153	146.3	146.5	3.8%	Intact	XS636601>636660>\$1
635034	CLRND 5 161.0	560001	NODAWAYCO 161.0	1	153	146.3	146.5	3.8%	Intact	XS636601>636694>\$1
635034	CLRND 5 161.0	560001	NODAWAYCO 161.0	1	153	146.3	146.5	3.8%	Intact	XS640153>640154>\$2
635034	CLRND 5 161.0	560001	NODAWAYCO 161.0	1	153	146.3	146.5	3.8%	Intact	XS636650>636651>\$1
635034	CLRND 5 161.0	560001	NODAWAYCO 161.0	1	153	146.3	146.5	3.8%	Intact	XS640153>640154>\$1
635034	CLRND 5 161.0	560001	NODAWAYCO 161.0	1	153	146.3	146.5	3.8%	Intact	XS640136>640137>\$2
635034	CLRND 5 161.0	560001	NODAWAYCO 161.0	1	153	146.3	146.5	3.8%	Intact	XS640131>640132>643040\$2
635034	CLRND 5 161.0	560001	NODAWAYCO 161.0	1	153	146.3	146.5	3.8%	Intact	XS640173>647976>\$1

635034	CLRND 5 161.0	560001	NODAWAYCO 161.0	1	153	146.3	146.5	3.8%	Intact	XS636205>636207>\$1
635034	CLRND 5 161.0	560001	NODAWAYCO 161.0	1	153	146.3	146.5	3.8%	Intact	XS640089>640090>\$2
635034	CLRND 5 161.0	560001	NODAWAYCO 161.0	1	153	146.3	146.5	3.8%	Intact	XS636220>636223>\$1
635034	CLRND 5 161.0	560001	NODAWAYCO 161.0	1	153	146.3	146.5	3.8%	Intact	XS636682>636683>\$1
635034	CLRND 5 161.0	560001	NODAWAYCO 161.0	1	153	146.3	146.5	3.8%	Intact	XS636207>636208>\$1
635034	CLRND 5 161.0	560001	NODAWAYCO 161.0	1	153	146.3	146.5	3.8%	Intact	XS636685>636690>\$1
635034	CLRND 5 161.0	560001	NODAWAYCO 161.0	1	153	146.3	146.5	3.8%	Intact	XS636680>636681>\$1
635034	CLRND 5 161.0	560001	NODAWAYCO 161.0	1	153	146.3	146.5	3.8%	Intact	XS640127>640128>\$1
635034	CLRND 5 161.0	560001	NODAWAYCO 161.0	1	153	146.3	146.5	3.8%	Intact	XS640178>640372>\$1
635034	CLRND 5 161.0	560001	NODAWAYCO 161.0	1	153	146.3	146.5	3.8%	Intact	XS636681>636685>\$1
635034	CLRND 5 161.0	560001	NODAWAYCO 161.0	1	153	146.3	146.5	3.8%	Intact	XS636683>636685>\$1
635034	CLRND 5 161.0	560001	NODAWAYCO 161.0	1	153	146.3	146.5	3.8%	Intact	XS636205>636206>\$1
635034	CLRND 5 161.0	560001	NODAWAYCO 161.0	1	153	146.3	146.5	3.8%	Intact	XS640127>640128>\$2
635034	CLRND 5 161.0	560001	NODAWAYCO 161.0	1	153	146.3	146.5	3.8%	Intact	XS640127>640157>\$1
635034	CLRND 5 161.0	560001	NODAWAYCO 161.0	1	153	146.3	146.5	3.8%	Intact	XS636208>638040>\$1
635034	CLRND 5 161.0	560001	NODAWAYCO 161.0	1	153	146.3	146.5	3.8%	Intact	XS636203>636206>\$1
635034	CLRND 5 161.0	560001	NODAWAYCO 161.0	1	153	146.3	146.5	3.8%	Intact	XS636220>636222>\$1
635034	CLRND 5 161.0	560001	NODAWAYCO 161.0	1	153	146.3	146.5	3.8%	Intact	XS636685>636686>\$1
635034	CLRND 5 161.0	560001	NODAWAYCO 161.0	1	153	146.3	146.5	3.8%	Intact	XS636208>636220>\$1
635034	CLRND 5 161.0	560001	NODAWAYCO 161.0	1	153	146.3	146.5	3.8%	Intact	XS640131>640132>643039\$1
635034	CLRND 5 161.0	560001	NODAWAYCO 161.0	1	153	146.3	146.5	3.8%	Intact	XS636681>636682>\$1
635034	CLRND 5 161.0	560001	NODAWAYCO 161.0	1	153	146.3	146.5	3.8%	Intact	XS640228>640229>\$1
635034	CLRND 5 161.0	560001	NODAWAYCO 161.0	1	153	146.3	146.5	3.8%	Intact	XS640248>640250>\$1
635034	CLRND 5 161.0	560001	NODAWAYCO 161.0	1	153	146.3	146.5	3.8%	Intact	XS640183>640184>643066\$2
635034	CLRND 5 161.0	560001	NODAWAYCO 161.0	1	153	146.3	146.5	3.8%	Intact	XS640340>640341>\$1

635034	CLRND 5 161.0	560001	NODAWAYCO 161.0	1	153	146.3	146.5	3.8%	Intact	XS641087>641090>\$1
635034	CLRND 5 161.0	560001	NODAWAYCO 161.0	1	153	146.3	146.5	3.8%	Intact	XS640215>640216>\$2
635034	CLRND 5 161.0	560001	NODAWAYCO 161.0	1	153	146.3	146.5	3.8%	Intact	XS640206>640368>\$1
635034	CLRND 5 161.0	560001	NODAWAYCO 161.0	1	153	146.3	146.5	3.8%	Intact	XS640387>640424>\$1
635034	CLRND 5 161.0	560001	NODAWAYCO 161.0	1	153	146.3	146.5	3.8%	Intact	XS640248>640331>\$1
635034	CLRND 5 161.0	560001	NODAWAYCO 161.0	1	153	146.3	146.5	3.8%	Intact	XS640387>640388>\$2
635034	CLRND 5 161.0	560001	NODAWAYCO 161.0	1	153	146.3	146.5	3.8%	Intact	XS640387>640424>\$2
635034	CLRND 5 161.0	560001	NODAWAYCO 161.0	1	153	146.3	146.5	3.8%	Intact	XS640183>640184>640185\$1
635034	CLRND 5 161.0	560001	NODAWAYCO 161.0	1	153	146.3	146.5	3.8%	Intact	XS641083>641084>\$1
635034	CLRND 5 161.0	560001	NODAWAYCO 161.0	1	153	146.3	146.5	3.8%	Intact	XS640386>640387>643156\$2
635034	CLRND 5 161.0	560001	NODAWAYCO 161.0	1	153	146.3	146.5	3.8%	Intact	XS645032>647906>\$1
635034	CLRND 5 161.0	560001	NODAWAYCO 161.0	1	153	146.3	146.5	3.8%	Intact	XS640347>640348>643139\$1
635034	CLRND 5 161.0	560001	NODAWAYCO 161.0	1	153	146.3	146.5	3.8%	Intact	XS645031>647006>\$1
635034	CLRND 5 161.0	560001	NODAWAYCO 161.0	1	153	146.3	146.5	3.8%	Intact	XS640305>640306>\$2
635034	CLRND 5 161.0	560001	NODAWAYCO 161.0	1	153	146.3	146.5	3.8%	Intact	XS640224>640225>\$1
635034	CLRND 5 161.0	560001	NODAWAYCO 161.0	1	153	146.3	146.5	3.8%	Intact	XS640347>640348>643169\$2
635034	CLRND 5 161.0	560001	NODAWAYCO 161.0	1	153	146.3	146.5	3.8%	Intact	XS640305>640306>\$1
635034	CLRND 5 161.0	560001	NODAWAYCO 161.0	1	153	146.3	146.5	3.8%	Intact	XS640224>640225>\$2
635034	CLRND 5 161.0	560001	NODAWAYCO 161.0	1	153	146.3	146.5	3.8%	Intact	XS640261>640275>\$1
635034	CLRND 5 161.0	560001	NODAWAYCO 161.0	1	153	146.3	146.5	3.8%	Intact	XS640345>640346>\$2
635034	CLRND 5 161.0	560001	NODAWAYCO 161.0	1	153	146.3	146.5	3.8%	Intact	XS641083>641090>\$1
635034	CLRND 5 161.0	560001	NODAWAYCO 161.0	1	153	146.3	146.5	3.8%	Intact	XS640345>640346>\$1
635034	CLRND 5 161.0	560001	NODAWAYCO 161.0	1	153	146.3	146.5	3.8%	Intact	XS640275>640276>\$1
635034	CLRND 5 161.0	560001	NODAWAYCO 161.0	1	153	146.3	146.5	3.8%	Intact	XS640215>640216>\$1
635034	CLRND 5 161.0	560001	NODAWAYCO 161.0	1	153	146.3	146.5	3.8%	Intact	XS640340>640341>\$2

635034	CLRND 5 161.0	560001	NODAWAYCO 161.0	1	153	146.3	146.5	3.8%	Intact	XS640224>640242>\$1
635034	CLRND 5 161.0	560001	NODAWAYCO 161.0	1	153	146.3	146.5	3.8%	Intact	XS640282>641082>\$1
635034	CLRND 5 161.0	560001	NODAWAYCO 161.0	1	153	146.3	146.5	3.8%	Intact	XS645051>647901>\$1
635034	CLRND 5 161.0	560001	NODAWAYCO 161.0	1	153	146.3	146.5	3.8%	Intact	XS640275>640276>\$2
635034	CLRND 5 161.0	560001	NODAWAYCO 161.0	1	153	146.3	146.5	3.8%	Intact	XS640228>640229>\$2
635034	CLRND 5 161.0	560001	NODAWAYCO 161.0	1	153	146.3	146.5	3.8%	Intact	XS640250>640251>\$2
635034	CLRND 5 161.0	560001	NODAWAYCO 161.0	1	153	146.3	146.5	3.8%	Intact	XS640250>640251>\$1
635034	CLRND 5 161.0	560001	NODAWAYCO 161.0	1	153	146.3	146.5	3.8%	Intact	XS645052>647901>\$1
635034	CLRND 5 161.0	560001	NODAWAYCO 161.0	1	153	146.3	146.5	3.8%	Intact	XS640387>640388>\$1
635034	CLRND 5 161.0	560001	NODAWAYCO 161.0	1	153	146.3	146.5	3.8%	Intact	XS640278>640021>\$1
635034	CLRND 5 161.0	560001	NODAWAYCO 161.0	1	153	146.3	146.5	3.8%	Intact	XS640269>640270>\$2
635034	CLRND 5 161.0	560001	NODAWAYCO 161.0	1	153	146.3	146.5	3.8%	Intact	XS645115>646258>\$1
635034	CLRND 5 161.0	560001	NODAWAYCO 161.0	1	153	146.3	146.5	3.8%	Intact	XS642066>642064>\$1
635034	CLRND 5 161.0	560001	NODAWAYCO 161.0	1	153	146.3	146.5	3.8%	Intact	XS640269>640326>\$2
635034	CLRND 5 161.0	560001	NODAWAYCO 161.0	1	153	146.3	146.5	3.8%	Intact	XS642070>642072>\$1
635034	CLRND 5 161.0	560001	NODAWAYCO 161.0	1	153	146.3	146.5	3.8%	Intact	XS640298>640299>\$1
635034	CLRND 5 161.0	560001	NODAWAYCO 161.0	1	153	146.3	146.5	3.8%	Intact	XS645116>646258>\$1
635034	CLRND 5 161.0	560001	NODAWAYCO 161.0	1	153	146.3	146.5	3.8%	Intact	XS640215>641088>\$1
635034	CLRND 5 161.0	560001	NODAWAYCO 161.0	1	153	146.3	146.5	3.8%	Intact	XS642066>642065>\$1
635034	CLRND 5 161.0	560001	NODAWAYCO 161.0	1	153	146.3	146.5	3.8%	Intact	XS640181>640182>\$2
635034	CLRND 5 161.0	560001	NODAWAYCO 161.0	1	153	146.3	146.5	3.8%	Intact	XS641082>641084>\$1
635034	CLRND 5 161.0	560001	NODAWAYCO 161.0	1	153	146.3	146.5	3.8%	Intact	XS640238>640240>\$1
635034	CLRND 5 161.0	560001	NODAWAYCO 161.0	1	153	146.3	146.5	3.8%	Intact	XS640331>640383>\$1
635034	CLRND 5 161.0	560001	NODAWAYCO 161.0	1	153	146.3	146.5	3.8%	Intact	XS642070>642073>\$1
635034	CLRND 5 161.0	560001	NODAWAYCO 161.0	1	153	146.3	146.5	3.8%	Intact	XS640235>640361>\$1

635034	CLRND 5 161.0	560001	NODAWAYCO 161.0	1	153	146.3	146.5	3.8%	Intact	XS642069>642073>\$1
635034	CLRND 5 161.0	560001	NODAWAYCO 161.0	1	153	146.3	146.5	3.8%	Intact	XS642066>642071>\$1
635034	CLRND 5 161.0	560001	NODAWAYCO 161.0	1	153	146.3	146.5	3.8%	Intact	XS640252>640253>640254\$1
635034	CLRND 5 161.0	560001	NODAWAYCO 161.0	1	153	146.3	146.5	3.8%	Intact	XS640269>640017>\$1
635034	CLRND 5 161.0	560001	NODAWAYCO 161.0	1	153	146.3	146.5	3.8%	Intact	XS640215>641087>\$1
635034	CLRND 5 161.0	560001	NODAWAYCO 161.0	1	153	146.3	146.5	3.8%	Intact	XS642066>642075>\$1
635034	CLRND 5 161.0	560001	NODAWAYCO 161.0	1	153	146.3	146.5	3.8%	Intact	XS640296>640297>\$1
635034	CLRND 5 161.0	560001	NODAWAYCO 161.0	1	153	146.3	146.5	3.8%	Intact	XS642066>642074>\$1
635034	CLRND 5 161.0	560001	NODAWAYCO 161.0	1	153	146.3	146.5	3.8%	Intact	XS640181>640182>\$1
635034	CLRND 5 161.0	560001	NODAWAYCO 161.0	1	153	146.3	146.5	3.8%	Intact	XS640269>640270>\$1
635034	CLRND 5 161.0	560001	NODAWAYCO 161.0	1	153	146.3	146.5	3.8%	Intact	XS640296>640297>\$2
635034	CLRND 5 161.0	560001	NODAWAYCO 161.0	1	153	146.3	146.5	3.8%	Intact	XS642066>642072>\$1
635034	CLRND 5 161.0	560001	NODAWAYCO 161.0	1	153	146.3	146.5	3.8%	Intact	XS640250>640383>\$1
635034	CLRND 5 161.0	560001	NODAWAYCO 161.0	1	153	146.3	146.5	3.8%	Intact	XS640296>640298>\$1
635034	CLRND 5 161.0	560001	NODAWAYCO 161.0	1	153	146.3	146.5	3.8%	Intact	XS640336>640337>\$1
635034	CLRND 5 161.0	560001	NODAWAYCO 161.0	1	153	146.3	146.5	3.8%	Intact	XS640215>640313>\$1
635034	CLRND 5 161.0	560001	NODAWAYCO 161.0	1	153	146.3	146.5	3.8%	Intact	XS640298>640299>\$2
635034	CLRND 5 161.0	560001	NODAWAYCO 161.0	1	153	146.3	146.5	3.8%	Intact	XS640336>640337>\$2
635034	CLRND 5 161.0	560001	NODAWAYCO 161.0	1	153	146.3	146.5	3.8%	Intact	XS645114>646258>\$1
635034	CLRND 5 161.0	560001	NODAWAYCO 161.0	1	153	146.3	146.5	3.8%	Intact	XS640246>652300>\$1
635034	CLRND 5 161.0	560001	NODAWAYCO 161.0	1	153	146.3	146.5	3.8%	Intact	XS640218>640012>\$1
635034	CLRND 5 161.0	560001	NODAWAYCO 161.0	1	153	146.3	146.5	3.8%	Intact	XS640253>659132>\$1
635034	CLRND 5 161.0	560001	NODAWAYCO 161.0	1	153	146.3	146.5	3.8%	Intact	XS641082>641085>\$1
635034	CLRND 5 161.0	560001	NODAWAYCO 161.0	1	153	146.3	146.5	3.8%	Intact	XS645113>646258>\$1
635034	CLRND 5 161.0	560001	NODAWAYCO 161.0	1	153	146.3	146.5	3.8%	Intact	XS647912>647923>\$1

635034	CLRND 5 161.0	560001	NODAWAYCO 161.0	1	153	146.3	146.5	3.8%	Intact	XS647016>647107>\$1
635034	CLRND 5 161.0	560001	NODAWAYCO 161.0	1	153	146.3	146.5	3.8%	Intact	XS647994>647995>\$1
635034	CLRND 5 161.0	560001	NODAWAYCO 161.0	1	153	146.3	146.5	3.8%	Intact	XS647107>647994>\$1
635034	CLRND 5 161.0	560001	NODAWAYCO 161.0	1	153	146.3	146.5	3.8%	Intact	XS650256>650257>\$1
635034	CLRND 5 161.0	560001	NODAWAYCO 161.0	1	153	146.3	146.5	3.8%	Intact	XS647015>647017>\$1
635034	CLRND 5 161.0	560001	NODAWAYCO 161.0	1	153	146.3	146.5	3.8%	Intact	XS647105>647910>\$1
635034	CLRND 5 161.0	560001	NODAWAYCO 161.0	1	153	146.3	146.5	3.8%	Intact	XS646226>646298>\$1
635034	CLRND 5 161.0	560001	NODAWAYCO 161.0	1	153	146.3	146.5	3.8%	Intact	XS647938>647995>\$1
635034	CLRND 5 161.0	560001	NODAWAYCO 161.0	1	153	146.3	146.5	3.8%	Intact	XS650250>650255>\$1
635034	CLRND 5 161.0	560001	NODAWAYCO 161.0	1	153	146.3	146.5	3.8%	Intact	XS650219>650240>\$1
635034	CLRND 5 161.0	560001	NODAWAYCO 161.0	1	153	146.3	146.5	3.8%	Intact	XS647105>647901>\$1
635034	CLRND 5 161.0	560001	NODAWAYCO 161.0	1	153	146.3	146.5	3.8%	Intact	XS646226>646298>\$2
635034	CLRND 5 161.0	560001	NODAWAYCO 161.0	1	153	146.3	146.5	3.8%	Intact	XS650208>650308>\$2
635034	CLRND 5 161.0	560001	NODAWAYCO 161.0	1	153	146.3	146.5	3.8%	Intact	XS650242>650290>\$1
635034	CLRND 5 161.0	560001	NODAWAYCO 161.0	1	153	146.3	146.5	3.8%	Intact	XS650290>650091>\$1
635034	CLRND 5 161.0	560001	NODAWAYCO 161.0	1	153	146.3	146.5	3.8%	Intact	XS647411>647427>\$1
635034	CLRND 5 161.0	560001	NODAWAYCO 161.0	1	153	146.3	146.5	3.8%	Intact	XS650290>650093>\$1
635034	CLRND 5 161.0	560001	NODAWAYCO 161.0	1	153	146.3	146.5	3.8%	Intact	XS646236>646345>\$1
635034	CLRND 5 161.0	560001	NODAWAYCO 161.0	1	153	146.3	146.5	3.8%	Intact	XS647006>647017>\$1
635034	CLRND 5 161.0	560001	NODAWAYCO 161.0	1	153	146.3	146.5	3.8%	Intact	XS650230>650238>\$1
635034	CLRND 5 161.0	560001	NODAWAYCO 161.0	1	153	146.3	146.5	3.8%	Intact	XS647909>647921>\$1
635034	CLRND 5 161.0	560001	NODAWAYCO 161.0	1	153	146.3	146.5	3.8%	Intact	XS647102>647103>\$1
635034	CLRND 5 161.0	560001	NODAWAYCO 161.0	1	153	146.3	146.5	3.8%	Intact	XS650208>650308>\$3
635034	CLRND 5 161.0	560001	NODAWAYCO 161.0	1	153	146.3	146.5	3.8%	Intact	XS647918>647930>\$1
635034	CLRND 5 161.0	560001	NODAWAYCO 161.0	1	153	146.3	146.5	3.8%	Intact	XS650270>650271>\$1

635034	CLRND 5 161.0	560001	NODAWAYCO 161.0	1	153	146.3	146.5	3.8%	Intact	XS650185>650285>650385\$1
635034	CLRND 5 161.0	560001	NODAWAYCO 161.0	1	153	146.3	146.5	3.8%	Intact	XS647424>647425>\$1
635034	CLRND 5 161.0	560001	NODAWAYCO 161.0	1	153	146.3	146.5	3.8%	Intact	XS650217>650219>\$1
635034	CLRND 5 161.0	560001	NODAWAYCO 161.0	1	153	146.3	146.5	3.8%	Intact	XS650185>650285>650485\$2
635034	CLRND 5 161.0	560001	NODAWAYCO 161.0	1	153	146.3	146.5	3.8%	Intact	XS650214>650290>\$1
635034	CLRND 5 161.0	560001	NODAWAYCO 161.0	1	153	146.3	146.5	3.8%	Intact	XS650238>650258>\$1
635034	CLRND 5 161.0	560001	NODAWAYCO 161.0	1	153	146.3	146.5	3.8%	Intact	XS650267>650367>\$2
635034	CLRND 5 161.0	560001	NODAWAYCO 161.0	1	153	146.3	146.5	3.8%	Intact	XS646298>646305>\$1
635034	CLRND 5 161.0	560001	NODAWAYCO 161.0	1	153	146.3	146.5	3.8%	Intact	XS647017>647108>\$1
635034	CLRND 5 161.0	560001	NODAWAYCO 161.0	1	153	146.3	146.5	3.8%	Intact	XS646237>646253>\$1
635034	CLRND 5 161.0	560001	NODAWAYCO 161.0	1	153	146.3	146.5	3.8%	Intact	XS650267>650367>\$1
635034	CLRND 5 161.0	560001	NODAWAYCO 161.0	1	153	146.3	146.5	3.8%	Intact	XS650267>650285>\$1
635034	CLRND 5 161.0	560001	NODAWAYCO 161.0	1	153	146.3	146.5	3.8%	Intact	XS647114>647962>\$1
635034	CLRND 5 161.0	560001	NODAWAYCO 161.0	1	153	146.3	146.5	3.8%	Intact	XS647421>647426>\$1
635034	CLRND 5 161.0	560001	NODAWAYCO 161.0	1	153	146.3	146.5	3.8%	Intact	XS646251>646341>\$1
635034	CLRND 5 161.0	560001	NODAWAYCO 161.0	1	153	146.3	146.5	3.8%	Intact	XS646305>646341>\$1
635034	CLRND 5 161.0	560001	NODAWAYCO 161.0	1	153	146.3	146.5	3.8%	Intact	XS650218>650238>\$1
635034	CLRND 5 161.0	560001	NODAWAYCO 161.0	1	153	146.3	146.5	3.8%	Intact	XS647108>647994>\$1
635034	CLRND 5 161.0	560001	NODAWAYCO 161.0	1	153	146.3	146.5	3.8%	Intact	XS647016>647906>\$1
635034	CLRND 5 161.0	560001	NODAWAYCO 161.0	1	153	146.3	146.5	3.8%	Intact	XS650218>650230>\$1
635034	CLRND 5 161.0	560001	NODAWAYCO 161.0	1	153	146.3	146.5	3.8%	Intact	XS300067>300111>\$1
635034	CLRND 5 161.0	560001	NODAWAYCO 161.0	1	153	146.3	146.5	3.8%	Intact	XS300035>300046>\$2
635034	CLRND 5 161.0	560001	NODAWAYCO 161.0	1	153	146.3	146.5	3.8%	Intact	XS300077>344179>\$1
635034	CLRND 5 161.0	560001	NODAWAYCO 161.0	1	153	146.3	146.5	3.8%	Intact	XS300075>300029>\$1
635034	CLRND 5 161.0	560001	NODAWAYCO 161.0	1	153	146.3	146.5	3.8%	Intact	XS300093>301212>\$1

635034	CLRND 5 161.0	560001	NODAWAYCO 161.0	1	153	146.3	146.5	3.8%	Intact	XS300074>301149>\$1
635034	CLRND 5 161.0	560001	NODAWAYCO 161.0	1	153	146.3	146.5	3.8%	Intact	XS300084>301207>\$1
635034	CLRND 5 161.0	560001	NODAWAYCO 161.0	1	153	146.3	146.5	3.8%	Intact	XS300074>301136>\$1
635034	CLRND 5 161.0	560001	NODAWAYCO 161.0	1	153	146.3	146.5	3.8%	Intact	XS300057>344026>\$1
635034	CLRND 5 161.0	560001	NODAWAYCO 161.0	1	153	146.3	146.5	3.8%	Intact	XS300095>301128>\$1
635034	CLRND 5 161.0	560001	NODAWAYCO 161.0	1	153	146.3	146.5	3.8%	Intact	XS300089>300673>\$1
635034	CLRND 5 161.0	560001	NODAWAYCO 161.0	1	153	146.3	146.5	3.8%	Intact	XS300089>300348>\$1
635034	CLRND 5 161.0	560001	NODAWAYCO 161.0	1	153	146.3	146.5	3.8%	Intact	XS300064>301044>\$1
635034	CLRND 5 161.0	560001	NODAWAYCO 161.0	1	153	146.3	146.5	3.8%	Intact	XS300089>300673>\$2
635034	CLRND 5 161.0	560001	NODAWAYCO 161.0	1	153	146.3	146.5	3.8%	Intact	XS300070>300802>\$1
635034	CLRND 5 161.0	560001	NODAWAYCO 161.0	1	153	146.3	146.5	3.8%	Intact	XS300077>345511>\$1
635034	CLRND 5 161.0	560001	NODAWAYCO 161.0	1	153	146.3	146.5	3.8%	Intact	XS300053>345024>\$1
635034	CLRND 5 161.0	560001	NODAWAYCO 161.0	1	153	146.3	146.5	3.8%	Intact	XS300069>512648>\$1
635034	CLRND 5 161.0	560001	NODAWAYCO 161.0	1	153	146.3	146.5	3.8%	Intact	XS300099>300575>\$1
635034	CLRND 5 161.0	560001	NODAWAYCO 161.0	1	153	146.3	146.5	3.8%	Intact	XS300035>300046>\$1
635034	CLRND 5 161.0	560001	NODAWAYCO 161.0	1	153	146.3	146.5	3.8%	Intact	XS300089>300678>\$1
635034	CLRND 5 161.0	560001	NODAWAYCO 161.0	1	153	146.3	146.5	3.8%	Intact	XS300079>344586>\$1
635034	CLRND 5 161.0	560001	NODAWAYCO 161.0	1	153	146.3	146.5	3.8%	Intact	XS300077>344566>\$1
635034	CLRND 5 161.0	560001	NODAWAYCO 161.0	1	153	146.3	146.5	3.8%	Intact	XS300053>300096>\$1
635034	CLRND 5 161.0	560001	NODAWAYCO 161.0	1	153	146.3	146.5	3.8%	Intact	XS300138>300996>\$1
635034	CLRND 5 161.0	560001	NODAWAYCO 161.0	1	153	146.3	146.5	3.8%	Intact	XS300348>549954>\$1
635034	CLRND 5 161.0	560001	NODAWAYCO 161.0	1	153	146.3	146.5	3.8%	Intact	XS300123>505448>\$1
635034	CLRND 5 161.0	560001	NODAWAYCO 161.0	1	153	146.3	146.5	3.8%	Intact	XS300112>301027>\$2
635034	CLRND 5 161.0	560001	NODAWAYCO 161.0	1	153	146.3	146.5	3.8%	Intact	XS300104>300026>\$2
635034	CLRND 5 161.0	560001	NODAWAYCO 161.0	1	153	146.3	146.5	3.8%	Intact	XS300766>512655>\$1

635034	CLRND 5 161.0	560001	NODAWAYCO 161.0	1	153	146.3	146.5	3.8%	Intact	XS300112>301149>\$1
635034	CLRND 5 161.0	560001	NODAWAYCO 161.0	1	153	146.3	146.5	3.8%	Intact	XS300139>300929>\$1
635034	CLRND 5 161.0	560001	NODAWAYCO 161.0	1	153	146.3	146.5	3.8%	Intact	XS300104>300025>\$1
635034	CLRND 5 161.0	560001	NODAWAYCO 161.0	1	153	146.3	146.5	3.8%	Intact	XS300138>300927>\$1
635034	CLRND 5 161.0	560001	NODAWAYCO 161.0	1	153	146.3	146.5	3.8%	Intact	XS300113>300339>\$1
635034	CLRND 5 161.0	560001	NODAWAYCO 161.0	1	153	146.3	146.5	3.8%	Intact	XS300122>301114>\$2
635034	CLRND 5 161.0	560001	NODAWAYCO 161.0	1	153	146.3	146.5	3.8%	Intact	XS300597>345544>\$1
635034	CLRND 5 161.0	560001	NODAWAYCO 161.0	1	153	146.3	146.5	3.8%	Intact	XS300138>300140>\$1
635034	CLRND 5 161.0	560001	NODAWAYCO 161.0	1	153	146.3	146.5	3.8%	Intact	XS532926>532932>\$1
635034	CLRND 5 161.0	560001	NODAWAYCO 161.0	1	153	146.3	146.5	3.8%	Intact	XS300131>300140>\$1
635034	CLRND 5 161.0	560001	NODAWAYCO 161.0	1	153	146.3	146.5	3.8%	Intact	XS532926>532937>\$1
635034	CLRND 5 161.0	560001	NODAWAYCO 161.0	1	153	146.3	146.5	3.8%	Intact	XS300130>300805>\$1
635034	CLRND 5 161.0	560001	NODAWAYCO 161.0	1	153	146.3	146.5	3.8%	Intact	XS300593>345091>\$1
635034	CLRND 5 161.0	560001	NODAWAYCO 161.0	1	153	146.3	146.5	3.8%	Intact	XS532932>532934>\$1
635034	CLRND 5 161.0	560001	NODAWAYCO 161.0	1	153	146.3	146.5	3.8%	Intact	XS300137>521026>\$1
635034	CLRND 5 161.0	560001	NODAWAYCO 161.0	1	153	146.3	146.5	3.8%	Intact	XS300124>300012>\$1
635034	CLRND 5 161.0	560001	NODAWAYCO 161.0	1	153	146.3	146.5	3.8%	Intact	XS300844>512712>\$1
635034	CLRND 5 161.0	560001	NODAWAYCO 161.0	1	153	146.3	146.5	3.8%	Intact	XS300766>512704>\$1
635034	CLRND 5 161.0	560001	NODAWAYCO 161.0	1	153	146.3	146.5	3.8%	Intact	XS300111>300643>\$1
635034	CLRND 5 161.0	560001	NODAWAYCO 161.0	1	153	146.3	146.5	3.8%	Intact	XS300596>300612>\$1
635034	CLRND 5 161.0	560001	NODAWAYCO 161.0	1	153	146.3	146.5	3.8%	Intact	XS300124>300014>\$3
635034	CLRND 5 161.0	560001	NODAWAYCO 161.0	1	153	146.3	146.5	3.8%	Intact	XS300480>345091>\$1
635034	CLRND 5 161.0	560001	NODAWAYCO 161.0	1	153	146.3	146.5	3.8%	Intact	XS301347>301356>\$1
635034	CLRND 5 161.0	560001	NODAWAYCO 161.0	1	153	146.3	146.5	3.8%	Intact	XS300124>300013>\$2
635034	CLRND 5 161.0	560001	NODAWAYCO 161.0	1	153	146.3	146.5	3.8%	Intact	XS300103>505428>\$1

635034	CLRND 5 161.0	560001	NODAWAYCO 161.0	1	153	146.3	146.5	3.8%	Intact	XS300480>300597>\$1
635034	CLRND 5 161.0	560001	NODAWAYCO 161.0	1	153	146.3	146.5	3.8%	Intact	XS532796>533040>532829\$1
635034	CLRND 5 161.0	560001	NODAWAYCO 161.0	1	153	146.3	146.5	3.8%	Intact	XS300139>510377>\$1
635034	CLRND 5 161.0	560001	NODAWAYCO 161.0	1	153	146.3	146.5	3.8%	Intact	XS300141>300845>\$1
635034	CLRND 5 161.0	560001	NODAWAYCO 161.0	1	153	146.3	146.5	3.8%	Intact	XS300143>300850>\$1
635034	CLRND 5 161.0	560001	NODAWAYCO 161.0	1	153	146.3	146.5	3.8%	Intact	XS300141>300845>\$2
635034	CLRND 5 161.0	560001	NODAWAYCO 161.0	1	153	146.3	146.5	3.8%	Intact	XS532863>533305>532890\$1
635034	CLRND 5 161.0	560001	NODAWAYCO 161.0	1	153	146.3	146.5	3.8%	Intact	XS300996>301339>\$1
635034	CLRND 5 161.0	560001	NODAWAYCO 161.0	1	153	146.3	146.5	3.8%	Intact	XS532937>533021>532959\$1
635034	CLRND 5 161.0	560001	NODAWAYCO 161.0	1	153	146.3	146.5	3.8%	Intact	XS300168>300173>\$1
635034	CLRND 5 161.0	560001	NODAWAYCO 161.0	1	153	146.3	146.5	3.8%	Intact	XS300119>301136>\$1
635034	CLRND 5 161.0	560001	NODAWAYCO 161.0	1	153	146.3	146.5	3.8%	Intact	XS532791>532796>\$1
635034	CLRND 5 161.0	560001	NODAWAYCO 161.0	1	153	146.3	146.5	3.8%	Intact	XS300102>301163>\$2
635034	CLRND 5 161.0	560001	NODAWAYCO 161.0	1	153	146.3	146.5	3.8%	Intact	XS300143>300844>\$1
635034	CLRND 5 161.0	560001	NODAWAYCO 161.0	1	153	146.3	146.5	3.8%	Intact	XS532937>533021>532958\$1
635034	CLRND 5 161.0	560001	NODAWAYCO 161.0	1	153	146.3	146.5	3.8%	Intact	XS300102>301163>\$1
635034	CLRND 5 161.0	560001	NODAWAYCO 161.0	1	153	146.3	146.5	3.8%	Intact	XS300119>301152>\$2
635034	CLRND 5 161.0	560001	NODAWAYCO 161.0	1	153	146.3	146.5	3.8%	Intact	XS300119>301152>\$1
635034	CLRND 5 161.0	560001	NODAWAYCO 161.0	1	153	146.3	146.5	3.8%	Intact	XS300678>505492>\$1
635034	CLRND 5 161.0	560001	NODAWAYCO 161.0	1	153	146.3	146.5	3.8%	Intact	XS300122>301114>\$1
635034	CLRND 5 161.0	560001	NODAWAYCO 161.0	1	153	146.3	146.5	3.8%	Intact	XS300608>300609>\$1
635034	CLRND 5 161.0	560001	NODAWAYCO 161.0	1	153	146.3	146.5	3.8%	Intact	XS532861>533326>532888\$1
635034	CLRND 5 161.0	560001	NODAWAYCO 161.0	1	153	146.3	146.5	3.8%	Intact	XS300168>300173>\$2
635034	CLRND 5 161.0	560001	NODAWAYCO 161.0	1	153	146.3	146.5	3.8%	Intact	XS300121>345790>\$1
635034	CLRND 5 161.0	560001	NODAWAYCO 161.0	1	153	146.3	146.5	3.8%	Intact	XS300756>338804>\$1

635034	CLRND 5 161.0	560001	NODAWAYCO 161.0	1	153	146.3	146.5	3.8%	Intact	XS300756>338200>\$1
635034	CLRND 5 161.0	560001	NODAWAYCO 161.0	1	153	146.3	146.5	3.8%	Intact	S1221 AUTOV3
635034	CLRND 5 161.0	560001	NODAWAYCO 161.0	1	153	146.3	146.5	3.8%	Intact	XS301347>301356>\$2
635034	CLRND 5 161.0	560001	NODAWAYCO 161.0	1	153	146.3	146.5	3.8%	Intact	XS300606>344449>\$1
635034	CLRND 5 161.0	560001	NODAWAYCO 161.0	1	153	146.3	146.5	3.8%	Intact	XS533370>533376>\$1
635034	CLRND 5 161.0	560001	NODAWAYCO 161.0	1	153	146.3	146.5	3.8%	Intact	XS532986>533037>\$1
635034	CLRND 5 161.0	560001	NODAWAYCO 161.0	1	153	146.3	146.5	3.8%	Intact	XS533259>533266>\$1
635034	CLRND 5 161.0	560001	NODAWAYCO 161.0	1	153	146.3	146.5	3.8%	Intact	XS533335>533340>\$1
635034	CLRND 5 161.0	560001	NODAWAYCO 161.0	1	153	146.3	146.5	3.8%	Intact	XS533370>533371>\$2
635034	CLRND 5 161.0	560001	NODAWAYCO 161.0	1	153	146.3	146.5	3.8%	Intact	XS533040>532729>\$1
635034	CLRND 5 161.0	560001	NODAWAYCO 161.0	1	153	146.3	146.5	3.8%	Intact	XS533021>533768>533099\$1
635034	CLRND 5 161.0	560001	NODAWAYCO 161.0	1	153	146.3	146.5	3.8%	Intact	XS533335>533340>\$2
635034	CLRND 5 161.0	560001	NODAWAYCO 161.0	1	153	146.3	146.5	3.8%	Intact	XS533218>533220>\$1
635034	CLRND 5 161.0	560001	NODAWAYCO 161.0	1	153	146.3	146.5	3.8%	Intact	XS533361>533886>\$2
635034	CLRND 5 161.0	560001	NODAWAYCO 161.0	1	153	146.3	146.5	3.8%	Intact	XS533370>533371>\$1
635034	CLRND 5 161.0	560001	NODAWAYCO 161.0	1	153	146.3	146.5	3.8%	Intact	XS533151>533167>\$1
635034	CLRND 5 161.0	560001	NODAWAYCO 161.0	1	153	146.3	146.5	3.8%	Intact	XS533337>533348>\$1
635034	CLRND 5 161.0	560001	NODAWAYCO 161.0	1	153	146.3	146.5	3.8%	Intact	XS533029>533039>\$1
635034	CLRND 5 161.0	560001	NODAWAYCO 161.0	1	153	146.3	146.5	3.8%	Intact	XS533259>533268>\$1
635034	CLRND 5 161.0	560001	NODAWAYCO 161.0	1	153	146.3	146.5	3.8%	Intact	XS533021>533768>533100\$1
635034	CLRND 5 161.0	560001	NODAWAYCO 161.0	1	153	146.3	146.5	3.8%	Intact	XS533266>533272>\$1
635034	CLRND 5 161.0	560001	NODAWAYCO 161.0	1	153	146.3	146.5	3.8%	Intact	XS533176>533182>\$1
635034	CLRND 5 161.0	560001	NODAWAYCO 161.0	1	153	146.3	146.5	3.8%	Intact	XS532987>532991>\$1
635034	CLRND 5 161.0	560001	NODAWAYCO 161.0	1	153	146.3	146.5	3.8%	Intact	XS533328>533343>\$1
635034	CLRND 5 161.0	560001	NODAWAYCO 161.0	1	153	146.3	146.5	3.8%	Intact	XS533176>533195>\$1

635034	CLRND 5 161.0	560001	NODAWAYCO 161.0	1	153	146.3	146.5	3.8%	Intact	XS533232>533271>\$1
635034	CLRND 5 161.0	560001	NODAWAYCO 161.0	1	153	146.3	146.5	3.8%	Intact	XS533328>533343>\$2
635034	CLRND 5 161.0	560001	NODAWAYCO 161.0	1	153	146.3	146.5	3.8%	Intact	XS533153>533192>\$2
635034	CLRND 5 161.0	560001	NODAWAYCO 161.0	1	153	146.3	146.5	3.8%	Intact	XS533372>533373>\$1
635034	CLRND 5 161.0	560001	NODAWAYCO 161.0	1	153	146.3	146.5	3.8%	Intact	XS533333>533334>\$1
635034	CLRND 5 161.0	560001	NODAWAYCO 161.0	1	153	146.3	146.5	3.8%	Intact	XS533153>533192>\$1
635034	CLRND 5 161.0	560001	NODAWAYCO 161.0	1	153	146.3	146.5	3.8%	Intact	XS533178>533190>\$2
635034	CLRND 5 161.0	560001	NODAWAYCO 161.0	1	153	146.3	146.5	3.8%	Intact	XS533039>533068>\$1
635034	CLRND 5 161.0	560001	NODAWAYCO 161.0	1	153	146.3	146.5	3.8%	Intact	XS533178>533179>\$1
635034	CLRND 5 161.0	560001	NODAWAYCO 161.0	1	153	146.3	146.5	3.8%	Intact	XS533153>533182>\$1
635034	CLRND 5 161.0	560001	NODAWAYCO 161.0	1	153	146.3	146.5	3.8%	Intact	XS532987>532990>\$1
635034	CLRND 5 161.0	560001	NODAWAYCO 161.0	1	153	146.3	146.5	3.8%	Intact	XS533265>533273>\$1
635034	CLRND 5 161.0	560001	NODAWAYCO 161.0	1	153	146.3	146.5	3.8%	Intact	XS533178>533190>\$1
635034	CLRND 5 161.0	560001	NODAWAYCO 161.0	1	153	146.3	146.5	3.8%	Intact	XS533021>533768>532711\$1
635034	CLRND 5 161.0	560001	NODAWAYCO 161.0	1	153	146.3	146.5	3.8%	Intact	XS533370>533376>\$2
635034	CLRND 5 161.0	560001	NODAWAYCO 161.0	1	153	146.3	146.5	3.8%	Intact	XS533339>533340>\$2
635034	CLRND 5 161.0	560001	NODAWAYCO 161.0	1	153	146.3	146.5	3.8%	Intact	XS533011>533012>\$1
635034	CLRND 5 161.0	560001	NODAWAYCO 161.0	1	153	146.3	146.5	3.8%	Intact	XS533046>532739>\$1
635034	CLRND 5 161.0	560001	NODAWAYCO 161.0	1	153	146.3	146.5	3.8%	Intact	XS533248>533252>\$1
635034	CLRND 5 161.0	560001	NODAWAYCO 161.0	1	153	146.3	146.5	3.8%	Intact	XS533185>533186>\$1
635034	CLRND 5 161.0	560001	NODAWAYCO 161.0	1	153	146.3	146.5	3.8%	Intact	XS533048>533066>\$1
635034	CLRND 5 161.0	560001	NODAWAYCO 161.0	1	153	146.3	146.5	3.8%	Intact	XS533361>532681>\$1
635034	CLRND 5 161.0	560001	NODAWAYCO 161.0	1	153	146.3	146.5	3.8%	Intact	XS533046>533795>533106\$1
635034	CLRND 5 161.0	560001	NODAWAYCO 161.0	1	153	146.3	146.5	3.8%	Intact	XS533189>533190>\$1
635034	CLRND 5 161.0	560001	NODAWAYCO 161.0	1	153	146.3	146.5	3.8%	Intact	XS533028>533048>\$1

635034	CLRND 5 161.0	560001	NODAWAYCO 161.0	1	153	146.3	146.5	3.8%	Intact	XS533026>533060>\$1
635034	CLRND 5 161.0	560001	NODAWAYCO 161.0	1	153	146.3	146.5	3.8%	Intact	XS533180>533192>\$1
635034	CLRND 5 161.0	560001	NODAWAYCO 161.0	1	153	146.3	146.5	3.8%	Intact	XS533043>533064>\$1
635034	CLRND 5 161.0	560001	NODAWAYCO 161.0	1	153	146.3	146.5	3.8%	Intact	XS533024>533060>\$1
635034	CLRND 5 161.0	560001	NODAWAYCO 161.0	1	153	146.3	146.5	3.8%	Intact	XS533361>533365>\$2
635034	CLRND 5 161.0	560001	NODAWAYCO 161.0	1	153	146.3	146.5	3.8%	Intact	XS533211>533216>\$1
635034	CLRND 5 161.0	560001	NODAWAYCO 161.0	1	153	146.3	146.5	3.8%	Intact	XS533045>533072>\$1
635034	CLRND 5 161.0	560001	NODAWAYCO 161.0	1	153	146.3	146.5	3.8%	Intact	XS533044>533045>\$1
635034	CLRND 5 161.0	560001	NODAWAYCO 161.0	1	153	146.3	146.5	3.8%	Intact	XS533361>533371>\$1
635034	CLRND 5 161.0	560001	NODAWAYCO 161.0	1	153	146.3	146.5	3.8%	Intact	XS533045>533046>\$1
635034	CLRND 5 161.0	560001	NODAWAYCO 161.0	1	153	146.3	146.5	3.8%	Intact	XS533361>533371>\$2
635034	CLRND 5 161.0	560001	NODAWAYCO 161.0	1	153	146.3	146.5	3.8%	Intact	XS533250>533253>\$1
635034	CLRND 5 161.0	560001	NODAWAYCO 161.0	1	153	146.3	146.5	3.8%	Intact	XS533361>533365>\$1
635034	CLRND 5 161.0	560001	NODAWAYCO 161.0	1	153	146.3	146.5	3.8%	Intact	XS533041>532724>\$1
635034	CLRND 5 161.0	560001	NODAWAYCO 161.0	1	153	146.3	146.5	3.8%	Intact	XS533175>533185>\$1
635034	CLRND 5 161.0	560001	NODAWAYCO 161.0	1	153	146.3	146.5	3.8%	Intact	XS533257>533280>\$1
635034	CLRND 5 161.0	560001	NODAWAYCO 161.0	1	153	146.3	146.5	3.8%	Intact	XS533029>533046>\$1
635034	CLRND 5 161.0	560001	NODAWAYCO 161.0	1	153	146.3	146.5	3.8%	Intact	XS532986>533024>\$1
635034	CLRND 5 161.0	560001	NODAWAYCO 161.0	1	153	146.3	146.5	3.8%	Intact	XS533041>532723>\$1
635034	CLRND 5 161.0	560001	NODAWAYCO 161.0	1	153	146.3	146.5	3.8%	Intact	XS533257>533271>\$1
635034	CLRND 5 161.0	560001	NODAWAYCO 161.0	1	153	146.3	146.5	3.8%	Intact	XS533060>533822>533111\$1
635034	CLRND 5 161.0	560001	NODAWAYCO 161.0	1	153	146.3	146.5	3.8%	Intact	XS533021>533768>533100\$2
635034	CLRND 5 161.0	560001	NODAWAYCO 161.0	1	153	146.3	146.5	3.8%	Intact	XS533364>533376>\$1
635034	CLRND 5 161.0	560001	NODAWAYCO 161.0	1	153	146.3	146.5	3.8%	Intact	XS533255>533273>\$1
635034	CLRND 5 161.0	560001	NODAWAYCO 161.0	1	153	146.3	146.5	3.8%	Intact	XS533049>533051>\$1

635034	CLRND 5 161.0	560001	NODAWAYCO 161.0	1	153	146.3	146.5	3.8%	Intact	XS533004>533698>533091\$1
635034	CLRND 5 161.0	560001	NODAWAYCO 161.0	1	153	146.3	146.5	3.8%	Intact	XS533049>533805>533109\$1
635034	CLRND 5 161.0	560001	NODAWAYCO 161.0	1	153	146.3	146.5	3.8%	Intact	XS532986>532990>\$1
635034	CLRND 5 161.0	560001	NODAWAYCO 161.0	1	153	146.3	146.5	3.8%	Intact	XS532992>533558>533120\$1
635034	CLRND 5 161.0	560001	NODAWAYCO 161.0	1	153	146.3	146.5	3.8%	Intact	XS533248>533250>\$1
635034	CLRND 5 161.0	560001	NODAWAYCO 161.0	1	153	146.3	146.5	3.8%	Intact	XS533041>533053>\$1
635034	CLRND 5 161.0	560001	NODAWAYCO 161.0	1	153	146.3	146.5	3.8%	Intact	XS533216>533475>533450\$1
635034	CLRND 5 161.0	560001	NODAWAYCO 161.0	1	153	146.3	146.5	3.8%	Intact	XS533159>533184>\$1
635034	CLRND 5 161.0	560001	NODAWAYCO 161.0	1	153	146.3	146.5	3.8%	Intact	XS533339>533340>\$1
635034	CLRND 5 161.0	560001	NODAWAYCO 161.0	1	153	146.3	146.5	3.8%	Intact	XS533060>533822>533110\$1
635034	CLRND 5 161.0	560001	NODAWAYCO 161.0	1	153	146.3	146.5	3.8%	Intact	XS533172>533184>\$1
635034	CLRND 5 161.0	560001	NODAWAYCO 161.0	1	153	146.3	146.5	3.8%	Intact	XS533159>533174>\$1
635034	CLRND 5 161.0	560001	NODAWAYCO 161.0	1	153	146.3	146.5	3.8%	Intact	XS533162>533166>\$1
635034	CLRND 5 161.0	560001	NODAWAYCO 161.0	1	153	146.3	146.5	3.8%	Intact	XS533002>533003>\$1
635034	CLRND 5 161.0	560001	NODAWAYCO 161.0	1	153	146.3	146.5	3.8%	Intact	XS533172>533186>\$1
635034	CLRND 5 161.0	560001	NODAWAYCO 161.0	1	153	146.3	146.5	3.8%	Intact	XS533321>533342>\$1
635034	CLRND 5 161.0	560001	NODAWAYCO 161.0	1	153	146.3	146.5	3.8%	Intact	XS533375>533379>\$2
635034	CLRND 5 161.0	560001	NODAWAYCO 161.0	1	153	146.3	146.5	3.8%	Intact	XS532991>533026>\$1
635034	CLRND 5 161.0	560001	NODAWAYCO 161.0	1	153	146.3	146.5	3.8%	Intact	XS533220>533484>533451\$1
635034	CLRND 5 161.0	560001	NODAWAYCO 161.0	1	153	146.3	146.5	3.8%	Intact	XS533278>533283>\$1
635034	CLRND 5 161.0	560001	NODAWAYCO 161.0	1	153	146.3	146.5	3.8%	Intact	XS533037>533060>\$1
635034	CLRND 5 161.0	560001	NODAWAYCO 161.0	1	153	146.3	146.5	3.8%	Intact	XS532987>533001>\$1
635034	CLRND 5 161.0	560001	NODAWAYCO 161.0	1	153	146.3	146.5	3.8%	Intact	XS533160>533189>\$2
635034	CLRND 5 161.0	560001	NODAWAYCO 161.0	1	153	146.3	146.5	3.8%	Intact	XS533013>533429>533096\$1
635034	CLRND 5 161.0	560001	NODAWAYCO 161.0	1	153	146.3	146.5	3.8%	Intact	XS533323>533362>\$1

635034	CLRND 5 161.0	560001	NODAWAYCO 161.0	1	153	146.3	146.5	3.8%	Intact	XS533310>533311>\$1
635034	CLRND 5 161.0	560001	NODAWAYCO 161.0	1	153	146.3	146.5	3.8%	Intact	XS533012>533736>533092\$1
635034	CLRND 5 161.0	560001	NODAWAYCO 161.0	1	153	146.3	146.5	3.8%	Intact	XS533234>533241>\$1
635034	CLRND 5 161.0	560001	NODAWAYCO 161.0	1	153	146.3	146.5	3.8%	Intact	XS533167>533339>\$1
635034	CLRND 5 161.0	560001	NODAWAYCO 161.0	1	153	146.3	146.5	3.8%	Intact	XS533375>533379>\$1
635034	CLRND 5 161.0	560001	NODAWAYCO 161.0	1	153	146.3	146.5	3.8%	Intact	XS532987>533583>\$1
635034	CLRND 5 161.0	560001	NODAWAYCO 161.0	1	153	146.3	146.5	3.8%	Intact	XS533011>533736>533093\$1
635034	CLRND 5 161.0	560001	NODAWAYCO 161.0	1	153	146.3	146.5	3.8%	Intact	XS532987>533583>533118\$1
635034	CLRND 5 161.0	560001	NODAWAYCO 161.0	1	153	146.3	146.5	3.8%	Intact	XS533378>533379>\$2
635034	CLRND 5 161.0	560001	NODAWAYCO 161.0	1	153	146.3	146.5	3.8%	Intact	XS533160>533189>\$1
635034	CLRND 5 161.0	560001	NODAWAYCO 161.0	1	153	146.3	146.5	3.8%	Intact	XS533033>533043>\$1
635034	CLRND 5 161.0	560001	NODAWAYCO 161.0	1	153	146.3	146.5	3.8%	Intact	XS533035>533064>\$1
635034	CLRND 5 161.0	560001	NODAWAYCO 161.0	1	153	146.3	146.5	3.8%	Intact	XS533158>533173>\$1
635034	CLRND 5 161.0	560001	NODAWAYCO 161.0	1	153	146.3	146.5	3.8%	Intact	XS533032>533039>\$1
635034	CLRND 5 161.0	560001	NODAWAYCO 161.0	1	153	146.3	146.5	3.8%	Intact	XS533011>533013>\$1
635034	CLRND 5 161.0	560001	NODAWAYCO 161.0	1	153	146.3	146.5	3.8%	Intact	XS533158>533195>\$1
635034	CLRND 5 161.0	560001	NODAWAYCO 161.0	1	153	146.3	146.5	3.8%	Intact	XS533305>533309>\$1
635034	CLRND 5 161.0	560001	NODAWAYCO 161.0	1	153	146.3	146.5	3.8%	Intact	XS533373>533378>\$2
635034	CLRND 5 161.0	560001	NODAWAYCO 161.0	1	153	146.3	146.5	3.8%	Intact	XS533174>533461>533447\$1
635034	CLRND 5 161.0	560001	NODAWAYCO 161.0	1	153	146.3	146.5	3.8%	Intact	XS533234>533252>\$1
635034	CLRND 5 161.0	560001	NODAWAYCO 161.0	1	153	146.3	146.5	3.8%	Intact	XS533035>533054>\$1
635034	CLRND 5 161.0	560001	NODAWAYCO 161.0	1	153	146.3	146.5	3.8%	Intact	XS533162>533168>\$1
635034	CLRND 5 161.0	560001	NODAWAYCO 161.0	1	153	146.3	146.5	3.8%	Intact	XS533239>533255>\$1
635034	CLRND 5 161.0	560001	NODAWAYCO 161.0	1	153	146.3	146.5	3.8%	Intact	XS533373>533378>\$1
635034	CLRND 5 161.0	560001	NODAWAYCO 161.0	1	153	146.3	146.5	3.8%	Intact	XS533301>533309>\$1

635034	CLRND 5 161.0	560001	NODAWAYCO 161.0	1	153	146.3	146.5	3.8%	Intact	XS533273>533283>\$1
635034	CLRND 5 161.0	560001	NODAWAYCO 161.0	1	153	146.3	146.5	3.8%	Intact	XS533378>533379>\$1
635034	CLRND 5 161.0	560001	NODAWAYCO 161.0	1	153	146.3	146.5	3.8%	Intact	XS533242>533246>\$1
635034	CLRND 5 161.0	560001	NODAWAYCO 161.0	1	153	146.3	146.5	3.8%	Intact	XS533239>533278>\$1
635034	CLRND 5 161.0	560001	NODAWAYCO 161.0	1	153	146.3	146.5	3.8%	Intact	XS533159>533168>\$1
635034	CLRND 5 161.0	560001	NODAWAYCO 161.0	1	153	146.3	146.5	3.8%	Intact	XS532991>533032>\$1
635034	CLRND 5 161.0	560001	NODAWAYCO 161.0	1	153	146.3	146.5	3.8%	Intact	XS533171>533173>\$1
635034	CLRND 5 161.0	560001	NODAWAYCO 161.0	1	153	146.3	146.5	3.8%	Intact	XS652482>652264>\$1
635034	CLRND 5 161.0	560001	NODAWAYCO 161.0	1	153	146.3	146.5	3.8%	Intact	XS652530>652531>652240\$1
635034	CLRND 5 161.0	560001	NODAWAYCO 161.0	1	153	146.3	146.5	3.8%	Intact	XS652537>601031>\$2
635034	CLRND 5 161.0	560001	NODAWAYCO 161.0	1	153	146.3	146.5	3.8%	Intact	XS659244>659245>\$1
635034	CLRND 5 161.0	560001	NODAWAYCO 161.0	1	153	146.3	146.5	3.8%	Intact	XS652550>602007>\$1
635034	CLRND 5 161.0	560001	NODAWAYCO 161.0	1	153	146.3	146.5	3.8%	Intact	XS659195>659245>\$1
635034	CLRND 5 161.0	560001	NODAWAYCO 161.0	1	153	146.3	146.5	3.8%	Intact	XS652550>652551>652292\$1
635034	CLRND 5 161.0	560001	NODAWAYCO 161.0	1	153	146.3	146.5	3.8%	Intact	XS652530>652539>\$1
635034	CLRND 5 161.0	560001	NODAWAYCO 161.0	1	153	146.3	146.5	3.8%	Intact	XS652501>652510>\$1
635034	CLRND 5 161.0	560001	NODAWAYCO 161.0	1	153	146.3	146.5	3.8%	Intact	XS652513>652279>\$1
635034	CLRND 5 161.0	560001	NODAWAYCO 161.0	1	153	146.3	146.5	3.8%	Intact	XS652514>652515>652282\$2
635034	CLRND 5 161.0	560001	NODAWAYCO 161.0	1	153	146.3	146.5	3.8%	Intact	XS652537>601031>\$1
635034	CLRND 5 161.0	560001	NODAWAYCO 161.0	1	153	146.3	146.5	3.8%	Intact	XS652522>652326>\$1
635034	CLRND 5 161.0	560001	NODAWAYCO 161.0	1	153	146.3	146.5	3.8%	Intact	XS652507>652276>\$2
635034	CLRND 5 161.0	560001	NODAWAYCO 161.0	1	153	146.3	146.5	3.8%	Intact	XS652398>652399>\$1
635034	CLRND 5 161.0	560001	NODAWAYCO 161.0	1	153	146.3	146.5	3.8%	Intact	XS652523>652524>652233\$1
635034	CLRND 5 161.0	560001	NODAWAYCO 161.0	1	153	146.3	146.5	3.8%	Intact	XS659152>652479>\$1
635034	CLRND 5 161.0	560001	NODAWAYCO 161.0	1	153	146.3	146.5	3.8%	Intact	XS652550>619975>\$1

635034	CLRND 5 161.0	560001	NODAWAYCO 161.0	1	153	146.3	146.5	3.8%	Intact	XS652511>660006>\$1
635034	CLRND 5 161.0	560001	NODAWAYCO 161.0	1	153	146.3	146.5	3.8%	Intact	XS652512>652250>\$1
635034	CLRND 5 161.0	560001	NODAWAYCO 161.0	1	153	146.3	146.5	3.8%	Intact	XS652512>652250>\$2
635034	CLRND 5 161.0	560001	NODAWAYCO 161.0	1	153	146.3	146.5	3.8%	Intact	XS652550>652551>652297\$1
635034	CLRND 5 161.0	560001	NODAWAYCO 161.0	1	153	146.3	146.5	3.8%	Intact	XS652528>659123>\$1
635034	CLRND 5 161.0	560001	NODAWAYCO 161.0	1	153	146.3	146.5	3.8%	Intact	XS652512>652533>\$1
635034	CLRND 5 161.0	560001	NODAWAYCO 161.0	1	153	146.3	146.5	3.8%	Intact	XS652522>652531>\$1
635034	CLRND 5 161.0	560001	NODAWAYCO 161.0	1	153	146.3	146.5	3.8%	Intact	XS652512>652535>\$1
635034	CLRND 5 161.0	560001	NODAWAYCO 161.0	1	153	146.3	146.5	3.8%	Intact	XS652507>652276>\$1
635034	CLRND 5 161.0	560001	NODAWAYCO 161.0	1	153	146.3	146.5	3.8%	Intact	XS652500>652504>\$1
635034	CLRND 5 161.0	560001	NODAWAYCO 161.0	1	153	146.3	146.5	3.8%	Intact	XS652523>652524>652232\$1
635034	CLRND 5 161.0	560001	NODAWAYCO 161.0	1	153	146.3	146.5	3.8%	Intact	XS652501>652518>\$1
635034	CLRND 5 161.0	560001	NODAWAYCO 161.0	1	153	146.3	146.5	3.8%	Intact	XS652513>652278>\$1
635034	CLRND 5 161.0	560001	NODAWAYCO 161.0	1	153	146.3	146.5	3.8%	Intact	XS652530>652531>652239\$1
635034	CLRND 5 161.0	560001	NODAWAYCO 161.0	1	153	146.3	146.5	3.8%	Intact	XS652514>652515>652281\$1
635034	CLRND 5 161.0	560001	NODAWAYCO 161.0	1	153	146.3	146.5	3.8%	Intact	XS659193>659239>\$1
635034	CLRND 5 161.0	560001	NODAWAYCO 161.0	1	153	146.3	146.5	3.8%	Intact	XS652515>652535>\$1
635034	CLRND 5 161.0	560001	NODAWAYCO 161.0	1	153	146.3	146.5	3.8%	Intact	XS659185>659186>\$1
635034	CLRND 5 161.0	560001	NODAWAYCO 161.0	1	153	146.3	146.5	3.8%	Intact	XS652501>652249>\$1
635034	CLRND 5 161.0	560001	NODAWAYCO 161.0	1	153	146.3	146.5	3.8%	Intact	XS652532>652288>\$1
635034	CLRND 5 161.0	560001	NODAWAYCO 161.0	1	153	146.3	146.5	3.8%	Intact	XS652519>652520>\$1
635034	CLRND 5 161.0	560001	NODAWAYCO 161.0	1	153	146.3	146.5	3.8%	Intact	XS652531>658088>\$1
635034	CLRND 5 161.0	560001	NODAWAYCO 161.0	1	153	146.3	146.5	3.8%	Intact	XS652518>652252>\$1
635034	CLRND 5 161.0	560001	NODAWAYCO 161.0	1	153	146.3	146.5	3.8%	Intact	XS652515>660009>\$1
635034	CLRND 5 161.0	560001	NODAWAYCO 161.0	1	153	146.3	146.5	3.8%	Intact	XS652582>652604>652605\$1

635034	CLRND 5 161.0	560001	NODAWAYCO 161.0	1	153	146.3	146.5	3.8%	Intact	XS652570>659236>\$1
635034	CLRND 5 161.0	560001	NODAWAYCO 161.0	1	153	146.3	146.5	3.8%	Intact	XS652507>652514>\$2
635034	CLRND 5 161.0	560001	NODAWAYCO 161.0	1	153	146.3	146.5	3.8%	Intact	XS652501>652249>\$2
635034	CLRND 5 161.0	560001	NODAWAYCO 161.0	1	153	146.3	146.5	3.8%	Intact	XS652507>652514>\$1
635034	CLRND 5 161.0	560001	NODAWAYCO 161.0	1	153	146.3	146.5	3.8%	Intact	XS652531>658094>\$1
635034	CLRND 5 161.0	560001	NODAWAYCO 161.0	1	153	146.3	146.5	3.8%	Intact	XS652515>660003>\$1
635034	CLRND 5 161.0	560001	NODAWAYCO 161.0	1	153	146.3	146.5	3.8%	Intact	LES0006
635034	CLRND 5 161.0	560001	NODAWAYCO 161.0	1	153	146.3	146.5	3.8%	Intact	CB1298-05&26
635034	CLRND 5 161.0	560001	NODAWAYCO 161.0	1	153	146.3	146.5	3.8%	Intact	LN-1175B
635034	CLRND 5 161.0	560001	NODAWAYCO 161.0	1	153	146.3	146.5	3.8%	Intact	LES9002
635034	CLRND 5 161.0	560001	NODAWAYCO 161.0	1	153	146.3	146.5	3.8%	Intact	LES9003
635034	CLRND 5 161.0	560001	NODAWAYCO 161.0	1	153	146.3	146.5	3.8%	Intact	CB994-BUS
635034	CLRND 5 161.0	560001	NODAWAYCO 161.0	1	153	146.3	146.5	3.8%	Intact	LES7001
635034	CLRND 5 161.0	560001	NODAWAYCO 161.0	1	153	146.3	146.5	3.8%	Intact	D-CIRCUIT#8B
635034	CLRND 5 161.0	560001	NODAWAYCO 161.0	1	153	146.3	146.5	3.8%	Intact	901-JCT-910
635034	CLRND 5 161.0	560001	NODAWAYCO 161.0	1	153	146.3	146.5	3.8%	Intact	XS542988>542990>\$1
635034	CLRND 5 161.0	560001	NODAWAYCO 161.0	1	153	146.3	146.5	3.8%	Intact	XS542988>542989>\$2
635034	CLRND 5 161.0	560001	NODAWAYCO 161.0	1	153	146.3	146.5	3.8%	Intact	XS541209>300082>\$1
635034	CLRND 5 161.0	560001	NODAWAYCO 161.0	1	153	146.3	146.5	3.8%	Intact	XS542973>543011>\$1
635034	CLRND 5 161.0	560001	NODAWAYCO 161.0	1	153	146.3	146.5	3.8%	Intact	XS533435>533441>\$2
635034	CLRND 5 161.0	560001	NODAWAYCO 161.0	1	153	146.3	146.5	3.8%	Intact	XS533435>533441>\$1
635034	CLRND 5 161.0	560001	NODAWAYCO 161.0	1	153	146.3	146.5	3.8%	Intact	XS533428>533438>\$1
635034	CLRND 5 161.0	560001	NODAWAYCO 161.0	1	153	146.3	146.5	3.8%	Intact	XS542985>542975>542974\$1
635034	CLRND 5 161.0	560001	NODAWAYCO 161.0	1	153	146.3	146.5	3.8%	Intact	XS533428>532704>\$1
635034	CLRND 5 161.0	560001	NODAWAYCO 161.0	1	153	146.3	146.5	3.8%	Intact	XS533428>532703>\$1

635034	CLRND 5 161.0	560001	NODAWAYCO 161.0	1	153	146.3	146.5	3.8%	Intact	XS542973>543000>\$1
635034	CLRND 5 161.0	560001	NODAWAYCO 161.0	1	153	146.3	146.5	3.8%	Intact	XS533428>532702>\$1
635034	CLRND 5 161.0	560001	NODAWAYCO 161.0	1	153	146.3	146.5	3.8%	Intact	XS541242>541303>\$2
635034	CLRND 5 161.0	560001	NODAWAYCO 161.0	1	153	146.3	146.5	3.8%	Intact	XS542969>541341>\$1
635034	CLRND 5 161.0	560001	NODAWAYCO 161.0	1	153	146.3	146.5	3.8%	Intact	XS542993>543008>\$1
635034	CLRND 5 161.0	560001	NODAWAYCO 161.0	1	153	146.3	146.5	3.8%	Intact	XS533426>533438>\$1
635034	CLRND 5 161.0	560001	NODAWAYCO 161.0	1	153	146.3	146.5	3.8%	Intact	XS542973>543000>\$2
635034	CLRND 5 161.0	560001	NODAWAYCO 161.0	1	153	146.3	146.5	3.8%	Intact	XS542973>543080>\$12
635034	CLRND 5 161.0	560001	NODAWAYCO 161.0	1	153	146.3	146.5	3.8%	Intact	XS533416>533438>\$1
635034	CLRND 5 161.0	560001	NODAWAYCO 161.0	1	153	146.3	146.5	3.8%	Intact	XS533414>533415>\$1
635034	CLRND 5 161.0	560001	NODAWAYCO 161.0	1	153	146.3	146.5	3.8%	Intact	XS541224>541282>\$1
635034	CLRND 5 161.0	560001	NODAWAYCO 161.0	1	153	146.3	146.5	3.8%	Intact	XS542987>542989>\$1
635034	CLRND 5 161.0	560001	NODAWAYCO 161.0	1	153	146.3	146.5	3.8%	Intact	XS541219>541220>\$1
635034	CLRND 5 161.0	560001	NODAWAYCO 161.0	1	153	146.3	146.5	3.8%	Intact	XS542965>542968>\$1
635034	CLRND 5 161.0	560001	NODAWAYCO 161.0	1	153	146.3	146.5	3.8%	Intact	XS543020>543023>\$1
635034	CLRND 5 161.0	560001	NODAWAYCO 161.0	1	153	146.3	146.5	3.8%	Intact	XS541341>541167>\$1
635034	CLRND 5 161.0	560001	NODAWAYCO 161.0	1	153	146.3	146.5	3.8%	Intact	XS543032>543047>\$1
635034	CLRND 5 161.0	560001	NODAWAYCO 161.0	1	153	146.3	146.5	3.8%	Intact	XS543020>541248>\$1
635034	CLRND 5 161.0	560001	NODAWAYCO 161.0	1	153	146.3	146.5	3.8%	Intact	XS542976>542985>\$1
635034	CLRND 5 161.0	560001	NODAWAYCO 161.0	1	153	146.3	146.5	3.8%	Intact	XS542987>543636>\$1
635034	CLRND 5 161.0	560001	NODAWAYCO 161.0	1	153	146.3	146.5	3.8%	Intact	XS542966>543105>\$1
635034	CLRND 5 161.0	560001	NODAWAYCO 161.0	1	153	146.3	146.5	3.8%	Intact	XS533441>533455>\$2
635034	CLRND 5 161.0	560001	NODAWAYCO 161.0	1	153	146.3	146.5	3.8%	Intact	XS541250>541263>\$1
635034	CLRND 5 161.0	560001	NODAWAYCO 161.0	1	153	146.3	146.5	3.8%	Intact	XS533441>533455>\$1
635034	CLRND 5 161.0	560001	NODAWAYCO 161.0	1	153	146.3	146.5	3.8%	Intact	XS543034>543047>\$1

635034	CLRND 5 161.0	560001	NODAWAYCO 161.0	1	153	146.3	146.5	3.8%	Intact	XS541250>541263>\$2
635034	CLRND 5 161.0	560001	NODAWAYCO 161.0	1	153	146.3	146.5	3.8%	Intact	XS542988>542989>\$1
635034	CLRND 5 161.0	560001	NODAWAYCO 161.0	1	153	146.3	146.5	3.8%	Intact	XS533439>530620>\$1
635034	CLRND 5 161.0	560001	NODAWAYCO 161.0	1	153	146.3	146.5	3.8%	Intact	XS533438>533439>\$1
635034	CLRND 5 161.0	560001	NODAWAYCO 161.0	1	153	146.3	146.5	3.8%	Intact	XS542985>543011>\$1
635034	CLRND 5 161.0	560001	NODAWAYCO 161.0	1	153	146.3	146.5	3.8%	Intact	XS541225>541280>\$1
635034	CLRND 5 161.0	560001	NODAWAYCO 161.0	1	153	146.3	146.5	3.8%	Intact	XS541200>541225>541361\$1
635034	CLRND 5 161.0	560001	NODAWAYCO 161.0	1	153	146.3	146.5	3.8%	Intact	XS542985>542984>542983\$1
635034	CLRND 5 161.0	560001	NODAWAYCO 161.0	1	153	146.3	146.5	3.8%	Intact	XS533421>532698>\$1
635034	CLRND 5 161.0	560001	NODAWAYCO 161.0	1	153	146.3	146.5	3.8%	Intact	XS542973>542976>\$1
635034	CLRND 5 161.0	560001	NODAWAYCO 161.0	1	153	146.3	146.5	3.8%	Intact	XS541341>541343>\$1
635034	CLRND 5 161.0	560001	NODAWAYCO 161.0	1	153	146.3	146.5	3.8%	Intact	XS541210>541287>\$1
635034	CLRND 5 161.0	560001	NODAWAYCO 161.0	1	153	146.3	146.5	3.8%	Intact	XS533421>532697>\$1
635034	CLRND 5 161.0	560001	NODAWAYCO 161.0	1	153	146.3	146.5	3.8%	Intact	XS533421>532696>\$1
635034	CLRND 5 161.0	560001	NODAWAYCO 161.0	1	153	146.3	146.5	3.8%	Intact	XS533426>532705>\$1
635034	CLRND 5 161.0	560001	NODAWAYCO 161.0	1	153	146.3	146.5	3.8%	Intact	XS541341>541165>\$1
635034	CLRND 5 161.0	560001	NODAWAYCO 161.0	1	153	146.3	146.5	3.8%	Intact	XS543004>548808>\$1
635034	CLRND 5 161.0	560001	NODAWAYCO 161.0	1	153	146.3	146.5	3.8%	Intact	XS542985>542959>542958\$1
635034	CLRND 5 161.0	560001	NODAWAYCO 161.0	1	153	146.3	146.5	3.8%	Intact	XS543004>548807>\$1
635034	CLRND 5 161.0	560001	NODAWAYCO 161.0	1	153	146.3	146.5	3.8%	Intact	XS533413>533421>\$1
635034	CLRND 5 161.0	560001	NODAWAYCO 161.0	1	153	146.3	146.5	3.8%	Intact	XS542985>542971>542970\$1
635034	CLRND 5 161.0	560001	NODAWAYCO 161.0	1	153	146.3	146.5	3.8%	Intact	XS542992>542993>\$1
635034	CLRND 5 161.0	560001	NODAWAYCO 161.0	1	153	146.3	146.5	3.8%	Intact	XS542972>542973>543644\$20
635034	CLRND 5 161.0	560001	NODAWAYCO 161.0	1	153	146.3	146.5	3.8%	Intact	XS541341>541166>\$1
635034	CLRND 5 161.0	560001	NODAWAYCO 161.0	1	153	146.3	146.5	3.8%	Intact	XS542992>543035>\$1

635034	CLRND 5 161.0	560001	NODAWAYCO 161.0	1	153	146.3	146.5	3.8%	Intact	XS542972>542973>543645\$22
635034	CLRND 5 161.0	560001	NODAWAYCO 161.0	1	153	146.3	146.5	3.8%	Intact	XS533419>533513>533445\$1
635034	CLRND 5 161.0	560001	NODAWAYCO 161.0	1	153	146.3	146.5	3.8%	Intact	XS542969>542995>\$1
635034	CLRND 5 161.0	560001	NODAWAYCO 161.0	1	153	146.3	146.5	3.8%	Intact	XS631025>629089>\$2
635034	CLRND 5 161.0	560001	NODAWAYCO 161.0	1	153	146.3	146.5	3.8%	Intact	XS631025>629089>\$1
635034	CLRND 5 161.0	560001	NODAWAYCO 161.0	1	153	146.3	146.5	3.8%	Intact	XS631060>630282>\$1
635034	CLRND 5 161.0	560001	NODAWAYCO 161.0	1	153	146.3	146.5	3.8%	Intact	XS631009>629104>\$1
635034	CLRND 5 161.0	560001	NODAWAYCO 161.0	1	153	146.3	146.5	3.8%	Intact	XS631044>630129>\$1
635034	CLRND 5 161.0	560001	NODAWAYCO 161.0	1	153	146.3	146.5	3.8%	Intact	XS631056>630280>\$1
635034	CLRND 5 161.0	560001	NODAWAYCO 161.0	1	153	146.3	146.5	3.8%	Intact	XS631044>631127>\$1
635034	CLRND 5 161.0	560001	NODAWAYCO 161.0	1	153	146.3	146.5	3.8%	Intact	XS631064>636667>\$1
635034	CLRND 5 161.0	560001	NODAWAYCO 161.0	1	153	146.3	146.5	3.8%	Intact	XS631004>629105>\$2
635034	CLRND 5 161.0	560001	NODAWAYCO 161.0	1	153	146.3	146.5	3.8%	Intact	XS543063>543094>\$1
635034	CLRND 5 161.0	560001	NODAWAYCO 161.0	1	153	146.3	146.5	3.8%	Intact	XS613420>681530>\$1
635034	CLRND 5 161.0	560001	NODAWAYCO 161.0	1	153	146.3	146.5	3.8%	Intact	XS631004>629105>\$1
635034	CLRND 5 161.0	560001	NODAWAYCO 161.0	1	153	146.3	146.5	3.8%	Intact	XS631046>631122>\$1
635034	CLRND 5 161.0	560001	NODAWAYCO 161.0	1	153	146.3	146.5	3.8%	Intact	XS631090>631091>\$1
635034	CLRND 5 161.0	560001	NODAWAYCO 161.0	1	153	146.3	146.5	3.8%	Intact	XS631064>630005>\$1
635034	CLRND 5 161.0	560001	NODAWAYCO 161.0	1	153	146.3	146.5	3.8%	Intact	XS613370>613350>\$2
635034	CLRND 5 161.0	560001	NODAWAYCO 161.0	1	153	146.3	146.5	3.8%	Intact	XS631018>631031>\$1
635034	CLRND 5 161.0	560001	NODAWAYCO 161.0	1	153	146.3	146.5	3.8%	Intact	XS631014>629100>\$1
635034	CLRND 5 161.0	560001	NODAWAYCO 161.0	1	153	146.3	146.5	3.8%	Intact	XS631050>630257>\$1
635034	CLRND 5 161.0	560001	NODAWAYCO 161.0	1	153	146.3	146.5	3.8%	Intact	XS631089>631147>\$1
635034	CLRND 5 161.0	560001	NODAWAYCO 161.0	1	153	146.3	146.5	3.8%	Intact	XS631014>629100>\$2
635034	CLRND 5 161.0	560001	NODAWAYCO 161.0	1	153	146.3	146.5	3.8%	Intact	XS543105>543106>\$1

635034	CLRND 5 161.0	560001	NODAWAYCO 161.0	1	153	146.3	146.5	3.8%	Intact	XS631056>630281>\$1
635034	CLRND 5 161.0	560001	NODAWAYCO 161.0	1	153	146.3	146.5	3.8%	Intact	XS543069>543112>\$1
635034	CLRND 5 161.0	560001	NODAWAYCO 161.0	1	153	146.3	146.5	3.8%	Intact	XS631090>630026>\$1
635034	CLRND 5 161.0	560001	NODAWAYCO 161.0	1	153	146.3	146.5	3.8%	Intact	XS631009>631028>\$1
635034	CLRND 5 161.0	560001	NODAWAYCO 161.0	1	153	146.3	146.5	3.8%	Intact	XS631062>630176>\$1
635034	CLRND 5 161.0	560001	NODAWAYCO 161.0	1	153	146.3	146.5	3.8%	Intact	XS631041>631138>\$1
635034	CLRND 5 161.0	560001	NODAWAYCO 161.0	1	153	146.3	146.5	3.8%	Intact	XS631041>631138>\$2
635034	CLRND 5 161.0	560001	NODAWAYCO 161.0	1	153	146.3	146.5	3.8%	Intact	XS631008>631009>\$1
635034	CLRND 5 161.0	560001	NODAWAYCO 161.0	1	153	146.3	146.5	3.8%	Intact	XS631054>629064>\$1
635034	CLRND 5 161.0	560001	NODAWAYCO 161.0	1	153	146.3	146.5	3.8%	Intact	XS631039>630064>\$2
635034	CLRND 5 161.0	560001	NODAWAYCO 161.0	1	153	146.3	146.5	3.8%	Intact	XS631011>629114>\$1
635034	CLRND 5 161.0	560001	NODAWAYCO 161.0	1	153	146.3	146.5	3.8%	Intact	XS631019>631167>\$1
635034	CLRND 5 161.0	560001	NODAWAYCO 161.0	1	153	146.3	146.5	3.8%	Intact	XS631085>636401>\$1
635034	CLRND 5 161.0	560001	NODAWAYCO 161.0	1	153	146.3	146.5	3.8%	Intact	XS631054>629065>\$1
635034	CLRND 5 161.0	560001	NODAWAYCO 161.0	1	153	146.3	146.5	3.8%	Intact	XS631039>630064>\$1
635034	CLRND 5 161.0	560001	NODAWAYCO 161.0	1	153	146.3	146.5	3.8%	Intact	XS631043>630096>\$1
635034	CLRND 5 161.0	560001	NODAWAYCO 161.0	1	153	146.3	146.5	3.8%	Intact	XS631019>631027>\$1
635034	CLRND 5 161.0	560001	NODAWAYCO 161.0	1	153	146.3	146.5	3.8%	Intact	XS631051>630256>\$1
635034	CLRND 5 161.0	560001	NODAWAYCO 161.0	1	153	146.3	146.5	3.8%	Intact	XS543636>543637>\$1
635034	CLRND 5 161.0	560001	NODAWAYCO 161.0	1	153	146.3	146.5	3.8%	Intact	XS631043>602003>\$1
635034	CLRND 5 161.0	560001	NODAWAYCO 161.0	1	153	146.3	146.5	3.8%	Intact	XS543112>543078>\$1
635034	CLRND 5 161.0	560001	NODAWAYCO 161.0	1	153	146.3	146.5	3.8%	Intact	XS580070>580071>\$1
635034	CLRND 5 161.0	560001	NODAWAYCO 161.0	1	153	146.3	146.5	3.8%	Intact	XS631019>629087>\$2
635034	CLRND 5 161.0	560001	NODAWAYCO 161.0	1	153	146.3	146.5	3.8%	Intact	XS613370>613350>\$1
635034	CLRND 5 161.0	560001	NODAWAYCO 161.0	1	153	146.3	146.5	3.8%	Intact	XS543105>543109>\$1

635034	CLRND 5 161.0	560001	NODAWAYCO 161.0	1	153	146.3	146.5	3.8%	Intact	XS618900>631039>\$1
635034	CLRND 5 161.0	560001	NODAWAYCO 161.0	1	153	146.3	146.5	3.8%	Intact	XS580070>648500>\$1
635034	CLRND 5 161.0	560001	NODAWAYCO 161.0	1	153	146.3	146.5	3.8%	Intact	XS543105>543108>\$1
635034	CLRND 5 161.0	560001	NODAWAYCO 161.0	1	153	146.3	146.5	3.8%	Intact	XS543105>543107>\$1
635034	CLRND 5 161.0	560001	NODAWAYCO 161.0	1	153	146.3	146.5	3.8%	Intact	XS631019>629087>\$1
635034	CLRND 5 161.0	560001	NODAWAYCO 161.0	1	153	146.3	146.5	3.8%	Intact	XS631011>629114>\$2
635034	CLRND 5 161.0	560001	NODAWAYCO 161.0	1	153	146.3	146.5	3.8%	Intact	XS631017>629085>\$1
635034	CLRND 5 161.0	560001	NODAWAYCO 161.0	1	153	146.3	146.5	3.8%	Intact	XS631047>631155>\$1
635034	CLRND 5 161.0	560001	NODAWAYCO 161.0	1	153	146.3	146.5	3.8%	Intact	XS618900>631040>\$1
635034	CLRND 5 161.0	560001	NODAWAYCO 161.0	1	153	146.3	146.5	3.8%	Intact	XS631016>629086>\$2
635034	CLRND 5 161.0	560001	NODAWAYCO 161.0	1	153	146.3	146.5	3.8%	Intact	XS631091>629097>\$1
635034	CLRND 5 161.0	560001	NODAWAYCO 161.0	1	153	146.3	146.5	3.8%	Intact	XS631047>630198>\$1
635034	CLRND 5 161.0	560001	NODAWAYCO 161.0	1	153	146.3	146.5	3.8%	Intact	XS631017>629085>\$2
635034	CLRND 5 161.0	560001	NODAWAYCO 161.0	1	153	146.3	146.5	3.8%	Intact	XS631027>631146>\$1
635034	CLRND 5 161.0	560001	NODAWAYCO 161.0	1	153	146.3	146.5	3.8%	Intact	XS631047>630197>\$1
635034	CLRND 5 161.0	560001	NODAWAYCO 161.0	1	153	146.3	146.5	3.8%	Intact	XS631066>629116>\$1
635034	CLRND 5 161.0	560001	NODAWAYCO 161.0	1	153	146.3	146.5	3.8%	Intact	XS631016>631168>\$1
635034	CLRND 5 161.0	560001	NODAWAYCO 161.0	1	153	146.3	146.5	3.8%	Intact	XS631017>631019>\$1
635034	CLRND 5 161.0	560001	NODAWAYCO 161.0	1	153	146.3	146.5	3.8%	Intact	XS631065>630004>\$1
635034	CLRND 5 161.0	560001	NODAWAYCO 161.0	1	153	146.3	146.5	3.8%	Intact	XS631018>631168>\$1
635034	CLRND 5 161.0	560001	NODAWAYCO 161.0	1	153	146.3	146.5	3.8%	Intact	XS631064>630005>\$2
635034	CLRND 5 161.0	560001	NODAWAYCO 161.0	1	153	146.3	146.5	3.8%	Intact	XS631001>629101>\$2
635034	CLRND 5 161.0	560001	NODAWAYCO 161.0	1	153	146.3	146.5	3.8%	Intact	XS631031>631167>\$1
635034	CLRND 5 161.0	560001	NODAWAYCO 161.0	1	153	146.3	146.5	3.8%	Intact	XS631066>629117>\$1
635034	CLRND 5 161.0	560001	NODAWAYCO 161.0	1	153	146.3	146.5	3.8%	Intact	XS631001>629101>\$1

635034	CLRND 5 161.0	560001	NODAWAYCO 161.0	1	153	146.3	146.5	3.8%	Intact	XS631090>631181>\$1
635034	CLRND 5 161.0	560001	NODAWAYCO 161.0	1	153	146.3	146.5	3.8%	Intact	XS631016>629086>\$1
635034	CLRND 5 161.0	560001	NODAWAYCO 161.0	1	153	146.3	146.5	3.8%	Intact	XS631077>629112>\$1
635034	CLRND 5 161.0	560001	NODAWAYCO 161.0	1	153	146.3	146.5	3.8%	Intact	XS631046>631123>\$1
635034	CLRND 5 161.0	560001	NODAWAYCO 161.0	1	153	146.2	146.4	3.8%	Intact	XS631097>629094>\$1
635034	CLRND 5 161.0	560001	NODAWAYCO 161.0	1	153	146.2	146.4	3.8%	Intact	XS640196>640198>\$1
635034	CLRND 5 161.0	560001	NODAWAYCO 161.0	1	153	146.2	146.4	3.8%	Intact	XS640375>640376>\$1
635034	CLRND 5 161.0	560001	NODAWAYCO 161.0	1	153	146.2	146.4	3.8%	Intact	XS640397>640398>\$1
635034	CLRND 5 161.0	560001	NODAWAYCO 161.0	1	153	146.2	146.4	3.8%	Intact	XS640256>640257>\$1
635034	CLRND 5 161.0	560001	NODAWAYCO 161.0	1	153	146.2	146.4	3.8%	Intact	XS645023>645123>\$1
635034	CLRND 5 161.0	560001	NODAWAYCO 161.0	1	153	146.2	146.4	3.8%	Intact	XS640392>640393>\$1
635034	CLRND 5 161.0	560001	NODAWAYCO 161.0	1	153	146.2	146.4	3.8%	Intact	XS650283>650383>650583\$1
635034	CLRND 5 161.0	560001	NODAWAYCO 161.0	1	153	146.2	146.4	3.8%	Intact	XS650283>650483>650683\$1
635034	CLRND 5 161.0	560001	NODAWAYCO 161.0	1	153	146.2	146.4	3.8%	Intact	XS650284>650384>650584\$1
635034	CLRND 5 161.0	560001	NODAWAYCO 161.0	1	153	146.2	146.4	3.8%	Intact	XS646222>646229>\$1
635034	CLRND 5 161.0	560001	NODAWAYCO 161.0	1	153	146.2	146.4	3.8%	Intact	XS646206>647006>648306\$1
635034	CLRND 5 161.0	560001	NODAWAYCO 161.0	1	153	146.2	146.4	3.8%	Intact	XS646216>646217>\$1
635034	CLRND 5 161.0	560001	NODAWAYCO 161.0	1	153	146.2	146.4	3.8%	Intact	XS647904>647985>\$1
635034	CLRND 5 161.0	560001	NODAWAYCO 161.0	1	153	146.2	146.4	3.8%	Intact	XS300042>300045>\$1
635034	CLRND 5 161.0	560001	NODAWAYCO 161.0	1	153	146.2	146.4	3.8%	Intact	MC1216-917
635034	CLRND 5 161.0	560001	NODAWAYCO 161.0	1	153	146.2	146.4	3.8%	Intact	XS300617>344815>\$1
635034	CLRND 5 161.0	560001	NODAWAYCO 161.0	1	153	146.2	146.4	3.8%	Intact	XS533338>560141>\$1
635034	CLRND 5 161.0	560001	NODAWAYCO 161.0	1	153	146.2	146.4	3.8%	Intact	XS652517>652230>\$1
635034	CLRND 5 161.0	560001	NODAWAYCO 161.0	1	153	146.2	146.4	3.8%	Intact	1297TARP
635034	CLRND 5 161.0	560001	NODAWAYCO 161.0	1	153	146.2	146.4	3.8%	Intact	XS631001>631004>\$1

635034	CLRND 5 161.0	560001	NODAWAYCO 161.0	1	153	146	146.3	3.8%	Intact	XS635601>635608>\$1
635034	CLRND 5 161.0	560001	NODAWAYCO 161.0	1	153	146.1	146.3	3.8%	Intact	XS631138>601034>\$1
635034	CLRND 5 161.0	560001	NODAWAYCO 161.0	1	153	146.1	146.3	3.8%	Intact	XS640070>640071>\$1
635034	CLRND 5 161.0	560001	NODAWAYCO 161.0	1	153	146.1	146.3	3.8%	Intact	XS640176>640177>\$1
635034	CLRND 5 161.0	560001	NODAWAYCO 161.0	1	153	146.1	146.3	3.8%	Intact	XS640054>640176>\$1
635034	CLRND 5 161.0	560001	NODAWAYCO 161.0	1	153	146.1	146.3	3.8%	Intact	XS640169>640170>\$1
635034	CLRND 5 161.0	560001	NODAWAYCO 161.0	1	153	146.1	146.3	3.8%	Intact	XS640259>640260>643095\$1
635034	CLRND 5 161.0	560001	NODAWAYCO 161.0	1	153	146.1	146.3	3.8%	Intact	XS640256>640258>\$1
635034	CLRND 5 161.0	560001	NODAWAYCO 161.0	1	153	146.1	146.3	3.8%	Intact	XS640383>640384>\$1
635034	CLRND 5 161.0	560001	NODAWAYCO 161.0	1	153	146.1	146.3	3.8%	Intact	XS647108>647110>\$1
635034	CLRND 5 161.0	560001	NODAWAYCO 161.0	1	153	146	146.3	3.8%	Intact	XS650238>650438>650638\$1
635034	CLRND 5 161.0	560001	NODAWAYCO 161.0	1	153	146.1	146.3	3.8%	Intact	XS650256>650456>650656\$1
635034	CLRND 5 161.0	560001	NODAWAYCO 161.0	1	153	146	146.3	3.8%	Intact	XS650260>650460>650660\$1
635034	CLRND 5 161.0	560001	NODAWAYCO 161.0	1	153	146	146.3	3.8%	Intact	XS650260>650360>650560\$1
635034	CLRND 5 161.0	560001	NODAWAYCO 161.0	1	153	146	146.3	3.8%	Intact	XS650238>650338>650538\$1
635034	CLRND 5 161.0	560001	NODAWAYCO 161.0	1	153	146.1	146.3	3.8%	Intact	XS650273>650373>650573\$1
635034	CLRND 5 161.0	560001	NODAWAYCO 161.0	1	153	146.1	146.3	3.8%	Intact	XS650256>650356>650556\$1
635034	CLRND 5 161.0	560001	NODAWAYCO 161.0	1	153	146.1	146.3	3.8%	Intact	XS650255>650355>650555\$1
635034	CLRND 5 161.0	560001	NODAWAYCO 161.0	1	153	146.1	146.3	3.8%	Intact	CB906S-BT63
635034	CLRND 5 161.0	560001	NODAWAYCO 161.0	1	153	146.1	146.3	3.8%	Intact	906N15-25-94
635034	CLRND 5 161.0	560001	NODAWAYCO 161.0	1	153	146.1	146.3	3.8%	Intact	CB994-BUS06N
635034	CLRND 5 161.0	560001	NODAWAYCO 161.0	1	153	146.1	146.3	3.8%	Intact	CB1250-11&97
635034	CLRND 5 161.0	560001	NODAWAYCO 161.0	1	153	146.1	146.3	3.8%	Intact	LES7006
635034	CLRND 5 161.0	560001	NODAWAYCO 161.0	1	153	146.1	146.3	3.8%	Intact	LES0013
635034	CLRND 5 161.0	560001	NODAWAYCO 161.0	1	153	146.1	146.3	3.8%	Intact	XS541250>548808>\$1

635034	CLRND 5 161.0	560001	NODAWAYCO 161.0	1	153	146.1	146.3	3.8%	Intact	XS631091>629106>\$1
635034	CLRND 5 161.0	560001	NODAWAYCO 161.0	1	153	146.1	146.3	3.8%	Intact	XS631012>629102>\$1
635034	CLRND 5 161.0	560001	NODAWAYCO 161.0	1	153	145.9	146.2	3.8%	Intact	XS542965>542977>\$1
635034	CLRND 5 161.0	560001	NODAWAYCO 161.0	1	153	146	146.2	3.8%	Intact	XS636635>636640>\$1
635034	CLRND 5 161.0	560001	NODAWAYCO 161.0	1	153	146	146.2	3.8%	Intact	XS650259>650359>650559\$1
635034	CLRND 5 161.0	560001	NODAWAYCO 161.0	1	153	146	146.2	3.8%	Intact	XS650252>650352>650552\$1
635034	CLRND 5 161.0	560001	NODAWAYCO 161.0	1	153	146	146.2	3.8%	Intact	LES3002
635034	CLRND 5 161.0	560001	NODAWAYCO 161.0	1	153	146	146.2	3.8%	Intact	LES0014
635034	CLRND 5 161.0	560001	NODAWAYCO 161.0	1	153	146	146.2	3.8%	Intact	XS631007>631030>\$1
635034	CLRND 5 161.0	560001	NODAWAYCO 161.0	1	153	145.9	146.1	3.8%	Intact	XS640372>640373>\$1
635034	CLRND 5 161.0	560001	NODAWAYCO 161.0	1	153	145.9	146.1	3.8%	Intact	XS650229>650329>650529\$1
635034	CLRND 5 161.0	560001	NODAWAYCO 161.0	1	153	145.9	146.1	3.8%	Intact	XS300040>300054>\$1
635034	CLRND 5 161.0	560001	NODAWAYCO 161.0	1	153	145.9	146.1	3.8%	Intact	CB924-BUS
635034	CLRND 5 161.0	560001	NODAWAYCO 161.0	1	153	145.9	146.1	3.8%	Intact	CB1281-BUS
635034	CLRND 5 161.0	560001	NODAWAYCO 161.0	1	153	145.9	146.1	3.8%	Intact	1281LINBUS
635034	CLRND 5 161.0	560001	NODAWAYCO 161.0	1	153	145.8	146	3.8%	Intact	CB3451-RN&T4
635034	CLRND 5 161.0	560001	NODAWAYCO 161.0	1	153	145.7	145.9	3.8%	Intact	XS300046>300007>\$1
635034	CLRND 5 161.0	560001	NODAWAYCO 161.0	1	153	145.7	145.9	3.8%	Intact	XS541221>541350>\$1
635034	CLRND 5 161.0	560001	NODAWAYCO 161.0	1	153	145.6	145.9	3.8%	Intact	XS300069>300031>\$10
635034	CLRND 5 161.0	560001	NODAWAYCO 161.0	1	153	145.6	145.9	3.8%	Intact	XS300069>300021>\$22
635034	CLRND 5 161.0	560001	NODAWAYCO 161.0	1	153	145.6	145.9	3.8%	Intact	XS300069>300020>\$21
635034	CLRND 5 161.0	560001	NODAWAYCO 161.0	1	153	145.6	145.9	3.8%	Intact	XS300069>300032>\$11
635034	CLRND 5 161.0	560001	NODAWAYCO 161.0	1	153	145.6	145.8	3.8%	Intact	CB900BUS&979
635034	CLRND 5 161.0	560001	NODAWAYCO 161.0	1	153	145.5	145.7	3.8%	Intact	XS645454>645455>\$1
635034	CLRND 5 161.0	560001	NODAWAYCO 161.0	1	153	145.5	145.7	3.8%	Intact	CBWAG-T2-54

635034	CLRND 5 161.0	560001	NODAWAYCO 161.0	1	153	145.4	145.6	3.8%	Intact	XS640424>640425>643170\$1
635034	CLRND 5 161.0	560001	NODAWAYCO 161.0	1	153	145.3	145.6	3.8%	Intact	CB3454-55&WG
635034	CLRND 5 161.0	560001	NODAWAYCO 161.0	1	153	145.3	145.5	3.8%	Intact	CB3454-51&WG
635034	CLRND 5 161.0	560001	NODAWAYCO 161.0	1	153	145.2	145.4	3.8%	Intact	CB1286-BUS
635034	CLRND 5 161.0	560001	NODAWAYCO 161.0	1	153	145.1	145.3	3.8%	Intact	XS645455>645456>\$1
635034	CLRND 5 161.0	560001	NODAWAYCO 161.0	1	153	145.1	145.3	3.8%	Intact	CB1236-BUS
635034	CLRND 5 161.0	560001	NODAWAYCO 161.0	1	153	144.6	144.9	3.8%	Intact	XS542968>542981>\$1
635034	CLRND 5 161.0	560001	NODAWAYCO 161.0	1	153	144.3	144.6	3.8%	Intact	XS635680>635730>\$1
635034	CLRND 5 161.0	560001	NODAWAYCO 161.0	1	153	144.3	144.5	3.8%	Intact	XS531451>531465>\$1
635034	CLRND 5 161.0	560001	NODAWAYCO 161.0	1	153	143	143.2	3.8%	Intact	XS300049>300003>\$1
635034	CLRND 5 161.0	560001	NODAWAYCO 161.0	1	153	140.1	140.3	3.8%	Intact	XS532852>532651>\$1
635034	CLRND 5 161.0	560001	NODAWAYCO 161.0	1	153	137.1	137.3	3.8%	Intact	XS542982>542957>\$1
635034	CLRND 5 161.0	560001	NODAWAYCO 161.0	1	153	137	137.2	3.8%	Intact	XS541199>640139>\$1
635034	CLRND 5 161.0	560001	NODAWAYCO 161.0	1	153	136	136.2	3.8%	Intact	XS300039>560620>\$1
635034	CLRND 5 161.0	560001	NODAWAYCO 161.0	1	153	130	130.2	3.8%	Intact	XS560617>560618>\$1
635034	CLRND 5 161.0	560001	NODAWAYCO 161.0	1	153	130	130.2	3.8%	Intact	XS560001>560617>\$1
635034	CLRND 5 161.0	560001	NODAWAYCO 161.0	1	153	115.9	116.1	3.8%	Intact	XS635038>652560>\$1
560332	G10-47T 115.0	640208	HARBINE7 115.0	1	99	102.7	103.2	4.8%	Intact	XS532913>560610>\$1
640234	HUMBOLT5 161.0	3WNDTR	S975 T4 WND	1	67.2	101.8	102.5	4.8%	Intact	XS646263>646280>\$1

**Table C-3: 2012 Winter Contingency Analysis Thermal Violations
NERC Category B and C Single-Event Contingencies
Loading Limit 100%, DF > 3%, Screened
GEN-2010-041 10.5 MW Wind Project**

FromBusNum	FromBusName	ToBusNum	ToBusName	Circuit	Rating	Benchmark (%)	Change (%)	DF	Prior	Contingency
640088	BPS SUB7 115.0	640111	CLATONA7 115.0	1	137	102.3	102.9	8.6%	Intact	XS640088>640278>\$1
635034	CLRNDA 5 161.0	560001	NODAWAYCO 161.0	1	167	185.4	185.7	3.8%	Intact	XS300097>652560>\$1
635034	CLRNDA 5 161.0	560001	NODAWAYCO 161.0	1	167	158.2	158.4	3.8%	Intact	XS635017>635630>\$1
635034	CLRNDA 5 161.0	560001	NODAWAYCO 161.0	1	167	156.6	156.8	3.8%	Intact	FCS_GEN
635034	CLRNDA 5 161.0	560001	NODAWAYCO 161.0	1	167	156.6	156.8	3.8%	Intact	FCS_POSTTRIP
635034	CLRNDA 5 161.0	560001	NODAWAYCO 161.0	1	167	156.5	156.7	3.8%	Intact	CB3451-54&FC
635034	CLRNDA 5 161.0	560001	NODAWAYCO 161.0	1	167	154.6	154.8	3.8%	Intact	NC1_GEN
635034	CLRNDA 5 161.0	560001	NODAWAYCO 161.0	1	167	153.6	153.9	3.8%	Intact	XS640139>560620>\$1
635034	CLRNDA 5 161.0	560001	NODAWAYCO 161.0	1	167	153.5	153.7	4.8%	Intact	CB3458-40&CO
635034	CLRNDA 5 161.0	560001	NODAWAYCO 161.0	1	167	151.9	152.2	4.8%	Intact	XS640139>645458>\$1
635034	CLRNDA 5 161.0	560001	NODAWAYCO 161.0	1	167	151.5	151.7	3.8%	Intact	CB3455-40&T3
635034	CLRNDA 5 161.0	560001	NODAWAYCO 161.0	1	167	151.4	151.6	3.8%	Intact	XS645458>645740>\$1
635034	CLRNDA 5 161.0	560001	NODAWAYCO 161.0	1	167	150	150.2	3.8%	Intact	XS640139>640009>\$1
635034	CLRNDA 5 161.0	560001	NODAWAYCO 161.0	1	167	149.9	150.1	3.8%	Intact	XS640184>640010>\$1
635034	CLRNDA 5 161.0	560001	NODAWAYCO 161.0	1	167	149.2	149.4	3.8%	Intact	XS635000>635001>635026\$2
635034	CLRNDA 5 161.0	560001	NODAWAYCO 161.0	1	167	149	149.2	3.8%	Intact	XS641087>641089>\$1
635034	CLRNDA 5 161.0	560001	NODAWAYCO 161.0	1	167	149	149.2	3.8%	Intact	XS652507>652541>\$1
635034	CLRNDA 5 161.0	560001	NODAWAYCO 161.0	1	167	149	149.2	3.8%	Intact	XS300036>301310>\$1
635034	CLRNDA 5 161.0	560001	NODAWAYCO 161.0	1	167	148.8	149.1	3.8%	Intact	CB1280-BUS
635034	CLRNDA 5 161.0	560001	NODAWAYCO 161.0	1	167	148.8	149	3.8%	Intact	XS928113>640139>\$1

635034	CLRND 5 161.0	560001	NODAWAYCO 161.0	1	167	148.7	149	3.8%	Intact	CB1263-BUS
635034	CLRND 5 161.0	560001	NODAWAYCO 161.0	1	167	148.6	148.9	4.8%	Intact	BKR-HMB-1604
635034	CLRND 5 161.0	560001	NODAWAYCO 161.0	1	167	148.7	148.9	3.8%	Intact	MCWAG-103-OC
635034	CLRND 5 161.0	560001	NODAWAYCO 161.0	1	167	148.7	148.9	3.8%	Intact	CBWAG-T1-103
635034	CLRND 5 161.0	560001	NODAWAYCO 161.0	1	167	148.5	148.8	4.8%	Intact	XS640234>646399>\$1
635034	CLRND 5 161.0	560001	NODAWAYCO 161.0	1	167	148.4	148.6	3.8%	Intact	XS652603>658002>\$1
635034	CLRND 5 161.0	560001	NODAWAYCO 161.0	1	167	148.3	148.5	3.8%	Intact	FRE8_GEN
635034	CLRND 5 161.0	560001	NODAWAYCO 161.0	1	167	148.1	148.4	3.8%	Intact	CB1399-BUS
635034	CLRND 5 161.0	560001	NODAWAYCO 161.0	1	167	148.2	148.4	3.8%	Intact	XS631017>629066>\$1
635034	CLRND 5 161.0	560001	NODAWAYCO 161.0	1	167	148.1	148.3	3.8%	Intact	XS646258>646263>\$1
635034	CLRND 5 161.0	560001	NODAWAYCO 161.0	1	167	148.1	148.3	3.8%	Intact	XS646244>646258>\$1
635034	CLRND 5 161.0	560001	NODAWAYCO 161.0	1	167	148.1	148.3	3.8%	Intact	XS532775>542977>\$1
635034	CLRND 5 161.0	560001	NODAWAYCO 161.0	1	167	147.9	148.2	3.8%	Intact	BKR-MOR-3312
635034	CLRND 5 161.0	560001	NODAWAYCO 161.0	1	167	148	148.2	3.8%	Intact	CBHUM-80&T4
635034	CLRND 5 161.0	560001	NODAWAYCO 161.0	1	167	148	148.2	3.8%	Intact	TWR-ETR-RS
635034	CLRND 5 161.0	560001	NODAWAYCO 161.0	1	167	148	148.2	3.8%	Intact	XS532768>532796>\$1
635034	CLRND 5 161.0	560001	NODAWAYCO 161.0	1	167	147.9	148.1	3.8%	Intact	XS631166>631171>\$1
635034	CLRND 5 161.0	560001	NODAWAYCO 161.0	1	167	147.9	148.1	3.8%	Intact	XS642071>642067>\$1
635034	CLRND 5 161.0	560001	NODAWAYCO 161.0	1	167	147.9	148.1	3.8%	Intact	XS652510>652546>\$1
635034	CLRND 5 161.0	560001	NODAWAYCO 161.0	1	167	147.9	148.1	3.8%	Intact	XS645458>650189>\$1
635034	CLRND 5 161.0	560001	NODAWAYCO 161.0	1	167	147.9	148.1	3.8%	Intact	BKR-HLD-3003
635034	CLRND 5 161.0	560001	NODAWAYCO 161.0	1	167	147.9	148.1	3.8%	Intact	BKR-CE-3306
635034	CLRND 5 161.0	560001	NODAWAYCO 161.0	1	167	147.9	148.1	3.8%	Intact	BKR-HLD-3006
635034	CLRND 5 161.0	560001	NODAWAYCO 161.0	1	167	147.9	148.1	3.8%	Intact	XS541201>345408>\$1
635034	CLRND 5 161.0	560001	NODAWAYCO 161.0	1	167	147.9	148.1	3.8%	Intact	XS560550>560551>\$2

635034	CLRNDA 5 161.0	560001	NODAWAYCO 161.0	1	167	147.9	148.1	3.8%	Intact	XS560550>560551>\$1
635034	CLRNDA 5 161.0	560001	NODAWAYCO 161.0	1	167	146.9	148	18.1%	Intact	S1217 AUTOV2
635034	CLRNDA 5 161.0	560001	NODAWAYCO 161.0	1	167	147.8	148	3.8%	Intact	XS631141>270864>\$1
635034	CLRNDA 5 161.0	560001	NODAWAYCO 161.0	1	167	147.8	148	3.8%	Intact	XS645456>646206>648256\$1
635034	CLRNDA 5 161.0	560001	NODAWAYCO 161.0	1	167	147.8	148	3.8%	Intact	TWR-SCH-MN
635034	CLRNDA 5 161.0	560001	NODAWAYCO 161.0	1	167	147.7	147.9	3.8%	Intact	XS631140>631141>\$1
635034	CLRNDA 5 161.0	560001	NODAWAYCO 161.0	1	167	147.7	147.9	3.8%	Intact	XS646206>646244>\$1
635034	CLRNDA 5 161.0	560001	NODAWAYCO 161.0	1	167	147.7	147.9	3.8%	Intact	CB1206-44SC3
635034	CLRNDA 5 161.0	560001	NODAWAYCO 161.0	1	167	147.7	147.9	3.8%	Intact	XS631122>631176>\$1
635034	CLRNDA 5 161.0	560001	NODAWAYCO 161.0	1	167	147.7	147.9	3.8%	Intact	XS300039>541199>\$1
635034	CLRNDA 5 161.0	560001	NODAWAYCO 161.0	1	167	147.6	147.9	3.8%	Intact	CB1206-44&T1
635034	CLRNDA 5 161.0	560001	NODAWAYCO 161.0	1	167	147.6	147.8	3.8%	Intact	XS652607>659295>\$1
635034	CLRNDA 5 161.0	560001	NODAWAYCO 161.0	1	167	146.9	147.7	11.4%	Intact	S1210 AUTOV2
635034	CLRNDA 5 161.0	560001	NODAWAYCO 161.0	1	167	147.2	147.7	9.5%	Intact	S1221 AUTOV2
635034	CLRNDA 5 161.0	560001	NODAWAYCO 161.0	1	167	147.5	147.7	3.8%	Intact	XS635633>635636>\$1
635034	CLRNDA 5 161.0	560001	NODAWAYCO 161.0	1	167	147.5	147.7	3.8%	Intact	XS635041>635042>\$1
635034	CLRNDA 5 161.0	560001	NODAWAYCO 161.0	1	167	147.5	147.7	3.8%	Intact	XS635041>635043>\$2
635034	CLRNDA 5 161.0	560001	NODAWAYCO 161.0	1	167	147.5	147.7	3.8%	Intact	XS635633>635634>\$1
635034	CLRNDA 5 161.0	560001	NODAWAYCO 161.0	1	167	147.6	147.7	3.8%	Intact	XS635310>635311>\$1
635034	CLRNDA 5 161.0	560001	NODAWAYCO 161.0	1	167	147.5	147.7	3.8%	Intact	XS532793>300045>\$1
635034	CLRNDA 5 161.0	560001	NODAWAYCO 161.0	1	167	147.4	147.6	3.8%	Intact	XS635630>635631>635629\$1
635034	CLRNDA 5 161.0	560001	NODAWAYCO 161.0	1	167	147.4	147.6	3.8%	Intact	XS640404>652484>\$1
635034	CLRNDA 5 161.0	560001	NODAWAYCO 161.0	1	167	147.4	147.6	3.8%	Intact	XS636235>636237>\$1
635034	CLRNDA 5 161.0	560001	NODAWAYCO 161.0	1	167	147.4	147.6	3.8%	Intact	XS636029>636028>\$1
635034	CLRNDA 5 161.0	560001	NODAWAYCO 161.0	1	167	147.4	147.6	3.8%	Intact	XS647963>647977>\$1

635034	CLRND 5 161.0	560001	NODAWAYCO 161.0	1	167	147.4	147.6	3.8%	Intact	XS636235>636234>\$2
635034	CLRND 5 161.0	560001	NODAWAYCO 161.0	1	167	147.4	147.6	3.8%	Intact	XS640374>652571>\$1
635034	CLRND 5 161.0	560001	NODAWAYCO 161.0	1	167	147.4	147.6	3.8%	Intact	XS635600>635630>\$1
635034	CLRND 5 161.0	560001	NODAWAYCO 161.0	1	167	147.4	147.6	3.8%	Intact	XS542972>541201>\$1
635034	CLRND 5 161.0	560001	NODAWAYCO 161.0	1	167	147.3	147.5	3.8%	Intact	XS640125>640342>\$1
635034	CLRND 5 161.0	560001	NODAWAYCO 161.0	1	167	147.3	147.5	3.8%	Intact	XS631115>631143>\$1
635034	CLRND 5 161.0	560001	NODAWAYCO 161.0	1	167	147.3	147.5	3.8%	Intact	XS640444>640433>\$1
635034	CLRND 5 161.0	560001	NODAWAYCO 161.0	1	167	147.3	147.5	3.8%	Intact	XS541255>541355>\$1
635034	CLRND 5 161.0	560001	NODAWAYCO 161.0	1	167	147.3	147.5	3.8%	Intact	XS631148>636420>\$1
635034	CLRND 5 161.0	560001	NODAWAYCO 161.0	1	167	147.4	147.5	3.8%	Intact	XS532765>533163>532804\$1
635034	CLRND 5 161.0	560001	NODAWAYCO 161.0	1	167	147	147.4	6.7%	Intact	S1221 AUTOV3
635034	CLRND 5 161.0	560001	NODAWAYCO 161.0	1	167	147.2	147.4	3.8%	Intact	XS635640>635641>\$1
635034	CLRND 5 161.0	560001	NODAWAYCO 161.0	1	167	147.2	147.4	3.8%	Intact	XS636029>636036>\$1
635034	CLRND 5 161.0	560001	NODAWAYCO 161.0	1	167	147.2	147.4	3.8%	Intact	XS635003>635004>\$1
635034	CLRND 5 161.0	560001	NODAWAYCO 161.0	1	167	147.2	147.4	3.8%	Intact	XS652507>652606>\$1
635034	CLRND 5 161.0	560001	NODAWAYCO 161.0	1	167	147.2	147.4	3.8%	Intact	XS652607>659122>\$1
635034	CLRND 5 161.0	560001	NODAWAYCO 161.0	1	167	147.2	147.4	3.8%	Intact	XS646221>646255>\$1
635034	CLRND 5 161.0	560001	NODAWAYCO 161.0	1	167	147.2	147.4	3.8%	Intact	XS300071>300108>\$1
635034	CLRND 5 161.0	560001	NODAWAYCO 161.0	1	167	147.2	147.4	3.8%	Intact	MC1221-31-55
635034	CLRND 5 161.0	560001	NODAWAYCO 161.0	1	167	147.2	147.4	3.8%	Intact	CB1254-BUS
635034	CLRND 5 161.0	560001	NODAWAYCO 161.0	1	167	147.2	147.4	3.8%	Intact	CBWAG-T2-54
635034	CLRND 5 161.0	560001	NODAWAYCO 161.0	1	167	147.2	147.4	3.8%	Intact	CBWAG-T1-54
635034	CLRND 5 161.0	560001	NODAWAYCO 161.0	1	167	147.2	147.4	3.8%	Intact	XS532873>530592>\$1
635034	CLRND 5 161.0	560001	NODAWAYCO 161.0	1	167	147.2	147.4	3.8%	Intact	S1263T1 AUTO
635034	CLRND 5 161.0	560001	NODAWAYCO 161.0	1	167	147.2	147.4	3.8%	Intact	S3454T1 AUTO

635034	CLRND 5 161.0	560001	NODAWAYCO 161.0	1	167	147.2	147.4	3.8%	Intact	XS631053>629073>\$1
635034	CLRND 5 161.0	560001	NODAWAYCO 161.0	1	167	147.2	147.4	3.8%	Intact	XS541207>541240>\$1
635034	CLRND 5 161.0	560001	NODAWAYCO 161.0	1	167	147.1	147.3	3.8%	Intact	XS631139>631144>\$1
635034	CLRND 5 161.0	560001	NODAWAYCO 161.0	1	167	147.1	147.3	3.8%	Intact	XS640234>647975>648275\$1
635034	CLRND 5 161.0	560001	NODAWAYCO 161.0	1	167	147.1	147.3	3.8%	Intact	XS631144>601002>\$1
635034	CLRND 5 161.0	560001	NODAWAYCO 161.0	1	167	147.1	147.3	3.8%	Intact	XS640136>640336>\$1
635034	CLRND 5 161.0	560001	NODAWAYCO 161.0	1	167	147.1	147.3	3.8%	Intact	XS636630>636640>\$1
635034	CLRND 5 161.0	560001	NODAWAYCO 161.0	1	167	147.1	147.3	3.8%	Intact	XS640267>640381>\$1
635034	CLRND 5 161.0	560001	NODAWAYCO 161.0	1	167	147.1	147.3	3.8%	Intact	XS645455>646255>648355\$1
635034	CLRND 5 161.0	560001	NODAWAYCO 161.0	1	167	147.1	147.3	3.8%	Intact	XS645455>646255>648255\$1
635034	CLRND 5 161.0	560001	NODAWAYCO 161.0	1	167	147.1	147.3	3.8%	Intact	XS652503>620314>\$1
635034	CLRND 5 161.0	560001	NODAWAYCO 161.0	1	167	147.1	147.3	3.8%	Intact	XS652509>652526>\$1
635034	CLRND 5 161.0	560001	NODAWAYCO 161.0	1	167	147.1	147.3	3.8%	Intact	XS543065>543069>\$1
635034	CLRND 5 161.0	560001	NODAWAYCO 161.0	1	167	147.1	147.3	3.8%	Intact	XS613330>693755>\$1
635034	CLRND 5 161.0	560001	NODAWAYCO 161.0	1	167	147.1	147.3	3.8%	Intact	XS636610>636615>\$1
635034	CLRND 5 161.0	560001	NODAWAYCO 161.0	1	167	147.1	147.3	3.8%	Intact	XS635310>635320>\$1
635034	CLRND 5 161.0	560001	NODAWAYCO 161.0	1	167	147.1	147.3	3.8%	Intact	XS640050>640096>\$1
635034	CLRND 5 161.0	560001	NODAWAYCO 161.0	1	167	147.1	147.3	3.8%	Intact	XS640096>640381>\$1
635034	CLRND 5 161.0	560001	NODAWAYCO 161.0	1	167	147.1	147.3	3.8%	Intact	XS640109>640334>\$1
635034	CLRND 5 161.0	560001	NODAWAYCO 161.0	1	167	147.1	147.3	3.8%	Intact	XS652509>652565>\$1
635034	CLRND 5 161.0	560001	NODAWAYCO 161.0	1	167	147	147.3	3.8%	Intact	XS650185>645454>\$1
635034	CLRND 5 161.0	560001	NODAWAYCO 161.0	1	167	147.1	147.3	3.8%	Intact	XS532794>514803>\$1
635034	CLRND 5 161.0	560001	NODAWAYCO 161.0	1	167	147.1	147.3	3.8%	Intact	XS300110>300124>\$1
635034	CLRND 5 161.0	560001	NODAWAYCO 161.0	1	167	147.1	147.3	3.8%	Intact	XS300044>345088>\$1
635034	CLRND 5 161.0	560001	NODAWAYCO 161.0	1	167	147	147.3	3.8%	Intact	CB3454-51&WG

635034	CLRND 5 161.0	560001	NODAWAYCO 161.0	1	167	147.1	147.3	3.8%	Intact	BKR-WAG-3006
635034	CLRND 5 161.0	560001	NODAWAYCO 161.0	1	167	147.1	147.3	3.8%	Intact	XS541244>541250>\$1
635034	CLRND 5 161.0	560001	NODAWAYCO 161.0	1	167	147.1	147.3	3.8%	Intact	XS543028>541230>\$1
635034	CLRND 5 161.0	560001	NODAWAYCO 161.0	1	167	147.1	147.3	3.8%	Intact	XS631081>631082>\$1
635034	CLRND 5 161.0	560001	NODAWAYCO 161.0	1	167	147	147.2	3.8%	Intact	XS635202>635300>\$1
635034	CLRND 5 161.0	560001	NODAWAYCO 161.0	1	167	147	147.2	3.8%	Intact	XS636600>636605>\$1
635034	CLRND 5 161.0	560001	NODAWAYCO 161.0	1	167	147	147.2	3.8%	Intact	XS640226>640227>643082\$1
635034	CLRND 5 161.0	560001	NODAWAYCO 161.0	1	167	147	147.2	3.8%	Intact	XS635632>635833>\$1
635034	CLRND 5 161.0	560001	NODAWAYCO 161.0	1	167	147	147.2	3.8%	Intact	XS646217>646227>\$1
635034	CLRND 5 161.0	560001	NODAWAYCO 161.0	1	167	147	147.2	3.8%	Intact	XS646214>647014>648214\$1
635034	CLRND 5 161.0	560001	NODAWAYCO 161.0	1	167	147	147.2	3.8%	Intact	XS652507>652509>\$1
635034	CLRND 5 161.0	560001	NODAWAYCO 161.0	1	167	147	147.2	3.8%	Intact	XS652514>659205>\$1
635034	CLRND 5 161.0	560001	NODAWAYCO 161.0	1	167	147	147.2	3.8%	Intact	XS650238>650242>\$1
635034	CLRND 5 161.0	560001	NODAWAYCO 161.0	1	167	147	147.2	3.8%	Intact	XS652507>652516>\$1
635034	CLRND 5 161.0	560001	NODAWAYCO 161.0	1	167	147	147.2	3.8%	Intact	XS646233>646255>\$1
635034	CLRND 5 161.0	560001	NODAWAYCO 161.0	1	167	147	147.2	3.8%	Intact	XS646221>646231>\$1
635034	CLRND 5 161.0	560001	NODAWAYCO 161.0	1	167	147	147.2	3.8%	Intact	XS647101>647975>\$1
635034	CLRND 5 161.0	560001	NODAWAYCO 161.0	1	167	147	147.2	3.8%	Intact	XS652529>659160>\$1
635034	CLRND 5 161.0	560001	NODAWAYCO 161.0	1	167	147	147.2	3.8%	Intact	XS652523>652578>\$1
635034	CLRND 5 161.0	560001	NODAWAYCO 161.0	1	167	147	147.2	3.8%	Intact	XS647111>647967>\$1
635034	CLRND 5 161.0	560001	NODAWAYCO 161.0	1	167	147	147.2	3.8%	Intact	XS647402>647971>\$1
635034	CLRND 5 161.0	560001	NODAWAYCO 161.0	1	167	147	147.2	3.8%	Intact	XS532770>532863>532809\$1
635034	CLRND 5 161.0	560001	NODAWAYCO 161.0	1	167	147	147.2	3.8%	Intact	XS300071>300124>\$1
635034	CLRND 5 161.0	560001	NODAWAYCO 161.0	1	167	147	147.2	3.8%	Intact	MC1209-1250
635034	CLRND 5 161.0	560001	NODAWAYCO 161.0	1	167	147	147.2	3.8%	Intact	LES3804B

635034	CLRNDA 5 161.0	560001	NODAWAYCO 161.0	1	167	147	147.2	3.8%	Intact	XS300107>300290>\$1
635034	CLRNDA 5 161.0	560001	NODAWAYCO 161.0	1	167	147	147.2	3.8%	Intact	MC1214-14-46
635034	CLRNDA 5 161.0	560001	NODAWAYCO 161.0	1	167	147	147.2	3.8%	Intact	CB1259-BUS
635034	CLRNDA 5 161.0	560001	NODAWAYCO 161.0	1	167	147	147.2	3.8%	Intact	XS300499>300953>\$1
635034	CLRNDA 5 161.0	560001	NODAWAYCO 161.0	1	167	147	147.2	3.8%	Intact	XS532874>533359>532817\$1
635034	CLRNDA 5 161.0	560001	NODAWAYCO 161.0	1	167	147	147.2	3.8%	Intact	XS532871>532872>\$1
635034	CLRNDA 5 161.0	560001	NODAWAYCO 161.0	1	167	147	147.2	3.8%	Intact	CB971-BUS
635034	CLRNDA 5 161.0	560001	NODAWAYCO 161.0	1	167	147	147.2	3.8%	Intact	XS300066>300953>\$1
635034	CLRNDA 5 161.0	560001	NODAWAYCO 161.0	1	167	147	147.2	3.8%	Intact	XS533015>533016>\$1
635034	CLRNDA 5 161.0	560001	NODAWAYCO 161.0	1	167	147	147.2	3.8%	Intact	XS541255>541256>\$1
635034	CLRNDA 5 161.0	560001	NODAWAYCO 161.0	1	167	147	147.2	3.8%	Intact	XS631041>631124>\$1
635034	CLRNDA 5 161.0	560001	NODAWAYCO 161.0	1	167	147	147.2	3.8%	Intact	XS543067>543069>\$1
635034	CLRNDA 5 161.0	560001	NODAWAYCO 161.0	1	167	147	147.2	3.8%	Intact	XS533249>533250>\$1
635034	CLRNDA 5 161.0	560001	NODAWAYCO 161.0	1	167	147	147.2	3.8%	Intact	XS533419>530618>\$1
635034	CLRNDA 5 161.0	560001	NODAWAYCO 161.0	1	167	147	147.2	3.8%	Intact	XS543026>541230>\$1
635034	CLRNDA 5 161.0	560001	NODAWAYCO 161.0	1	167	147	147.2	3.8%	Intact	XS541228>541234>\$1
635034	CLRNDA 5 161.0	560001	NODAWAYCO 161.0	1	167	147	147.2	3.8%	Intact	XS533361>533887>\$1
635034	CLRNDA 5 161.0	560001	NODAWAYCO 161.0	1	167	147	147.2	3.8%	Intact	XS533220>533226>\$1
635034	CLRNDA 5 161.0	560001	NODAWAYCO 161.0	1	167	147	147.2	3.8%	Intact	XS631142>631148>\$1
635034	CLRNDA 5 161.0	560001	NODAWAYCO 161.0	1	167	147	147.2	3.8%	Intact	XS640107>640201>\$1
635034	CLRNDA 5 161.0	560001	NODAWAYCO 161.0	1	167	147	147.2	3.8%	Intact	XS646227>646231>\$1
635034	CLRNDA 5 161.0	560001	NODAWAYCO 161.0	1	167	147	147.2	3.8%	Intact	XS543057>543068>\$1
635034	CLRNDA 5 161.0	560001	NODAWAYCO 161.0	1	167	146.6	147.1	8.6%	Intact	S1217 AUTOV3
635034	CLRNDA 5 161.0	560001	NODAWAYCO 161.0	1	167	146.7	147.1	7.6%	Intact	S1210 AUTOV3
635034	CLRNDA 5 161.0	560001	NODAWAYCO 161.0	1	167	146.9	147.1	3.8%	Intact	XS631148>631149>\$1

635034	CLRND 5 161.0	560001	NODAWAYCO 161.0	1	167	146.9	147.1	3.8%	Intact	XS635660>635661>\$1
635034	CLRND 5 161.0	560001	NODAWAYCO 161.0	1	167	146.9	147.1	3.8%	Intact	XS640362>647974>\$1
635034	CLRND 5 161.0	560001	NODAWAYCO 161.0	1	167	146.9	147.1	3.8%	Intact	XS640228>640363>\$1
635034	CLRND 5 161.0	560001	NODAWAYCO 161.0	1	167	146.9	147.1	3.8%	Intact	XS635651>635670>\$1
635034	CLRND 5 161.0	560001	NODAWAYCO 161.0	1	167	146.9	147.1	3.8%	Intact	XS635651>635660>\$1
635034	CLRND 5 161.0	560001	NODAWAYCO 161.0	1	167	146.9	147.1	3.8%	Intact	XS640349>652510>\$1
635034	CLRND 5 161.0	560001	NODAWAYCO 161.0	1	167	146.9	147.1	3.8%	Intact	XS635201>635220>\$1
635034	CLRND 5 161.0	560001	NODAWAYCO 161.0	1	167	146.9	147.1	3.8%	Intact	XS636672>348915>\$2
635034	CLRND 5 161.0	560001	NODAWAYCO 161.0	1	167	146.9	147.1	3.8%	Intact	XS640115>640293>\$1
635034	CLRND 5 161.0	560001	NODAWAYCO 161.0	1	167	146.9	147.1	3.8%	Intact	XS631104>630030>\$1
635034	CLRND 5 161.0	560001	NODAWAYCO 161.0	1	167	146.9	147.1	3.8%	Intact	XS640238>640013>\$1
635034	CLRND 5 161.0	560001	NODAWAYCO 161.0	1	167	146.9	147.1	3.8%	Intact	XS640342>640343>643136\$1
635034	CLRND 5 161.0	560001	NODAWAYCO 161.0	1	167	146.9	147.1	3.8%	Intact	XS640117>640394>\$1
635034	CLRND 5 161.0	560001	NODAWAYCO 161.0	1	167	146.9	147.1	3.8%	Intact	XS640222>640224>\$1
635034	CLRND 5 161.0	560001	NODAWAYCO 161.0	1	167	146.9	147.1	3.8%	Intact	XS640404>640405>640406\$1
635034	CLRND 5 161.0	560001	NODAWAYCO 161.0	1	167	146.9	147.1	3.8%	Intact	XS640212>652511>\$1
635034	CLRND 5 161.0	560001	NODAWAYCO 161.0	1	167	146.9	147.1	3.8%	Intact	XS636421>630679>\$1
635034	CLRND 5 161.0	560001	NODAWAYCO 161.0	1	167	146.9	147.1	3.8%	Intact	XS636600>636601>\$1
635034	CLRND 5 161.0	560001	NODAWAYCO 161.0	1	167	146.9	147.1	3.8%	Intact	XS636600>636635>\$1
635034	CLRND 5 161.0	560001	NODAWAYCO 161.0	1	167	146.9	147.1	3.8%	Intact	XS635203>635235>\$1
635034	CLRND 5 161.0	560001	NODAWAYCO 161.0	1	167	146.9	147.1	3.8%	Intact	XS640226>640228>640231\$1
635034	CLRND 5 161.0	560001	NODAWAYCO 161.0	1	167	146.9	147.1	3.8%	Intact	XS640133>640343>\$1
635034	CLRND 5 161.0	560001	NODAWAYCO 161.0	1	167	146.9	147.1	3.8%	Intact	XS640375>640411>\$1
635034	CLRND 5 161.0	560001	NODAWAYCO 161.0	1	167	146.9	147.1	3.8%	Intact	XS631156>631175>\$1
635034	CLRND 5 161.0	560001	NODAWAYCO 161.0	1	167	146.9	147.1	3.8%	Intact	XS635665>635701>\$1

635034	CLRNDA 5 161.0	560001	NODAWAYCO 161.0	1	167	146.9	147.1	3.8%	Intact	XS636615>636616>636619\$1
635034	CLRNDA 5 161.0	560001	NODAWAYCO 161.0	1	167	146.9	147.1	3.8%	Intact	XS635670>635672>\$1
635034	CLRNDA 5 161.0	560001	NODAWAYCO 161.0	1	167	146.9	147.1	3.8%	Intact	XS635672>635673>\$1
635034	CLRNDA 5 161.0	560001	NODAWAYCO 161.0	1	167	146.9	147.1	3.8%	Intact	XS640222>640313>\$1
635034	CLRNDA 5 161.0	560001	NODAWAYCO 161.0	1	167	146.9	147.1	3.8%	Intact	XS640109>640147>\$1
635034	CLRNDA 5 161.0	560001	NODAWAYCO 161.0	1	167	146.9	147.1	3.8%	Intact	XS640284>640347>\$1
635034	CLRNDA 5 161.0	560001	NODAWAYCO 161.0	1	167	146.9	147.1	3.8%	Intact	XS635605>635614>\$1
635034	CLRNDA 5 161.0	560001	NODAWAYCO 161.0	1	167	146.9	147.1	3.8%	Intact	XS640089>640098>\$1
635034	CLRNDA 5 161.0	560001	NODAWAYCO 161.0	1	167	146.9	147.1	3.8%	Intact	XS640056>642068>\$1
635034	CLRNDA 5 161.0	560001	NODAWAYCO 161.0	1	167	146.9	147.1	3.8%	Intact	XS631122>681537>\$1
635034	CLRNDA 5 161.0	560001	NODAWAYCO 161.0	1	167	146.9	147.1	3.8%	Intact	XS640089>640094>\$1
635034	CLRNDA 5 161.0	560001	NODAWAYCO 161.0	1	167	146.9	147.1	3.8%	Intact	XS631113>630050>\$1
635034	CLRNDA 5 161.0	560001	NODAWAYCO 161.0	1	167	146.9	147.1	3.8%	Intact	XS631113>631117>\$1
635034	CLRNDA 5 161.0	560001	NODAWAYCO 161.0	1	167	146.9	147.1	3.8%	Intact	XS631121>631129>\$1
635034	CLRNDA 5 161.0	560001	NODAWAYCO 161.0	1	167	146.9	147.1	3.8%	Intact	XS635280>635281>\$1
635034	CLRNDA 5 161.0	560001	NODAWAYCO 161.0	1	167	146.9	147.1	3.8%	Intact	XS640078>640400>\$1
635034	CLRNDA 5 161.0	560001	NODAWAYCO 161.0	1	167	146.9	147.1	3.8%	Intact	XS640076>640088>\$2
635034	CLRNDA 5 161.0	560001	NODAWAYCO 161.0	1	167	146.9	147.1	3.8%	Intact	XS631116>630047>\$1
635034	CLRNDA 5 161.0	560001	NODAWAYCO 161.0	1	167	146.9	147.1	3.8%	Intact	XS640281>640336>\$1
635034	CLRNDA 5 161.0	560001	NODAWAYCO 161.0	1	167	146.9	147.1	3.8%	Intact	XS640271>652571>\$1
635034	CLRNDA 5 161.0	560001	NODAWAYCO 161.0	1	167	146.9	147.1	3.8%	Intact	XS640082>640326>\$1
635034	CLRNDA 5 161.0	560001	NODAWAYCO 161.0	1	167	146.9	147.1	3.8%	Intact	XS640080>640212>\$1
635034	CLRNDA 5 161.0	560001	NODAWAYCO 161.0	1	167	146.9	147.1	3.8%	Intact	XS640282>640321>\$1
635034	CLRNDA 5 161.0	560001	NODAWAYCO 161.0	1	167	146.9	147.1	3.8%	Intact	XS631115>631116>\$1
635034	CLRNDA 5 161.0	560001	NODAWAYCO 161.0	1	167	146.9	147.1	3.8%	Intact	XS640072>640296>\$1

635034	CLRNDA 5 161.0	560001	NODAWAYCO 161.0	1	167	146.9	147.1	3.8%	Intact	XS640072>640115>\$1
635034	CLRNDA 5 161.0	560001	NODAWAYCO 161.0	1	167	146.9	147.1	3.8%	Intact	XS640076>640088>\$1
635034	CLRNDA 5 161.0	560001	NODAWAYCO 161.0	1	167	146.9	147.1	3.8%	Intact	XS635223>652566>\$1
635034	CLRNDA 5 161.0	560001	NODAWAYCO 161.0	1	167	146.9	147.1	3.8%	Intact	XS640361>647966>\$1
635034	CLRNDA 5 161.0	560001	NODAWAYCO 161.0	1	167	146.9	147.1	3.8%	Intact	XS635220>635221>\$1
635034	CLRNDA 5 161.0	560001	NODAWAYCO 161.0	1	167	146.9	147.1	3.8%	Intact	XS636690>636691>\$1
635034	CLRNDA 5 161.0	560001	NODAWAYCO 161.0	1	167	146.9	147.1	3.8%	Intact	XS640105>640106>\$1
635034	CLRNDA 5 161.0	560001	NODAWAYCO 161.0	1	167	146.9	147.1	3.8%	Intact	XS640326>640365>\$1
635034	CLRNDA 5 161.0	560001	NODAWAYCO 161.0	1	167	146.9	147.1	3.8%	Intact	XS635223>635225>\$1
635034	CLRNDA 5 161.0	560001	NODAWAYCO 161.0	1	167	146.9	147.1	3.8%	Intact	XS640102>640103>643029\$1
635034	CLRNDA 5 161.0	560001	NODAWAYCO 161.0	1	167	146.9	147.1	3.8%	Intact	XS640100>640269>\$1
635034	CLRNDA 5 161.0	560001	NODAWAYCO 161.0	1	167	146.9	147.1	3.8%	Intact	XS640261>640321>\$1
635034	CLRNDA 5 161.0	560001	NODAWAYCO 161.0	1	167	146.9	147.1	3.8%	Intact	XS631128>631156>\$1
635034	CLRNDA 5 161.0	560001	NODAWAYCO 161.0	1	167	146.9	147.1	3.8%	Intact	XS640093>640094>643026\$1
635034	CLRNDA 5 161.0	560001	NODAWAYCO 161.0	1	167	146.9	147.1	3.8%	Intact	XS640093>640102>\$1
635034	CLRNDA 5 161.0	560001	NODAWAYCO 161.0	1	167	146.9	147.1	3.8%	Intact	XS635260>635360>\$1
635034	CLRNDA 5 161.0	560001	NODAWAYCO 161.0	1	167	146.9	147.1	3.8%	Intact	XS631110>630048>\$2
635034	CLRNDA 5 161.0	560001	NODAWAYCO 161.0	1	167	146.9	147.1	3.8%	Intact	XS640316>650214>\$1
635034	CLRNDA 5 161.0	560001	NODAWAYCO 161.0	1	167	146.9	147.1	3.8%	Intact	XS640312>640313>640315\$1
635034	CLRNDA 5 161.0	560001	NODAWAYCO 161.0	1	167	146.9	147.1	3.8%	Intact	XS631110>630048>\$1
635034	CLRNDA 5 161.0	560001	NODAWAYCO 161.0	1	167	146.9	147.1	3.8%	Intact	XS635235>635236>\$1
635034	CLRNDA 5 161.0	560001	NODAWAYCO 161.0	1	167	146.9	147.1	3.8%	Intact	XS631129>630718>\$1
635034	CLRNDA 5 161.0	560001	NODAWAYCO 161.0	1	167	146.9	147.1	3.8%	Intact	XS640316>640340>\$1
635034	CLRNDA 5 161.0	560001	NODAWAYCO 161.0	1	167	146.9	147.1	3.8%	Intact	XS635610>635616>\$1
635034	CLRNDA 5 161.0	560001	NODAWAYCO 161.0	1	167	146.9	147.1	3.8%	Intact	XS636001>656369>\$1

635034	CLRNDA 5 161.0	560001	NODAWAYCO 161.0	1	167	146.9	147.1	3.8%	Intact	XS631093>636400>\$1
635034	CLRNDA 5 161.0	560001	NODAWAYCO 161.0	1	167	146.9	147.1	3.8%	Intact	XS636225>638030>\$1
635034	CLRNDA 5 161.0	560001	NODAWAYCO 161.0	1	167	146.9	147.1	3.8%	Intact	XS636300>656087>\$1
635034	CLRNDA 5 161.0	560001	NODAWAYCO 161.0	1	167	146.9	147.1	3.8%	Intact	XS640200>640330>\$1
635034	CLRNDA 5 161.0	560001	NODAWAYCO 161.0	1	167	146.9	147.1	3.8%	Intact	XS640171>640362>\$1
635034	CLRNDA 5 161.0	560001	NODAWAYCO 161.0	1	167	146.9	147.1	3.8%	Intact	XS631088>631149>\$1
635034	CLRNDA 5 161.0	560001	NODAWAYCO 161.0	1	167	146.9	147.1	3.8%	Intact	XS640208>640426>\$1
635034	CLRNDA 5 161.0	560001	NODAWAYCO 161.0	1	167	146.9	147.1	3.8%	Intact	XS636210>636220>\$1
635034	CLRNDA 5 161.0	560001	NODAWAYCO 161.0	1	167	146.9	147.1	3.8%	Intact	XS635705>635710>\$1
635034	CLRNDA 5 161.0	560001	NODAWAYCO 161.0	1	167	146.9	147.1	3.8%	Intact	XS647919>647950>\$1
635034	CLRNDA 5 161.0	560001	NODAWAYCO 161.0	1	167	146.9	147.1	3.8%	Intact	XS659130>659132>\$1
635034	CLRNDA 5 161.0	560001	NODAWAYCO 161.0	1	167	146.9	147.1	3.8%	Intact	XS659130>659188>\$1
635034	CLRNDA 5 161.0	560001	NODAWAYCO 161.0	1	167	146.9	147.1	3.8%	Intact	XS652626>660007>\$1
635034	CLRNDA 5 161.0	560001	NODAWAYCO 161.0	1	167	146.9	147.1	3.8%	Intact	XS646231>646235>\$1
635034	CLRNDA 5 161.0	560001	NODAWAYCO 161.0	1	167	146.9	147.1	3.8%	Intact	XS645128>646211>\$1
635034	CLRNDA 5 161.0	560001	NODAWAYCO 161.0	1	167	146.9	147.1	3.8%	Intact	XS659134>659210>\$1
635034	CLRNDA 5 161.0	560001	NODAWAYCO 161.0	1	167	146.9	147.1	3.8%	Intact	XS646250>647950>648250\$1
635034	CLRNDA 5 161.0	560001	NODAWAYCO 161.0	1	167	146.9	147.1	3.8%	Intact	XS652502>652517>\$1
635034	CLRNDA 5 161.0	560001	NODAWAYCO 161.0	1	167	146.9	147.1	3.8%	Intact	XS652517>659121>\$1
635034	CLRNDA 5 161.0	560001	NODAWAYCO 161.0	1	167	146.9	147.1	3.8%	Intact	XS652508>652551>\$1
635034	CLRNDA 5 161.0	560001	NODAWAYCO 161.0	1	167	146.9	147.1	3.8%	Intact	XS647963>647973>\$1
635034	CLRNDA 5 161.0	560001	NODAWAYCO 161.0	1	167	146.9	147.1	3.8%	Intact	XS652508>658072>\$1
635034	CLRNDA 5 161.0	560001	NODAWAYCO 161.0	1	167	146.9	147.1	3.8%	Intact	XS659133>659209>\$1
635034	CLRNDA 5 161.0	560001	NODAWAYCO 161.0	1	167	146.9	147.1	3.8%	Intact	XS652534>652432>\$1
635034	CLRNDA 5 161.0	560001	NODAWAYCO 161.0	1	167	146.9	147.1	3.8%	Intact	XS652537>652538>652293\$1

635034	CLRNDA 5 161.0	560001	NODAWAYCO 161.0	1	167	146.9	147.1	3.8%	Intact	XS652505>652474>\$1
635034	CLRNDA 5 161.0	560001	NODAWAYCO 161.0	1	167	146.9	147.1	3.8%	Intact	XS652514>652614>\$1
635034	CLRNDA 5 161.0	560001	NODAWAYCO 161.0	1	167	146.9	147.1	3.8%	Intact	XS646235>646236>\$1
635034	CLRNDA 5 161.0	560001	NODAWAYCO 161.0	1	167	146.9	147.1	3.8%	Intact	XS646234>646235>\$1
635034	CLRNDA 5 161.0	560001	NODAWAYCO 161.0	1	167	146.9	147.1	3.8%	Intact	XS652505>652524>\$1
635034	CLRNDA 5 161.0	560001	NODAWAYCO 161.0	1	167	146.9	147.1	3.8%	Intact	XS652503>652550>\$1
635034	CLRNDA 5 161.0	560001	NODAWAYCO 161.0	1	167	146.9	147.1	3.8%	Intact	XS646210>646222>\$1
635034	CLRNDA 5 161.0	560001	NODAWAYCO 161.0	1	167	146.9	147.1	3.8%	Intact	XS646250>646297>\$1
635034	CLRNDA 5 161.0	560001	NODAWAYCO 161.0	1	167	146.9	147.1	3.8%	Intact	XS652514>652530>\$2
635034	CLRNDA 5 161.0	560001	NODAWAYCO 161.0	1	167	146.9	147.1	3.8%	Intact	XS652606>652609>652608\$1
635034	CLRNDA 5 161.0	560001	NODAWAYCO 161.0	1	167	146.9	147.1	3.8%	Intact	XS650271>650285>\$1
635034	CLRNDA 5 161.0	560001	NODAWAYCO 161.0	1	167	146.9	147.1	3.8%	Intact	XS650262>650267>\$1
635034	CLRNDA 5 161.0	560001	NODAWAYCO 161.0	1	167	146.9	147.1	3.8%	Intact	XS652504>652474>\$1
635034	CLRNDA 5 161.0	560001	NODAWAYCO 161.0	1	167	146.9	147.1	3.8%	Intact	XS647424>647976>\$1
635034	CLRNDA 5 161.0	560001	NODAWAYCO 161.0	1	167	146.9	147.1	3.8%	Intact	XS659210>659209>\$1
635034	CLRNDA 5 161.0	560001	NODAWAYCO 161.0	1	167	146.9	147.1	3.8%	Intact	XS646201>646220>\$1
635034	CLRNDA 5 161.0	560001	NODAWAYCO 161.0	1	167	146.9	147.1	3.8%	Intact	XS659240>659300>\$1
635034	CLRNDA 5 161.0	560001	NODAWAYCO 161.0	1	167	146.9	147.1	3.8%	Intact	XS647969>647974>\$1
635034	CLRNDA 5 161.0	560001	NODAWAYCO 161.0	1	167	146.9	147.1	3.8%	Intact	XS650275>650284>\$1
635034	CLRNDA 5 161.0	560001	NODAWAYCO 161.0	1	167	146.9	147.1	3.8%	Intact	XS652522>652438>\$1
635034	CLRNDA 5 161.0	560001	NODAWAYCO 161.0	1	167	146.9	147.1	3.8%	Intact	XS652521>652527>\$1
635034	CLRNDA 5 161.0	560001	NODAWAYCO 161.0	1	167	146.9	147.1	3.8%	Intact	XS647106>647923>\$1
635034	CLRNDA 5 161.0	560001	NODAWAYCO 161.0	1	167	146.9	147.1	3.8%	Intact	XS647965>647975>\$1
635034	CLRNDA 5 161.0	560001	NODAWAYCO 161.0	1	167	146.9	147.1	3.8%	Intact	XS647014>647846>\$1
635034	CLRNDA 5 161.0	560001	NODAWAYCO 161.0	1	167	146.9	147.1	3.8%	Intact	XS646201>647901>648201\$1

635034	CLRND 5 161.0	560001	NODAWAYCO 161.0	1	167	146.9	147.1	3.8%	Intact	XS647907>647911>\$1
635034	CLRND 5 161.0	560001	NODAWAYCO 161.0	1	167	146.9	147.1	3.8%	Intact	XS652523>602004>\$1
635034	CLRND 5 161.0	560001	NODAWAYCO 161.0	1	167	146.9	147.1	3.8%	Intact	XS647968>647969>\$1
635034	CLRND 5 161.0	560001	NODAWAYCO 161.0	1	167	146.9	147.1	3.8%	Intact	XS645127>646211>\$1
635034	CLRND 5 161.0	560001	NODAWAYCO 161.0	1	167	146.9	147.1	3.8%	Intact	XS652550>652554>\$1
635034	CLRND 5 161.0	560001	NODAWAYCO 161.0	1	167	146.9	147.1	3.8%	Intact	XS652519>652520>\$1
635034	CLRND 5 161.0	560001	NODAWAYCO 161.0	1	167	146.9	147.1	3.8%	Intact	XS659154>659188>\$1
635034	CLRND 5 161.0	560001	NODAWAYCO 161.0	1	167	146.9	147.1	3.8%	Intact	XS652518>659123>\$1
635034	CLRND 5 161.0	560001	NODAWAYCO 161.0	1	167	146.9	147.1	3.8%	Intact	XS652398>652523>\$1
635034	CLRND 5 161.0	560001	NODAWAYCO 161.0	1	167	146.9	147.1	3.8%	Intact	XS647090>647982>\$1
635034	CLRND 5 161.0	560001	NODAWAYCO 161.0	1	167	146.9	147.1	3.8%	Intact	XS645126>647911>\$1
635034	CLRND 5 161.0	560001	NODAWAYCO 161.0	1	167	146.9	147.1	3.8%	Intact	XS646286>646299>\$1
635034	CLRND 5 161.0	560001	NODAWAYCO 161.0	1	167	146.9	147.1	3.8%	Intact	XS646217>647917>648217\$1
635034	CLRND 5 161.0	560001	NODAWAYCO 161.0	1	167	146.9	147.1	3.8%	Intact	XS647014>647914>\$1
635034	CLRND 5 161.0	560001	NODAWAYCO 161.0	1	167	146.9	147.1	3.8%	Intact	XS652398>652526>\$1
635034	CLRND 5 161.0	560001	NODAWAYCO 161.0	1	167	146.9	147.1	3.8%	Intact	XS652527>661038>\$1
635034	CLRND 5 161.0	560001	NODAWAYCO 161.0	1	167	146.9	147.1	3.8%	Intact	XS652463>652510>\$1
635034	CLRND 5 161.0	560001	NODAWAYCO 161.0	1	167	146.9	147.1	3.8%	Intact	XS652463>652525>\$1
635034	CLRND 5 161.0	560001	NODAWAYCO 161.0	1	167	146.9	147.1	3.8%	Intact	XS300122>300123>\$1
635034	CLRND 5 161.0	560001	NODAWAYCO 161.0	1	167	146.9	147.1	3.8%	Intact	CB1231-09&35
635034	CLRND 5 161.0	560001	NODAWAYCO 161.0	1	167	146.9	147.1	3.8%	Intact	XS532771>533416>532807\$1
635034	CLRND 5 161.0	560001	NODAWAYCO 161.0	1	167	146.9	147.1	3.8%	Intact	XS300120>300172>\$2
635034	CLRND 5 161.0	560001	NODAWAYCO 161.0	1	167	146.9	147.1	3.8%	Intact	XS532771>532796>\$1
635034	CLRND 5 161.0	560001	NODAWAYCO 161.0	1	167	146.9	147.1	3.8%	Intact	XS300120>300172>\$1
635034	CLRND 5 161.0	560001	NODAWAYCO 161.0	1	167	146.9	147.1	3.8%	Intact	XS300080>301015>\$1

635034	CLRNDA 5 161.0	560001	NODAWAYCO 161.0	1	167	146.9	147.1	3.8%	Intact	XS300120>300126>\$1
635034	CLRNDA 5 161.0	560001	NODAWAYCO 161.0	1	167	146.9	147.1	3.8%	Intact	CB917-BUS
635034	CLRNDA 5 161.0	560001	NODAWAYCO 161.0	1	167	146.9	147.1	3.8%	Intact	XS300129>300763>\$1
635034	CLRNDA 5 161.0	560001	NODAWAYCO 161.0	1	167	146.9	147.1	3.8%	Intact	XS300069>300741>\$1
635034	CLRNDA 5 161.0	560001	NODAWAYCO 161.0	1	167	146.9	147.1	3.8%	Intact	XS300593>344773>\$1
635034	CLRNDA 5 161.0	560001	NODAWAYCO 161.0	1	167	146.9	147.1	3.8%	Intact	XS300070>300793>\$1
635034	CLRNDA 5 161.0	560001	NODAWAYCO 161.0	1	167	146.9	147.1	3.8%	Intact	XS300595>345498>\$1
635034	CLRNDA 5 161.0	560001	NODAWAYCO 161.0	1	167	146.9	147.1	3.8%	Intact	CB923-12-PXM
635034	CLRNDA 5 161.0	560001	NODAWAYCO 161.0	1	167	146.9	147.1	3.8%	Intact	XS532791>532796>\$1
635034	CLRNDA 5 161.0	560001	NODAWAYCO 161.0	1	167	146.9	147.1	3.8%	Intact	XS532791>532794>\$1
635034	CLRNDA 5 161.0	560001	NODAWAYCO 161.0	1	167	146.9	147.1	3.8%	Intact	XS532780>532800>\$1
635034	CLRNDA 5 161.0	560001	NODAWAYCO 161.0	1	167	146.9	147.1	3.8%	Intact	XS300074>301138>\$1
635034	CLRNDA 5 161.0	560001	NODAWAYCO 161.0	1	167	146.9	147.1	3.8%	Intact	XS532774>532856>532819\$2
635034	CLRNDA 5 161.0	560001	NODAWAYCO 161.0	1	167	146.9	147.1	3.8%	Intact	XS300075>505434>\$1
635034	CLRNDA 5 161.0	560001	NODAWAYCO 161.0	1	167	146.9	147.1	3.8%	Intact	XS300597>300602>\$1
635034	CLRNDA 5 161.0	560001	NODAWAYCO 161.0	1	167	146.9	147.1	3.8%	Intact	XS300092>301070>\$1
635034	CLRNDA 5 161.0	560001	NODAWAYCO 161.0	1	167	146.9	147.1	3.8%	Intact	XS301144>344360>\$1
635034	CLRNDA 5 161.0	560001	NODAWAYCO 161.0	1	167	146.9	147.1	3.8%	Intact	XS300094>300278>\$1
635034	CLRNDA 5 161.0	560001	NODAWAYCO 161.0	1	167	146.9	147.1	3.8%	Intact	XS301161>549970>\$1
635034	CLRNDA 5 161.0	560001	NODAWAYCO 161.0	1	167	146.9	147.1	3.8%	Intact	XS300606>344480>\$1
635034	CLRNDA 5 161.0	560001	NODAWAYCO 161.0	1	167	146.9	147.1	3.8%	Intact	XS300740>512650>\$1
635034	CLRNDA 5 161.0	560001	NODAWAYCO 161.0	1	167	146.9	147.1	3.8%	Intact	CB906S69BSC2
635034	CLRNDA 5 161.0	560001	NODAWAYCO 161.0	1	167	146.9	147.1	3.8%	Intact	XS300112>301015>\$1
635034	CLRNDA 5 161.0	560001	NODAWAYCO 161.0	1	167	146.9	147.1	3.8%	Intact	MC1209-1231
635034	CLRNDA 5 161.0	560001	NODAWAYCO 161.0	1	167	146.9	147.1	3.8%	Intact	XS301344>512655>\$1

635034	CLRNDA 5 161.0	560001	NODAWAYCO 161.0	1	167	146.9	147.1	3.8%	Intact	XS300091>300302>\$1
635034	CLRNDA 5 161.0	560001	NODAWAYCO 161.0	1	167	146.9	147.1	3.8%	Intact	XS300093>301211>\$1
635034	CLRNDA 5 161.0	560001	NODAWAYCO 161.0	1	167	146.9	147.1	3.8%	Intact	LES7101
635034	CLRNDA 5 161.0	560001	NODAWAYCO 161.0	1	167	146.9	147.1	3.8%	Intact	LES7102
635034	CLRNDA 5 161.0	560001	NODAWAYCO 161.0	1	167	146.9	147.1	3.8%	Intact	LES7103
635034	CLRNDA 5 161.0	560001	NODAWAYCO 161.0	1	167	146.9	147.1	3.8%	Intact	XS300095>301057>\$1
635034	CLRNDA 5 161.0	560001	NODAWAYCO 161.0	1	167	146.9	147.1	3.8%	Intact	XS300106>300364>\$1
635034	CLRNDA 5 161.0	560001	NODAWAYCO 161.0	1	167	146.9	147.1	3.8%	Intact	XS300095>301161>\$1
635034	CLRNDA 5 161.0	560001	NODAWAYCO 161.0	1	167	146.9	147.1	3.8%	Intact	XS301057>301070>\$1
635034	CLRNDA 5 161.0	560001	NODAWAYCO 161.0	1	167	146.9	147.1	3.8%	Intact	CB906N69B916
635034	CLRNDA 5 161.0	560001	NODAWAYCO 161.0	1	167	146.9	147.1	3.8%	Intact	CB906N69CBUS
635034	CLRNDA 5 161.0	560001	NODAWAYCO 161.0	1	167	146.9	147.1	3.8%	Intact	CB901-JS&BUS
635034	CLRNDA 5 161.0	560001	NODAWAYCO 161.0	1	167	146.9	147.1	3.8%	Intact	MC1211-1250
635034	CLRNDA 5 161.0	560001	NODAWAYCO 161.0	1	167	146.9	147.1	3.8%	Intact	XS532766>532852>532806\$1
635034	CLRNDA 5 161.0	560001	NODAWAYCO 161.0	1	167	146.9	147.1	3.8%	Intact	XS300084>505440>\$1
635034	CLRNDA 5 161.0	560001	NODAWAYCO 161.0	1	167	146.9	147.1	3.8%	Intact	XS300617>300637>\$1
635034	CLRNDA 5 161.0	560001	NODAWAYCO 161.0	1	167	146.9	147.1	3.8%	Intact	CB1253-35&37
635034	CLRNDA 5 161.0	560001	NODAWAYCO 161.0	1	167	146.9	147.1	3.8%	Intact	XS532766>532852>532805\$1
635034	CLRNDA 5 161.0	560001	NODAWAYCO 161.0	1	167	146.9	147.1	3.8%	Intact	XS300608>300609>\$1
635034	CLRNDA 5 161.0	560001	NODAWAYCO 161.0	1	167	146.9	147.1	3.8%	Intact	XS300083>300103>\$1
635034	CLRNDA 5 161.0	560001	NODAWAYCO 161.0	1	167	146.9	147.1	3.8%	Intact	LES0010A
635034	CLRNDA 5 161.0	560001	NODAWAYCO 161.0	1	167	146.9	147.1	3.8%	Intact	CB914A-88-T1
635034	CLRNDA 5 161.0	560001	NODAWAYCO 161.0	1	167	146.9	147.1	3.8%	Intact	XS300081>300095>\$1
635034	CLRNDA 5 161.0	560001	NODAWAYCO 161.0	1	167	146.9	147.1	3.8%	Intact	LES1404
635034	CLRNDA 5 161.0	560001	NODAWAYCO 161.0	1	167	146.9	147.1	3.8%	Intact	XS300113>300349>\$1

635034	CLRNDA 5 161.0	560001	NODAWAYCO 161.0	1	167	146.9	147.1	3.8%	Intact	LES1403
635034	CLRNDA 5 161.0	560001	NODAWAYCO 161.0	1	167	146.9	147.1	3.8%	Intact	XS300113>300349>\$2
635034	CLRNDA 5 161.0	560001	NODAWAYCO 161.0	1	167	146.9	147.1	3.8%	Intact	XS300086>301062>\$1
635034	CLRNDA 5 161.0	560001	NODAWAYCO 161.0	1	167	146.9	147.1	3.8%	Intact	XS300118>505498>\$1
635034	CLRNDA 5 161.0	560001	NODAWAYCO 161.0	1	167	146.9	147.1	3.8%	Intact	XS300059>300597>\$1
635034	CLRNDA 5 161.0	560001	NODAWAYCO 161.0	1	167	146.9	147.1	3.8%	Intact	BKR-PLN-3310
635034	CLRNDA 5 161.0	560001	NODAWAYCO 161.0	1	167	146.9	147.1	3.8%	Intact	S993 GEN OFF
635034	CLRNDA 5 161.0	560001	NODAWAYCO 161.0	1	167	146.9	147.1	3.8%	Intact	CB975-T4-993
635034	CLRNDA 5 161.0	560001	NODAWAYCO 161.0	1	167	146.9	147.1	3.8%	Intact	XS300059>300099>\$1
635034	CLRNDA 5 161.0	560001	NODAWAYCO 161.0	1	167	146.9	147.1	3.8%	Intact	XS300057>300618>\$1
635034	CLRNDA 5 161.0	560001	NODAWAYCO 161.0	1	167	146.9	147.1	3.8%	Intact	XS532856>532857>\$1
635034	CLRNDA 5 161.0	560001	NODAWAYCO 161.0	1	167	146.9	147.1	3.8%	Intact	XS300136>514906>\$1
635034	CLRNDA 5 161.0	560001	NODAWAYCO 161.0	1	167	146.9	147.1	3.8%	Intact	XS300040>300047>\$1
635034	CLRNDA 5 161.0	560001	NODAWAYCO 161.0	1	167	146.9	147.1	3.8%	Intact	XS300135>300136>\$1
635034	CLRNDA 5 161.0	560001	NODAWAYCO 161.0	1	167	146.9	147.1	3.8%	Intact	S976-FRE-D-E
635034	CLRNDA 5 161.0	560001	NODAWAYCO 161.0	1	167	146.9	147.1	3.8%	Intact	S973NOBKR
635034	CLRNDA 5 161.0	560001	NODAWAYCO 161.0	1	167	146.9	147.1	3.8%	Intact	XS300061>343014>\$1
635034	CLRNDA 5 161.0	560001	NODAWAYCO 161.0	1	167	146.9	147.1	3.8%	Intact	XS300500>345409>\$1
635034	CLRNDA 5 161.0	560001	NODAWAYCO 161.0	1	167	146.9	147.1	3.8%	Intact	XS532871>533413>532892\$1
635034	CLRNDA 5 161.0	560001	NODAWAYCO 161.0	1	167	146.9	147.1	3.8%	Intact	CBFREM-D-C-B
635034	CLRNDA 5 161.0	560001	NODAWAYCO 161.0	1	167	146.9	147.1	3.8%	Intact	XS300053>300096>\$1
635034	CLRNDA 5 161.0	560001	NODAWAYCO 161.0	1	167	146.9	147.1	3.8%	Intact	XS300053>345024>\$1
635034	CLRNDA 5 161.0	560001	NODAWAYCO 161.0	1	167	146.9	147.1	3.8%	Intact	XS300055>300060>\$1
635034	CLRNDA 5 161.0	560001	NODAWAYCO 161.0	1	167	146.9	147.1	3.8%	Intact	XS300140>300141>\$1
635034	CLRNDA 5 161.0	560001	NODAWAYCO 161.0	1	167	146.9	147.1	3.8%	Intact	BKR-GRI-1396

635034	CLRNDA 5 161.0	560001	NODAWAYCO 161.0	1	167	146.9	147.1	3.8%	Intact	XS300055>300609>\$1
635034	CLRNDA 5 161.0	560001	NODAWAYCO 161.0	1	167	146.9	147.1	3.8%	Intact	XS300038>300075>\$1
635034	CLRNDA 5 161.0	560001	NODAWAYCO 161.0	1	167	146.9	147.1	3.8%	Intact	XS300129>505486>\$1
635034	CLRNDA 5 161.0	560001	NODAWAYCO 161.0	1	167	146.9	147.1	3.8%	Intact	XS532857>533182>532886\$1
635034	CLRNDA 5 161.0	560001	NODAWAYCO 161.0	1	167	146.9	147.1	3.8%	Intact	XS532856>532863>\$1
635034	CLRNDA 5 161.0	560001	NODAWAYCO 161.0	1	167	146.9	147.1	3.8%	Intact	XS300066>300120>\$1
635034	CLRNDA 5 161.0	560001	NODAWAYCO 161.0	1	167	146.9	147.1	3.8%	Intact	XS300066>300508>\$1
635034	CLRNDA 5 161.0	560001	NODAWAYCO 161.0	1	167	146.9	147.1	3.8%	Intact	CB968-67-TEC
635034	CLRNDA 5 161.0	560001	NODAWAYCO 161.0	1	167	146.9	147.1	3.8%	Intact	XS300063>300550>\$1
635034	CLRNDA 5 161.0	560001	NODAWAYCO 161.0	1	167	146.9	147.1	3.8%	Intact	XS300134>300593>\$1
635034	CLRNDA 5 161.0	560001	NODAWAYCO 161.0	1	167	146.9	147.1	3.8%	Intact	XS300063>344233>\$1
635034	CLRNDA 5 161.0	560001	NODAWAYCO 161.0	1	167	146.9	147.1	3.8%	Intact	XS541340>541290>\$1
635034	CLRNDA 5 161.0	560001	NODAWAYCO 161.0	1	167	146.9	147.1	3.8%	Intact	XS541200>541225>541361\$1
635034	CLRNDA 5 161.0	560001	NODAWAYCO 161.0	1	167	146.9	147.1	3.8%	Intact	XS543038>543052>\$1
635034	CLRNDA 5 161.0	560001	NODAWAYCO 161.0	1	167	146.9	147.1	3.8%	Intact	XS533413>533419>\$1
635034	CLRNDA 5 161.0	560001	NODAWAYCO 161.0	1	167	146.9	147.1	3.8%	Intact	XS533244>533249>\$1
635034	CLRNDA 5 161.0	560001	NODAWAYCO 161.0	1	167	146.9	147.1	3.8%	Intact	XS541259>541382>\$1
635034	CLRNDA 5 161.0	560001	NODAWAYCO 161.0	1	167	146.9	147.1	3.8%	Intact	XS541314>541315>\$1
635034	CLRNDA 5 161.0	560001	NODAWAYCO 161.0	1	167	146.9	147.1	3.8%	Intact	XS631013>631017>\$1
635034	CLRNDA 5 161.0	560001	NODAWAYCO 161.0	1	167	146.9	147.1	3.8%	Intact	XS541200>541201>\$1
635034	CLRNDA 5 161.0	560001	NODAWAYCO 161.0	1	167	146.9	147.1	3.8%	Intact	XS631015>631016>\$1
635034	CLRNDA 5 161.0	560001	NODAWAYCO 161.0	1	167	146.9	147.1	3.8%	Intact	XS631041>658066>\$2
635034	CLRNDA 5 161.0	560001	NODAWAYCO 161.0	1	167	146.9	147.1	3.8%	Intact	XS631079>630007>\$1
635034	CLRNDA 5 161.0	560001	NODAWAYCO 161.0	1	167	146.9	147.1	3.8%	Intact	XS543041>546651>\$1
635034	CLRNDA 5 161.0	560001	NODAWAYCO 161.0	1	167	146.9	147.1	3.8%	Intact	XS533002>533688>533089\$1

635034	CLRNDA 5 161.0	560001	NODAWAYCO 161.0	1	167	146.9	147.1	3.8%	Intact	XS631057>631061>\$1
635034	CLRNDA 5 161.0	560001	NODAWAYCO 161.0	1	167	146.9	147.1	3.8%	Intact	XS533326>533335>\$1
635034	CLRNDA 5 161.0	560001	NODAWAYCO 161.0	1	167	146.9	147.1	3.8%	Intact	XS631040>631041>\$1
635034	CLRNDA 5 161.0	560001	NODAWAYCO 161.0	1	167	146.9	147.1	3.8%	Intact	XS533002>533004>\$1
635034	CLRNDA 5 161.0	560001	NODAWAYCO 161.0	1	167	146.9	147.1	3.8%	Intact	XS541198>541342>541372\$1
635034	CLRNDA 5 161.0	560001	NODAWAYCO 161.0	1	167	146.9	147.1	3.8%	Intact	XS543036>543046>\$1
635034	CLRNDA 5 161.0	560001	NODAWAYCO 161.0	1	167	146.9	147.1	3.8%	Intact	XS543036>543048>\$1
635034	CLRNDA 5 161.0	560001	NODAWAYCO 161.0	1	167	146.9	147.1	3.8%	Intact	XS541259>541340>\$1
635034	CLRNDA 5 161.0	560001	NODAWAYCO 161.0	1	167	146.9	147.1	3.8%	Intact	XS631062>631097>\$1
635034	CLRNDA 5 161.0	560001	NODAWAYCO 161.0	1	167	146.9	147.1	3.8%	Intact	XS542973>542997>\$1
635034	CLRNDA 5 161.0	560001	NODAWAYCO 161.0	1	167	146.9	147.1	3.8%	Intact	XS631064>631065>\$1
635034	CLRNDA 5 161.0	560001	NODAWAYCO 161.0	1	167	146.9	147.1	3.8%	Intact	XS631066>630177>\$1
635034	CLRNDA 5 161.0	560001	NODAWAYCO 161.0	1	167	146.9	147.1	3.8%	Intact	XS533253>533271>\$1
635034	CLRNDA 5 161.0	560001	NODAWAYCO 161.0	1	167	146.9	147.1	3.8%	Intact	XS543062>345221>\$1
635034	CLRNDA 5 161.0	560001	NODAWAYCO 161.0	1	167	146.9	147.1	3.8%	Intact	XS533419>533440>\$1
635034	CLRNDA 5 161.0	560001	NODAWAYCO 161.0	1	167	146.9	147.1	3.8%	Intact	XS631017>631022>\$1
635034	CLRNDA 5 161.0	560001	NODAWAYCO 161.0	1	167	146.9	147.1	3.8%	Intact	XS543063>543094>\$1
635034	CLRNDA 5 161.0	560001	NODAWAYCO 161.0	1	167	146.9	147.1	3.8%	Intact	XS533039>533042>\$1
635034	CLRNDA 5 161.0	560001	NODAWAYCO 161.0	1	167	146.9	147.1	3.8%	Intact	XS533180>533182>\$1
635034	CLRNDA 5 161.0	560001	NODAWAYCO 161.0	1	167	146.9	147.1	3.8%	Intact	XS542973>542997>\$2
635034	CLRNDA 5 161.0	560001	NODAWAYCO 161.0	1	167	146.9	147.1	3.8%	Intact	XS533042>533063>\$1
635034	CLRNDA 5 161.0	560001	NODAWAYCO 161.0	1	167	146.9	147.1	3.8%	Intact	XS533415>533506>533444\$1
635034	CLRNDA 5 161.0	560001	NODAWAYCO 161.0	1	167	146.9	147.1	3.8%	Intact	XS542973>543020>\$1
635034	CLRNDA 5 161.0	560001	NODAWAYCO 161.0	1	167	146.9	147.1	3.8%	Intact	XS533440>533455>\$1
635034	CLRNDA 5 161.0	560001	NODAWAYCO 161.0	1	167	146.9	147.1	3.8%	Intact	XS533328>533335>\$1

635034	CLRNDA 5 161.0	560001	NODAWAYCO 161.0	1	167	146.9	147.1	3.8%	Intact	XS631016>631080>\$1
635034	CLRNDA 5 161.0	560001	NODAWAYCO 161.0	1	167	146.9	147.1	3.8%	Intact	XS533040>533041>\$1
635034	CLRNDA 5 161.0	560001	NODAWAYCO 161.0	1	167	146.9	147.1	3.8%	Intact	XS631042>658066>\$2
635034	CLRNDA 5 161.0	560001	NODAWAYCO 161.0	1	167	146.9	147.1	3.8%	Intact	XS533417>533427>\$1
635034	CLRNDA 5 161.0	560001	NODAWAYCO 161.0	1	167	146.9	147.1	3.8%	Intact	XS533435>533527>533446\$1
635034	CLRNDA 5 161.0	560001	NODAWAYCO 161.0	1	167	146.9	147.1	3.8%	Intact	XS631084>631108>\$1
635034	CLRNDA 5 161.0	560001	NODAWAYCO 161.0	1	167	146.9	147.1	3.8%	Intact	XS542998>541220>\$1
635034	CLRNDA 5 161.0	560001	NODAWAYCO 161.0	1	167	146.9	147.1	3.8%	Intact	XS541225>541243>\$1
635034	CLRNDA 5 161.0	560001	NODAWAYCO 161.0	1	167	146.9	147.1	3.8%	Intact	XS541214>541160>\$1
635034	CLRNDA 5 161.0	560001	NODAWAYCO 161.0	1	167	146.9	147.1	3.8%	Intact	XS542997>543010>\$1
635034	CLRNDA 5 161.0	560001	NODAWAYCO 161.0	1	167	146.9	147.1	3.8%	Intact	XS631004>631013>\$1
635034	CLRNDA 5 161.0	560001	NODAWAYCO 161.0	1	167	146.9	147.1	3.8%	Intact	XS533170>533171>\$1
635034	CLRNDA 5 161.0	560001	NODAWAYCO 161.0	1	167	146.9	147.1	3.8%	Intact	XS533341>533345>\$1
635034	CLRNDA 5 161.0	560001	NODAWAYCO 161.0	1	167	146.9	147.1	3.8%	Intact	XS631055>631120>\$1
635034	CLRNDA 5 161.0	560001	NODAWAYCO 161.0	1	167	146.9	147.1	3.8%	Intact	XS533164>533165>\$1
635034	CLRNDA 5 161.0	560001	NODAWAYCO 161.0	1	167	146.9	147.1	3.8%	Intact	XS541213>541214>\$1
635034	CLRNDA 5 161.0	560001	NODAWAYCO 161.0	1	167	146.9	147.1	3.8%	Intact	XS541224>541249>\$1
635034	CLRNDA 5 161.0	560001	NODAWAYCO 161.0	1	167	146.9	147.1	3.8%	Intact	XS541218>541313>\$1
635034	CLRNDA 5 161.0	560001	NODAWAYCO 161.0	1	167	146.9	147.1	3.8%	Intact	XS631003>631010>\$1
635034	CLRNDA 5 161.0	560001	NODAWAYCO 161.0	1	167	146.9	147.1	3.8%	Intact	XS631034>631092>\$1
635034	CLRNDA 5 161.0	560001	NODAWAYCO 161.0	1	167	146.9	147.1	3.8%	Intact	XS542998>543009>\$1
635034	CLRNDA 5 161.0	560001	NODAWAYCO 161.0	1	167	146.9	147.1	3.8%	Intact	XS631034>631093>\$1
635034	CLRNDA 5 161.0	560001	NODAWAYCO 161.0	1	167	146.9	147.1	3.8%	Intact	XS542999>541317>\$1
635034	CLRNDA 5 161.0	560001	NODAWAYCO 161.0	1	167	146.9	147.1	3.8%	Intact	XS533182>533884>\$1
635034	CLRNDA 5 161.0	560001	NODAWAYCO 161.0	1	167	146.9	147.1	3.8%	Intact	XS541214>541230>\$1

635034	CLRNDA 5 161.0	560001	NODAWAYCO 161.0	1	167	146.9	147.1	3.8%	Intact	XS543021>543025>\$1
635034	CLRNDA 5 161.0	560001	NODAWAYCO 161.0	1	167	146.9	147.1	3.8%	Intact	XS533342>533343>\$1
635034	CLRNDA 5 161.0	560001	NODAWAYCO 161.0	1	167	146.9	147.1	3.8%	Intact	XS541214>541161>\$1
635034	CLRNDA 5 161.0	560001	NODAWAYCO 161.0	1	167	146.9	147.1	3.8%	Intact	XS631001>631012>\$1
635034	CLRNDA 5 161.0	560001	NODAWAYCO 161.0	1	167	146.9	147.1	3.8%	Intact	XS543034>543052>\$1
635034	CLRNDA 5 161.0	560001	NODAWAYCO 161.0	1	167	146.9	147.1	3.8%	Intact	XS533335>533341>\$1
635034	CLRNDA 5 161.0	560001	NODAWAYCO 161.0	1	167	146.9	147.1	3.8%	Intact	XS631057>631120>\$1
635034	CLRNDA 5 161.0	560001	NODAWAYCO 161.0	1	167	146.9	147.1	3.8%	Intact	XS631080>631182>\$1
635034	CLRNDA 5 161.0	560001	NODAWAYCO 161.0	1	167	146.9	147.1	3.8%	Intact	XS541207>541341>\$1
635034	CLRNDA 5 161.0	560001	NODAWAYCO 161.0	1	167	146.9	147.1	3.8%	Intact	XS543033>543047>\$1
635034	CLRNDA 5 161.0	560001	NODAWAYCO 161.0	1	167	146.9	147.1	3.8%	Intact	XS631059>681520>\$1
635034	CLRNDA 5 161.0	560001	NODAWAYCO 161.0	1	167	146.9	147.1	3.8%	Intact	XS541243>541249>\$1
635034	CLRNDA 5 161.0	560001	NODAWAYCO 161.0	1	167	146.9	147.1	3.8%	Intact	XS541203>541247>\$1
635034	CLRNDA 5 161.0	560001	NODAWAYCO 161.0	1	167	146.9	147.1	3.8%	Intact	XS631079>631121>\$1
635034	CLRNDA 5 161.0	560001	NODAWAYCO 161.0	1	167	146.9	147.1	3.8%	Intact	XS631080>631088>\$1
635034	CLRNDA 5 161.0	560001	NODAWAYCO 161.0	1	167	146.9	147.1	3.8%	Intact	XS631082>631128>\$1
635034	CLRNDA 5 161.0	560001	NODAWAYCO 161.0	1	167	146.9	147.1	3.8%	Intact	XS631056>631060>\$1
635034	CLRNDA 5 161.0	560001	NODAWAYCO 161.0	1	167	146.9	147.1	3.8%	Intact	XS533217>533337>\$1
635034	CLRNDA 5 161.0	560001	NODAWAYCO 161.0	1	167	146.9	147.1	3.8%	Intact	XS542995>541245>\$1
635034	CLRNDA 5 161.0	560001	NODAWAYCO 161.0	1	167	146.9	147.1	3.8%	Intact	XS631048>656201>\$1
635034	CLRNDA 5 161.0	560001	NODAWAYCO 161.0	1	167	146.9	147.1	3.8%	Intact	XS541232>541264>\$1
635034	CLRNDA 5 161.0	560001	NODAWAYCO 161.0	1	167	146.9	147.1	3.8%	Intact	XS533371>533381>\$1
635034	CLRNDA 5 161.0	560001	NODAWAYCO 161.0	1	167	146.9	147.1	3.8%	Intact	XS542995>541207>\$1
635034	CLRNDA 5 161.0	560001	NODAWAYCO 161.0	1	167	146.9	147.1	3.8%	Intact	XS542993>543010>\$1
635034	CLRNDA 5 161.0	560001	NODAWAYCO 161.0	1	167	146.9	147.1	3.8%	Intact	XS631038>602039>\$1

635034	CLRND 5 161.0	560001	NODAWAYCO 161.0	1	167	146.9	147.1	3.8%	Intact	XS532984>533063>\$1
635034	CLRND 5 161.0	560001	NODAWAYCO 161.0	1	167	146.8	147	3.8%	Intact	XS635653>635654>\$1
635034	CLRND 5 161.0	560001	NODAWAYCO 161.0	1	167	146.8	147	3.8%	Intact	XS636635>636636>\$1
635034	CLRND 5 161.0	560001	NODAWAYCO 161.0	1	167	146.8	147	3.8%	Intact	XS635680>635700>\$1
635034	CLRND 5 161.0	560001	NODAWAYCO 161.0	1	167	146.8	147	3.8%	Intact	XS645001>645102>\$1
635034	CLRND 5 161.0	560001	NODAWAYCO 161.0	1	167	146.8	147	3.8%	Intact	XS640287>640365>\$1
635034	CLRND 5 161.0	560001	NODAWAYCO 161.0	1	167	146.8	147	3.8%	Intact	XS640281>648401>\$1
635034	CLRND 5 161.0	560001	NODAWAYCO 161.0	1	167	146.8	147	3.8%	Intact	XS640281>648400>\$1
635034	CLRND 5 161.0	560001	NODAWAYCO 161.0	1	167	146.8	147	3.8%	Intact	XS635610>635612>\$1
635034	CLRND 5 161.0	560001	NODAWAYCO 161.0	1	167	146.8	147	3.8%	Intact	XS635612>635613>\$1
635034	CLRND 5 161.0	560001	NODAWAYCO 161.0	1	167	146.8	147	3.8%	Intact	XS641082>641091>\$1
635034	CLRND 5 161.0	560001	NODAWAYCO 161.0	1	167	146.8	147	3.8%	Intact	XS631094>629098>\$1
635034	CLRND 5 161.0	560001	NODAWAYCO 161.0	1	167	146.8	147	3.8%	Intact	XS640411>640443>\$1
635034	CLRND 5 161.0	560001	NODAWAYCO 161.0	1	167	146.8	147	3.8%	Intact	XS640161>640162>\$1
635034	CLRND 5 161.0	560001	NODAWAYCO 161.0	1	167	146.8	147	3.8%	Intact	XS640167>640168>\$1
635034	CLRND 5 161.0	560001	NODAWAYCO 161.0	1	167	146.8	147	3.8%	Intact	XS647985>640320>\$1
635034	CLRND 5 161.0	560001	NODAWAYCO 161.0	1	167	146.8	147	3.8%	Intact	XS647112>647993>\$1
635034	CLRND 5 161.0	560001	NODAWAYCO 161.0	1	167	146.8	147	3.8%	Intact	XS647112>647964>\$1
635034	CLRND 5 161.0	560001	NODAWAYCO 161.0	1	167	146.8	147	3.8%	Intact	XS647091>647427>\$1
635034	CLRND 5 161.0	560001	NODAWAYCO 161.0	1	167	146.8	147	3.8%	Intact	XS652535>652291>\$1
635034	CLRND 5 161.0	560001	NODAWAYCO 161.0	1	167	146.8	147	3.8%	Intact	XS652503>652530>\$1
635034	CLRND 5 161.0	560001	NODAWAYCO 161.0	1	167	146.8	147	3.8%	Intact	XS646206>647906>648206\$1
635034	CLRND 5 161.0	560001	NODAWAYCO 161.0	1	167	146.8	147	3.8%	Intact	XS650284>650384>650584\$1
635034	CLRND 5 161.0	560001	NODAWAYCO 161.0	1	167	146.8	147	3.8%	Intact	XS646201>646229>\$1
635034	CLRND 5 161.0	560001	NODAWAYCO 161.0	1	167	146.8	147	3.8%	Intact	XS300077>345798>\$1

635034	CLRND 5 161.0	560001	NODAWAYCO 161.0	1	167	146.8	147	3.8%	Intact	XS300080>301076>\$1
635034	CLRND 5 161.0	560001	NODAWAYCO 161.0	1	167	146.8	147	3.8%	Intact	CB1206-T2SC3
635034	CLRND 5 161.0	560001	NODAWAYCO 161.0	1	167	146.8	147	3.8%	Intact	CB914A-14-88
635034	CLRND 5 161.0	560001	NODAWAYCO 161.0	1	167	146.8	147	3.8%	Intact	LES0015
635034	CLRND 5 161.0	560001	NODAWAYCO 161.0	1	167	146.8	147	3.8%	Intact	XS300088>300102>\$1
635034	CLRND 5 161.0	560001	NODAWAYCO 161.0	1	167	146.8	147	3.8%	Intact	CB909-BUS
635034	CLRND 5 161.0	560001	NODAWAYCO 161.0	1	167	146.8	147	3.8%	Intact	XS300045>549984>\$1
635034	CLRND 5 161.0	560001	NODAWAYCO 161.0	1	167	146.8	147	3.8%	Intact	XS532851>532856>\$1
635034	CLRND 5 161.0	560001	NODAWAYCO 161.0	1	167	146.8	147	3.8%	Intact	CB1201-29&86
635034	CLRND 5 161.0	560001	NODAWAYCO 161.0	1	167	146.8	147	3.8%	Intact	XS300047>300112>\$1
635034	CLRND 5 161.0	560001	NODAWAYCO 161.0	1	167	146.8	147	3.8%	Intact	BKR-MOR-3304
635034	CLRND 5 161.0	560001	NODAWAYCO 161.0	1	167	146.8	147	3.8%	Intact	CBFREM-G
635034	CLRND 5 161.0	560001	NODAWAYCO 161.0	1	167	146.8	147	3.8%	Intact	S1206T2 BSCL
635034	CLRND 5 161.0	560001	NODAWAYCO 161.0	1	167	146.8	147	3.8%	Intact	CB1206-32&T1
635034	CLRND 5 161.0	560001	NODAWAYCO 161.0	1	167	146.8	147	3.8%	Intact	XS533002>510422>\$1
635034	CLRND 5 161.0	560001	NODAWAYCO 161.0	1	167	146.8	147	3.8%	Intact	XS541202>541250>\$1
635034	CLRND 5 161.0	560001	NODAWAYCO 161.0	1	167	146.8	147	3.8%	Intact	XS631021>631022>\$1
635034	CLRND 5 161.0	560001	NODAWAYCO 161.0	1	167	146.8	147	3.8%	Intact	XS541201>541202>541360\$1
635034	CLRND 5 161.0	560001	NODAWAYCO 161.0	1	167	146.8	147	3.8%	Intact	XS631021>629096>\$1
635034	CLRND 5 161.0	560001	NODAWAYCO 161.0	1	167	146.8	147	3.8%	Intact	XS542968>542969>543647\$11
635034	CLRND 5 161.0	560001	NODAWAYCO 161.0	1	167	146.8	147	3.8%	Intact	XS542973>543027>\$1
635034	CLRND 5 161.0	560001	NODAWAYCO 161.0	1	167	146.8	147	3.8%	Intact	XS542968>542969>543648\$22
635034	CLRND 5 161.0	560001	NODAWAYCO 161.0	1	167	146.8	147	3.8%	Intact	XS542969>542994>\$1
635034	CLRND 5 161.0	560001	NODAWAYCO 161.0	1	167	146.8	147	3.8%	Intact	XS631073>631092>\$1
635034	CLRND 5 161.0	560001	NODAWAYCO 161.0	1	167	146.8	147	3.8%	Intact	XS542978>543039>\$1

635034	CLRND 5 161.0	560001	NODAWAYCO 161.0	1	167	146.8	147	3.8%	Intact	XS542978>542979>\$1
635034	CLRND 5 161.0	560001	NODAWAYCO 161.0	1	167	146.8	147	3.8%	Intact	XS543059>543064>\$1
635034	CLRND 5 161.0	560001	NODAWAYCO 161.0	1	167	146.8	147	3.8%	Intact	XS542965>542977>\$1
635034	CLRND 5 161.0	560001	NODAWAYCO 161.0	1	167	146.8	147	3.8%	Intact	XS533338>560141>\$1
635034	CLRND 5 161.0	560001	NODAWAYCO 161.0	1	167	146.8	147	3.8%	Intact	XS532981>514804>\$1
635034	CLRND 5 161.0	560001	NODAWAYCO 161.0	1	167	146.8	147	3.8%	Intact	XS541218>541233>\$1
635034	CLRND 5 161.0	560001	NODAWAYCO 161.0	1	167	146.8	147	3.8%	Intact	XS631001>631004>\$1
635034	CLRND 5 161.0	560001	NODAWAYCO 161.0	1	167	146.8	147	3.8%	Intact	XS543031>543039>\$1
635034	CLRND 5 161.0	560001	NODAWAYCO 161.0	1	167	146.8	147	3.8%	Intact	XS631048>629068>\$1
635034	CLRND 5 161.0	560001	NODAWAYCO 161.0	1	167	146.8	147	3.8%	Intact	XS631083>631086>\$1
635034	CLRND 5 161.0	560001	NODAWAYCO 161.0	1	167	146.8	147	3.8%	Intact	XS541209>541241>\$1
635034	CLRND 5 161.0	560001	NODAWAYCO 161.0	1	167	146.8	147	3.8%	Intact	XS640105>640415>\$1
635034	CLRND 5 161.0	560001	NODAWAYCO 161.0	1	167	146.8	147	3.8%	Intact	XS641090>641096>\$1
635034	CLRND 5 161.0	560001	NODAWAYCO 161.0	1	167	146.8	147	3.8%	Intact	XS640353>640355>\$1
635034	CLRND 5 161.0	560001	NODAWAYCO 161.0	1	167	146.8	147	3.8%	Intact	XS640159>640160>\$1
635034	CLRND 5 161.0	560001	NODAWAYCO 161.0	1	167	146.8	147	3.8%	Intact	XS640109>640110>\$1
635034	CLRND 5 161.0	560001	NODAWAYCO 161.0	1	167	146.8	147	3.8%	Intact	XS640196>640198>\$1
635034	CLRND 5 161.0	560001	NODAWAYCO 161.0	1	167	146.8	147	3.8%	Intact	XS640355>640356>\$1
635034	CLRND 5 161.0	560001	NODAWAYCO 161.0	1	167	146.8	147	3.8%	Intact	XS659132>640303>\$1
635034	CLRND 5 161.0	560001	NODAWAYCO 161.0	1	167	146.8	147	3.8%	Intact	XS650228>650328>650528\$1
635034	CLRND 5 161.0	560001	NODAWAYCO 161.0	1	167	146.8	147	3.8%	Intact	XS650273>650373>650573\$1
635034	CLRND 5 161.0	560001	NODAWAYCO 161.0	1	167	146.8	147	3.8%	Intact	XS645024>645124>\$1
635034	CLRND 5 161.0	560001	NODAWAYCO 161.0	1	167	146.8	147	3.8%	Intact	LES0011
635034	CLRND 5 161.0	560001	NODAWAYCO 161.0	1	167	146.8	147	3.8%	Intact	BKR-MOR-3306
635034	CLRND 5 161.0	560001	NODAWAYCO 161.0	1	167	146.8	147	3.8%	Intact	CB961-BUS&NH

635034	CLRND 5 161.0	560001	NODAWAYCO 161.0	1	167	146.8	147	3.8%	Intact	LES0017
635034	CLRND 5 161.0	560001	NODAWAYCO 161.0	1	167	146.8	147	3.8%	Intact	XS300718>338120>\$1
635034	CLRND 5 161.0	560001	NODAWAYCO 161.0	1	167	146.8	147	3.8%	Intact	MC1299SOUTH
635034	CLRND 5 161.0	560001	NODAWAYCO 161.0	1	167	146.8	147	3.8%	Intact	CBFREM-D
635034	CLRND 5 161.0	560001	NODAWAYCO 161.0	1	167	146.8	147	3.8%	Intact	LES6702
635034	CLRND 5 161.0	560001	NODAWAYCO 161.0	1	167	146.8	147	3.8%	Intact	LES7006
635034	CLRND 5 161.0	560001	NODAWAYCO 161.0	1	167	146.7	147	3.8%	Intact	CB1250-09&97
635034	CLRND 5 161.0	560001	NODAWAYCO 161.0	1	167	146.8	147	3.8%	Intact	XS541221>300307>\$1
635034	CLRND 5 161.0	560001	NODAWAYCO 161.0	1	167	146.7	146.9	3.8%	Intact	XS635200>652564>\$1
635034	CLRND 5 161.0	560001	NODAWAYCO 161.0	1	167	146.7	146.9	3.8%	Intact	XS640078>640079>\$1
635034	CLRND 5 161.0	560001	NODAWAYCO 161.0	1	167	146.7	146.9	3.8%	Intact	XS640377>640378>643151\$1
635034	CLRND 5 161.0	560001	NODAWAYCO 161.0	1	167	146.7	146.9	3.8%	Intact	XS631107>635710>\$1
635034	CLRND 5 161.0	560001	NODAWAYCO 161.0	1	167	146.7	146.9	3.8%	Intact	XS640169>640170>\$1
635034	CLRND 5 161.0	560001	NODAWAYCO 161.0	1	167	146.7	146.9	3.8%	Intact	XS647108>647110>\$1
635034	CLRND 5 161.0	560001	NODAWAYCO 161.0	1	167	146.7	146.9	3.8%	Intact	XS652609>659198>\$1
635034	CLRND 5 161.0	560001	NODAWAYCO 161.0	1	167	146.7	146.9	3.8%	Intact	XS645011>645112>\$1
635034	CLRND 5 161.0	560001	NODAWAYCO 161.0	1	167	146.7	146.9	3.8%	Intact	XS645011>645111>\$1
635034	CLRND 5 161.0	560001	NODAWAYCO 161.0	1	167	146.7	146.9	3.8%	Intact	CB1299-BUS
635034	CLRND 5 161.0	560001	NODAWAYCO 161.0	1	167	146.7	146.9	3.8%	Intact	CB1250-11&97
635034	CLRND 5 161.0	560001	NODAWAYCO 161.0	1	167	146.7	146.9	3.8%	Intact	S991TAP
635034	CLRND 5 161.0	560001	NODAWAYCO 161.0	1	167	146.7	146.9	3.8%	Intact	CBFREM-E
635034	CLRND 5 161.0	560001	NODAWAYCO 161.0	1	167	146.7	146.9	3.8%	Intact	906N15-25-94
635034	CLRND 5 161.0	560001	NODAWAYCO 161.0	1	167	146.7	146.9	3.8%	Intact	CB994-BUS06N
635034	CLRND 5 161.0	560001	NODAWAYCO 161.0	1	167	146.7	146.9	3.8%	Intact	CB1206-16&T1
635034	CLRND 5 161.0	560001	NODAWAYCO 161.0	1	167	146.7	146.9	3.8%	Intact	XS300040>300054>\$1

635034	CLRND 5 161.0	560001	NODAWAYCO 161.0	1	167	146.7	146.9	3.8%	Intact	1211-50-LS
635034	CLRND 5 161.0	560001	NODAWAYCO 161.0	1	167	146.7	146.9	3.8%	Intact	XS543062>543064>\$1
635034	CLRND 5 161.0	560001	NODAWAYCO 161.0	1	167	146.7	146.9	3.8%	Intact	XS542965>542966>543649\$11
635034	CLRND 5 161.0	560001	NODAWAYCO 161.0	1	167	146.7	146.9	3.8%	Intact	XS640278>640279>\$1
635034	CLRND 5 161.0	560001	NODAWAYCO 161.0	1	167	146.7	146.9	3.8%	Intact	XS640256>640258>\$1
635034	CLRND 5 161.0	560001	NODAWAYCO 161.0	1	167	146.7	146.9	3.8%	Intact	XS636636>636672>\$1
635034	CLRND 5 161.0	560001	NODAWAYCO 161.0	1	167	146.7	146.9	3.8%	Intact	XS640157>640158>\$1
635034	CLRND 5 161.0	560001	NODAWAYCO 161.0	1	167	146.7	146.9	3.8%	Intact	XS640287>640288>\$1
635034	CLRND 5 161.0	560001	NODAWAYCO 161.0	1	167	146.7	146.9	3.8%	Intact	XS652533>652289>\$1
635034	CLRND 5 161.0	560001	NODAWAYCO 161.0	1	167	146.7	146.9	3.8%	Intact	XS650216>650316>650516\$1
635034	CLRND 5 161.0	560001	NODAWAYCO 161.0	1	167	146.7	146.9	3.8%	Intact	XS647904>647906>\$1
635034	CLRND 5 161.0	560001	NODAWAYCO 161.0	1	167	146.7	146.9	3.8%	Intact	XS650272>650372>650572\$1
635034	CLRND 5 161.0	560001	NODAWAYCO 161.0	1	167	146.7	146.9	3.8%	Intact	XS300617>344815>\$1
635034	CLRND 5 161.0	560001	NODAWAYCO 161.0	1	167	146.7	146.9	3.8%	Intact	LES0016
635034	CLRND 5 161.0	560001	NODAWAYCO 161.0	1	167	146.7	146.9	3.8%	Intact	LES7003
635034	CLRND 5 161.0	560001	NODAWAYCO 161.0	1	167	146.7	146.9	3.8%	Intact	LES3302
635034	CLRND 5 161.0	560001	NODAWAYCO 161.0	1	167	146.7	146.9	3.8%	Intact	LES3805B
635034	CLRND 5 161.0	560001	NODAWAYCO 161.0	1	167	146.7	146.9	3.8%	Intact	D-CIRCUIT#2B
635034	CLRND 5 161.0	560001	NODAWAYCO 161.0	1	167	146.7	146.9	3.8%	Intact	XS541241>345409>\$1
635034	CLRND 5 161.0	560001	NODAWAYCO 161.0	1	167	146.7	146.9	3.8%	Intact	XS631012>629102>\$1
635034	CLRND 5 161.0	560001	NODAWAYCO 161.0	1	167	146.7	146.9	3.8%	Intact	XS631085>629099>\$1
635034	CLRND 5 161.0	560001	NODAWAYCO 161.0	1	167	146.6	146.8	3.8%	Intact	XS636635>636640>\$1
635034	CLRND 5 161.0	560001	NODAWAYCO 161.0	1	167	146.6	146.8	3.8%	Intact	XS636620>636630>\$1
635034	CLRND 5 161.0	560001	NODAWAYCO 161.0	1	167	146.6	146.8	3.8%	Intact	XS640261>640262>\$1
635034	CLRND 5 161.0	560001	NODAWAYCO 161.0	1	167	146.6	146.8	3.8%	Intact	XS640248>640249>\$1

635034	CLRNDA 5 161.0	560001	NODAWAYCO 161.0	1	167	146.6	146.8	3.8%	Intact	XS640323>640324>\$1
635034	CLRNDA 5 161.0	560001	NODAWAYCO 161.0	1	167	146.6	146.8	3.8%	Intact	XS631110>631111>\$1
635034	CLRNDA 5 161.0	560001	NODAWAYCO 161.0	1	167	146.6	146.8	3.8%	Intact	XS640413>640414>\$1
635034	CLRNDA 5 161.0	560001	NODAWAYCO 161.0	1	167	146.6	146.8	3.8%	Intact	XS640411>640412>\$1
635034	CLRNDA 5 161.0	560001	NODAWAYCO 161.0	1	167	146.6	146.8	3.8%	Intact	XS650114>650185>\$1
635034	CLRNDA 5 161.0	560001	NODAWAYCO 161.0	1	167	146.6	146.8	3.8%	Intact	XS652531>652242>\$1
635034	CLRNDA 5 161.0	560001	NODAWAYCO 161.0	1	167	146.6	146.8	3.8%	Intact	XS650270>650370>650570\$1
635034	CLRNDA 5 161.0	560001	NODAWAYCO 161.0	1	167	146.6	146.8	3.8%	Intact	XS652614>659196>\$1
635034	CLRNDA 5 161.0	560001	NODAWAYCO 161.0	1	167	146.6	146.8	3.8%	Intact	XS645025>645125>\$1
635034	CLRNDA 5 161.0	560001	NODAWAYCO 161.0	1	167	146.6	146.8	3.8%	Intact	XS650229>650329>650529\$1
635034	CLRNDA 5 161.0	560001	NODAWAYCO 161.0	1	167	146.6	146.8	3.8%	Intact	LES0007
635034	CLRNDA 5 161.0	560001	NODAWAYCO 161.0	1	167	146.7	146.8	3.8%	Intact	XS300076>300107>\$1
635034	CLRNDA 5 161.0	560001	NODAWAYCO 161.0	1	167	146.6	146.8	3.8%	Intact	LES0012A
635034	CLRNDA 5 161.0	560001	NODAWAYCO 161.0	1	167	146.6	146.8	3.8%	Intact	MC1211-20-LS
635034	CLRNDA 5 161.0	560001	NODAWAYCO 161.0	1	167	146.6	146.8	3.8%	Intact	906S15-25-94
635034	CLRNDA 5 161.0	560001	NODAWAYCO 161.0	1	167	146.6	146.8	3.8%	Intact	CB994-BUS06S
635034	CLRNDA 5 161.0	560001	NODAWAYCO 161.0	1	167	146.6	146.8	3.8%	Intact	XS532913>533217>532942\$1
635034	CLRNDA 5 161.0	560001	NODAWAYCO 161.0	1	167	146.6	146.8	3.8%	Intact	XS631007>631030>\$1
635034	CLRNDA 5 161.0	560001	NODAWAYCO 161.0	1	167	146.6	146.8	3.8%	Intact	XS631081>631107>\$1
635034	CLRNDA 5 161.0	560001	NODAWAYCO 161.0	1	167	146.5	146.7	3.8%	Intact	XS652503>652224>\$1
635034	CLRNDA 5 161.0	560001	NODAWAYCO 161.0	1	167	146.5	146.7	3.8%	Intact	XS631082>629133>\$1
635034	CLRNDA 5 161.0	560001	NODAWAYCO 161.0	1	167	146.5	146.7	3.8%	Intact	XS636000>636001>636002\$1
635034	CLRNDA 5 161.0	560001	NODAWAYCO 161.0	1	167	146.5	146.7	3.8%	Intact	XS300039>300076>\$3
635034	CLRNDA 5 161.0	560001	NODAWAYCO 161.0	1	167	146.5	146.7	3.8%	Intact	CB1220-BUS
635034	CLRNDA 5 161.0	560001	NODAWAYCO 161.0	1	167	146.5	146.7	3.8%	Intact	XS532774>542965>\$1

635034	CLRNDA 5 161.0	560001	NODAWAYCO 161.0	1	167	146.4	146.6	3.8%	Intact	XS652551>652298>\$1
635034	CLRNDA 5 161.0	560001	NODAWAYCO 161.0	1	167	146.4	146.6	3.8%	Intact	XS300103>300006>\$1
635034	CLRNDA 5 161.0	560001	NODAWAYCO 161.0	1	167	146.4	146.6	3.8%	Intact	CB900-BUS
635034	CLRNDA 5 161.0	560001	NODAWAYCO 161.0	1	167	146.4	146.6	3.8%	Intact	XS631002>629108>\$1
635034	CLRNDA 5 161.0	560001	NODAWAYCO 161.0	1	167	146.4	146.6	3.8%	Intact	XS533248>532661>\$1
635034	CLRNDA 5 161.0	560001	NODAWAYCO 161.0	1	167	146.3	146.5	3.8%	Intact	XS635640>635650>\$1
635034	CLRNDA 5 161.0	560001	NODAWAYCO 161.0	1	167	146.3	146.5	3.8%	Intact	XS300069>300024>\$20
635034	CLRNDA 5 161.0	560001	NODAWAYCO 161.0	1	167	146.3	146.5	3.8%	Intact	XS300069>300033>\$12
635034	CLRNDA 5 161.0	560001	NODAWAYCO 161.0	1	167	146.3	146.5	3.8%	Intact	CB1209-26&31
635034	CLRNDA 5 161.0	560001	NODAWAYCO 161.0	1	167	146.3	146.5	3.8%	Intact	CB923-BUSPXM
635034	CLRNDA 5 161.0	560001	NODAWAYCO 161.0	1	167	146.3	146.5	3.8%	Intact	CB1287-BUS
635034	CLRNDA 5 161.0	560001	NODAWAYCO 161.0	1	167	146.3	146.5	3.8%	Intact	CB900BUS&979
635034	CLRNDA 5 161.0	560001	NODAWAYCO 161.0	1	167	146.3	146.5	3.8%	Intact	CB1253-BUS
635034	CLRNDA 5 161.0	560001	NODAWAYCO 161.0	1	167	146.3	146.5	3.8%	Intact	S938LINBUS
635034	CLRNDA 5 161.0	560001	NODAWAYCO 161.0	1	167	146.3	146.5	3.8%	Intact	1252TARP
635034	CLRNDA 5 161.0	560001	NODAWAYCO 161.0	1	167	146.2	146.4	3.8%	Intact	CB995-BUS938
635034	CLRNDA 5 161.0	560001	NODAWAYCO 161.0	1	167	146.1	146.3	3.8%	Intact	CB1229-BUS
635034	CLRNDA 5 161.0	560001	NODAWAYCO 161.0	1	167	145.9	146.1	3.8%	Intact	XS635034>635035>\$2
635034	CLRNDA 5 161.0	560001	NODAWAYCO 161.0	1	167	145.9	146.1	3.8%	Intact	XS635034>635035>\$1
635034	CLRNDA 5 161.0	560001	NODAWAYCO 161.0	1	167	145.8	146	3.8%	Intact	XS645455>645456>\$1
635034	CLRNDA 5 161.0	560001	NODAWAYCO 161.0	1	167	145.2	145.4	3.8%	Intact	XS631070>631069>\$1
635034	CLRNDA 5 161.0	560001	NODAWAYCO 161.0	1	167	144.9	145.1	3.8%	Intact	XS541199>541253>541371\$2
635034	CLRNDA 5 161.0	560001	NODAWAYCO 161.0	1	167	144.5	144.7	3.8%	Intact	XS635730>636400>\$1
635034	CLRNDA 5 161.0	560001	NODAWAYCO 161.0	1	167	144.1	144.3	3.8%	Intact	XS531451>531465>\$1
635034	CLRNDA 5 161.0	560001	NODAWAYCO 161.0	1	167	143.8	144	3.8%	Intact	XS532854>532663>\$1

635034	CLRNDA 5 161.0	560001	NODAWAYCO 161.0	1	167	143.8	144	3.8%	Intact	XS532853>532854>\$1
635034	CLRNDA 5 161.0	560001	NODAWAYCO 161.0	1	167	142.1	142.3	3.8%	Intact	XS300107>560643>\$1
635034	CLRNDA 5 161.0	560001	NODAWAYCO 161.0	1	167	142.1	142.3	3.8%	Intact	XS560643>560644>\$1
635034	CLRNDA 5 161.0	560001	NODAWAYCO 161.0	1	167	141.8	142	3.8%	Intact	XS542981>542956>\$1
635034	CLRNDA 5 161.0	560001	NODAWAYCO 161.0	1	167	141.8	142	3.8%	Intact	XS542981>542955>\$1
635034	CLRNDA 5 161.0	560001	NODAWAYCO 161.0	1	167	141.4	141.6	3.8%	Intact	XS635000>645456>\$1
635034	CLRNDA 5 161.0	560001	NODAWAYCO 161.0	1	167	141.2	141.4	3.8%	Intact	CB3456-55&CB
635034	CLRNDA 5 161.0	560001	NODAWAYCO 161.0	1	167	140	140.2	3.8%	Intact	XS300039>560620>\$1
635034	CLRNDA 5 161.0	560001	NODAWAYCO 161.0	1	167	111.5	111.7	3.8%	Intact	XS635034>635038>\$1
640234	HUMBOLT5 161.0	3WNDTR	S975 T4 WND	1	67.2	118.4	119.4	5.7%	Intact	CB1263-BUS
640234	HUMBOLT5 161.0	3WNDTR	S975 T4 WND	1	67.2	112.3	113.2	4.8%	Intact	XS646263>647111>648263\$1
640234	HUMBOLT5 161.0	3WNDTR	S975 T4 WND	1	67.2	110.4	112.8	15.2%	Intact	CB1280-BUS
640234	HUMBOLT5 161.0	3WNDTR	S975 T4 WND	1	67.2	111.3	112.6	8.6%	Intact	XS646263>646280>\$1
640234	HUMBOLT5 161.0	3WNDTR	S975 T4 WND	1	67.2	110.4	111.1	4.8%	Intact	S1263T1 AUTO
640234	HUMBOLT5 161.0	3WNDTR	S975 T4 WND	1	67.2	106.2	106.8	3.8%	Intact	XS647111>647963>\$1
646263	S1263 5 161.0	3WNDTR	S1263 T1 WND	1	106	100.7	101.2	4.8%	Intact	XS640234>647975>648275\$1
647975	S975 8 69.00	3WNDTR	S975 T4 WND	1	67.2	115.9	116.8	5.7%	Intact	CB1263-BUS
647975	S975 8 69.00	3WNDTR	S975 T4 WND	1	67.2	109.4	111.7	15.2%	Intact	CB1280-BUS
647975	S975 8 69.00	3WNDTR	S975 T4 WND	1	67.2	110	111.3	8.6%	Intact	XS646263>646280>\$1
647975	S975 8 69.00	3WNDTR	S975 T4 WND	1	67.2	110	110.8	5.7%	Intact	XS646263>647111>648263\$1
647975	S975 8 69.00	3WNDTR	S975 T4 WND	1	67.2	108	108.7	3.8%	Intact	S1263T1 AUTO
647975	S975 8 69.00	3WNDTR	S975 T4 WND	1	67.2	104	104.6	3.8%	Intact	XS647111>647963>\$1

**Table C-4: 2017 Summer Contingency Analysis Thermal Violations
NERC Category B and C Single-Event Contingencies
Loading Limit 100%, DF > 3%, Screened
GEN-2010-041 10.5 MW Wind Project**

FromBusNum	FromBusName	ToBusNum	ToBusName	Circuit	Rating	Benchmark (%)	Change (%)	DF	Prior	Contingency
635034	CLRND 5 161.0	560001	NODAWAYCO 161.0	1	153	160.7	160.9	3.8%	Intact	CB3458-40&CO
635034	CLRND 5 161.0	560001	NODAWAYCO 161.0	1	153	155.1	156.7	21.9%	Intact	S1217 AUTOV2
635034	CLRND 5 161.0	560001	NODAWAYCO 161.0	1	153	155.5	156.2	9.5%	Intact	S1221 AUTOV2
635034	CLRND 5 161.0	560001	NODAWAYCO 161.0	1	153	155.1	156.1	13.3%	Intact	S1210 AUTOV2
635034	CLRND 5 161.0	560001	NODAWAYCO 161.0	1	153	155.2	155.7	6.7%	Intact	S1221 AUTOV3
635034	CLRND 5 161.0	560001	NODAWAYCO 161.0	1	153	154.6	155.3	10.5%	Intact	S1217 AUTOV3
635034	CLRND 5 161.0	560001	NODAWAYCO 161.0	1	153	154.7	155.3	7.6%	Intact	S1210 AUTOV3
640234	HUMBOLT5 161.0	3WNDTR	S975 T4 WND	1	67.2	111.2	112.2	6.7%	Intact	XS646263>646280>\$1
640234	HUMBOLT5 161.0	3WNDTR	S975 T4 WND	1	67.2	103.3	105.3	13.3%	Intact	CB1280-BUS
647975	S975 8 69.00	3WNDTR	S975 T4 WND	1	67.2	108.7	109.7	7.6%	Intact	XS646263>646280>\$1
647975	S975 8 69.00	3WNDTR	S975 T4 WND	1	67.2	101.4	103.4	13.3%	Intact	CB1280-BUS

**Table C-5: 2017 Winter Contingency Analysis Thermal Violations
NERC Category B and C Single-Event Contingencies
Loading Limit 100%, DF > 3%, Screened
GEN-2010-041 10.5 MW Wind Project**

FromBusNum	FromBusName	ToBusNum	ToBusName	Circuit	Rating	Benchmark (%)	Change (%)	DF	Prior	Contingency
640088	BPS SUB7 115.0	640111	CLATONA7 115.0	1	137	100.4	101	7.6%	Intact	XS640088>640278>\$1
635034	CLRND 5 161.0	560001	NODAWAYCO 161.0	1	167	160.4	160.7	3.8%	Intact	CB3458-40&CO

635034	CLRND 5 161.0	560001	NODAWAYCO 161.0	1	167	157.9	158.1	3.8%	Intact	XS640139>645458>\$1
635034	CLRND 5 161.0	560001	NODAWAYCO 161.0	1	167	157.4	157.6	3.8%	Intact	CB3455-40&T3
635034	CLRND 5 161.0	560001	NODAWAYCO 161.0	1	167	156.4	156.6	3.8%	Intact	XS635017>928113>\$1
635034	CLRND 5 161.0	560001	NODAWAYCO 161.0	1	167	155	155.2	3.8%	Intact	XS635000>635001>635025\$1
635034	CLRND 5 161.0	560001	NODAWAYCO 161.0	1	167	154.4	154.6	3.8%	Intact	CB1263-BUS
635034	CLRND 5 161.0	560001	NODAWAYCO 161.0	1	167	153.9	154.2	3.8%	Intact	BKR-HMB-1604
635034	CLRND 5 161.0	560001	NODAWAYCO 161.0	1	167	153.9	154.1	3.8%	Intact	XS640234>646399>\$1
635034	CLRND 5 161.0	560001	NODAWAYCO 161.0	1	167	153.6	153.8	3.8%	Intact	CB1366-BUS
635034	CLRND 5 161.0	560001	NODAWAYCO 161.0	1	167	153.6	153.8	3.8%	Intact	XS646244>646366>\$1
635034	CLRND 5 161.0	560001	NODAWAYCO 161.0	1	167	153.2	153.4	3.8%	Intact	CB1206-44&T1
635034	CLRND 5 161.0	560001	NODAWAYCO 161.0	1	167	152.7	152.9	3.8%	Intact	CBWAG-T1-54
635034	CLRND 5 161.0	560001	NODAWAYCO 161.0	1	167	152.4	152.6	3.8%	Intact	CB1250-11&97
635034	CLRND 5 161.0	560001	NODAWAYCO 161.0	1	167	117.1	117.2	3.8%	Intact	XS635034>635038>\$1
640234	HUMBOLT5 161.0	3WNDTR	S975 T4 WND	1	67.2	123.2	124.1	5.7%	Intact	CB1263-BUS
640234	HUMBOLT5 161.0	3WNDTR	S975 T4 WND	1	67.2	116.9	117.6	4.8%	Intact	XS646263>647111>648263\$1
640234	HUMBOLT5 161.0	3WNDTR	S975 T4 WND	1	67.2	115.5	116.8	8.6%	Intact	XS646263>646280>\$1
640234	HUMBOLT5 161.0	3WNDTR	S975 T4 WND	1	67.2	114	116.3	15.2%	Intact	CB1280-BUS
640234	HUMBOLT5 161.0	3WNDTR	S975 T4 WND	1	67.2	114.7	115.3	3.8%	Intact	S1263T1 AUTO
646263	S1263 5 161.0	3WNDTR	S1263 T1 WND	1	106	105.1	105.6	4.8%	Intact	XS640234>647975>648275\$1
646263	S1263 5 161.0	3WNDTR	S1263 T1 WND	1	106	102.8	103.2	4.8%	Intact	CB975-T4-965
647975	S975 8 69.00	3WNDTR	S975 T4 WND	1	67.2	120.3	121.2	4.8%	Intact	CB1263-BUS
647975	S975 8 69.00	3WNDTR	S975 T4 WND	1	67.2	114	115.3	8.6%	Intact	XS646263>646280>\$1
647975	S975 8 69.00	3WNDTR	S975 T4 WND	1	67.2	112.9	115.2	14.3%	Intact	CB1280-BUS
647975	S975 8 69.00	3WNDTR	S975 T4 WND	1	67.2	114.3	115	4.8%	Intact	XS646263>647111>648263\$1
647975	S975 8 69.00	3WNDTR	S975 T4 WND	1	67.2	107.8	108.3	3.8%	Intact	XS647111>647963>\$1

647111	W BROCK8 69.00	3WNDTR	S1263 T1 WND	1	106	103.6	104.1	4.8%	Intact	XS640234>647975>648275\$1
647111	W BROCK8 69.00	3WNDTR	S1263 T1 WND	1	106	101.4	101.8	4.8%	Intact	CB975-T4-965

**Table C-6: 2012 Spring Contingency Analysis Thermal Violations
NERC Category C Double-Event Contingencies
Loading Limit 100%, DF > 3%, Screened
GEN-2010-041 10.5 MW Wind Project**

FromBusNum	FromBusName	ToBusNum	ToBusName	Circuit	Rating	Benchmark (%)	Change (%)	DF	Prior	Contingency
647101	AUBRNT 8 69.00	647975	S975 8 69.00	1	72	123.8	130	34.3%	Kelly to GEN2007-015	CB1280-BUS
647101	AUBRNT 8 69.00	647975	S975 8 69.00	1	72	113.7	120.4	40.0%	Kelly to GEN2007-015	XS640234>646280>\$1
647101	AUBRNT 8 69.00	647975	S975 8 69.00	1	72	113.7	120.1	37.1%	S1280 to Humboldt	XS532913>560610>\$1
640076	BEATRCE7 115.0	640361	STEINER7 115.0	1	120	156.2	166.9	86.7%	Kelly to GEN2007-015	CBHUM-80&T4
640088	BPS SUB7 115.0	640111	CLATONA7 115.0	1	137	107.7	109.2	20.0%	S1280 to Humboldt	XS640088>640278>\$1
640088	BPS SUB7 115.0	640111	CLATONA7 115.0	1	137	104	104.7	8.6%	S975 (Humboldt) T4 161-69	XS640088>640278>\$1
640088	BPS SUB7 115.0	640111	CLATONA7 115.0	1	137	103.9	104.4	7.6%	Kelly to GEN2007-015	XS640088>640278>\$1
640088	BPS SUB7 115.0	640111	CLATONA7 115.0	1	137	101.9	102.4	6.7%	S1399 to Humboldt	XS640088>640278>\$1
533152	CIRCLVL3 115.0	533331	KING HL3 115.0	1	92	119.6	127.3	60.0%	S1399 to Humboldt	XS532913>532920>\$1
640111	CLATONA7 115.0	640278	SHELDON7 115.0	1	137	103.3	104.8	19.0%	S1280 to Humboldt	XS640088>640278>\$1
635034	CLRND 5 161.0	560001	NODAWAYCO 161.0	1	153	161	161.2	3.8%	S1399 to Humboldt	XS640139>560620>\$1
635034	CLRND 5 161.0	560001	NODAWAYCO 161.0	1	153	159.9	160.2	4.8%	S1399 to Humboldt	CB3458-40&CO
635034	CLRND 5 161.0	560001	NODAWAYCO 161.0	1	153	159	159.3	3.8%	S1280 to Humboldt	CB3458-40&CO
635034	CLRND 5 161.0	560001	NODAWAYCO 161.0	1	153	158.4	158.8	4.8%	S1399 to Humboldt	XS640139>645458>\$1
635034	CLRND 5 161.0	560001	NODAWAYCO 161.0	1	153	157.7	158	3.8%	S975 (Humboldt) T4 161-69	XS640139>645458>\$1
635034	CLRND 5 161.0	560001	NODAWAYCO 161.0	1	153	156.1	156.3	3.8%	S1399 to Humboldt	XS300039>300076>\$3
635034	CLRND 5 161.0	560001	NODAWAYCO 161.0	1	153	155.7	155.9	3.8%	S1399 to Humboldt	XS541251>541359>\$1

635034	CLRND 5	161.0	560001	NODAWAYCO	161.0	1	153	155.5	155.7	3.8%	S1399 to Humboldt	XS652519>652556>\$1
635034	CLRND 5	161.0	560001	NODAWAYCO	161.0	1	153	155.4	155.6	3.8%	S1399 to Humboldt	CB1263-BUS
635034	CLRND 5	161.0	560001	NODAWAYCO	161.0	1	153	155	155.2	3.8%	S1399 to Humboldt	XS636400>636645>\$1
635034	CLRND 5	161.0	560001	NODAWAYCO	161.0	1	153	155	155.2	3.8%	S1399 to Humboldt	XS652540>652542>\$1
635034	CLRND 5	161.0	560001	NODAWAYCO	161.0	1	153	154.9	155.1	3.8%	S1399 to Humboldt	XS533332>560141>\$1
635034	CLRND 5	161.0	560001	NODAWAYCO	161.0	1	153	154.5	154.7	3.8%	S1399 to Humboldt	XS532771>532773>\$1
635034	CLRND 5	161.0	560001	NODAWAYCO	161.0	1	153	154.5	154.7	3.8%	S1399 to Humboldt	TWR-SCH-NH
635034	CLRND 5	161.0	560001	NODAWAYCO	161.0	1	153	154.4	154.6	3.8%	S1399 to Humboldt	XS533217>533337>\$1
635034	CLRND 5	161.0	560001	NODAWAYCO	161.0	1	153	154.3	154.5	3.8%	S1399 to Humboldt	XS300101>505498>\$1
635034	CLRND 5	161.0	560001	NODAWAYCO	161.0	1	153	154.3	154.5	3.8%	S1399 to Humboldt	XS635650>635651>\$1
635034	CLRND 5	161.0	560001	NODAWAYCO	161.0	1	153	154.2	154.4	3.8%	S1399 to Humboldt	XS542969>543057>\$1
635034	CLRND 5	161.0	560001	NODAWAYCO	161.0	1	153	154.2	154.4	3.8%	S1399 to Humboldt	CB963-BUSAUB
635034	CLRND 5	161.0	560001	NODAWAYCO	161.0	1	153	154.2	154.4	3.8%	S1399 to Humboldt	XS532984>533063>\$1
635034	CLRND 5	161.0	560001	NODAWAYCO	161.0	1	153	154.2	154.4	3.8%	S1399 to Humboldt	XS533001>533674>533086\$1
635034	CLRND 5	161.0	560001	NODAWAYCO	161.0	1	153	154.2	154.4	3.8%	S1399 to Humboldt	XS543057>543058>\$1
635034	CLRND 5	161.0	560001	NODAWAYCO	161.0	1	153	154.2	154.4	3.8%	S1399 to Humboldt	XS543064>543072>\$1
635034	CLRND 5	161.0	560001	NODAWAYCO	161.0	1	153	154.2	154.4	3.8%	S1399 to Humboldt	XS631112>630033>\$1
635034	CLRND 5	161.0	560001	NODAWAYCO	161.0	1	153	154.2	154.4	3.8%	S1399 to Humboldt	XS640171>640278>\$1
635034	CLRND 5	161.0	560001	NODAWAYCO	161.0	1	153	154.2	154.4	3.8%	S1399 to Humboldt	CB974-BUS
635034	CLRND 5	161.0	560001	NODAWAYCO	161.0	1	153	154.2	154.4	3.8%	S1399 to Humboldt	LN-1175B
635034	CLRND 5	161.0	560001	NODAWAYCO	161.0	1	153	154.2	154.4	3.8%	S1399 to Humboldt	CB974-BUS-EN
635034	CLRND 5	161.0	560001	NODAWAYCO	161.0	1	153	154.1	154.3	3.8%	S1399 to Humboldt	XS532771>533416>532807\$1
635034	CLRND 5	161.0	560001	NODAWAYCO	161.0	1	153	154.1	154.3	3.8%	S1399 to Humboldt	XS560332>640076>\$1
635034	CLRND 5	161.0	560001	NODAWAYCO	161.0	1	153	154.1	154.3	3.8%	S1399 to Humboldt	XS533413>533419>\$1
635034	CLRND 5	161.0	560001	NODAWAYCO	161.0	1	153	154.1	154.3	3.8%	S1399 to Humboldt	XS533332>640426>\$1
635034	CLRND 5	161.0	560001	NODAWAYCO	161.0	1	153	154.1	154.3	3.8%	S1399 to Humboldt	XS631004>631081>\$1
635034	CLRND 5	161.0	560001	NODAWAYCO	161.0	1	153	154.1	154.3	3.8%	S1399 to Humboldt	XS640105>640178>\$1

635034	CLRND 5	161.0	560001	NODAWAYCO	161.0	1	153	154.1	154.3	3.8%	S1399 to Humboldt	S1217 AUTOV2
635034	CLRND 5	161.0	560001	NODAWAYCO	161.0	1	153	154	154.2	3.8%	S1399 to Humboldt	XS300719>505472>\$1
635034	CLRND 5	161.0	560001	NODAWAYCO	161.0	1	153	154	154.2	3.8%	S1399 to Humboldt	XS533151>533166>\$1
635034	CLRND 5	161.0	560001	NODAWAYCO	161.0	1	153	154	154.2	3.8%	S1399 to Humboldt	XS532791>532794>\$1
635034	CLRND 5	161.0	560001	NODAWAYCO	161.0	1	153	154	154.2	3.8%	S1399 to Humboldt	XS300597>300602>\$1
635034	CLRND 5	161.0	560001	NODAWAYCO	161.0	1	153	154	154.2	3.8%	S1399 to Humboldt	XS300596>300602>\$1
635034	CLRND 5	161.0	560001	NODAWAYCO	161.0	1	153	154	154.2	3.8%	S1399 to Humboldt	XS300136>514906>\$1
635034	CLRND 5	161.0	560001	NODAWAYCO	161.0	1	153	154	154.2	3.8%	S1399 to Humboldt	XS300120>300172>\$2
635034	CLRND 5	161.0	560001	NODAWAYCO	161.0	1	153	154	154.2	3.8%	S1399 to Humboldt	XS300120>300172>\$1
635034	CLRND 5	161.0	560001	NODAWAYCO	161.0	1	153	154	154.2	3.8%	S1399 to Humboldt	XS532873>533381>532897\$1
635034	CLRND 5	161.0	560001	NODAWAYCO	161.0	1	153	154	154.2	3.8%	S1399 to Humboldt	XS533151>533194>\$1
635034	CLRND 5	161.0	560001	NODAWAYCO	161.0	1	153	154	154.2	3.8%	S1399 to Humboldt	XS533001>533005>\$1
635034	CLRND 5	161.0	560001	NODAWAYCO	161.0	1	153	154	154.2	3.8%	S1399 to Humboldt	XS300111>300636>\$1
635034	CLRND 5	161.0	560001	NODAWAYCO	161.0	1	153	154	154.2	3.8%	S1399 to Humboldt	XS631013>631017>\$1
635034	CLRND 5	161.0	560001	NODAWAYCO	161.0	1	153	154	154.2	3.8%	S1399 to Humboldt	XS541210>541382>\$1
635034	CLRND 5	161.0	560001	NODAWAYCO	161.0	1	153	154	154.2	3.8%	S1399 to Humboldt	XS541209>541271>\$1
635034	CLRND 5	161.0	560001	NODAWAYCO	161.0	1	153	154	154.2	3.8%	S1399 to Humboldt	XS541209>541234>\$1
635034	CLRND 5	161.0	560001	NODAWAYCO	161.0	1	153	154	154.2	3.8%	S1399 to Humboldt	XS533322>533337>\$1
635034	CLRND 5	161.0	560001	NODAWAYCO	161.0	1	153	154	154.2	3.8%	S1399 to Humboldt	XS636605>270867>\$1
635034	CLRND 5	161.0	560001	NODAWAYCO	161.0	1	153	154	154.2	3.8%	S1399 to Humboldt	XS636001>656353>\$1
635034	CLRND 5	161.0	560001	NODAWAYCO	161.0	1	153	154	154.2	3.8%	S1399 to Humboldt	XS636673>633261>\$1
635034	CLRND 5	161.0	560001	NODAWAYCO	161.0	1	153	154	154.2	3.8%	S1399 to Humboldt	XS635651>635670>\$2
635034	CLRND 5	161.0	560001	NODAWAYCO	161.0	1	153	154	154.2	3.8%	S1399 to Humboldt	XS636675>636676>\$1
635034	CLRND 5	161.0	560001	NODAWAYCO	161.0	1	153	154	154.2	3.8%	S1399 to Humboldt	XS640093>640330>\$1
635034	CLRND 5	161.0	560001	NODAWAYCO	161.0	1	153	154	154.2	3.8%	S1399 to Humboldt	XS640117>640394>\$1
635034	CLRND 5	161.0	560001	NODAWAYCO	161.0	1	153	154	154.2	3.8%	S1399 to Humboldt	XS640235>640361>\$1
635034	CLRND 5	161.0	560001	NODAWAYCO	161.0	1	153	154	154.2	3.8%	S1399 to Humboldt	XS640208>640426>\$1

635034	CLRND 5	161.0	560001	NODAWAYCO	161.0	1	153	154	154.2	3.8%	S1399 to Humboldt	XS640271>640272>640274\$1
635034	CLRND 5	161.0	560001	NODAWAYCO	161.0	1	153	154	154.2	3.8%	S1399 to Humboldt	XS640093>640102>\$1
635034	CLRND 5	161.0	560001	NODAWAYCO	161.0	1	153	154	154.2	3.8%	S1399 to Humboldt	XS640102>640103>643029\$1
635034	CLRND 5	161.0	560001	NODAWAYCO	161.0	1	153	154	154.2	3.8%	S1399 to Humboldt	XS640312>640313>640315\$1
635034	CLRND 5	161.0	560001	NODAWAYCO	161.0	1	153	154	154.2	3.8%	S1399 to Humboldt	XS640272>640273>\$1
635034	CLRND 5	161.0	560001	NODAWAYCO	161.0	1	153	154	154.2	3.8%	S1399 to Humboldt	XS640058>640367>\$1
635034	CLRND 5	161.0	560001	NODAWAYCO	161.0	1	153	154	154.2	3.8%	S1399 to Humboldt	XS640284>640347>\$1
635034	CLRND 5	161.0	560001	NODAWAYCO	161.0	1	153	154	154.2	3.8%	S1399 to Humboldt	XS640361>647966>\$1
635034	CLRND 5	161.0	560001	NODAWAYCO	161.0	1	153	154	154.2	3.8%	S1399 to Humboldt	XS640105>640106>\$1
635034	CLRND 5	161.0	560001	NODAWAYCO	161.0	1	153	154	154.2	3.8%	S1399 to Humboldt	XS640082>640326>\$1
635034	CLRND 5	161.0	560001	NODAWAYCO	161.0	1	153	154	154.2	3.8%	S1399 to Humboldt	XS647006>647928>\$1
635034	CLRND 5	161.0	560001	NODAWAYCO	161.0	1	153	154	154.2	3.8%	S1399 to Humboldt	XS652522>652438>\$1
635034	CLRND 5	161.0	560001	NODAWAYCO	161.0	1	153	154	154.2	3.8%	S1399 to Humboldt	XS652517>659121>\$1
635034	CLRND 5	161.0	560001	NODAWAYCO	161.0	1	153	154	154.2	3.8%	S1399 to Humboldt	XS652521>652527>\$1
635034	CLRND 5	161.0	560001	NODAWAYCO	161.0	1	153	154	154.2	3.8%	S1399 to Humboldt	XS650262>650267>\$1
635034	CLRND 5	161.0	560001	NODAWAYCO	161.0	1	153	154	154.2	3.8%	S1399 to Humboldt	XS652550>652554>\$1
635034	CLRND 5	161.0	560001	NODAWAYCO	161.0	1	153	154	154.2	3.8%	S1399 to Humboldt	XS652523>602004>\$1
635034	CLRND 5	161.0	560001	NODAWAYCO	161.0	1	153	154	154.2	3.8%	S1399 to Humboldt	XS652626>660007>\$1
635034	CLRND 5	161.0	560001	NODAWAYCO	161.0	1	153	154	154.2	3.8%	S1399 to Humboldt	XS647902>647937>\$1
635034	CLRND 5	161.0	560001	NODAWAYCO	161.0	1	153	154	154.2	3.8%	S1399 to Humboldt	XS652502>652517>\$1
635034	CLRND 5	161.0	560001	NODAWAYCO	161.0	1	153	154	154.2	3.8%	S1399 to Humboldt	XS647874>647995>\$1
635034	CLRND 5	161.0	560001	NODAWAYCO	161.0	1	153	154	154.2	3.8%	S1399 to Humboldt	XS659130>659132>\$1
635034	CLRND 5	161.0	560001	NODAWAYCO	161.0	1	153	154	154.2	3.8%	S1399 to Humboldt	XS659154>659188>\$1
635034	CLRND 5	161.0	560001	NODAWAYCO	161.0	1	153	154	154.2	3.8%	S1399 to Humboldt	XS300085>300086>\$1
635034	CLRND 5	161.0	560001	NODAWAYCO	161.0	1	153	154	154.2	3.8%	S1399 to Humboldt	XS300076>300249>\$1
635034	CLRND 5	161.0	560001	NODAWAYCO	161.0	1	153	154	154.2	3.8%	S1399 to Humboldt	XS300061>300493>\$1
635034	CLRND 5	161.0	560001	NODAWAYCO	161.0	1	153	154	154.2	3.8%	S1399 to Humboldt	LN-FRIEND

635034	CLRND 5	161.0	560001	NODAWAYCO	161.0	1	153	154	154.2	3.8%	S1399 to Humboldt	MC995-38-94
635034	CLRND 5	161.0	560001	NODAWAYCO	161.0	1	153	154	154.2	3.8%	S1399 to Humboldt	XS300076>300249>\$2
635034	CLRND 5	161.0	560001	NODAWAYCO	161.0	1	153	154	154.2	3.8%	S1399 to Humboldt	CB995-BUS
635034	CLRND 5	161.0	560001	NODAWAYCO	161.0	1	153	154	154.2	3.8%	S1399 to Humboldt	D-CIRCUIT #4
635034	CLRND 5	161.0	560001	NODAWAYCO	161.0	1	153	154	154.2	3.8%	S1399 to Humboldt	CBFREM-D-C-B
635034	CLRND 5	161.0	560001	NODAWAYCO	161.0	1	153	154	154.2	3.8%	S1399 to Humboldt	XS300080>301015>\$1
635034	CLRND 5	161.0	560001	NODAWAYCO	161.0	1	153	154	154.2	3.8%	S1399 to Humboldt	LES7002
635034	CLRND 5	161.0	560001	NODAWAYCO	161.0	1	153	154	154.2	3.8%	S1399 to Humboldt	XS300085>300777>\$1
635034	CLRND 5	161.0	560001	NODAWAYCO	161.0	1	153	154	154.2	3.8%	S1399 to Humboldt	LES6203
635034	CLRND 5	161.0	560001	NODAWAYCO	161.0	1	153	153.9	154.1	3.8%	S1399 to Humboldt	XS532794>532800>\$1
635034	CLRND 5	161.0	560001	NODAWAYCO	161.0	1	153	153.9	154.1	3.8%	S1399 to Humboldt	XS532861>533326>532888\$1
635034	CLRND 5	161.0	560001	NODAWAYCO	161.0	1	153	153.9	154.1	3.8%	S1399 to Humboldt	LES0011
635034	CLRND 5	161.0	560001	NODAWAYCO	161.0	1	153	153.8	154	3.8%	S1399 to Humboldt	D-CIRCUIT#15
635034	CLRND 5	161.0	560001	NODAWAYCO	161.0	1	153	153.7	153.9	3.8%	S1399 to Humboldt	BKR-MOR-3306
635034	CLRND 5	161.0	560001	NODAWAYCO	161.0	1	153	153.7	153.9	3.8%	S1399 to Humboldt	BKR-WAG-3004
635034	CLRND 5	161.0	560001	NODAWAYCO	161.0	1	153	152.5	152.7	3.8%	S1399 to Humboldt	XS532765>532766>\$1
635034	CLRND 5	161.0	560001	NODAWAYCO	161.0	1	153	147.1	147.3	3.8%	S1399 to Humboldt	XS532766>532652>\$1
635034	CLRND 5	161.0	560001	NODAWAYCO	161.0	1	153	147.1	147.3	3.8%	S1399 to Humboldt	XS532766>532653>\$1
635034	CLRND 5	161.0	560001	NODAWAYCO	161.0	1	153	146.4	146.6	3.8%	S1399 to Humboldt	XS531451>640325>\$1
635034	CLRND 5	161.0	560001	NODAWAYCO	161.0	1	153	145.8	146.1	4.8%	S1399 to Humboldt	XS541199>640139>\$1
635034	CLRND 5	161.0	560001	NODAWAYCO	161.0	1	153	145.5	145.8	3.8%	S1399 to Humboldt	XS300039>560620>\$1
635034	CLRND 5	161.0	560001	NODAWAYCO	161.0	1	153	143.3	143.5	3.8%	S1399 to Humboldt	XS532797>532751>\$1
635034	CLRND 5	161.0	560001	NODAWAYCO	161.0	1	153	137.8	138	3.8%	S1399 to Humboldt	XS560001>560617>\$1
635034	CLRND 5	161.0	560001	NODAWAYCO	161.0	1	153	137.8	138	3.8%	S1399 to Humboldt	XS560617>560618>\$1
560332	G10-47T	115.0	640208	HARBINE7	115.0	1	99	121.3	122.1	6.7%	Kelly to GEN2007-015	CBHUM-80&T4
560332	G10-47T	115.0	640208	HARBINE7	115.0	1	99	118.4	118.8	3.8%	Kelly to GEN2007-015	XS640088>640278>\$1
560332	G10-47T	115.0	640208	HARBINE7	115.0	1	99	109.9	110.2	3.8%	Kelly to GEN2007-015	XS640088>640111>\$1

560332	G10-47T 115.0	640208	HARBINE7 115.0	1	99	108.7	109.1	3.8%	Kelly to GEN2007-015	XS640111>640278>\$1
560332	G10-47T 115.0	640208	HARBINE7 115.0	1	99	107.7	108.7	10.5%	S1280 to Humboldt	XS532913>560610>\$1
560332	G10-47T 115.0	640208	HARBINE7 115.0	1	99	107.7	108.6	8.6%	Kelly to GEN2007-015	XS640234>646280>\$1
560332	G10-47T 115.0	640208	HARBINE7 115.0	1	99	105.6	106.7	9.5%	Kelly to GEN2007-015	CB1280-BUS
560332	G10-47T 115.0	640208	HARBINE7 115.0	1	99	100.4	100.8	3.8%	Kelly to GEN2007-015	BKR-MOR-3304
640234	HUMBOLTS 161.0	3WNDTR	HUMBOLDT T2 WND	1	126	151.4	159.3	94.3%	Kelly to GEN2007-015	CBHUM-80&T4
640234	HUMBOLTS 161.0	3WNDTR	S975 T4 WND	1	67.2	154.4	160	35.2%	Kelly to GEN2007-015	CB1280-BUS
640234	HUMBOLTS 161.0	3WNDTR	S975 T4 WND	1	67.2	144.3	150.5	39.0%	Kelly to GEN2007-015	XS640234>646280>\$1
640234	HUMBOLTS 161.0	3WNDTR	S975 T4 WND	1	67.2	144.3	149.9	35.2%	S1280 to Humboldt	XS532913>560610>\$1
640234	HUMBOLTS 161.0	3WNDTR	S975 T4 WND	1	67.2	108.1	109.5	9.5%	Kelly to GEN2007-015	XS646263>646280>\$1
640234	HUMBOLTS 161.0	3WNDTR	S975 T4 WND	1	67.2	107.1	108	5.7%	Kelly to GEN2007-015	CB1263-BUS
640235	HUMBOLT7 115.0	3WNDTR	HUMBOLDT T2 WND	1	126	152.6	160.4	93.3%	Kelly to GEN2007-015	CBHUM-80&T4
640235	HUMBOLT7 115.0	3WNDTR	HUMBOLDT T2 WND	1	126	152.6	160.4	93.3%	Kelly to GEN2007-015	CBHUM-80&T4
533217	KELLY 3 115.0	3WNDTR	KELLY 1X WND	1	168	115	121.2	100.0%	S1399 to Humboldt	XS532913>532920>\$1
533217	KELLY 3 115.0	533331	KING HL3 115.0	1	92	121.8	129.5	61.0%	S1399 to Humboldt	XS532913>532920>\$1
532913	KELLY 5 161.0	3WNDTR	KELLY 1X WND	1	168	114.5	120.7	98.1%	S1399 to Humboldt	XS532913>532920>\$1
532913	KELLY 5 161.0	532920	TECHILL5 161.0	1	161	119.1	126.6	97.1%	S1399 to Humboldt	XS532913>533217>532942\$1
533332	KNOB HL3 115.0	560141	G09-40T 115.0	1	92	110.4	115.2	37.1%	S1399 to Humboldt	XS532913>532920>\$1
532990	MIDIAN 4 138.0	3WNDTR	MIDIAN3X WND	1	79	115.2	115.8	4.8%	S1399 to Humboldt	XS532768>532796>\$1
532990	MIDIAN 4 138.0	3WNDTR	MIDIAN3X WND	1	79	111	111.6	4.8%	S1399 to Humboldt	XS532766>532773>\$1
532990	MIDIAN 4 138.0	3WNDTR	MIDIAN3X WND	1	79	108	108.7	4.8%	S1399 to Humboldt	XS532797>532751>\$1
532990	MIDIAN 4 138.0	3WNDTR	MIDIAN3X WND	1	79	105.3	108	20.0%	S1399 to Humboldt	XS532920>533182>533885\$1
532990	MIDIAN 4 138.0	3WNDTR	MIDIAN3X WND	1	79	105.5	106.7	9.5%	S1399 to Humboldt	XS532913>533217>532942\$1
532990	MIDIAN 4 138.0	3WNDTR	MIDIAN3X WND	1	79	104.7	105.3	4.8%	S1399 to Humboldt	XS532794>532797>\$1
532990	MIDIAN 4 138.0	3WNDTR	MIDIAN3X WND	1	79	103.9	104.6	4.8%	S1399 to Humboldt	XS532793>542981>\$1
532990	MIDIAN 4 138.0	3WNDTR	MIDIAN3X WND	1	79	103.8	104.5	4.8%	S1399 to Humboldt	XS532772>542977>\$1

532990	MIDIAN 4	138.0	3WNDTR	MIDIAN3X	WND	1	79	103.8	104.5	4.8%	S1399 to Humboldt	XS532771>532773>\$1
532990	MIDIAN 4	138.0	3WNDTR	MIDIAN3X	WND	1	79	102.7	103.3	4.8%	S1399 to Humboldt	XS532791>532797>\$1
532936	MIDIAN 5	161.0	3WNDTR	MIDIAN3X	WND	1	79	112.9	113.5	4.8%	S1399 to Humboldt	XS532768>532796>\$1
532936	MIDIAN 5	161.0	3WNDTR	MIDIAN3X	WND	1	79	108.8	109.4	4.8%	S1399 to Humboldt	XS532766>532773>\$1
532936	MIDIAN 5	161.0	3WNDTR	MIDIAN3X	WND	1	79	106.1	106.6	3.8%	S1399 to Humboldt	XS532797>532751>\$1
532936	MIDIAN 5	161.0	3WNDTR	MIDIAN3X	WND	1	79	103.1	105.6	18.1%	S1399 to Humboldt	XS532920>533182>533885\$1
532936	MIDIAN 5	161.0	3WNDTR	MIDIAN3X	WND	1	79	103.2	104.3	8.6%	S1399 to Humboldt	XS532913>533217>532942\$1
532936	MIDIAN 5	161.0	3WNDTR	MIDIAN3X	WND	1	79	103.1	103.6	3.8%	S1399 to Humboldt	XS532794>532797>\$1
532936	MIDIAN 5	161.0	3WNDTR	MIDIAN3X	WND	1	79	102.3	102.8	3.8%	S1399 to Humboldt	XS532793>542981>\$1
532936	MIDIAN 5	161.0	3WNDTR	MIDIAN3X	WND	1	79	102.1	102.7	3.8%	S1399 to Humboldt	XS532771>532773>\$1
532936	MIDIAN 5	161.0	3WNDTR	MIDIAN3X	WND	1	79	102.1	102.6	4.8%	S1399 to Humboldt	XS532772>542977>\$1
532936	MIDIAN 5	161.0	3WNDTR	MIDIAN3X	WND	1	79	101.2	101.7	3.8%	S1399 to Humboldt	XS532791>532797>\$1
647975	S975 8	69.00	3WNDTR	S975 T4	WND	1	67.2	152.1	157.5	35.2%	Kelly to GEN2007-015	CB1280-BUS
647975	S975 8	69.00	3WNDTR	S975 T4	WND	1	67.2	143.5	149.6	40.0%	Kelly to GEN2007-015	XS640234>646280>\$1
647975	S975 8	69.00	3WNDTR	S975 T4	WND	1	67.2	143.4	149.1	36.2%	S1280 to Humboldt	XS532913>560610>\$1
647975	S975 8	69.00	3WNDTR	S975 T4	WND	1	67.2	106.8	108.2	8.6%	Kelly to GEN2007-015	XS646263>646280>\$1
647975	S975 8	69.00	3WNDTR	S975 T4	WND	1	67.2	105	105.9	4.8%	Kelly to GEN2007-015	CB1263-BUS
532920	TECHILL5	161.0	532921	WM BROS5	161.0	1	84	114.1	114.8	3.8%	S1399 to Humboldt	XS532768>532796>\$1
532920	TECHILL5	161.0	532921	WM BROS5	161.0	1	84	110.4	111.1	3.8%	S1399 to Humboldt	XS532766>532773>\$1
532920	TECHILL5	161.0	532921	WM BROS5	161.0	1	84	105.2	108.1	16.2%	S1399 to Humboldt	XS532920>533182>533885\$1
532920	TECHILL5	161.0	532921	WM BROS5	161.0	1	84	106.8	107.5	3.8%	S1399 to Humboldt	XS532797>532751>\$1
532920	TECHILL5	161.0	532921	WM BROS5	161.0	1	84	105.6	107.1	6.7%	S1399 to Humboldt	XS532913>533217>532942\$1
532920	TECHILL5	161.0	532921	WM BROS5	161.0	1	84	104.3	105	3.8%	S1399 to Humboldt	XS532794>532797>\$1
532920	TECHILL5	161.0	532921	WM BROS5	161.0	1	84	102.9	103.6	3.8%	S1399 to Humboldt	XS532793>542981>\$1
532920	TECHILL5	161.0	532921	WM BROS5	161.0	1	84	102.8	103.6	3.8%	S1399 to Humboldt	XS532771>532773>\$1
532920	TECHILL5	161.0	532921	WM BROS5	161.0	1	84	102.7	103.4	3.8%	S1399 to Humboldt	XS532772>542977>\$1
532920	TECHILL5	161.0	532921	WM BROS5	161.0	1	84	102.3	103	3.8%	S1399 to Humboldt	XS532791>532797>\$1

532921	WM BROSS 161.0	532936	MIDIAN 5 161.0	1	84	110.1	110.9	3.8%	S1399 to Humboldt	XS532766>532773>\$1
532921	WM BROSS 161.0	532936	MIDIAN 5 161.0	1	84	104.8	107.7	17.1%	S1399 to Humboldt	XS532920>533182>533885\$1
532921	WM BROSS 161.0	532936	MIDIAN 5 161.0	1	84	106.5	107.2	3.8%	S1399 to Humboldt	XS532797>532751>\$1
532921	WM BROSS 161.0	532936	MIDIAN 5 161.0	1	84	105.2	106.7	5.7%	S1399 to Humboldt	XS532913>533217>532942\$1
532921	WM BROSS 161.0	532936	MIDIAN 5 161.0	1	84	104.1	104.8	3.8%	S1399 to Humboldt	XS532794>532797>\$1
532921	WM BROSS 161.0	532936	MIDIAN 5 161.0	1	84	102.6	103.4	3.8%	S1399 to Humboldt	XS532793>542981>\$1
532921	WM BROSS 161.0	532936	MIDIAN 5 161.0	1	84	102.5	103.3	3.8%	S1399 to Humboldt	XS532771>532773>\$1
532921	WM BROSS 161.0	532936	MIDIAN 5 161.0	1	84	102.4	103.1	3.8%	S1399 to Humboldt	XS532772>542977>\$1
532921	WM BROSS 161.0	532936	MIDIAN 5 161.0	1	84	102.1	102.8	3.8%	S1399 to Humboldt	XS532791>532797>\$1

**Table C-7: 2012 Summer Contingency Analysis Thermal Violations
NERC Category C Double-Event Contingencies
Loading Limit 100%, DF > 3%, Screened
GEN-2010-041 10.5 MW Wind Project**

FromBusNum	FromBusName	ToBusNum	ToBusName	Circuit	Rating	Benchmark (%)	Change (%)	DF	Prior	Contingency
647101	AUBRNT 8 69.00	647975	S975 8 69.00	1	72	118.4	124.6	35.2%	Kelly to GEN2007-015	CB1280-BUS
647101	AUBRNT 8 69.00	647975	S975 8 69.00	1	72	107.1	113.7	39.0%	Kelly to GEN2007-015	XS640234>646280>\$1
647101	AUBRNT 8 69.00	647975	S975 8 69.00	1	72	106.5	113.1	40.0%	S1280 to Humboldt	XS532913>560610>\$1
640076	BEATRCE7 115.0	640361	STEINER7 115.0	1	120	154	164.5	86.7%	Kelly to GEN2007-015	CBHUM-80&T4
533152	CIRCLVL3 115.0	533331	KING HL3 115.0	1	92	112.8	120.4	60.0%	S1399 to Humboldt	XS532913>532920>\$1
635034	CLRNDA 5 161.0	560001	NODAWAYCO 161.0	1	153	271.3	271.6	4.8%	S1399 to Humboldt	XS541251>560001>\$1
635034	CLRNDA 5 161.0	560001	NODAWAYCO 161.0	1	153	270.4	270.6	3.8%	S1280 to Humboldt	XS541251>560001>\$1
635034	CLRNDA 5 161.0	560001	NODAWAYCO 161.0	1	153	250.8	251.1	3.8%	S1399 to Humboldt	XS541251>300097>\$1
635034	CLRNDA 5 161.0	560001	NODAWAYCO 161.0	1	153	184.6	184.9	5.7%	S1399 to Humboldt	XS300097>652560>\$1

635034	CLRND 5 161.0	560001	NODAWAYCO 161.0	1	153	184.4	184.6	3.8%	S1399 to Humboldt	XS541253>541369>\$1
635034	CLRND 5 161.0	560001	NODAWAYCO 161.0	1	153	183.4	183.7	3.8%	S1280 to Humboldt	XS300097>652560>\$1
635034	CLRND 5 161.0	560001	NODAWAYCO 161.0	1	153	167	167.3	3.8%	S1399 to Humboldt	XS300073>300076>\$1
635034	CLRND 5 161.0	560001	NODAWAYCO 161.0	1	153	166.2	166.5	3.8%	S1399 to Humboldt	XS300097>300104>\$1
635034	CLRND 5 161.0	560001	NODAWAYCO 161.0	1	153	166.2	166.4	3.8%	S1280 to Humboldt	XS300073>300076>\$1
635034	CLRND 5 161.0	560001	NODAWAYCO 161.0	1	153	166.2	166.4	3.8%	S1399 to Humboldt	XS300073>300104>\$1
635034	CLRND 5 161.0	560001	NODAWAYCO 161.0	1	153	166	166.3	4.8%	S1399 to Humboldt	XS635000>635024>\$1
635034	CLRND 5 161.0	560001	NODAWAYCO 161.0	1	153	164.7	165	3.8%	S1280 to Humboldt	XS635000>635024>\$1
635034	CLRND 5 161.0	560001	NODAWAYCO 161.0	1	153	164.3	164.6	4.8%	S1399 to Humboldt	XS635000>635023>\$1
635034	CLRND 5 161.0	560001	NODAWAYCO 161.0	1	153	163.9	164.3	4.8%	S1399 to Humboldt	CBCB-CB4-GRM
635034	CLRND 5 161.0	560001	NODAWAYCO 161.0	1	153	163	163.3	3.8%	S1280 to Humboldt	XS635000>635023>\$1
635034	CLRND 5 161.0	560001	NODAWAYCO 161.0	1	153	162.6	162.9	3.8%	S1280 to Humboldt	CBCB-CB4-GRM
635034	CLRND 5 161.0	560001	NODAWAYCO 161.0	1	153	162.4	162.8	4.8%	S1399 to Humboldt	CBCB-CB3-RLH
635034	CLRND 5 161.0	560001	NODAWAYCO 161.0	1	153	161.2	161.5	3.8%	S1280 to Humboldt	CBCB-CB3-RLH
635034	CLRND 5 161.0	560001	NODAWAYCO 161.0	1	153	161.2	161.4	3.8%	S975 (Humboldt) T4 161-69	CBCB-CB3-RLH
635034	CLRND 5 161.0	560001	NODAWAYCO 161.0	1	153	159.1	159.4	3.8%	S1399 to Humboldt	XS635017>635630>\$1
635034	CLRND 5 161.0	560001	NODAWAYCO 161.0	1	153	158.8	159.1	4.8%	S1399 to Humboldt	RAUN-NEAL3T2
635034	CLRND 5 161.0	560001	NODAWAYCO 161.0	1	153	158.8	159.1	3.8%	S1399 to Humboldt	XS635200>635213>\$1
635034	CLRND 5 161.0	560001	NODAWAYCO 161.0	1	153	158.7	159	4.8%	S1399 to Humboldt	RAUN-NEAL4T1
635034	CLRND 5 161.0	560001	NODAWAYCO 161.0	1	153	158.7	159	3.8%	S1399 to Humboldt	XS635200>635214>\$1
635034	CLRND 5 161.0	560001	NODAWAYCO 161.0	1	153	158.2	158.5	3.8%	S1280 to Humboldt	XS635017>635630>\$1
635034	CLRND 5 161.0	560001	NODAWAYCO 161.0	1	153	157.7	158	4.8%	S1399 to Humboldt	FCS_POSTTRIP
635034	CLRND 5 161.0	560001	NODAWAYCO 161.0	1	153	157.6	158	3.8%	S1399 to Humboldt	FCS_GEN
635034	CLRND 5 161.0	560001	NODAWAYCO 161.0	1	153	157.4	157.8	4.8%	S1399 to Humboldt	XS645001>645451>\$1
635034	CLRND 5 161.0	560001	NODAWAYCO 161.0	1	153	157.6	157.8	3.8%	S1280 to Humboldt	XS635200>635213>\$1
635034	CLRND 5 161.0	560001	NODAWAYCO 161.0	1	153	157.5	157.7	3.8%	S1280 to Humboldt	RAUN-NEAL4T1
635034	CLRND 5 161.0	560001	NODAWAYCO 161.0	1	153	157.5	157.7	3.8%	S1280 to Humboldt	XS635200>635214>\$1

635034	CLRNDA 5 161.0	560001	NODAWAYCO 161.0	1	153	157.3	157.6	3.8%	S1399 to Humboldt	CB3451-54&FC
635034	CLRNDA 5 161.0	560001	NODAWAYCO 161.0	1	153	156.7	157.1	4.8%	S1399 to Humboldt	XS631115>629075>\$1
635034	CLRNDA 5 161.0	560001	NODAWAYCO 161.0	1	153	156.7	157.1	4.8%	S1399 to Humboldt	NC2_GEN
635034	CLRNDA 5 161.0	560001	NODAWAYCO 161.0	1	153	156.5	156.7	3.8%	S1280 to Humboldt	FCS_POSTTRIP
635034	CLRNDA 5 161.0	560001	NODAWAYCO 161.0	1	153	156.5	156.7	3.8%	S1280 to Humboldt	FCS_GEN
635034	CLRNDA 5 161.0	560001	NODAWAYCO 161.0	1	153	156.5	156.7	3.8%	S975 (Humboldt) T4 161-69	FCS_GEN
635034	CLRNDA 5 161.0	560001	NODAWAYCO 161.0	1	153	156.5	156.7	3.8%	S975 (Humboldt) T4 161-69	FCS_POSTTRIP
635034	CLRNDA 5 161.0	560001	NODAWAYCO 161.0	1	153	156.2	156.4	3.8%	S1280 to Humboldt	CB3451-54&FC
635034	CLRNDA 5 161.0	560001	NODAWAYCO 161.0	1	153	156	156.3	4.8%	S1399 to Humboldt	XS645012>645458>\$1
635034	CLRNDA 5 161.0	560001	NODAWAYCO 161.0	1	153	156	156.3	4.8%	S1399 to Humboldt	NC1_GEN
635034	CLRNDA 5 161.0	560001	NODAWAYCO 161.0	1	153	155.7	156.1	4.8%	S1399 to Humboldt	BKR-CPR-3310
635034	CLRNDA 5 161.0	560001	NODAWAYCO 161.0	1	153	155.6	155.9	3.8%	S1280 to Humboldt	XS631115>629075>\$1
635034	CLRNDA 5 161.0	560001	NODAWAYCO 161.0	1	153	155.7	155.9	3.8%	S975 (Humboldt) T4 161-69	XS631115>629075>\$1
635034	CLRNDA 5 161.0	560001	NODAWAYCO 161.0	1	153	155.5	155.8	4.8%	S1399 to Humboldt	XS645011>645458>\$1
635034	CLRNDA 5 161.0	560001	NODAWAYCO 161.0	1	153	155.5	155.7	3.8%	S1280 to Humboldt	NC2_GEN
635034	CLRNDA 5 161.0	560001	NODAWAYCO 161.0	1	153	155.5	155.7	3.8%	S975 (Humboldt) T4 161-69	NC2_GEN
635034	CLRNDA 5 161.0	560001	NODAWAYCO 161.0	1	153	154.7	155.1	4.8%	S1399 to Humboldt	CB3456-58&T4
635034	CLRNDA 5 161.0	560001	NODAWAYCO 161.0	1	153	154.8	155	3.8%	S1280 to Humboldt	XS645012>645458>\$1
635034	CLRNDA 5 161.0	560001	NODAWAYCO 161.0	1	153	154.8	155	3.8%	S1280 to Humboldt	NC1_GEN
635034	CLRNDA 5 161.0	560001	NODAWAYCO 161.0	1	153	154.4	154.7	4.8%	S1399 to Humboldt	CB3455-40&C2
635034	CLRNDA 5 161.0	560001	NODAWAYCO 161.0	1	153	154.4	154.6	3.8%	S1280 to Humboldt	BKR-CPR-3310
635034	CLRNDA 5 161.0	560001	NODAWAYCO 161.0	1	153	154.3	154.5	3.8%	S1280 to Humboldt	XS645011>645458>\$1
635034	CLRNDA 5 161.0	560001	NODAWAYCO 161.0	1	153	154.1	154.4	4.8%	S1399 to Humboldt	XS636640>636641>\$1
635034	CLRNDA 5 161.0	560001	NODAWAYCO 161.0	1	153	154	154.3	4.8%	S1399 to Humboldt	XS631088>629074>\$1
635034	CLRNDA 5 161.0	560001	NODAWAYCO 161.0	1	153	153.9	154.2	4.8%	S1399 to Humboldt	XS645456>645458>\$1
635034	CLRNDA 5 161.0	560001	NODAWAYCO 161.0	1	153	153.9	154.2	3.8%	S975 (Humboldt) T4 161-69	CB3456-58&T4

635034	CLRND 5	161.0	560001	NODAWAYCO	161.0	1	153	153.7	154	3.8%	S1280 to Humboldt	CB3456-58&T4
635034	CLRND 5	161.0	560001	NODAWAYCO	161.0	1	153	153.4	153.8	4.8%	S1399 to Humboldt	XS640139>640277>\$1
635034	CLRND 5	161.0	560001	NODAWAYCO	161.0	1	153	153.5	153.8	4.8%	S1399 to Humboldt	CB3455-40&T3
635034	CLRND 5	161.0	560001	NODAWAYCO	161.0	1	153	153.5	153.8	4.8%	S1399 to Humboldt	BKR-MOR-3302
635034	CLRND 5	161.0	560001	NODAWAYCO	161.0	1	153	153.3	153.6	4.8%	S1399 to Humboldt	XS645455>645740>\$1
635034	CLRND 5	161.0	560001	NODAWAYCO	161.0	1	153	153.4	153.6	3.8%	S1280 to Humboldt	CB3455-40&C2
635034	CLRND 5	161.0	560001	NODAWAYCO	161.0	1	153	153.2	153.5	4.8%	S1399 to Humboldt	BKR-MOR-3308
635034	CLRND 5	161.0	560001	NODAWAYCO	161.0	1	153	153.1	153.4	4.8%	S1399 to Humboldt	CBMOO-CO-MC
635034	CLRND 5	161.0	560001	NODAWAYCO	161.0	1	153	153.1	153.4	3.8%	S975 (Humboldt) T4 161-69	XS645456>645458>\$1
635034	CLRND 5	161.0	560001	NODAWAYCO	161.0	1	153	152.9	153.2	4.8%	S1280 to Humboldt	XS645456>645458>\$1
635034	CLRND 5	161.0	560001	NODAWAYCO	161.0	1	153	152.9	153.2	4.8%	S1399 to Humboldt	XS532772>542982>\$1
635034	CLRND 5	161.0	560001	NODAWAYCO	161.0	1	153	152.6	153	5.7%	S1399 to Humboldt	XS640139>560620>\$1
635034	CLRND 5	161.0	560001	NODAWAYCO	161.0	1	153	152.7	153	4.8%	S1399 to Humboldt	XS635203>635212>\$1
635034	CLRND 5	161.0	560001	NODAWAYCO	161.0	1	153	152.5	152.8	3.8%	S1280 to Humboldt	CB3455-40&T3
635034	CLRND 5	161.0	560001	NODAWAYCO	161.0	1	153	152.5	152.8	3.8%	S1280 to Humboldt	BKR-MOR-3302
635034	CLRND 5	161.0	560001	NODAWAYCO	161.0	1	153	152.4	152.7	3.8%	S1280 to Humboldt	XS640139>640277>\$1
635034	CLRND 5	161.0	560001	NODAWAYCO	161.0	1	153	152.3	152.5	3.8%	S1280 to Humboldt	XS645455>645740>\$1
635034	CLRND 5	161.0	560001	NODAWAYCO	161.0	1	153	152.2	152.4	3.8%	S1280 to Humboldt	BKR-MOR-3308
635034	CLRND 5	161.0	560001	NODAWAYCO	161.0	1	153	152.1	152.3	3.8%	S1280 to Humboldt	CBMOO-CO-MC
635034	CLRND 5	161.0	560001	NODAWAYCO	161.0	1	153	151.8	152.1	4.8%	S1399 to Humboldt	XS652537>659286>\$1
635034	CLRND 5	161.0	560001	NODAWAYCO	161.0	1	153	151.5	151.9	4.8%	S1399 to Humboldt	XS541251>541378>\$1
635034	CLRND 5	161.0	560001	NODAWAYCO	161.0	1	153	151.3	151.6	4.8%	S1399 to Humboldt	XS640139>640009>\$1
635034	CLRND 5	161.0	560001	NODAWAYCO	161.0	1	153	151.3	151.6	4.8%	S1399 to Humboldt	NO5_GEN
635034	CLRND 5	161.0	560001	NODAWAYCO	161.0	1	153	151.2	151.5	4.8%	S1280 to Humboldt	XS640139>560620>\$1
635034	CLRND 5	161.0	560001	NODAWAYCO	161.0	1	153	151.1	151.4	4.8%	S1399 to Humboldt	XS300097>300258>\$2
635034	CLRND 5	161.0	560001	NODAWAYCO	161.0	1	153	151.2	151.4	3.8%	S975 (Humboldt) T4 161-69	XS640139>560620>\$1
635034	CLRND 5	161.0	560001	NODAWAYCO	161.0	1	153	151	151.3	4.8%	S1399 to Humboldt	XS635017>928113>\$1

635034	CLRND 5	161.0	560001	NODAWAYCO	161.0	1	153	150.9	151.3	4.8%	S1399 to Humboldt	XS645025>646211>\$1
635034	CLRND 5	161.0	560001	NODAWAYCO	161.0	1	153	151	151.3	4.8%	S1399 to Humboldt	XS645458>645740>\$1
635034	CLRND 5	161.0	560001	NODAWAYCO	161.0	1	153	150.9	151.2	4.8%	S1399 to Humboldt	CB121120&NO5
635034	CLRND 5	161.0	560001	NODAWAYCO	161.0	1	153	150.8	151.1	4.8%	S1399 to Humboldt	XS652507>652540>\$1
635034	CLRND 5	161.0	560001	NODAWAYCO	161.0	1	153	150.7	151	4.8%	S1399 to Humboldt	XS541199>542972>\$1
635034	CLRND 5	161.0	560001	NODAWAYCO	161.0	1	153	150.6	151	4.8%	S1399 to Humboldt	XS631048>629069>\$1
635034	CLRND 5	161.0	560001	NODAWAYCO	161.0	1	153	150.8	151	3.8%	S1280 to Humboldt	XS652537>659286>\$1
635034	CLRND 5	161.0	560001	NODAWAYCO	161.0	1	153	150.6	150.9	4.8%	S1399 to Humboldt	XS640183>640011>\$1
635034	CLRND 5	161.0	560001	NODAWAYCO	161.0	1	153	150.6	150.9	3.8%	S1280 to Humboldt	XS541251>541378>\$1
635034	CLRND 5	161.0	560001	NODAWAYCO	161.0	1	153	150.4	150.8	4.8%	S1399 to Humboldt	XS631052>629072>\$1
635034	CLRND 5	161.0	560001	NODAWAYCO	161.0	1	153	150.3	150.7	5.7%	S1399 to Humboldt	CB3458-40&CO
635034	CLRND 5	161.0	560001	NODAWAYCO	161.0	1	153	150.4	150.7	3.8%	S1399 to Humboldt	XS635690>635691>\$1
635034	CLRND 5	161.0	560001	NODAWAYCO	161.0	1	153	150.4	150.7	3.8%	S1399 to Humboldt	XS635690>635692>\$2
635034	CLRND 5	161.0	560001	NODAWAYCO	161.0	1	153	150.3	150.7	3.8%	S1399 to Humboldt	XS640184>640010>\$1
635034	CLRND 5	161.0	560001	NODAWAYCO	161.0	1	153	150.2	150.5	4.8%	S1399 to Humboldt	NO4_GEN
635034	CLRND 5	161.0	560001	NODAWAYCO	161.0	1	153	150.2	150.5	4.8%	S1399 to Humboldt	XS541255>541354>\$1
635034	CLRND 5	161.0	560001	NODAWAYCO	161.0	1	153	150.3	150.5	3.8%	S1280 to Humboldt	NO5_GEN
635034	CLRND 5	161.0	560001	NODAWAYCO	161.0	1	153	150	150.4	4.8%	S1399 to Humboldt	XS300076>300087>\$1
635034	CLRND 5	161.0	560001	NODAWAYCO	161.0	1	153	150	150.4	4.8%	S1399 to Humboldt	XS300091>300098>\$1
635034	CLRND 5	161.0	560001	NODAWAYCO	161.0	1	153	150.1	150.4	3.8%	S1280 to Humboldt	XS635017>928113>\$1
635034	CLRND 5	161.0	560001	NODAWAYCO	161.0	1	153	150.1	150.4	3.8%	S1399 to Humboldt	XS300107>301310>\$1
635034	CLRND 5	161.0	560001	NODAWAYCO	161.0	1	153	150	150.4	3.8%	S1399 to Humboldt	XS652519>652557>\$1
635034	CLRND 5	161.0	560001	NODAWAYCO	161.0	1	153	150	150.4	3.8%	S1399 to Humboldt	XS652519>652556>\$1
635034	CLRND 5	161.0	560001	NODAWAYCO	161.0	1	153	150.2	150.4	3.8%	S975 (Humboldt) T4 161-69	XS645458>645740>\$1
635034	CLRND 5	161.0	560001	NODAWAYCO	161.0	1	153	150.1	150.4	3.8%	S1280 to Humboldt	XS300097>300258>\$2
635034	CLRND 5	161.0	560001	NODAWAYCO	161.0	1	153	150	150.3	4.8%	S1399 to Humboldt	XS635001>635022>\$1
635034	CLRND 5	161.0	560001	NODAWAYCO	161.0	1	153	150	150.3	4.8%	S1399 to Humboldt	XS645024>646211>\$1

635034	CLRNDA 5 161.0	560001	NODAWAYCO 161.0	1	153	149.9	150.3	4.8%	S1399 to Humboldt	XS641087>641089>\$1
635034	CLRNDA 5 161.0	560001	NODAWAYCO 161.0	1	153	150	150.3	4.8%	S1399 to Humboldt	CB121199&NO4
635034	CLRNDA 5 161.0	560001	NODAWAYCO 161.0	1	153	150	150.3	3.8%	S1280 to Humboldt	XS645458>645740>\$1
635034	CLRNDA 5 161.0	560001	NODAWAYCO 161.0	1	153	150	150.2	3.8%	S1280 to Humboldt	XS640139>640009>\$1
635034	CLRNDA 5 161.0	560001	NODAWAYCO 161.0	1	153	149.9	150.2	3.8%	S1280 to Humboldt	XS645025>646211>\$1
635034	CLRNDA 5 161.0	560001	NODAWAYCO 161.0	1	153	149.9	150.2	3.8%	S1280 to Humboldt	XS541199>542972>\$1
635034	CLRNDA 5 161.0	560001	NODAWAYCO 161.0	1	153	150	150.2	3.8%	S975 (Humboldt) T4 161-69	XS645025>646211>\$1
635034	CLRNDA 5 161.0	560001	NODAWAYCO 161.0	1	153	149.8	150.1	4.8%	S1399 to Humboldt	XS635000>635001>635025\$1
635034	CLRNDA 5 161.0	560001	NODAWAYCO 161.0	1	153	149.7	150.1	4.8%	S1399 to Humboldt	XS635000>635001>635026\$2
635034	CLRNDA 5 161.0	560001	NODAWAYCO 161.0	1	153	149.7	150.1	4.8%	S1399 to Humboldt	XS635203>635211>\$1
635034	CLRNDA 5 161.0	560001	NODAWAYCO 161.0	1	153	149.8	150.1	4.8%	S1399 to Humboldt	XS636645>345435>\$1
635034	CLRNDA 5 161.0	560001	NODAWAYCO 161.0	1	153	149.8	150.1	4.8%	S1399 to Humboldt	XS652507>652541>\$1
635034	CLRNDA 5 161.0	560001	NODAWAYCO 161.0	1	153	149.7	150.1	4.8%	S1399 to Humboldt	XS631069>652603>\$1
635034	CLRNDA 5 161.0	560001	NODAWAYCO 161.0	1	153	149.9	150.1	3.8%	S1280 to Humboldt	CB121120&NO5
635034	CLRNDA 5 161.0	560001	NODAWAYCO 161.0	1	153	149.7	150	4.8%	S1399 to Humboldt	XS532793>542981>\$1
635034	CLRNDA 5 161.0	560001	NODAWAYCO 161.0	1	153	149.7	150	4.8%	S1399 to Humboldt	XS543028>541354>\$1
635034	CLRNDA 5 161.0	560001	NODAWAYCO 161.0	1	153	149.7	150	3.8%	S975 (Humboldt) T4 161-69	XS631048>629069>\$1
635034	CLRNDA 5 161.0	560001	NODAWAYCO 161.0	1	153	149.6	149.9	4.8%	S1399 to Humboldt	XS635017>635018>\$1
635034	CLRNDA 5 161.0	560001	NODAWAYCO 161.0	1	153	149.6	149.9	4.8%	S1399 to Humboldt	XS635018>635019>\$1
635034	CLRNDA 5 161.0	560001	NODAWAYCO 161.0	1	153	149.5	149.9	4.8%	S1399 to Humboldt	XS640140>646280>\$1
635034	CLRNDA 5 161.0	560001	NODAWAYCO 161.0	1	153	149.6	149.9	4.8%	S1399 to Humboldt	XS645034>646206>645035\$1
635034	CLRNDA 5 161.0	560001	NODAWAYCO 161.0	1	153	149.5	149.9	4.8%	S1399 to Humboldt	NO3_GEN
635034	CLRNDA 5 161.0	560001	NODAWAYCO 161.0	1	153	149.6	149.9	4.8%	S1399 to Humboldt	NO2_GEN
635034	CLRNDA 5 161.0	560001	NODAWAYCO 161.0	1	153	149.6	149.9	4.8%	S1399 to Humboldt	LES7503
635034	CLRNDA 5 161.0	560001	NODAWAYCO 161.0	1	153	149.6	149.9	4.8%	S1399 to Humboldt	CB1280-BUS
635034	CLRNDA 5 161.0	560001	NODAWAYCO 161.0	1	153	149.6	149.9	4.8%	S975 (Humboldt) T4 161-69	CB3458-40&CO
635034	CLRNDA 5 161.0	560001	NODAWAYCO 161.0	1	153	149.6	149.9	3.8%	S1280 to Humboldt	XS631048>629069>\$1

635034	CLRND 5 161.0	560001	NODAWAYCO 161.0	1	153	149.6	149.9	3.8%	S1399 to Humboldt	XS631048>629068>\$1
635034	CLRND 5 161.0	560001	NODAWAYCO 161.0	1	153	149.6	149.9	3.8%	S1399 to Humboldt	XS631048>629067>\$1
635034	CLRND 5 161.0	560001	NODAWAYCO 161.0	1	153	149.5	149.8	4.8%	S1399 to Humboldt	XS300036>301310>\$1
635034	CLRND 5 161.0	560001	NODAWAYCO 161.0	1	153	149.5	149.8	4.8%	S1399 to Humboldt	CB1206T1SC45
635034	CLRND 5 161.0	560001	NODAWAYCO 161.0	1	153	149.5	149.8	3.8%	S975 (Humboldt) T4 161-69	CB1280-BUS
635034	CLRND 5 161.0	560001	NODAWAYCO 161.0	1	153	149.5	149.8	3.8%	S1280 to Humboldt	XS640183>640011>\$1
635034	CLRND 5 161.0	560001	NODAWAYCO 161.0	1	153	149.4	149.7	4.8%	S1399 to Humboldt	XS645022>646211>\$1
635034	CLRND 5 161.0	560001	NODAWAYCO 161.0	1	153	149.4	149.7	4.8%	S1399 to Humboldt	XS645023>646211>\$1
635034	CLRND 5 161.0	560001	NODAWAYCO 161.0	1	153	149.4	149.7	4.8%	S1399 to Humboldt	CB121150&N03
635034	CLRND 5 161.0	560001	NODAWAYCO 161.0	1	153	149.4	149.7	4.8%	S1399 to Humboldt	XS541251>541359>\$1
635034	CLRND 5 161.0	560001	NODAWAYCO 161.0	1	153	149.4	149.7	3.8%	S1280 to Humboldt	XS635690>635691>\$1
635034	CLRND 5 161.0	560001	NODAWAYCO 161.0	1	153	149.4	149.7	3.8%	S1280 to Humboldt	XS635690>635692>\$2
635034	CLRND 5 161.0	560001	NODAWAYCO 161.0	1	153	149.4	149.7	3.8%	S1280 to Humboldt	XS631052>629072>\$1
635034	CLRND 5 161.0	560001	NODAWAYCO 161.0	1	153	149.4	149.7	3.8%	S1399 to Humboldt	CB121150&NO2
635034	CLRND 5 161.0	560001	NODAWAYCO 161.0	1	153	149.3	149.6	4.8%	S1280 to Humboldt	CB3458-40&CO
635034	CLRND 5 161.0	560001	NODAWAYCO 161.0	1	153	149.2	149.6	4.8%	S1399 to Humboldt	XS645042>645740>\$1
635034	CLRND 5 161.0	560001	NODAWAYCO 161.0	1	153	149.2	149.6	4.8%	S1399 to Humboldt	XS645041>645740>\$1
635034	CLRND 5 161.0	560001	NODAWAYCO 161.0	1	153	149.3	149.6	3.8%	S1399 to Humboldt	CBFREM-A
635034	CLRND 5 161.0	560001	NODAWAYCO 161.0	1	153	149.3	149.6	3.8%	S1399 to Humboldt	CASS_CO2_GEN
635034	CLRND 5 161.0	560001	NODAWAYCO 161.0	1	153	149.3	149.6	3.8%	S1399 to Humboldt	CASS_CO1_GEN
635034	CLRND 5 161.0	560001	NODAWAYCO 161.0	1	153	149.4	149.6	3.8%	S975 (Humboldt) T4 161-69	CB1263-BUS
635034	CLRND 5 161.0	560001	NODAWAYCO 161.0	1	153	149.1	149.5	4.8%	S1399 to Humboldt	FRE8_GEN
635034	CLRND 5 161.0	560001	NODAWAYCO 161.0	1	153	149.3	149.5	3.8%	S975 (Humboldt) T4 161-69	XS300091>300098>\$1
635034	CLRND 5 161.0	560001	NODAWAYCO 161.0	1	153	149.2	149.5	3.8%	S1399 to Humboldt	XS631065>629070>\$1
635034	CLRND 5 161.0	560001	NODAWAYCO 161.0	1	153	149.1	149.4	4.8%	S1399 to Humboldt	XS650185>650189>\$1
635034	CLRND 5 161.0	560001	NODAWAYCO 161.0	1	153	149.1	149.4	4.8%	S1399 to Humboldt	XS532766>532773>\$1
635034	CLRND 5 161.0	560001	NODAWAYCO 161.0	1	153	149.1	149.4	4.8%	S1399 to Humboldt	XS532772>542977>\$1

635034	CLRNDA 5	161.0	560001	NODAWAYCO	161.0	1	153	149.1	149.4	4.8%	S1399 to Humboldt	XS652540>652542>\$1
635034	CLRNDA 5	161.0	560001	NODAWAYCO	161.0	1	153	149.1	149.4	4.8%	S1399 to Humboldt	XS652540>652543>\$1
635034	CLRNDA 5	161.0	560001	NODAWAYCO	161.0	1	153	149.1	149.4	4.8%	S1399 to Humboldt	XS652541>652544>\$1
635034	CLRNDA 5	161.0	560001	NODAWAYCO	161.0	1	153	149.2	149.4	3.8%	S1280 to Humboldt	NO4_GEN
635034	CLRNDA 5	161.0	560001	NODAWAYCO	161.0	1	153	149.1	149.4	3.8%	S1280 to Humboldt	XS300076>300087>\$1
635034	CLRNDA 5	161.0	560001	NODAWAYCO	161.0	1	153	149.2	149.4	3.8%	S1280 to Humboldt	XS300107>301310>\$1
635034	CLRNDA 5	161.0	560001	NODAWAYCO	161.0	1	153	149.2	149.4	3.8%	S975 (Humboldt) T4 161-69	XS635001>635022>\$1
635034	CLRNDA 5	161.0	560001	NODAWAYCO	161.0	1	153	149.1	149.4	3.8%	S1280 to Humboldt	XS300091>300098>\$1
635034	CLRNDA 5	161.0	560001	NODAWAYCO	161.0	1	153	148.9	149.3	5.7%	S1399 to Humboldt	XS640139>645458>\$1
635034	CLRNDA 5	161.0	560001	NODAWAYCO	161.0	1	153	149	149.3	4.8%	S1399 to Humboldt	XS647418>647421>\$1
635034	CLRNDA 5	161.0	560001	NODAWAYCO	161.0	1	153	149	149.3	4.8%	S1399 to Humboldt	MCWAG-103-OC
635034	CLRNDA 5	161.0	560001	NODAWAYCO	161.0	1	153	149	149.3	4.8%	S1399 to Humboldt	XS300120>344001>\$1
635034	CLRNDA 5	161.0	560001	NODAWAYCO	161.0	1	153	149	149.3	4.8%	S1399 to Humboldt	XS652603>658001>\$1
635034	CLRNDA 5	161.0	560001	NODAWAYCO	161.0	1	153	149	149.3	4.8%	S1399 to Humboldt	XS652603>658000>\$1
635034	CLRNDA 5	161.0	560001	NODAWAYCO	161.0	1	153	149	149.3	4.8%	S1399 to Humboldt	XS652603>658002>\$1
635034	CLRNDA 5	161.0	560001	NODAWAYCO	161.0	1	153	149	149.3	4.8%	S1399 to Humboldt	XS928113>640139>\$1
635034	CLRNDA 5	161.0	560001	NODAWAYCO	161.0	1	153	149	149.3	4.8%	S1399 to Humboldt	LES0001
635034	CLRNDA 5	161.0	560001	NODAWAYCO	161.0	1	153	148.9	149.3	4.8%	S1399 to Humboldt	CBWAG-T1-103
635034	CLRNDA 5	161.0	560001	NODAWAYCO	161.0	1	153	149	149.3	4.8%	S1399 to Humboldt	XS541369>541368>\$1
635034	CLRNDA 5	161.0	560001	NODAWAYCO	161.0	1	153	149	149.3	3.8%	S1280 to Humboldt	XS635001>635022>\$1
635034	CLRNDA 5	161.0	560001	NODAWAYCO	161.0	1	153	149	149.3	3.8%	S1280 to Humboldt	XS645024>646211>\$1
635034	CLRNDA 5	161.0	560001	NODAWAYCO	161.0	1	153	149	149.3	3.8%	S1280 to Humboldt	XS652519>652556>\$1
635034	CLRNDA 5	161.0	560001	NODAWAYCO	161.0	1	153	149	149.3	3.8%	S1280 to Humboldt	XS652519>652557>\$1
635034	CLRNDA 5	161.0	560001	NODAWAYCO	161.0	1	153	149	149.3	3.8%	S1399 to Humboldt	CBWAG-T2-103
635034	CLRNDA 5	161.0	560001	NODAWAYCO	161.0	1	153	149	149.3	3.8%	S1399 to Humboldt	XS300036>300091>\$1
635034	CLRNDA 5	161.0	560001	NODAWAYCO	161.0	1	153	148.8	149.2	4.8%	S1399 to Humboldt	BKR-103ROKBY
635034	CLRNDA 5	161.0	560001	NODAWAYCO	161.0	1	153	149	149.2	3.8%	S1280 to Humboldt	CB121199&NO4

635034	CLRND 5 161.0	560001	NODAWAYCO 161.0	1	153	148.9	149.2	3.8%	S1280 to Humboldt	XS641087>641089>\$1
635034	CLRND 5 161.0	560001	NODAWAYCO 161.0	1	153	148.9	149.2	3.8%	S1399 to Humboldt	XS631017>629066>\$1
635034	CLRND 5 161.0	560001	NODAWAYCO 161.0	1	153	148.8	149.1	4.8%	S1399 to Humboldt	XS646263>646280>\$1
635034	CLRND 5 161.0	560001	NODAWAYCO 161.0	1	153	148.8	149.1	4.8%	S1399 to Humboldt	NO1_GEN
635034	CLRND 5 161.0	560001	NODAWAYCO 161.0	1	153	148.8	149.1	4.8%	S1399 to Humboldt	LES7505
635034	CLRND 5 161.0	560001	NODAWAYCO 161.0	1	153	148.8	149.1	3.8%	S1280 to Humboldt	XS635000>635001>635025\$1
635034	CLRND 5 161.0	560001	NODAWAYCO 161.0	1	153	148.8	149.1	3.8%	S1399 to Humboldt	XS636400>636645>\$1
635034	CLRND 5 161.0	560001	NODAWAYCO 161.0	1	153	148.9	149.1	3.8%	S975 (Humboldt) T4 161-69	XS635000>635001>635026\$2
635034	CLRND 5 161.0	560001	NODAWAYCO 161.0	1	153	148.7	149	4.8%	S1399 to Humboldt	XS645021>647911>\$1
635034	CLRND 5 161.0	560001	NODAWAYCO 161.0	1	153	148.7	149	4.8%	S1399 to Humboldt	XS652519>652558>\$1
635034	CLRND 5 161.0	560001	NODAWAYCO 161.0	1	153	148.7	149	4.8%	S1399 to Humboldt	XS652510>652546>\$1
635034	CLRND 5 161.0	560001	NODAWAYCO 161.0	1	153	148.8	149	3.8%	S1280 to Humboldt	XS636645>345435>\$1
635034	CLRND 5 161.0	560001	NODAWAYCO 161.0	1	153	148.8	149	3.8%	S1280 to Humboldt	XS631069>652603>\$1
635034	CLRND 5 161.0	560001	NODAWAYCO 161.0	1	153	148.7	149	3.8%	S1399 to Humboldt	XS652509>652548>\$1
635034	CLRND 5 161.0	560001	NODAWAYCO 161.0	1	153	148.7	149	3.8%	S1399 to Humboldt	XS652509>652547>\$1
635034	CLRND 5 161.0	560001	NODAWAYCO 161.0	1	153	148.6	148.9	4.8%	S1399 to Humboldt	XS631109>629071>\$1
635034	CLRND 5 161.0	560001	NODAWAYCO 161.0	1	153	148.6	148.9	4.8%	S1399 to Humboldt	XS631141>270864>\$1
635034	CLRND 5 161.0	560001	NODAWAYCO 161.0	1	153	148.6	148.9	4.8%	S1399 to Humboldt	CB911-BUS
635034	CLRND 5 161.0	560001	NODAWAYCO 161.0	1	153	148.6	148.9	4.8%	S1399 to Humboldt	CB3456-59&T4
635034	CLRND 5 161.0	560001	NODAWAYCO 161.0	1	153	148.5	148.9	4.8%	S1399 to Humboldt	XS631004>629047>\$1
635034	CLRND 5 161.0	560001	NODAWAYCO 161.0	1	153	148.7	148.9	3.8%	S1280 to Humboldt	XS532793>542981>\$1
635034	CLRND 5 161.0	560001	NODAWAYCO 161.0	1	153	148.6	148.9	3.8%	S1280 to Humboldt	LES7503
635034	CLRND 5 161.0	560001	NODAWAYCO 161.0	1	153	148.6	148.9	3.8%	S1399 to Humboldt	XS642071>642067>\$1
635034	CLRND 5 161.0	560001	NODAWAYCO 161.0	1	153	148.6	148.9	3.8%	S1399 to Humboldt	CB1263-BUS
635034	CLRND 5 161.0	560001	NODAWAYCO 161.0	1	153	148.6	148.9	3.8%	S1399 to Humboldt	XS631042>629046>\$1
635034	CLRND 5 161.0	560001	NODAWAYCO 161.0	1	153	148.7	148.9	3.8%	S975 (Humboldt) T4 161-69	LES7503
635034	CLRND 5 161.0	560001	NODAWAYCO 161.0	1	153	148.6	148.9	3.8%	S1399 to Humboldt	XS300068>300087>\$1

635034	CLRND 5	161.0	560001	NODAWAYCO	161.0	1	153	148.5	148.8	4.8%	S1399 to Humboldt	XS631140>631141>\$1
635034	CLRND 5	161.0	560001	NODAWAYCO	161.0	1	153	148.5	148.8	4.8%	S1399 to Humboldt	XS640119>640028>\$1
635034	CLRND 5	161.0	560001	NODAWAYCO	161.0	1	153	148.5	148.8	4.8%	S1399 to Humboldt	XS645456>646206>648256\$1
635034	CLRND 5	161.0	560001	NODAWAYCO	161.0	1	153	148.5	148.8	4.8%	S1399 to Humboldt	XS645458>650189>\$1
635034	CLRND 5	161.0	560001	NODAWAYCO	161.0	1	153	148.6	148.8	3.8%	S1280 to Humboldt	XS300036>301310>\$1
635034	CLRND 5	161.0	560001	NODAWAYCO	161.0	1	153	148.5	148.8	3.8%	S1399 to Humboldt	XS300044>300049>\$1
635034	CLRND 5	161.0	560001	NODAWAYCO	161.0	1	153	148.5	148.8	3.8%	S1399 to Humboldt	SARPY4_GEN
635034	CLRND 5	161.0	560001	NODAWAYCO	161.0	1	153	148.5	148.8	3.8%	S1399 to Humboldt	SARPY5_GEN
635034	CLRND 5	161.0	560001	NODAWAYCO	161.0	1	153	148.5	148.8	3.8%	S1399 to Humboldt	BKR-HLD-3005
635034	CLRND 5	161.0	560001	NODAWAYCO	161.0	1	153	148.6	148.8	3.8%	S1280 to Humboldt	XS645034>646206>645035\$1
635034	CLRND 5	161.0	560001	NODAWAYCO	161.0	1	153	148.6	148.8	3.8%	S1280 to Humboldt	NO3_GEN
635034	CLRND 5	161.0	560001	NODAWAYCO	161.0	1	153	148.6	148.8	3.8%	S1280 to Humboldt	NO2_GEN
635034	CLRND 5	161.0	560001	NODAWAYCO	161.0	1	153	148.6	148.8	3.8%	S975 (Humboldt) T4 161-69	CB1206T1SC45
635034	CLRND 5	161.0	560001	NODAWAYCO	161.0	1	153	148.4	148.7	4.8%	S1399 to Humboldt	XS532768>532796>\$1
635034	CLRND 5	161.0	560001	NODAWAYCO	161.0	1	153	148.3	148.7	4.8%	S1399 to Humboldt	CB1206-T2&T4
635034	CLRND 5	161.0	560001	NODAWAYCO	161.0	1	153	148.4	148.7	4.8%	S1399 to Humboldt	XS541253>541257>\$1
635034	CLRND 5	161.0	560001	NODAWAYCO	161.0	1	153	148.4	148.7	4.8%	S1399 to Humboldt	XS560550>560551>\$1
635034	CLRND 5	161.0	560001	NODAWAYCO	161.0	1	153	148.4	148.7	4.8%	S1399 to Humboldt	XS560550>560551>\$2
635034	CLRND 5	161.0	560001	NODAWAYCO	161.0	1	153	148.4	148.7	3.8%	S1280 to Humboldt	XS645023>646211>\$1
635034	CLRND 5	161.0	560001	NODAWAYCO	161.0	1	153	148.4	148.7	3.8%	S1280 to Humboldt	XS645022>646211>\$1
635034	CLRND 5	161.0	560001	NODAWAYCO	161.0	1	153	148.5	148.7	3.8%	S1280 to Humboldt	CB1206T1SC45
635034	CLRND 5	161.0	560001	NODAWAYCO	161.0	1	153	148.5	148.7	3.8%	S1280 to Humboldt	XS541251>541359>\$1
635034	CLRND 5	161.0	560001	NODAWAYCO	161.0	1	153	148.4	148.7	3.8%	S1399 to Humboldt	XS652512>659275>\$1
635034	CLRND 5	161.0	560001	NODAWAYCO	161.0	1	153	148.5	148.7	3.8%	S1280 to Humboldt	XS635018>635019>\$1
635034	CLRND 5	161.0	560001	NODAWAYCO	161.0	1	153	148.5	148.7	3.8%	S1280 to Humboldt	XS635017>635018>\$1
635034	CLRND 5	161.0	560001	NODAWAYCO	161.0	1	153	148.3	148.6	4.8%	S1399 to Humboldt	XS631134>635870>\$1
635034	CLRND 5	161.0	560001	NODAWAYCO	161.0	1	153	148.3	148.6	4.8%	S1399 to Humboldt	XS640088>640024>\$1

635034	CLRND 5	161.0	560001	NODAWAYCO	161.0	1	153	148.2	148.6	4.8%	S1399 to Humboldt	CB1206-16&T4
635034	CLRND 5	161.0	560001	NODAWAYCO	161.0	1	153	148.2	148.6	4.8%	S1399 to Humboldt	XS543022>543029>\$1
635034	CLRND 5	161.0	560001	NODAWAYCO	161.0	1	153	148.4	148.6	3.8%	S1280 to Humboldt	CB121150&N03
635034	CLRND 5	161.0	560001	NODAWAYCO	161.0	1	153	148.3	148.6	3.8%	S1399 to Humboldt	XS641087>641086>\$1
635034	CLRND 5	161.0	560001	NODAWAYCO	161.0	1	153	148.3	148.6	3.8%	S975 (Humboldt) T4 161-69	XS640139>645458>\$1
635034	CLRND 5	161.0	560001	NODAWAYCO	161.0	1	153	148.3	148.6	3.8%	S1399 to Humboldt	BKR-MOR-3310
635034	CLRND 5	161.0	560001	NODAWAYCO	161.0	1	153	148.3	148.6	3.8%	S1399 to Humboldt	XS541201>345408>\$1
635034	CLRND 5	161.0	560001	NODAWAYCO	161.0	1	153	148.1	148.5	4.8%	S1399 to Humboldt	XS635630>635631>635629\$1
635034	CLRND 5	161.0	560001	NODAWAYCO	161.0	1	153	148.2	148.5	4.8%	S1399 to Humboldt	XS640088>640022>\$1
635034	CLRND 5	161.0	560001	NODAWAYCO	161.0	1	153	148.2	148.5	4.8%	S1399 to Humboldt	XS640088>640023>\$1
635034	CLRND 5	161.0	560001	NODAWAYCO	161.0	1	153	148.2	148.5	4.8%	S1399 to Humboldt	XS640277>650114>\$1
635034	CLRND 5	161.0	560001	NODAWAYCO	161.0	1	153	148.1	148.5	4.8%	S1399 to Humboldt	XS650290>650092>\$1
635034	CLRND 5	161.0	560001	NODAWAYCO	161.0	1	153	148.2	148.5	4.8%	S1399 to Humboldt	XS300039>541199>\$1
635034	CLRND 5	161.0	560001	NODAWAYCO	161.0	1	153	148.2	148.5	4.8%	S1399 to Humboldt	XS532852>532861>\$1
635034	CLRND 5	161.0	560001	NODAWAYCO	161.0	1	153	148.2	148.5	4.8%	S1399 to Humboldt	XS532794>532797>\$1
635034	CLRND 5	161.0	560001	NODAWAYCO	161.0	1	153	148.2	148.5	4.8%	S1399 to Humboldt	XS533332>560141>\$1
635034	CLRND 5	161.0	560001	NODAWAYCO	161.0	1	153	148.1	148.5	4.8%	S1399 to Humboldt	LES9001
635034	CLRND 5	161.0	560001	NODAWAYCO	161.0	1	153	148.2	148.5	4.8%	S1399 to Humboldt	XS542995>300071>\$1
635034	CLRND 5	161.0	560001	NODAWAYCO	161.0	1	153	148.2	148.5	3.8%	S1399 to Humboldt	XS652565>652567>\$1
635034	CLRND 5	161.0	560001	NODAWAYCO	161.0	1	153	148.1	148.5	3.8%	S1399 to Humboldt	LES9004B
635034	CLRND 5	161.0	560001	NODAWAYCO	161.0	1	153	148.2	148.5	3.8%	S1399 to Humboldt	XS541253>541258>\$1
635034	CLRND 5	161.0	560001	NODAWAYCO	161.0	1	153	148.1	148.5	3.8%	S1399 to Humboldt	XS541257>541355>\$1
635034	CLRND 5	161.0	560001	NODAWAYCO	161.0	1	153	148.2	148.5	3.8%	S1280 to Humboldt	XS645041>645740>\$1
635034	CLRND 5	161.0	560001	NODAWAYCO	161.0	1	153	148.2	148.5	3.8%	S1280 to Humboldt	XS645042>645740>\$1
635034	CLRND 5	161.0	560001	NODAWAYCO	161.0	1	153	148.3	148.5	3.8%	S1280 to Humboldt	CBFREM-A
635034	CLRND 5	161.0	560001	NODAWAYCO	161.0	1	153	148.3	148.5	3.8%	S975 (Humboldt) T4 161-69	FRE8_GEN
635034	CLRND 5	161.0	560001	NODAWAYCO	161.0	1	153	148.1	148.4	4.8%	S1399 to Humboldt	XS640125>650114>\$1

635034	CLRNDA 5 161.0	560001	NODAWAYCO 161.0	1	153	148.1	148.4	4.8%	S1399 to Humboldt	XS640278>640019>\$1
635034	CLRNDA 5 161.0	560001	NODAWAYCO 161.0	1	153	148.1	148.4	4.8%	S1399 to Humboldt	XS640278>640020>\$1
635034	CLRNDA 5 161.0	560001	NODAWAYCO 161.0	1	153	148.1	148.4	4.8%	S1399 to Humboldt	TWR-ETR-PH
635034	CLRNDA 5 161.0	560001	NODAWAYCO 161.0	1	153	148.1	148.4	4.8%	S1399 to Humboldt	TWR-ETR-SP
635034	CLRNDA 5 161.0	560001	NODAWAYCO 161.0	1	153	148.1	148.4	4.8%	S1399 to Humboldt	XS532793>300045>\$1
635034	CLRNDA 5 161.0	560001	NODAWAYCO 161.0	1	153	148.1	148.4	4.8%	S1399 to Humboldt	XS533038>533788>533104\$1
635034	CLRNDA 5 161.0	560001	NODAWAYCO 161.0	1	153	148.1	148.4	4.8%	S1399 to Humboldt	XS652541>652545>\$1
635034	CLRNDA 5 161.0	560001	NODAWAYCO 161.0	1	153	148.1	148.4	4.8%	S1399 to Humboldt	BKR-HLD-3003
635034	CLRNDA 5 161.0	560001	NODAWAYCO 161.0	1	153	148.1	148.4	3.8%	S1280 to Humboldt	XS928113>640139>\$1
635034	CLRNDA 5 161.0	560001	NODAWAYCO 161.0	1	153	148.1	148.4	3.8%	S1399 to Humboldt	TWR-ETR-CR
635034	CLRNDA 5 161.0	560001	NODAWAYCO 161.0	1	153	148.1	148.4	3.8%	S1399 to Humboldt	TWR-ETR-RS
635034	CLRNDA 5 161.0	560001	NODAWAYCO 161.0	1	153	148.1	148.4	3.8%	S1399 to Humboldt	XS300097>300258>\$1
635034	CLRNDA 5 161.0	560001	NODAWAYCO 161.0	1	153	148	148.4	3.8%	S1399 to Humboldt	XS300098>344558>\$1
635034	CLRNDA 5 161.0	560001	NODAWAYCO 161.0	1	153	148.1	148.4	3.8%	S1399 to Humboldt	BKR-MOR-3312
635034	CLRNDA 5 161.0	560001	NODAWAYCO 161.0	1	153	148.1	148.4	3.8%	S1399 to Humboldt	XS541254>541258>\$1
635034	CLRNDA 5 161.0	560001	NODAWAYCO 161.0	1	153	148.2	148.4	3.8%	S975 (Humboldt) T4 161-69	XS652540>652543>\$1
635034	CLRNDA 5 161.0	560001	NODAWAYCO 161.0	1	153	148.2	148.4	3.8%	S975 (Humboldt) T4 161-69	XS652540>652542>\$1
635034	CLRNDA 5 161.0	560001	NODAWAYCO 161.0	1	153	148.2	148.4	3.8%	S975 (Humboldt) T4 161-69	XS652541>652544>\$1
635034	CLRNDA 5 161.0	560001	NODAWAYCO 161.0	1	153	148.1	148.4	3.8%	S1280 to Humboldt	XS532772>542977>\$1
635034	CLRNDA 5 161.0	560001	NODAWAYCO 161.0	1	153	148	148.3	4.8%	S1280 to Humboldt	XS640139>645458>\$1
635034	CLRNDA 5 161.0	560001	NODAWAYCO 161.0	1	153	148	148.3	4.8%	S1399 to Humboldt	XS631166>631171>\$1
635034	CLRNDA 5 161.0	560001	NODAWAYCO 161.0	1	153	147.9	148.3	4.8%	S1399 to Humboldt	XS635640>635641>\$1
635034	CLRNDA 5 161.0	560001	NODAWAYCO 161.0	1	153	148	148.3	4.8%	S1399 to Humboldt	XS650275>650002>\$1
635034	CLRNDA 5 161.0	560001	NODAWAYCO 161.0	1	153	148	148.3	4.8%	S1399 to Humboldt	XS646258>646263>\$1
635034	CLRNDA 5 161.0	560001	NODAWAYCO 161.0	1	153	148	148.3	4.8%	S1399 to Humboldt	XS646244>646258>\$1
635034	CLRNDA 5 161.0	560001	NODAWAYCO 161.0	1	153	148	148.3	4.8%	S1399 to Humboldt	XS532873>530592>\$1
635034	CLRNDA 5 161.0	560001	NODAWAYCO 161.0	1	153	148	148.3	4.8%	S1399 to Humboldt	XS652573>659206>\$1

635034	CLRNDA 5	161.0	560001	NODAWAYCO	161.0	1	153	148	148.3	4.8%	S1399 to Humboldt	LES7501
635034	CLRNDA 5	161.0	560001	NODAWAYCO	161.0	1	153	148	148.3	4.8%	S1399 to Humboldt	D-CIRCUIT#12
635034	CLRNDA 5	161.0	560001	NODAWAYCO	161.0	1	153	148	148.3	4.8%	S1399 to Humboldt	XS560332>560333>\$1
635034	CLRNDA 5	161.0	560001	NODAWAYCO	161.0	1	153	148	148.3	4.8%	S1399 to Humboldt	XS560333>560334>\$1
635034	CLRNDA 5	161.0	560001	NODAWAYCO	161.0	1	153	148.1	148.3	3.8%	S1280 to Humboldt	XS640140>646280>\$1
635034	CLRNDA 5	161.0	560001	NODAWAYCO	161.0	1	153	148	148.3	3.8%	S1280 to Humboldt	XS647418>647421>\$1
635034	CLRNDA 5	161.0	560001	NODAWAYCO	161.0	1	153	148.1	148.3	3.8%	S1280 to Humboldt	XS646263>646280>\$1
635034	CLRNDA 5	161.0	560001	NODAWAYCO	161.0	1	153	148.1	148.3	3.8%	S1280 to Humboldt	MCWAG-103-OC
635034	CLRNDA 5	161.0	560001	NODAWAYCO	161.0	1	153	148.1	148.3	3.8%	S1280 to Humboldt	XS300036>300091>\$1
635034	CLRNDA 5	161.0	560001	NODAWAYCO	161.0	1	153	148.1	148.3	3.8%	S1280 to Humboldt	XS652603>658002>\$1
635034	CLRNDA 5	161.0	560001	NODAWAYCO	161.0	1	153	148.1	148.3	3.8%	S1280 to Humboldt	XS652541>652544>\$1
635034	CLRNDA 5	161.0	560001	NODAWAYCO	161.0	1	153	148.1	148.3	3.8%	S1280 to Humboldt	CB1280-BUS
635034	CLRNDA 5	161.0	560001	NODAWAYCO	161.0	1	153	148	148.3	3.8%	S1280 to Humboldt	CBWAG-T2-103
635034	CLRNDA 5	161.0	560001	NODAWAYCO	161.0	1	153	148.1	148.3	3.8%	S1280 to Humboldt	XS541369>541368>\$1
635034	CLRNDA 5	161.0	560001	NODAWAYCO	161.0	1	153	148	148.3	3.8%	S1399 to Humboldt	XS636610>270866>\$1
635034	CLRNDA 5	161.0	560001	NODAWAYCO	161.0	1	153	148	148.3	3.8%	S1399 to Humboldt	XS650275>650003>\$1
635034	CLRNDA 5	161.0	560001	NODAWAYCO	161.0	1	153	148	148.3	3.8%	S1399 to Humboldt	XS650275>650004>\$1
635034	CLRNDA 5	161.0	560001	NODAWAYCO	161.0	1	153	148	148.3	3.8%	S1399 to Humboldt	XS652509>652549>\$1
635034	CLRNDA 5	161.0	560001	NODAWAYCO	161.0	1	153	148	148.3	3.8%	S1399 to Humboldt	BKR-CE-3306
635034	CLRNDA 5	161.0	560001	NODAWAYCO	161.0	1	153	148.1	148.3	3.8%	S975 (Humboldt) T4 161-69	XS652603>658001>\$1
635034	CLRNDA 5	161.0	560001	NODAWAYCO	161.0	1	153	148.1	148.3	3.8%	S975 (Humboldt) T4 161-69	XS652603>658000>\$1
635034	CLRNDA 5	161.0	560001	NODAWAYCO	161.0	1	153	148.1	148.3	3.8%	S975 (Humboldt) T4 161-69	XS300120>344001>\$1
635034	CLRNDA 5	161.0	560001	NODAWAYCO	161.0	1	153	147.9	148.2	4.8%	S1399 to Humboldt	XS631115>631118>\$1
635034	CLRNDA 5	161.0	560001	NODAWAYCO	161.0	1	153	147.9	148.2	4.8%	S1399 to Humboldt	XS631118>630044>\$1
635034	CLRNDA 5	161.0	560001	NODAWAYCO	161.0	1	153	147.9	148.2	4.8%	S1399 to Humboldt	XS631122>631176>\$1
635034	CLRNDA 5	161.0	560001	NODAWAYCO	161.0	1	153	147.9	148.2	4.8%	S1399 to Humboldt	XS635600>635630>\$1
635034	CLRNDA 5	161.0	560001	NODAWAYCO	161.0	1	153	147.9	148.2	4.8%	S1399 to Humboldt	XS631112>344001>\$1

635034	CLRND 5	161.0	560001	NODAWAYCO	161.0	1	153	147.9	148.2	4.8%	S1399 to Humboldt	XS635003>635004>\$1
635034	CLRND 5	161.0	560001	NODAWAYCO	161.0	1	153	147.9	148.2	4.8%	S1399 to Humboldt	XS631142>636420>\$1
635034	CLRND 5	161.0	560001	NODAWAYCO	161.0	1	153	147.9	148.2	4.8%	S1399 to Humboldt	XS636400>636420>\$1
635034	CLRND 5	161.0	560001	NODAWAYCO	161.0	1	153	147.9	148.2	4.8%	S1399 to Humboldt	XS645459>646209>648259\$1
635034	CLRND 5	161.0	560001	NODAWAYCO	161.0	1	153	147.8	148.2	4.8%	S1399 to Humboldt	XS647963>647977>\$1
635034	CLRND 5	161.0	560001	NODAWAYCO	161.0	1	153	147.9	148.2	4.8%	S1399 to Humboldt	XS650242>640278>\$1
635034	CLRND 5	161.0	560001	NODAWAYCO	161.0	1	153	147.8	148.2	4.8%	S1399 to Humboldt	MC1221-31-55
635034	CLRND 5	161.0	560001	NODAWAYCO	161.0	1	153	147.9	148.2	4.8%	S1399 to Humboldt	XS300036>344923>\$1
635034	CLRND 5	161.0	560001	NODAWAYCO	161.0	1	153	147.9	148.2	4.8%	S1399 to Humboldt	XS532871>539679>\$1
635034	CLRND 5	161.0	560001	NODAWAYCO	161.0	1	153	147.9	148.2	4.8%	S1399 to Humboldt	XS532791>532797>\$1
635034	CLRND 5	161.0	560001	NODAWAYCO	161.0	1	153	147.9	148.2	4.8%	S1399 to Humboldt	XS652511>652576>\$1
635034	CLRND 5	161.0	560001	NODAWAYCO	161.0	1	153	147.8	148.2	4.8%	S1399 to Humboldt	XS652537>601007>\$1
635034	CLRND 5	161.0	560001	NODAWAYCO	161.0	1	153	147.9	148.2	4.8%	S1399 to Humboldt	XS652466>659284>\$1
635034	CLRND 5	161.0	560001	NODAWAYCO	161.0	1	153	147.9	148.2	4.8%	S1399 to Humboldt	XS652511>652575>\$1
635034	CLRND 5	161.0	560001	NODAWAYCO	161.0	1	153	147.9	148.2	4.8%	S1399 to Humboldt	XS652511>652577>\$1
635034	CLRND 5	161.0	560001	NODAWAYCO	161.0	1	153	147.9	148.2	4.8%	S1399 to Humboldt	CB1255-21&T1
635034	CLRND 5	161.0	560001	NODAWAYCO	161.0	1	153	147.9	148.2	4.8%	S1399 to Humboldt	LES4202
635034	CLRND 5	161.0	560001	NODAWAYCO	161.0	1	153	147.9	148.2	4.8%	S1399 to Humboldt	LES4203
635034	CLRND 5	161.0	560001	NODAWAYCO	161.0	1	153	147.9	148.2	4.8%	S1399 to Humboldt	D-CIRCUIT#9B
635034	CLRND 5	161.0	560001	NODAWAYCO	161.0	1	153	147.9	148.2	4.8%	S1399 to Humboldt	BKR-HLD-3006
635034	CLRND 5	161.0	560001	NODAWAYCO	161.0	1	153	147.8	148.2	4.8%	S1399 to Humboldt	XS541314>300034>\$1
635034	CLRND 5	161.0	560001	NODAWAYCO	161.0	1	153	147.9	148.2	4.8%	S1399 to Humboldt	XS541255>541355>\$1
635034	CLRND 5	161.0	560001	NODAWAYCO	161.0	1	153	148	148.2	3.8%	S1280 to Humboldt	LES0001
635034	CLRND 5	161.0	560001	NODAWAYCO	161.0	1	153	148	148.2	3.8%	S1280 to Humboldt	CBWAG-T1-103
635034	CLRND 5	161.0	560001	NODAWAYCO	161.0	1	153	147.9	148.2	3.8%	S1399 to Humboldt	XS635201>635202>\$1
635034	CLRND 5	161.0	560001	NODAWAYCO	161.0	1	153	148	148.2	3.8%	S975 (Humboldt) T4 161-69	XS631017>629066>\$1
635034	CLRND 5	161.0	560001	NODAWAYCO	161.0	1	153	147.9	148.2	3.8%	S1399 to Humboldt	CB1209-T1&T3

635034	CLRNDA 5	161.0	560001	NODAWAYCO	161.0	1	153	147.9	148.2	3.8%	S1399 to Humboldt	XS541314>505502>\$1
635034	CLRNDA 5	161.0	560001	NODAWAYCO	161.0	1	153	147.9	148.2	3.8%	S975 (Humboldt) T4 161-69	LES7505
635034	CLRNDA 5	161.0	560001	NODAWAYCO	161.0	1	153	147.8	148.1	4.8%	S1399 to Humboldt	XS635041>635042>\$1
635034	CLRNDA 5	161.0	560001	NODAWAYCO	161.0	1	153	147.8	148.1	4.8%	S1399 to Humboldt	XS635041>635043>\$2
635034	CLRNDA 5	161.0	560001	NODAWAYCO	161.0	1	153	147.8	148.1	4.8%	S1399 to Humboldt	XS635633>635636>\$1
635034	CLRNDA 5	161.0	560001	NODAWAYCO	161.0	1	153	147.8	148.1	4.8%	S1399 to Humboldt	XS635633>635634>\$1
635034	CLRNDA 5	161.0	560001	NODAWAYCO	161.0	1	153	147.7	148.1	4.8%	S1399 to Humboldt	XS636029>636034>\$1
635034	CLRNDA 5	161.0	560001	NODAWAYCO	161.0	1	153	147.8	148.1	4.8%	S1399 to Humboldt	XS635310>635311>\$1
635034	CLRNDA 5	161.0	560001	NODAWAYCO	161.0	1	153	147.8	148.1	4.8%	S1399 to Humboldt	XS635330>635331>\$1
635034	CLRNDA 5	161.0	560001	NODAWAYCO	161.0	1	153	147.8	148.1	4.8%	S1399 to Humboldt	XS635202>635300>\$1
635034	CLRNDA 5	161.0	560001	NODAWAYCO	161.0	1	153	147.8	148.1	4.8%	S1399 to Humboldt	XS640169>640208>\$1
635034	CLRNDA 5	161.0	560001	NODAWAYCO	161.0	1	153	147.7	148.1	4.8%	S1399 to Humboldt	XS640325>640326>640327\$1
635034	CLRNDA 5	161.0	560001	NODAWAYCO	161.0	1	153	147.7	148.1	4.8%	S1399 to Humboldt	XS646221>646255>\$1
635034	CLRNDA 5	161.0	560001	NODAWAYCO	161.0	1	153	147.8	148.1	4.8%	S1399 to Humboldt	XS300034>300555>\$1
635034	CLRNDA 5	161.0	560001	NODAWAYCO	161.0	1	153	147.8	148.1	4.8%	S1399 to Humboldt	XS532863>532874>\$1
635034	CLRNDA 5	161.0	560001	NODAWAYCO	161.0	1	153	147.8	148.1	4.8%	S1399 to Humboldt	XS532773>532873>532813\$1
635034	CLRNDA 5	161.0	560001	NODAWAYCO	161.0	1	153	147.7	148.1	4.8%	S1399 to Humboldt	XS533254>533255>\$1
635034	CLRNDA 5	161.0	560001	NODAWAYCO	161.0	1	153	147.8	148.1	4.8%	S1399 to Humboldt	XS652607>659295>\$1
635034	CLRNDA 5	161.0	560001	NODAWAYCO	161.0	1	153	147.8	148.1	4.8%	S1399 to Humboldt	CB1209-50&T3
635034	CLRNDA 5	161.0	560001	NODAWAYCO	161.0	1	153	147.7	148.1	4.8%	S1399 to Humboldt	CB963-BUS977
635034	CLRNDA 5	161.0	560001	NODAWAYCO	161.0	1	153	147.8	148.1	4.8%	S1399 to Humboldt	FRE7_GEN
635034	CLRNDA 5	161.0	560001	NODAWAYCO	161.0	1	153	147.8	148.1	4.8%	S1399 to Humboldt	CB1221-55&T9
635034	CLRNDA 5	161.0	560001	NODAWAYCO	161.0	1	153	147.8	148.1	4.8%	S1399 to Humboldt	CB963BUS1263
635034	CLRNDA 5	161.0	560001	NODAWAYCO	161.0	1	153	147.8	148.1	4.8%	S1399 to Humboldt	CB3456-58&CB
635034	CLRNDA 5	161.0	560001	NODAWAYCO	161.0	1	153	147.8	148.1	4.8%	S1399 to Humboldt	CB3459-BUS
635034	CLRNDA 5	161.0	560001	NODAWAYCO	161.0	1	153	147.8	148.1	4.8%	S1399 to Humboldt	CB3454-51&T1
635034	CLRNDA 5	161.0	560001	NODAWAYCO	161.0	1	153	147.8	148.1	4.8%	S1399 to Humboldt	XS542972>541201>\$1

635034	CLRNDA 5	161.0	560001	NODAWAYCO	161.0	1	153	147.7	148.1	4.8%	S1399 to Humboldt	XS631087>631088>\$1
635034	CLRNDA 5	161.0	560001	NODAWAYCO	161.0	1	153	147.8	148.1	3.8%	S1280 to Humboldt	LES7505
635034	CLRNDA 5	161.0	560001	NODAWAYCO	161.0	1	153	147.8	148.1	3.8%	S1280 to Humboldt	CB1263-BUS
635034	CLRNDA 5	161.0	560001	NODAWAYCO	161.0	1	153	147.8	148.1	3.8%	S1280 to Humboldt	BKR-103ROKBY
635034	CLRNDA 5	161.0	560001	NODAWAYCO	161.0	1	153	147.8	148.1	3.8%	S1399 to Humboldt	XS635310>635320>\$1
635034	CLRNDA 5	161.0	560001	NODAWAYCO	161.0	1	153	147.8	148.1	3.8%	S1399 to Humboldt	XS647401>647977>\$1
635034	CLRNDA 5	161.0	560001	NODAWAYCO	161.0	1	153	147.8	148.1	3.8%	S1399 to Humboldt	S3454T1 AUTO
635034	CLRNDA 5	161.0	560001	NODAWAYCO	161.0	1	153	147.8	148.1	3.8%	S1399 to Humboldt	XS532865>539639>\$1
635034	CLRNDA 5	161.0	560001	NODAWAYCO	161.0	1	153	147.7	148.1	3.8%	S1399 to Humboldt	XS532766>532770>\$1
635034	CLRNDA 5	161.0	560001	NODAWAYCO	161.0	1	153	147.8	148.1	3.8%	S1399 to Humboldt	CB1206CBSC45
635034	CLRNDA 5	161.0	560001	NODAWAYCO	161.0	1	153	147.8	148.1	3.8%	S1399 to Humboldt	CB1254-BUS
635034	CLRNDA 5	161.0	560001	NODAWAYCO	161.0	1	153	147.8	148.1	3.8%	S1399 to Humboldt	XS631053>629073>\$1
635034	CLRNDA 5	161.0	560001	NODAWAYCO	161.0	1	153	147.9	148.1	3.8%	S975 (Humboldt) T4 161-69	XS636400>636645>\$1
635034	CLRNDA 5	161.0	560001	NODAWAYCO	161.0	1	153	147.7	148	4.8%	S1399 to Humboldt	XS635350>635353>\$2
635034	CLRNDA 5	161.0	560001	NODAWAYCO	161.0	1	153	147.7	148	4.8%	S1399 to Humboldt	XS635650>635690>\$1
635034	CLRNDA 5	161.0	560001	NODAWAYCO	161.0	1	153	147.6	148	4.8%	S1399 to Humboldt	XS635001>635002>\$1
635034	CLRNDA 5	161.0	560001	NODAWAYCO	161.0	1	153	147.7	148	4.8%	S1399 to Humboldt	XS631171>631172>\$1
635034	CLRNDA 5	161.0	560001	NODAWAYCO	161.0	1	153	147.7	148	4.8%	S1399 to Humboldt	XS635001>635002>\$2
635034	CLRNDA 5	161.0	560001	NODAWAYCO	161.0	1	153	147.7	148	4.8%	S1399 to Humboldt	XS631171>631173>\$1
635034	CLRNDA 5	161.0	560001	NODAWAYCO	161.0	1	153	147.7	148	4.8%	S1399 to Humboldt	XS635650>635651>\$1
635034	CLRNDA 5	161.0	560001	NODAWAYCO	161.0	1	153	147.7	148	4.8%	S1399 to Humboldt	XS636030>636037>\$1
635034	CLRNDA 5	161.0	560001	NODAWAYCO	161.0	1	153	147.7	148	4.8%	S1399 to Humboldt	XS635320>635319>\$1
635034	CLRNDA 5	161.0	560001	NODAWAYCO	161.0	1	153	147.7	148	4.8%	S1399 to Humboldt	XS635310>635330>\$1
635034	CLRNDA 5	161.0	560001	NODAWAYCO	161.0	1	153	147.7	148	4.8%	S1399 to Humboldt	XS635320>635318>\$1
635034	CLRNDA 5	161.0	560001	NODAWAYCO	161.0	1	153	147.7	148	4.8%	S1399 to Humboldt	XS635350>635351>\$1
635034	CLRNDA 5	161.0	560001	NODAWAYCO	161.0	1	153	147.7	148	4.8%	S1399 to Humboldt	XS640088>640278>\$1
635034	CLRNDA 5	161.0	560001	NODAWAYCO	161.0	1	153	147.7	148	4.8%	S1399 to Humboldt	XS636235>636234>\$2

635034	CLRND 5 161.0	560001	NODAWAYCO 161.0	1	153	147.7	148	4.8%	S1399 to Humboldt	XS636400>636630>\$1
635034	CLRND 5 161.0	560001	NODAWAYCO 161.0	1	153	147.7	148	4.8%	S1399 to Humboldt	XS640267>640287>\$1
635034	CLRND 5 161.0	560001	NODAWAYCO 161.0	1	153	147.7	148	4.8%	S1399 to Humboldt	XS640404>652573>\$1
635034	CLRND 5 161.0	560001	NODAWAYCO 161.0	1	153	147.7	148	4.8%	S1399 to Humboldt	XS640396>652573>\$1
635034	CLRND 5 161.0	560001	NODAWAYCO 161.0	1	153	147.6	148	4.8%	S1399 to Humboldt	XS640396>640397>640399\$1
635034	CLRND 5 161.0	560001	NODAWAYCO 161.0	1	153	147.6	148	4.8%	S1399 to Humboldt	XS646263>647111>648263\$1
635034	CLRND 5 161.0	560001	NODAWAYCO 161.0	1	153	147.7	148	4.8%	S1399 to Humboldt	XS650275>650001>\$1
635034	CLRND 5 161.0	560001	NODAWAYCO 161.0	1	153	147.7	148	4.8%	S1399 to Humboldt	XS645455>646255>648255\$1
635034	CLRND 5 161.0	560001	NODAWAYCO 161.0	1	153	147.7	148	4.8%	S1399 to Humboldt	XS645455>646255>648355\$1
635034	CLRND 5 161.0	560001	NODAWAYCO 161.0	1	153	147.6	148	4.8%	S1399 to Humboldt	XS300071>300108>\$1
635034	CLRND 5 161.0	560001	NODAWAYCO 161.0	1	153	147.7	148	4.8%	S1399 to Humboldt	S1263T1 AUTO
635034	CLRND 5 161.0	560001	NODAWAYCO 161.0	1	153	147.7	148	4.8%	S1399 to Humboldt	S1221 AUTOV2
635034	CLRND 5 161.0	560001	NODAWAYCO 161.0	1	153	147.7	148	4.8%	S1399 to Humboldt	XS532873>532874>\$1
635034	CLRND 5 161.0	560001	NODAWAYCO 161.0	1	153	147.7	148	4.8%	S1399 to Humboldt	XS532913>533217>532942\$1
635034	CLRND 5 161.0	560001	NODAWAYCO 161.0	1	153	147.7	148	4.8%	S1399 to Humboldt	XS300320>548808>\$1
635034	CLRND 5 161.0	560001	NODAWAYCO 161.0	1	153	147.7	148	4.8%	S1399 to Humboldt	XS300110>300320>\$1
635034	CLRND 5 161.0	560001	NODAWAYCO 161.0	1	153	147.7	148	4.8%	S1399 to Humboldt	XS533217>533337>\$1
635034	CLRND 5 161.0	560001	NODAWAYCO 161.0	1	153	147.7	148	4.8%	S1399 to Humboldt	XS533027>533028>\$1
635034	CLRND 5 161.0	560001	NODAWAYCO 161.0	1	153	147.7	148	4.8%	S1399 to Humboldt	CB963-BUSAUB
635034	CLRND 5 161.0	560001	NODAWAYCO 161.0	1	153	147.7	148	4.8%	S1399 to Humboldt	FRE6_GEN
635034	CLRND 5 161.0	560001	NODAWAYCO 161.0	1	153	147.7	148	4.8%	S1399 to Humboldt	CB1255-59&T3
635034	CLRND 5 161.0	560001	NODAWAYCO 161.0	1	153	147.7	148	4.8%	S1399 to Humboldt	CB1221-31&T9
635034	CLRND 5 161.0	560001	NODAWAYCO 161.0	1	153	147.7	148	4.8%	S1399 to Humboldt	XS541207>541240>\$1
635034	CLRND 5 161.0	560001	NODAWAYCO 161.0	1	153	147.7	148	4.8%	S1399 to Humboldt	XS543028>543029>\$1
635034	CLRND 5 161.0	560001	NODAWAYCO 161.0	1	153	147.7	148	4.8%	S1399 to Humboldt	XS541240>301342>\$1
635034	CLRND 5 161.0	560001	NODAWAYCO 161.0	1	153	147.6	148	4.8%	S1399 to Humboldt	XS541208>301342>\$1
635034	CLRND 5 161.0	560001	NODAWAYCO 161.0	1	153	147.7	148	4.8%	S1399 to Humboldt	XS541254>541256>\$1

635034	CLRND 5 161.0	560001	NODAWAYCO 161.0	1	153	147.7	148	4.8%	S1399 to Humboldt	XS541228>541229>\$1
635034	CLRND 5 161.0	560001	NODAWAYCO 161.0	1	153	147.7	148	4.8%	S1399 to Humboldt	XS631086>631087>\$1
635034	CLRND 5 161.0	560001	NODAWAYCO 161.0	1	153	147.7	148	3.8%	S1280 to Humboldt	XS652519>652558>\$1
635034	CLRND 5 161.0	560001	NODAWAYCO 161.0	1	153	147.7	148	3.8%	S1399 to Humboldt	XS636029>636028>\$1
635034	CLRND 5 161.0	560001	NODAWAYCO 161.0	1	153	147.7	148	3.8%	S1399 to Humboldt	XS636630>636640>\$1
635034	CLRND 5 161.0	560001	NODAWAYCO 161.0	1	153	147.7	148	3.8%	S1399 to Humboldt	XS636235>636237>\$1
635034	CLRND 5 161.0	560001	NODAWAYCO 161.0	1	153	147.7	148	3.8%	S1399 to Humboldt	XS645454>646254>648254\$1
635034	CLRND 5 161.0	560001	NODAWAYCO 161.0	1	153	147.7	148	3.8%	S1399 to Humboldt	XS532765>533163>532804\$1
635034	CLRND 5 161.0	560001	NODAWAYCO 161.0	1	153	147.6	148	3.8%	S1399 to Humboldt	XS532771>532773>\$1
635034	CLRND 5 161.0	560001	NODAWAYCO 161.0	1	153	147.6	148	3.8%	S1399 to Humboldt	XS533157>533189>\$1
635034	CLRND 5 161.0	560001	NODAWAYCO 161.0	1	153	147.7	148	3.8%	S1399 to Humboldt	XS928113>928115>\$1
635034	CLRND 5 161.0	560001	NODAWAYCO 161.0	1	153	147.6	148	3.8%	S1399 to Humboldt	XS631076>345827>\$1
635034	CLRND 5 161.0	560001	NODAWAYCO 161.0	1	153	147.6	148	3.8%	S1399 to Humboldt	XS631075>631076>\$1
635034	CLRND 5 161.0	560001	NODAWAYCO 161.0	1	153	147.8	148	3.8%	S975 (Humboldt) T4 161-69	XS652509>652547>\$1
635034	CLRND 5 161.0	560001	NODAWAYCO 161.0	1	153	147.8	148	3.8%	S975 (Humboldt) T4 161-69	XS652509>652548>\$1
635034	CLRND 5 161.0	560001	NODAWAYCO 161.0	1	153	147.7	148	3.8%	S975 (Humboldt) T4 161-69	XS642071>642067>\$1
635034	CLRND 5 161.0	560001	NODAWAYCO 161.0	1	153	147.8	148	3.8%	S975 (Humboldt) T4 161-69	XS300068>300087>\$1
635034	CLRND 5 161.0	560001	NODAWAYCO 161.0	1	153	147.6	147.9	4.8%	S1399 to Humboldt	XS631115>631143>\$1
635034	CLRND 5 161.0	560001	NODAWAYCO 161.0	1	153	147.6	147.9	4.8%	S1399 to Humboldt	XS635600>635601>635599\$1
635034	CLRND 5 161.0	560001	NODAWAYCO 161.0	1	153	147.6	147.9	4.8%	S1399 to Humboldt	XS631112>630033>\$1
635034	CLRND 5 161.0	560001	NODAWAYCO 161.0	1	153	147.6	147.9	4.8%	S1399 to Humboldt	XS631177>615122>\$1
635034	CLRND 5 161.0	560001	NODAWAYCO 161.0	1	153	147.6	147.9	4.8%	S1399 to Humboldt	XS631176>631177>\$1
635034	CLRND 5 161.0	560001	NODAWAYCO 161.0	1	153	147.6	147.9	4.8%	S1399 to Humboldt	XS631176>605613>\$1
635034	CLRND 5 161.0	560001	NODAWAYCO 161.0	1	153	147.6	147.9	4.8%	S1399 to Humboldt	XS631139>631142>\$1
635034	CLRND 5 161.0	560001	NODAWAYCO 161.0	1	153	147.6	147.9	4.8%	S1399 to Humboldt	XS631139>631140>\$1
635034	CLRND 5 161.0	560001	NODAWAYCO 161.0	1	153	147.6	147.9	4.8%	S1399 to Humboldt	XS631143>635730>\$1

635034	CLRND 5	161.0	560001	NODAWAYCO	161.0	1	153	147.6	147.9	4.8%	S1399 to Humboldt	XS635300>635330>\$1
635034	CLRND 5	161.0	560001	NODAWAYCO	161.0	1	153	147.6	147.9	4.8%	S1399 to Humboldt	XS631102>631124>\$1
635034	CLRND 5	161.0	560001	NODAWAYCO	161.0	1	153	147.5	147.9	4.8%	S1399 to Humboldt	XS636029>636036>\$1
635034	CLRND 5	161.0	560001	NODAWAYCO	161.0	1	153	147.5	147.9	4.8%	S1399 to Humboldt	XS640111>640278>\$1
635034	CLRND 5	161.0	560001	NODAWAYCO	161.0	1	153	147.6	147.9	4.8%	S1399 to Humboldt	XS640088>640111>\$1
635034	CLRND 5	161.0	560001	NODAWAYCO	161.0	1	153	147.6	147.9	4.8%	S1399 to Humboldt	XS640050>640051>\$1
635034	CLRND 5	161.0	560001	NODAWAYCO	161.0	1	153	147.6	147.9	4.8%	S1399 to Humboldt	XS640171>640278>\$1
635034	CLRND 5	161.0	560001	NODAWAYCO	161.0	1	153	147.5	147.9	4.8%	S1399 to Humboldt	XS640050>640096>\$1
635034	CLRND 5	161.0	560001	NODAWAYCO	161.0	1	153	147.6	147.9	4.8%	S1399 to Humboldt	XS636400>636401>636406\$1
635034	CLRND 5	161.0	560001	NODAWAYCO	161.0	1	153	147.6	147.9	4.8%	S1399 to Humboldt	XS640169>640218>\$1
635034	CLRND 5	161.0	560001	NODAWAYCO	161.0	1	153	147.6	147.9	4.8%	S1399 to Humboldt	XS640096>640381>\$1
635034	CLRND 5	161.0	560001	NODAWAYCO	161.0	1	153	147.5	147.9	4.8%	S1399 to Humboldt	XS640125>640342>\$1
635034	CLRND 5	161.0	560001	NODAWAYCO	161.0	1	153	147.6	147.9	4.8%	S1399 to Humboldt	XS640093>640286>\$1
635034	CLRND 5	161.0	560001	NODAWAYCO	161.0	1	153	147.6	147.9	4.8%	S1399 to Humboldt	XS640139>640140>640142\$1
635034	CLRND 5	161.0	560001	NODAWAYCO	161.0	1	153	147.5	147.9	4.8%	S1399 to Humboldt	XS640139>640140>643172\$1
635034	CLRND 5	161.0	560001	NODAWAYCO	161.0	1	153	147.5	147.9	4.8%	S1399 to Humboldt	XS640404>652484>\$1
635034	CLRND 5	161.0	560001	NODAWAYCO	161.0	1	153	147.6	147.9	4.8%	S1399 to Humboldt	XS640259>640284>\$1
635034	CLRND 5	161.0	560001	NODAWAYCO	161.0	1	153	147.6	147.9	4.8%	S1399 to Humboldt	XS640267>640381>\$1
635034	CLRND 5	161.0	560001	NODAWAYCO	161.0	1	153	147.5	147.9	4.8%	S1399 to Humboldt	XS647111>647963>\$1
635034	CLRND 5	161.0	560001	NODAWAYCO	161.0	1	153	147.6	147.9	4.8%	S1399 to Humboldt	XS646227>646231>\$1
635034	CLRND 5	161.0	560001	NODAWAYCO	161.0	1	153	147.6	147.9	4.8%	S1399 to Humboldt	XS646249>646254>\$1
635034	CLRND 5	161.0	560001	NODAWAYCO	161.0	1	153	147.6	147.9	4.8%	S1399 to Humboldt	XS647417>647421>\$1
635034	CLRND 5	161.0	560001	NODAWAYCO	161.0	1	153	147.5	147.9	4.8%	S1399 to Humboldt	TWR-SCH-CM
635034	CLRND 5	161.0	560001	NODAWAYCO	161.0	1	153	147.5	147.9	4.8%	S1399 to Humboldt	XS300058>345034>\$1
635034	CLRND 5	161.0	560001	NODAWAYCO	161.0	1	153	147.6	147.9	4.8%	S1399 to Humboldt	TWR-SCH-CC
635034	CLRND 5	161.0	560001	NODAWAYCO	161.0	1	153	147.6	147.9	4.8%	S1399 to Humboldt	XS532861>532865>\$1
635034	CLRND 5	161.0	560001	NODAWAYCO	161.0	1	153	147.6	147.9	4.8%	S1399 to Humboldt	XS532796>514715>\$1

635034	CLRND 5	161.0	560001	NODAWAYCO	161.0	1	153	147.5	147.9	4.8%	S1399 to Humboldt	XS532872>532873>\$1
635034	CLRND 5	161.0	560001	NODAWAYCO	161.0	1	153	147.5	147.9	4.8%	S1399 to Humboldt	XS300120>300207>\$1
635034	CLRND 5	161.0	560001	NODAWAYCO	161.0	1	153	147.5	147.9	4.8%	S1399 to Humboldt	XS300108>300816>\$1
635034	CLRND 5	161.0	560001	NODAWAYCO	161.0	1	153	147.6	147.9	4.8%	S1399 to Humboldt	XS533036>533045>\$1
635034	CLRND 5	161.0	560001	NODAWAYCO	161.0	1	153	147.6	147.9	4.8%	S1399 to Humboldt	XS533361>533887>\$1
635034	CLRND 5	161.0	560001	NODAWAYCO	161.0	1	153	147.6	147.9	4.8%	S1399 to Humboldt	XS533308>533309>\$1
635034	CLRND 5	161.0	560001	NODAWAYCO	161.0	1	153	147.5	147.9	4.8%	S1399 to Humboldt	XS533001>533674>533086\$1
635034	CLRND 5	161.0	560001	NODAWAYCO	161.0	1	153	147.6	147.9	4.8%	S1399 to Humboldt	XS652509>652526>\$1
635034	CLRND 5	161.0	560001	NODAWAYCO	161.0	1	153	147.6	147.9	4.8%	S1399 to Humboldt	XS652523>652578>\$1
635034	CLRND 5	161.0	560001	NODAWAYCO	161.0	1	153	147.6	147.9	4.8%	S1399 to Humboldt	XS652503>620314>\$1
635034	CLRND 5	161.0	560001	NODAWAYCO	161.0	1	153	147.6	147.9	4.8%	S1399 to Humboldt	XS652607>659122>\$1
635034	CLRND 5	161.0	560001	NODAWAYCO	161.0	1	153	147.5	147.9	4.8%	S1399 to Humboldt	XS652514>659205>\$1
635034	CLRND 5	161.0	560001	NODAWAYCO	161.0	1	153	147.5	147.9	4.8%	S1399 to Humboldt	XS652509>652565>\$1
635034	CLRND 5	161.0	560001	NODAWAYCO	161.0	1	153	147.6	147.9	4.8%	S1399 to Humboldt	XS652513>659122>\$1
635034	CLRND 5	161.0	560001	NODAWAYCO	161.0	1	153	147.6	147.9	4.8%	S1399 to Humboldt	CB974-BUS
635034	CLRND 5	161.0	560001	NODAWAYCO	161.0	1	153	147.6	147.9	4.8%	S1399 to Humboldt	CB3451-59&T3
635034	CLRND 5	161.0	560001	NODAWAYCO	161.0	1	153	147.5	147.9	4.8%	S1399 to Humboldt	CB974-BUS969
635034	CLRND 5	161.0	560001	NODAWAYCO	161.0	1	153	147.6	147.9	4.8%	S1399 to Humboldt	CB974-BUS-EN
635034	CLRND 5	161.0	560001	NODAWAYCO	161.0	1	153	147.6	147.9	4.8%	S1399 to Humboldt	CB1231-21&27
635034	CLRND 5	161.0	560001	NODAWAYCO	161.0	1	153	147.6	147.9	4.8%	S1399 to Humboldt	XS542969>543057>\$1
635034	CLRND 5	161.0	560001	NODAWAYCO	161.0	1	153	147.6	147.9	4.8%	S1399 to Humboldt	XS543028>541230>\$1
635034	CLRND 5	161.0	560001	NODAWAYCO	161.0	1	153	147.5	147.9	4.8%	S1399 to Humboldt	XS533419>530618>\$1
635034	CLRND 5	161.0	560001	NODAWAYCO	161.0	1	153	147.6	147.9	4.8%	S1399 to Humboldt	XS541244>541250>\$1
635034	CLRND 5	161.0	560001	NODAWAYCO	161.0	1	153	147.5	147.9	4.8%	S1399 to Humboldt	XS541236>541244>\$1
635034	CLRND 5	161.0	560001	NODAWAYCO	161.0	1	153	147.5	147.9	4.8%	S1399 to Humboldt	XS541208>300070>\$1
635034	CLRND 5	161.0	560001	NODAWAYCO	161.0	1	153	147.5	147.9	4.8%	S1399 to Humboldt	XS543044>543056>\$1
635034	CLRND 5	161.0	560001	NODAWAYCO	161.0	1	153	147.6	147.9	4.8%	S1399 to Humboldt	XS541235>541250>\$1

635034	CLRNDA 5 161.0	560001	NODAWAYCO 161.0	1	153	147.6	147.9	4.8%	S1399 to Humboldt	XS631048>631049>\$1
635034	CLRNDA 5 161.0	560001	NODAWAYCO 161.0	1	153	147.6	147.9	4.8%	S1399 to Humboldt	XS631041>631124>\$1
635034	CLRNDA 5 161.0	560001	NODAWAYCO 161.0	1	153	147.6	147.9	4.8%	S1399 to Humboldt	XS631049>631103>\$1
635034	CLRNDA 5 161.0	560001	NODAWAYCO 161.0	1	153	147.6	147.9	4.8%	S1399 to Humboldt	XS613330>693755>\$1
635034	CLRNDA 5 161.0	560001	NODAWAYCO 161.0	1	153	147.6	147.9	4.8%	S1399 to Humboldt	XS631081>631082>\$1
635034	CLRNDA 5 161.0	560001	NODAWAYCO 161.0	1	153	147.6	147.9	4.8%	S1399 to Humboldt	XS631048>656201>\$1
635034	CLRNDA 5 161.0	560001	NODAWAYCO 161.0	1	153	147.6	147.9	4.8%	S1399 to Humboldt	XS631050>636200>\$1
635034	CLRNDA 5 161.0	560001	NODAWAYCO 161.0	1	153	147.7	147.9	3.8%	S1280 to Humboldt	XS631141>270864>\$1
635034	CLRNDA 5 161.0	560001	NODAWAYCO 161.0	1	153	147.6	147.9	3.8%	S1280 to Humboldt	XS631042>629046>\$1
635034	CLRNDA 5 161.0	560001	NODAWAYCO 161.0	1	153	147.6	147.9	3.8%	S1399 to Humboldt	XS635200>636010>\$1
635034	CLRNDA 5 161.0	560001	NODAWAYCO 161.0	1	153	147.6	147.9	3.8%	S1399 to Humboldt	XS636610>636615>\$1
635034	CLRNDA 5 161.0	560001	NODAWAYCO 161.0	1	153	147.6	147.9	3.8%	S1399 to Humboldt	XS300068>300207>\$1
635034	CLRNDA 5 161.0	560001	NODAWAYCO 161.0	1	153	147.6	147.9	3.8%	S1399 to Humboldt	XS652507>652606>\$1
635034	CLRNDA 5 161.0	560001	NODAWAYCO 161.0	1	153	147.6	147.9	3.8%	S1399 to Humboldt	XS631070>630009>\$1
635034	CLRNDA 5 161.0	560001	NODAWAYCO 161.0	1	153	147.6	147.9	3.8%	S1280 to Humboldt	XS631109>629071>\$1
635034	CLRNDA 5 161.0	560001	NODAWAYCO 161.0	1	153	147.6	147.9	3.8%	S1399 to Humboldt	XS631154>631151>\$1
635034	CLRNDA 5 161.0	560001	NODAWAYCO 161.0	1	153	147.6	147.9	3.8%	S1399 to Humboldt	XS635032>635033>\$1
635034	CLRNDA 5 161.0	560001	NODAWAYCO 161.0	1	153	147.6	147.9	3.8%	S1399 to Humboldt	XS631154>631150>\$1
635034	CLRNDA 5 161.0	560001	NODAWAYCO 161.0	1	153	147.6	147.9	3.8%	S1399 to Humboldt	XS636600>636605>\$1
635034	CLRNDA 5 161.0	560001	NODAWAYCO 161.0	1	153	147.6	147.9	3.8%	S1399 to Humboldt	XS647102>647974>\$1
635034	CLRNDA 5 161.0	560001	NODAWAYCO 161.0	1	153	147.6	147.9	3.8%	S1399 to Humboldt	XS647102>647970>\$1
635034	CLRNDA 5 161.0	560001	NODAWAYCO 161.0	1	153	147.6	147.9	3.8%	S1399 to Humboldt	XS533036>539675>\$1
635034	CLRNDA 5 161.0	560001	NODAWAYCO 161.0	1	153	147.6	147.9	3.8%	S1399 to Humboldt	ENRONTAP
635034	CLRNDA 5 161.0	560001	NODAWAYCO 161.0	1	153	147.6	147.9	3.8%	S1399 to Humboldt	XS543065>543069>\$1
635034	CLRNDA 5 161.0	560001	NODAWAYCO 161.0	1	153	147.6	147.9	3.8%	S1399 to Humboldt	XS543060>344558>\$1
635034	CLRNDA 5 161.0	560001	NODAWAYCO 161.0	1	153	147.6	147.9	3.8%	S1399 to Humboldt	XS631061>631140>\$1
635034	CLRNDA 5 161.0	560001	NODAWAYCO 161.0	1	153	147.7	147.9	3.8%	S975 (Humboldt) T4 161-69	BKR-HLD-3005

635034	CLRND 5 161.0	560001	NODAWAYCO 161.0	1	153	147.5	147.8	5.7%	S1399 to Humboldt	XS533332>640426>\$1
635034	CLRND 5 161.0	560001	NODAWAYCO 161.0	1	153	147.5	147.8	4.8%	S1399 to Humboldt	XS631115>631134>\$1
635034	CLRND 5 161.0	560001	NODAWAYCO 161.0	1	153	147.5	147.8	4.8%	S1399 to Humboldt	XS635700>635701>635706\$1
635034	CLRND 5 161.0	560001	NODAWAYCO 161.0	1	153	147.5	147.8	4.8%	S1399 to Humboldt	XS635700>635701>635707\$2
635034	CLRND 5 161.0	560001	NODAWAYCO 161.0	1	153	147.5	147.8	4.8%	S1399 to Humboldt	XS635605>635606>\$1
635034	CLRND 5 161.0	560001	NODAWAYCO 161.0	1	153	147.5	147.8	4.8%	S1399 to Humboldt	XS631113>635870>\$1
635034	CLRND 5 161.0	560001	NODAWAYCO 161.0	1	153	147.4	147.8	4.8%	S1399 to Humboldt	XS635601>635602>\$1
635034	CLRND 5 161.0	560001	NODAWAYCO 161.0	1	153	147.4	147.8	4.8%	S1399 to Humboldt	XS631113>630050>\$1
635034	CLRND 5 161.0	560001	NODAWAYCO 161.0	1	153	147.5	147.8	4.8%	S1399 to Humboldt	XS635651>635660>\$1
635034	CLRND 5 161.0	560001	NODAWAYCO 161.0	1	153	147.5	147.8	4.8%	S1399 to Humboldt	XS635632>635833>\$1
635034	CLRND 5 161.0	560001	NODAWAYCO 161.0	1	153	147.5	147.8	4.8%	S1399 to Humboldt	XS635665>635701>\$1
635034	CLRND 5 161.0	560001	NODAWAYCO 161.0	1	153	147.4	147.8	4.8%	S1399 to Humboldt	XS631096>631098>\$1
635034	CLRND 5 161.0	560001	NODAWAYCO 161.0	1	153	147.5	147.8	4.8%	S1399 to Humboldt	XS635300>635301>\$1
635034	CLRND 5 161.0	560001	NODAWAYCO 161.0	1	153	147.5	147.8	4.8%	S1399 to Humboldt	XS640065>640374>\$1
635034	CLRND 5 161.0	560001	NODAWAYCO 161.0	1	153	147.5	147.8	4.8%	S1399 to Humboldt	XS640093>640094>643026\$1
635034	CLRND 5 161.0	560001	NODAWAYCO 161.0	1	153	147.5	147.8	4.8%	S1399 to Humboldt	XS640089>640094>\$1
635034	CLRND 5 161.0	560001	NODAWAYCO 161.0	1	153	147.5	147.8	4.8%	S1399 to Humboldt	XS640107>640201>\$1
635034	CLRND 5 161.0	560001	NODAWAYCO 161.0	1	153	147.5	147.8	4.8%	S1399 to Humboldt	XS640082>640326>\$1
635034	CLRND 5 161.0	560001	NODAWAYCO 161.0	1	153	147.5	147.8	4.8%	S1399 to Humboldt	XS640131>640200>\$1
635034	CLRND 5 161.0	560001	NODAWAYCO 161.0	1	153	147.5	147.8	4.8%	S1399 to Humboldt	XS640136>640181>\$1
635034	CLRND 5 161.0	560001	NODAWAYCO 161.0	1	153	147.5	147.8	4.8%	S1399 to Humboldt	XS640136>640336>\$1
635034	CLRND 5 161.0	560001	NODAWAYCO 161.0	1	153	147.5	147.8	4.8%	S1399 to Humboldt	XS640050>640025>\$1
635034	CLRND 5 161.0	560001	NODAWAYCO 161.0	1	153	147.5	147.8	4.8%	S1399 to Humboldt	XS640109>640334>\$1
635034	CLRND 5 161.0	560001	NODAWAYCO 161.0	1	153	147.5	147.8	4.8%	S1399 to Humboldt	XS640171>640362>\$1
635034	CLRND 5 161.0	560001	NODAWAYCO 161.0	1	153	147.4	147.8	4.8%	S1399 to Humboldt	XS640305>640349>\$1
635034	CLRND 5 161.0	560001	NODAWAYCO 161.0	1	153	147.5	147.8	4.8%	S1399 to Humboldt	XS640234>647975>648275\$1
635034	CLRND 5 161.0	560001	NODAWAYCO 161.0	1	153	147.5	147.8	4.8%	S1399 to Humboldt	XS640226>640227>643082\$1

635034	CLRND 5	161.0	560001	NODAWAYCO	161.0	1	153	147.5	147.8	4.8%	S1399 to Humboldt	XS640226>640342>\$1
635034	CLRND 5	161.0	560001	NODAWAYCO	161.0	1	153	147.5	147.8	4.8%	S1399 to Humboldt	XS640374>652571>\$1
635034	CLRND 5	161.0	560001	NODAWAYCO	161.0	1	153	147.5	147.8	4.8%	S1399 to Humboldt	XS640272>640413>\$1
635034	CLRND 5	161.0	560001	NODAWAYCO	161.0	1	153	147.5	147.8	4.8%	S1399 to Humboldt	XS640255>640016>\$1
635034	CLRND 5	161.0	560001	NODAWAYCO	161.0	1	153	147.5	147.8	4.8%	S1399 to Humboldt	XS640287>640018>\$1
635034	CLRND 5	161.0	560001	NODAWAYCO	161.0	1	153	147.5	147.8	4.8%	S1399 to Humboldt	XS640242>640015>\$1
635034	CLRND 5	161.0	560001	NODAWAYCO	161.0	1	153	147.5	147.8	4.8%	S1399 to Humboldt	XS640240>640014>\$1
635034	CLRND 5	161.0	560001	NODAWAYCO	161.0	1	153	147.5	147.8	4.8%	S1399 to Humboldt	XS640253>640255>\$1
635034	CLRND 5	161.0	560001	NODAWAYCO	161.0	1	153	147.5	147.8	4.8%	S1399 to Humboldt	XS640183>640374>\$1
635034	CLRND 5	161.0	560001	NODAWAYCO	161.0	1	153	147.5	147.8	4.8%	S1399 to Humboldt	XS640338>640397>\$1
635034	CLRND 5	161.0	560001	NODAWAYCO	161.0	1	153	147.5	147.8	4.8%	S1399 to Humboldt	XS640183>640374>\$2
635034	CLRND 5	161.0	560001	NODAWAYCO	161.0	1	153	147.5	147.8	4.8%	S1399 to Humboldt	XS640192>640334>\$1
635034	CLRND 5	161.0	560001	NODAWAYCO	161.0	1	153	147.5	147.8	4.8%	S1399 to Humboldt	XS640362>647974>\$1
635034	CLRND 5	161.0	560001	NODAWAYCO	161.0	1	153	147.5	147.8	4.8%	S1399 to Humboldt	XS640349>652510>\$1
635034	CLRND 5	161.0	560001	NODAWAYCO	161.0	1	153	147.5	147.8	4.8%	S1399 to Humboldt	XS640201>640353>\$1
635034	CLRND 5	161.0	560001	NODAWAYCO	161.0	1	153	147.5	147.8	4.8%	S1399 to Humboldt	XS646233>646255>\$1
635034	CLRND 5	161.0	560001	NODAWAYCO	161.0	1	153	147.5	147.8	4.8%	S1399 to Humboldt	XS646232>646278>\$1
635034	CLRND 5	161.0	560001	NODAWAYCO	161.0	1	153	147.5	147.8	4.8%	S1399 to Humboldt	XS650269>650275>\$1
635034	CLRND 5	161.0	560001	NODAWAYCO	161.0	1	153	147.5	147.8	4.8%	S1399 to Humboldt	XS646233>646234>\$1
635034	CLRND 5	161.0	560001	NODAWAYCO	161.0	1	153	147.5	147.8	4.8%	S1399 to Humboldt	XS646221>647921>648221\$1
635034	CLRND 5	161.0	560001	NODAWAYCO	161.0	1	153	147.5	147.8	4.8%	S1399 to Humboldt	XS646217>646227>\$1
635034	CLRND 5	161.0	560001	NODAWAYCO	161.0	1	153	147.4	147.8	4.8%	S1399 to Humboldt	XS646221>646231>\$1
635034	CLRND 5	161.0	560001	NODAWAYCO	161.0	1	153	147.5	147.8	4.8%	S1399 to Humboldt	XS647014>647914>\$1
635034	CLRND 5	161.0	560001	NODAWAYCO	161.0	1	153	147.5	147.8	4.8%	S1399 to Humboldt	XS650114>650214>650314\$1
635034	CLRND 5	161.0	560001	NODAWAYCO	161.0	1	153	147.5	147.8	4.8%	S1399 to Humboldt	XS647402>647970>\$1
635034	CLRND 5	161.0	560001	NODAWAYCO	161.0	1	153	147.5	147.8	4.8%	S1399 to Humboldt	XS646259>646278>\$1
635034	CLRND 5	161.0	560001	NODAWAYCO	161.0	1	153	147.5	147.8	4.8%	S1399 to Humboldt	XS645451>646251>648351\$1

635034	CLRND 5 161.0	560001	NODAWAYCO 161.0	1	153	147.5	147.8	4.8%	S1399 to Humboldt	XS646249>646256>\$1
635034	CLRND 5 161.0	560001	NODAWAYCO 161.0	1	153	147.5	147.8	4.8%	S1399 to Humboldt	XS647402>647971>\$1
635034	CLRND 5 161.0	560001	NODAWAYCO 161.0	1	153	147.5	147.8	4.8%	S1399 to Humboldt	XS646253>646256>\$1
635034	CLRND 5 161.0	560001	NODAWAYCO 161.0	1	153	147.5	147.8	4.8%	S1399 to Humboldt	XS647401>647962>\$1
635034	CLRND 5 161.0	560001	NODAWAYCO 161.0	1	153	147.5	147.8	4.8%	S1399 to Humboldt	XS646250>646297>\$1
635034	CLRND 5 161.0	560001	NODAWAYCO 161.0	1	153	147.5	147.8	4.8%	S1399 to Humboldt	XS645451>646251>648251\$1
635034	CLRND 5 161.0	560001	NODAWAYCO 161.0	1	153	147.5	147.8	4.8%	S1399 to Humboldt	XS300071>300124>\$1
635034	CLRND 5 161.0	560001	NODAWAYCO 161.0	1	153	147.4	147.8	4.8%	S1399 to Humboldt	XS300087>300094>\$1
635034	CLRND 5 161.0	560001	NODAWAYCO 161.0	1	153	147.5	147.8	4.8%	S1399 to Humboldt	XS300090>300523>\$1
635034	CLRND 5 161.0	560001	NODAWAYCO 161.0	1	153	147.5	147.8	4.8%	S1399 to Humboldt	TWR-SCH-MN
635034	CLRND 5 161.0	560001	NODAWAYCO 161.0	1	153	147.5	147.8	4.8%	S1399 to Humboldt	TWR-SCH-NH
635034	CLRND 5 161.0	560001	NODAWAYCO 161.0	1	153	147.4	147.8	4.8%	S1399 to Humboldt	XS300086>300563>\$1
635034	CLRND 5 161.0	560001	NODAWAYCO 161.0	1	153	147.5	147.8	4.8%	S1399 to Humboldt	XS300066>300953>\$1
635034	CLRND 5 161.0	560001	NODAWAYCO 161.0	1	153	147.5	147.8	4.8%	S1399 to Humboldt	XS300044>345088>\$1
635034	CLRND 5 161.0	560001	NODAWAYCO 161.0	1	153	147.5	147.8	4.8%	S1399 to Humboldt	XS300065>344257>\$1
635034	CLRND 5 161.0	560001	NODAWAYCO 161.0	1	153	147.5	147.8	4.8%	S1399 to Humboldt	XS300098>548808>\$1
635034	CLRND 5 161.0	560001	NODAWAYCO 161.0	1	153	147.5	147.8	4.8%	S1399 to Humboldt	NCU GEN OFF
635034	CLRND 5 161.0	560001	NODAWAYCO 161.0	1	153	147.5	147.8	4.8%	S1399 to Humboldt	XS532770>532863>532809\$1
635034	CLRND 5 161.0	560001	NODAWAYCO 161.0	1	153	147.5	147.8	4.8%	S1399 to Humboldt	XS532874>533359>532817\$1
635034	CLRND 5 161.0	560001	NODAWAYCO 161.0	1	153	147.5	147.8	4.8%	S1399 to Humboldt	XS532772>533268>532816\$1
635034	CLRND 5 161.0	560001	NODAWAYCO 161.0	1	153	147.5	147.8	4.8%	S1399 to Humboldt	XS300499>300953>\$1
635034	CLRND 5 161.0	560001	NODAWAYCO 161.0	1	153	147.5	147.8	4.8%	S1399 to Humboldt	XS300499>343001>\$1
635034	CLRND 5 161.0	560001	NODAWAYCO 161.0	1	153	147.5	147.8	4.8%	S1399 to Humboldt	XS300816>505498>\$1
635034	CLRND 5 161.0	560001	NODAWAYCO 161.0	1	153	147.5	147.8	4.8%	S1399 to Humboldt	XS532871>533413>532892\$1
635034	CLRND 5 161.0	560001	NODAWAYCO 161.0	1	153	147.5	147.8	4.8%	S1399 to Humboldt	XS300555>300563>\$1
635034	CLRND 5 161.0	560001	NODAWAYCO 161.0	1	153	147.5	147.8	4.8%	S1399 to Humboldt	XS532772>533268>532811\$1
635034	CLRND 5 161.0	560001	NODAWAYCO 161.0	1	153	147.5	147.8	4.8%	S1399 to Humboldt	XS532936>532990>532956\$1

635034	CLRND 5	161.0	560001	NODAWAYCO	161.0	1	153	147.4	147.8	4.8%	S1399 to Humboldt	XS300274>512655>\$1
635034	CLRND 5	161.0	560001	NODAWAYCO	161.0	1	153	147.4	147.8	4.8%	S1399 to Humboldt	XS300274>512648>\$1
635034	CLRND 5	161.0	560001	NODAWAYCO	161.0	1	153	147.5	147.8	4.8%	S1399 to Humboldt	XS532921>532936>\$1
635034	CLRND 5	161.0	560001	NODAWAYCO	161.0	1	153	147.5	147.8	4.8%	S1399 to Humboldt	XS300103>361261>\$1
635034	CLRND 5	161.0	560001	NODAWAYCO	161.0	1	153	147.5	147.8	4.8%	S1399 to Humboldt	XS532920>532921>\$1
635034	CLRND 5	161.0	560001	NODAWAYCO	161.0	1	153	147.5	147.8	4.8%	S1399 to Humboldt	XS300110>300124>\$1
635034	CLRND 5	161.0	560001	NODAWAYCO	161.0	1	153	147.5	147.8	4.8%	S1399 to Humboldt	XS533220>533226>\$1
635034	CLRND 5	161.0	560001	NODAWAYCO	161.0	1	153	147.5	147.8	4.8%	S1399 to Humboldt	XS533302>533308>\$1
635034	CLRND 5	161.0	560001	NODAWAYCO	161.0	1	153	147.5	147.8	4.8%	S1399 to Humboldt	XS533015>533016>\$1
635034	CLRND 5	161.0	560001	NODAWAYCO	161.0	1	153	147.5	147.8	4.8%	S1399 to Humboldt	XS533170>533171>\$1
635034	CLRND 5	161.0	560001	NODAWAYCO	161.0	1	153	147.4	147.8	4.8%	S1399 to Humboldt	XS533367>533368>\$1
635034	CLRND 5	161.0	560001	NODAWAYCO	161.0	1	153	147.4	147.8	4.8%	S1399 to Humboldt	XS533359>533360>\$1
635034	CLRND 5	161.0	560001	NODAWAYCO	161.0	1	153	147.5	147.8	4.8%	S1399 to Humboldt	XS533212>533217>\$1
635034	CLRND 5	161.0	560001	NODAWAYCO	161.0	1	153	147.4	147.8	4.8%	S1399 to Humboldt	XS533309>533311>\$1
635034	CLRND 5	161.0	560001	NODAWAYCO	161.0	1	153	147.5	147.8	4.8%	S1399 to Humboldt	XS533249>533250>\$1
635034	CLRND 5	161.0	560001	NODAWAYCO	161.0	1	153	147.4	147.8	4.8%	S1399 to Humboldt	XS533311>533366>\$1
635034	CLRND 5	161.0	560001	NODAWAYCO	161.0	1	153	147.5	147.8	4.8%	S1399 to Humboldt	XS533151>533155>\$1
635034	CLRND 5	161.0	560001	NODAWAYCO	161.0	1	153	147.5	147.8	4.8%	S1399 to Humboldt	XS533001>533673>533087\$1
635034	CLRND 5	161.0	560001	NODAWAYCO	161.0	1	153	147.4	147.8	4.8%	S1399 to Humboldt	XS652506>659105>\$1
635034	CLRND 5	161.0	560001	NODAWAYCO	161.0	1	153	147.5	147.8	4.8%	S1399 to Humboldt	XS652482>659153>\$1
635034	CLRND 5	161.0	560001	NODAWAYCO	161.0	1	153	147.5	147.8	4.8%	S1399 to Humboldt	XS652507>652509>\$1
635034	CLRND 5	161.0	560001	NODAWAYCO	161.0	1	153	147.5	147.8	4.8%	S1399 to Humboldt	XS652466>652426>\$1
635034	CLRND 5	161.0	560001	NODAWAYCO	161.0	1	153	147.5	147.8	4.8%	S1399 to Humboldt	XS652507>652607>\$1
635034	CLRND 5	161.0	560001	NODAWAYCO	161.0	1	153	147.5	147.8	4.8%	S1399 to Humboldt	XS652509>652516>\$1
635034	CLRND 5	161.0	560001	NODAWAYCO	161.0	1	153	147.5	147.8	4.8%	S1399 to Humboldt	XS652570>659197>\$1
635034	CLRND 5	161.0	560001	NODAWAYCO	161.0	1	153	147.5	147.8	4.8%	S1399 to Humboldt	XS652565>652564>652304\$1
635034	CLRND 5	161.0	560001	NODAWAYCO	161.0	1	153	147.5	147.8	4.8%	S1399 to Humboldt	XS652565>652564>652305\$1

635034	CLRNDA 5	161.0	560001	NODAWAYCO	161.0	1	153	147.5	147.8	4.8%	S1399 to Humboldt	XS652523>652606>\$1
635034	CLRNDA 5	161.0	560001	NODAWAYCO	161.0	1	153	147.4	147.8	4.8%	S1399 to Humboldt	XS652503>652550>\$1
635034	CLRNDA 5	161.0	560001	NODAWAYCO	161.0	1	153	147.5	147.8	4.8%	S1399 to Humboldt	XS928113>928114>\$1
635034	CLRNDA 5	161.0	560001	NODAWAYCO	161.0	1	153	147.5	147.8	4.8%	S1399 to Humboldt	XS652507>652516>\$1
635034	CLRNDA 5	161.0	560001	NODAWAYCO	161.0	1	153	147.4	147.8	4.8%	S1399 to Humboldt	XS652513>652523>\$1
635034	CLRNDA 5	161.0	560001	NODAWAYCO	161.0	1	153	147.5	147.8	4.8%	S1399 to Humboldt	CB1298-51&05
635034	CLRNDA 5	161.0	560001	NODAWAYCO	161.0	1	153	147.5	147.8	4.8%	S1399 to Humboldt	LES7502
635034	CLRNDA 5	161.0	560001	NODAWAYCO	161.0	1	153	147.5	147.8	4.8%	S1399 to Humboldt	CB971-BUS
635034	CLRNDA 5	161.0	560001	NODAWAYCO	161.0	1	153	147.5	147.8	4.8%	S1399 to Humboldt	CB975-T4-965
635034	CLRNDA 5	161.0	560001	NODAWAYCO	161.0	1	153	147.5	147.8	4.8%	S1399 to Humboldt	CB1251-98&T3
635034	CLRNDA 5	161.0	560001	NODAWAYCO	161.0	1	153	147.5	147.8	4.8%	S1399 to Humboldt	CB1251-41&T4
635034	CLRNDA 5	161.0	560001	NODAWAYCO	161.0	1	153	147.5	147.8	4.8%	S1399 to Humboldt	CB921-BUS
635034	CLRNDA 5	161.0	560001	NODAWAYCO	161.0	1	153	147.5	147.8	4.8%	S1399 to Humboldt	ELKCITY_GEN
635034	CLRNDA 5	161.0	560001	NODAWAYCO	161.0	1	153	147.5	147.8	4.8%	S1399 to Humboldt	CB914A-46-T1
635034	CLRNDA 5	161.0	560001	NODAWAYCO	161.0	1	153	147.4	147.8	4.8%	S1399 to Humboldt	CB1259-BUS
635034	CLRNDA 5	161.0	560001	NODAWAYCO	161.0	1	153	147.5	147.8	4.8%	S1399 to Humboldt	CBHUM-80&T4
635034	CLRNDA 5	161.0	560001	NODAWAYCO	161.0	1	153	147.5	147.8	4.8%	S1399 to Humboldt	LES1401A
635034	CLRNDA 5	161.0	560001	NODAWAYCO	161.0	1	153	147.5	147.8	4.8%	S1399 to Humboldt	XS543026>541230>\$1
635034	CLRNDA 5	161.0	560001	NODAWAYCO	161.0	1	153	147.5	147.8	4.8%	S1399 to Humboldt	XS541217>300071>\$1
635034	CLRNDA 5	161.0	560001	NODAWAYCO	161.0	1	153	147.5	147.8	4.8%	S1399 to Humboldt	XS543019>541230>\$1
635034	CLRNDA 5	161.0	560001	NODAWAYCO	161.0	1	153	147.5	147.8	4.8%	S1399 to Humboldt	XS542986>542990>\$1
635034	CLRNDA 5	161.0	560001	NODAWAYCO	161.0	1	153	147.4	147.8	4.8%	S1399 to Humboldt	XS533415>533506>533444\$1
635034	CLRNDA 5	161.0	560001	NODAWAYCO	161.0	1	153	147.5	147.8	4.8%	S1399 to Humboldt	XS533414>533505>533453\$1
635034	CLRNDA 5	161.0	560001	NODAWAYCO	161.0	1	153	147.4	147.8	4.8%	S1399 to Humboldt	XS541209>541217>\$1
635034	CLRNDA 5	161.0	560001	NODAWAYCO	161.0	1	153	147.4	147.8	4.8%	S1399 to Humboldt	XS542997>543010>\$1
635034	CLRNDA 5	161.0	560001	NODAWAYCO	161.0	1	153	147.5	147.8	4.8%	S1399 to Humboldt	XS533435>533527>533446\$1
635034	CLRNDA 5	161.0	560001	NODAWAYCO	161.0	1	153	147.5	147.8	4.8%	S1399 to Humboldt	XS543006>543009>\$1

635034	CLRNDA 5	161.0	560001	NODAWAYCO	161.0	1	153	147.5	147.8	4.8%	S1399 to Humboldt	XS543007>543010>\$1
635034	CLRNDA 5	161.0	560001	NODAWAYCO	161.0	1	153	147.5	147.8	4.8%	S1399 to Humboldt	XS542966>543054>\$1
635034	CLRNDA 5	161.0	560001	NODAWAYCO	161.0	1	153	147.4	147.8	4.8%	S1399 to Humboldt	XS542966>543077>\$1
635034	CLRNDA 5	161.0	560001	NODAWAYCO	161.0	1	153	147.5	147.8	4.8%	S1399 to Humboldt	XS541226>541227>\$1
635034	CLRNDA 5	161.0	560001	NODAWAYCO	161.0	1	153	147.4	147.8	4.8%	S1399 to Humboldt	XS533413>533419>\$1
635034	CLRNDA 5	161.0	560001	NODAWAYCO	161.0	1	153	147.5	147.8	4.8%	S1399 to Humboldt	XS541228>541234>\$1
635034	CLRNDA 5	161.0	560001	NODAWAYCO	161.0	1	153	147.5	147.8	4.8%	S1399 to Humboldt	XS541204>541349>\$1
635034	CLRNDA 5	161.0	560001	NODAWAYCO	161.0	1	153	147.5	147.8	4.8%	S1399 to Humboldt	XS541205>541235>\$1
635034	CLRNDA 5	161.0	560001	NODAWAYCO	161.0	1	153	147.5	147.8	4.8%	S1399 to Humboldt	XS541232>541236>\$1
635034	CLRNDA 5	161.0	560001	NODAWAYCO	161.0	1	153	147.5	147.8	4.8%	S1399 to Humboldt	XS541225>541239>\$1
635034	CLRNDA 5	161.0	560001	NODAWAYCO	161.0	1	153	147.5	147.8	4.8%	S1399 to Humboldt	XS543051>543075>\$1
635034	CLRNDA 5	161.0	560001	NODAWAYCO	161.0	1	153	147.5	147.8	4.8%	S1399 to Humboldt	XS541205>541226>\$1
635034	CLRNDA 5	161.0	560001	NODAWAYCO	161.0	1	153	147.5	147.8	4.8%	S1399 to Humboldt	XS543072>543073>\$1
635034	CLRNDA 5	161.0	560001	NODAWAYCO	161.0	1	153	147.5	147.8	4.8%	S1399 to Humboldt	XS543067>543068>\$1
635034	CLRNDA 5	161.0	560001	NODAWAYCO	161.0	1	153	147.4	147.8	4.8%	S1399 to Humboldt	XS631062>631063>\$1
635034	CLRNDA 5	161.0	560001	NODAWAYCO	161.0	1	153	147.5	147.8	4.8%	S1399 to Humboldt	XS631063>631141>\$1
635034	CLRNDA 5	161.0	560001	NODAWAYCO	161.0	1	153	147.5	147.8	4.8%	S1399 to Humboldt	XS631034>631092>\$1
635034	CLRNDA 5	161.0	560001	NODAWAYCO	161.0	1	153	147.5	147.8	4.8%	S1399 to Humboldt	XS543064>543072>\$1
635034	CLRNDA 5	161.0	560001	NODAWAYCO	161.0	1	153	147.5	147.8	4.8%	S1399 to Humboldt	XS631095>631096>\$1
635034	CLRNDA 5	161.0	560001	NODAWAYCO	161.0	1	153	147.5	147.8	4.8%	S1399 to Humboldt	XS543074>543076>\$1
635034	CLRNDA 5	161.0	560001	NODAWAYCO	161.0	1	153	147.5	147.8	4.8%	S1399 to Humboldt	XS631051>636210>\$1
635034	CLRNDA 5	161.0	560001	NODAWAYCO	161.0	1	153	147.5	147.8	4.8%	S1399 to Humboldt	XS631034>631093>\$1
635034	CLRNDA 5	161.0	560001	NODAWAYCO	161.0	1	153	147.4	147.8	4.8%	S1399 to Humboldt	XS631051>631139>\$2
635034	CLRNDA 5	161.0	560001	NODAWAYCO	161.0	1	153	147.5	147.8	4.8%	S1399 to Humboldt	XS631035>631124>\$1
635034	CLRNDA 5	161.0	560001	NODAWAYCO	161.0	1	153	147.5	147.8	4.8%	S1399 to Humboldt	XS631035>629147>\$1
635034	CLRNDA 5	161.0	560001	NODAWAYCO	161.0	1	153	147.5	147.8	4.8%	S1399 to Humboldt	XS631093>636400>\$1
635034	CLRNDA 5	161.0	560001	NODAWAYCO	161.0	1	153	147.5	147.8	4.8%	S1399 to Humboldt	XS543057>543068>\$1

635034	CLRNDA 5 161.0	560001	NODAWAYCO 161.0	1	153	147.5	147.8	4.8%	S1399 to Humboldt	XS543057>543058>\$1
635034	CLRNDA 5 161.0	560001	NODAWAYCO 161.0	1	153	147.5	147.8	4.8%	S1399 to Humboldt	XS543067>543069>\$1
635034	CLRNDA 5 161.0	560001	NODAWAYCO 161.0	1	153	147.5	147.8	4.8%	S1399 to Humboldt	XS631066>631068>\$1
635034	CLRNDA 5 161.0	560001	NODAWAYCO 161.0	1	153	147.5	147.8	4.8%	S1399 to Humboldt	XS631050>631139>\$1
635034	CLRNDA 5 161.0	560001	NODAWAYCO 161.0	1	153	147.5	147.8	4.8%	S1399 to Humboldt	XS631067>631068>\$1
635034	CLRNDA 5 161.0	560001	NODAWAYCO 161.0	1	153	147.5	147.8	4.8%	S1399 to Humboldt	XS631074>656283>\$1
635034	CLRNDA 5 161.0	560001	NODAWAYCO 161.0	1	153	147.5	147.8	4.8%	S975 (Humboldt) T4 161-69	XS640234>646399>\$1
635034	CLRNDA 5 161.0	560001	NODAWAYCO 161.0	1	153	147.5	147.8	4.8%	S975 (Humboldt) T4 161-69	BKR-HMB-1604
635034	CLRNDA 5 161.0	560001	NODAWAYCO 161.0	1	153	147.5	147.8	3.8%	S1280 to Humboldt	XS631140>631141>\$1
635034	CLRNDA 5 161.0	560001	NODAWAYCO 161.0	1	153	147.5	147.8	3.8%	S1280 to Humboldt	XS640119>640028>\$1
635034	CLRNDA 5 161.0	560001	NODAWAYCO 161.0	1	153	147.5	147.8	3.8%	S1280 to Humboldt	XS645456>646206>648256\$1
635034	CLRNDA 5 161.0	560001	NODAWAYCO 161.0	1	153	147.5	147.8	3.8%	S1280 to Humboldt	XS645458>650189>\$1
635034	CLRNDA 5 161.0	560001	NODAWAYCO 161.0	1	153	147.6	147.8	3.8%	S1280 to Humboldt	XS300044>300049>\$1
635034	CLRNDA 5 161.0	560001	NODAWAYCO 161.0	1	153	147.5	147.8	3.8%	S1280 to Humboldt	SARPY4_GEN
635034	CLRNDA 5 161.0	560001	NODAWAYCO 161.0	1	153	147.5	147.8	3.8%	S1280 to Humboldt	SARPY5_GEN
635034	CLRNDA 5 161.0	560001	NODAWAYCO 161.0	1	153	147.6	147.8	3.8%	S1280 to Humboldt	CB3456-59&T4
635034	CLRNDA 5 161.0	560001	NODAWAYCO 161.0	1	153	147.5	147.8	3.8%	S1399 to Humboldt	XS635320>656283>\$1
635034	CLRNDA 5 161.0	560001	NODAWAYCO 161.0	1	153	147.5	147.8	3.8%	S1399 to Humboldt	XS635003>646211>\$1
635034	CLRNDA 5 161.0	560001	NODAWAYCO 161.0	1	153	147.4	147.8	3.8%	S1399 to Humboldt	XS635606>635607>\$1
635034	CLRNDA 5 161.0	560001	NODAWAYCO 161.0	1	153	147.4	147.8	3.8%	S1399 to Humboldt	XS631103>629084>\$1
635034	CLRNDA 5 161.0	560001	NODAWAYCO 161.0	1	153	147.4	147.8	3.8%	S1399 to Humboldt	XS635660>635661>\$1
635034	CLRNDA 5 161.0	560001	NODAWAYCO 161.0	1	153	147.4	147.8	3.8%	S1399 to Humboldt	XS635680>635700>\$1
635034	CLRNDA 5 161.0	560001	NODAWAYCO 161.0	1	153	147.5	147.8	3.8%	S1399 to Humboldt	XS635635>635640>\$1
635034	CLRNDA 5 161.0	560001	NODAWAYCO 161.0	1	153	147.4	147.8	3.8%	S1399 to Humboldt	XS640136>640007>\$1
635034	CLRNDA 5 161.0	560001	NODAWAYCO 161.0	1	153	147.4	147.8	3.8%	S1399 to Humboldt	XS640136>640008>\$1
635034	CLRNDA 5 161.0	560001	NODAWAYCO 161.0	1	153	147.4	147.8	3.8%	S1399 to Humboldt	XS640136>640006>\$1
635034	CLRNDA 5 161.0	560001	NODAWAYCO 161.0	1	153	147.5	147.8	3.8%	S1399 to Humboldt	XS640084>640419>\$1

635034	CLRND 5 161.0	560001	NODAWAYCO 161.0	1	153	147.4	147.8	3.8%	S1399 to Humboldt	XS640065>640066>640067\$1
635034	CLRND 5 161.0	560001	NODAWAYCO 161.0	1	153	147.5	147.8	3.8%	S1399 to Humboldt	XS640098>640267>\$1
635034	CLRND 5 161.0	560001	NODAWAYCO 161.0	1	153	147.5	147.8	3.8%	S1399 to Humboldt	XS640444>640433>\$1
635034	CLRND 5 161.0	560001	NODAWAYCO 161.0	1	153	147.5	147.8	3.8%	S1399 to Humboldt	XS650238>650242>\$1
635034	CLRND 5 161.0	560001	NODAWAYCO 161.0	1	153	147.5	147.8	3.8%	S1399 to Humboldt	XS646251>646297>\$1
635034	CLRND 5 161.0	560001	NODAWAYCO 161.0	1	153	147.4	147.8	3.8%	S1399 to Humboldt	XS646255>646259>\$1
635034	CLRND 5 161.0	560001	NODAWAYCO 161.0	1	153	147.5	147.8	3.8%	S1399 to Humboldt	XS646214>647014>648214\$1
635034	CLRND 5 161.0	560001	NODAWAYCO 161.0	1	153	147.5	147.8	3.8%	S1399 to Humboldt	XS300058>344697>\$1
635034	CLRND 5 161.0	560001	NODAWAYCO 161.0	1	153	147.5	147.8	3.8%	S1399 to Humboldt	XS300099>300523>\$1
635034	CLRND 5 161.0	560001	NODAWAYCO 161.0	1	153	147.5	147.8	3.8%	S1399 to Humboldt	XS300101>505498>\$1
635034	CLRND 5 161.0	560001	NODAWAYCO 161.0	1	153	147.5	147.8	3.8%	S1399 to Humboldt	MC1214-14-46
635034	CLRND 5 161.0	560001	NODAWAYCO 161.0	1	153	147.4	147.8	3.8%	S1399 to Humboldt	XS532797>533653>\$1
635034	CLRND 5 161.0	560001	NODAWAYCO 161.0	1	153	147.4	147.8	3.8%	S1399 to Humboldt	XS533164>533165>\$1
635034	CLRND 5 161.0	560001	NODAWAYCO 161.0	1	153	147.5	147.8	3.8%	S1399 to Humboldt	XS533342>533344>\$1
635034	CLRND 5 161.0	560001	NODAWAYCO 161.0	1	153	147.5	147.8	3.8%	S1399 to Humboldt	XS533369>533380>\$1
635034	CLRND 5 161.0	560001	NODAWAYCO 161.0	1	153	147.4	147.8	3.8%	S1399 to Humboldt	XS659132>659187>\$1
635034	CLRND 5 161.0	560001	NODAWAYCO 161.0	1	153	147.4	147.8	3.8%	S1399 to Humboldt	XS652512>659287>\$1
635034	CLRND 5 161.0	560001	NODAWAYCO 161.0	1	153	147.5	147.8	3.8%	S1399 to Humboldt	XS652529>659160>\$1
635034	CLRND 5 161.0	560001	NODAWAYCO 161.0	1	153	147.4	147.8	3.8%	S1399 to Humboldt	LES8506
635034	CLRND 5 161.0	560001	NODAWAYCO 161.0	1	153	147.5	147.8	3.8%	S1399 to Humboldt	LN-CLATONIA
635034	CLRND 5 161.0	560001	NODAWAYCO 161.0	1	153	147.5	147.8	3.8%	S1399 to Humboldt	LES3804B
635034	CLRND 5 161.0	560001	NODAWAYCO 161.0	1	153	147.4	147.8	3.8%	S1399 to Humboldt	XS542978>543048>\$1
635034	CLRND 5 161.0	560001	NODAWAYCO 161.0	1	153	147.4	147.8	3.8%	S1399 to Humboldt	XS543016>543029>\$1
635034	CLRND 5 161.0	560001	NODAWAYCO 161.0	1	153	147.5	147.8	3.8%	S1399 to Humboldt	XS542986>542996>\$1
635034	CLRND 5 161.0	560001	NODAWAYCO 161.0	1	153	147.4	147.8	3.8%	S1399 to Humboldt	XS541229>541232>\$1
635034	CLRND 5 161.0	560001	NODAWAYCO 161.0	1	153	147.5	147.8	3.8%	S1399 to Humboldt	XS541255>541256>\$1
635034	CLRND 5 161.0	560001	NODAWAYCO 161.0	1	153	147.4	147.8	3.8%	S1399 to Humboldt	XS541212>541213>\$1

635034	CLRNDA 5	161.0	560001	NODAWAYCO	161.0	1	153	147.4	147.8	3.8%	S1399 to Humboldt	XS541212>541221>\$1
635034	CLRNDA 5	161.0	560001	NODAWAYCO	161.0	1	153	147.4	147.8	3.8%	S1399 to Humboldt	XS541248>300098>\$1
635034	CLRNDA 5	161.0	560001	NODAWAYCO	161.0	1	153	147.4	147.8	3.8%	S1399 to Humboldt	XS631075>344290>\$1
635034	CLRNDA 5	161.0	560001	NODAWAYCO	161.0	1	153	147.4	147.8	3.8%	S1399 to Humboldt	XS543055>543077>\$1
635034	CLRNDA 5	161.0	560001	NODAWAYCO	161.0	1	153	147.4	147.8	3.8%	S1399 to Humboldt	XS631084>344290>\$1
635034	CLRNDA 5	161.0	560001	NODAWAYCO	161.0	1	153	147.4	147.7	4.8%	S1399 to Humboldt	XS631114>630052>\$1
635034	CLRNDA 5	161.0	560001	NODAWAYCO	161.0	1	153	147.3	147.7	4.8%	S1399 to Humboldt	XS631116>630047>\$1
635034	CLRNDA 5	161.0	560001	NODAWAYCO	161.0	1	153	147.4	147.7	4.8%	S1399 to Humboldt	XS635701>635703>\$1
635034	CLRNDA 5	161.0	560001	NODAWAYCO	161.0	1	153	147.3	147.7	4.8%	S1399 to Humboldt	XS635039>635040>\$2
635034	CLRNDA 5	161.0	560001	NODAWAYCO	161.0	1	153	147.4	147.7	4.8%	S1399 to Humboldt	XS635602>635603>\$1
635034	CLRNDA 5	161.0	560001	NODAWAYCO	161.0	1	153	147.3	147.7	4.8%	S1399 to Humboldt	XS635041>635046>\$1
635034	CLRNDA 5	161.0	560001	NODAWAYCO	161.0	1	153	147.3	147.7	4.8%	S1399 to Humboldt	XS635705>635710>\$1
635034	CLRNDA 5	161.0	560001	NODAWAYCO	161.0	1	153	147.4	147.7	4.8%	S1399 to Humboldt	XS631115>631116>\$1
635034	CLRNDA 5	161.0	560001	NODAWAYCO	161.0	1	153	147.4	147.7	4.8%	S1399 to Humboldt	XS631114>633241>\$1
635034	CLRNDA 5	161.0	560001	NODAWAYCO	161.0	1	153	147.4	147.7	4.8%	S1399 to Humboldt	XS631107>630046>\$1
635034	CLRNDA 5	161.0	560001	NODAWAYCO	161.0	1	153	147.3	147.7	4.8%	S1399 to Humboldt	XS635701>635705>\$1
635034	CLRNDA 5	161.0	560001	NODAWAYCO	161.0	1	153	147.4	147.7	4.8%	S1399 to Humboldt	XS635681>635703>\$1
635034	CLRNDA 5	161.0	560001	NODAWAYCO	161.0	1	153	147.4	147.7	4.8%	S1399 to Humboldt	XS631123>631127>\$1
635034	CLRNDA 5	161.0	560001	NODAWAYCO	161.0	1	153	147.3	147.7	4.8%	S1399 to Humboldt	XS631122>681537>\$1
635034	CLRNDA 5	161.0	560001	NODAWAYCO	161.0	1	153	147.4	147.7	4.8%	S1399 to Humboldt	XS635601>635605>\$1
635034	CLRNDA 5	161.0	560001	NODAWAYCO	161.0	1	153	147.3	147.7	4.8%	S1399 to Humboldt	XS635605>635614>\$1
635034	CLRNDA 5	161.0	560001	NODAWAYCO	161.0	1	153	147.3	147.7	4.8%	S1399 to Humboldt	XS636001>656369>\$1
635034	CLRNDA 5	161.0	560001	NODAWAYCO	161.0	1	153	147.4	147.7	4.8%	S1399 to Humboldt	XS636001>636025>\$1
635034	CLRNDA 5	161.0	560001	NODAWAYCO	161.0	1	153	147.4	147.7	4.8%	S1399 to Humboldt	XS631109>630038>\$1
635034	CLRNDA 5	161.0	560001	NODAWAYCO	161.0	1	153	147.4	147.7	4.8%	S1399 to Humboldt	XS631109>630037>\$1
635034	CLRNDA 5	161.0	560001	NODAWAYCO	161.0	1	153	147.3	147.7	4.8%	S1399 to Humboldt	XS635350>635360>\$1
635034	CLRNDA 5	161.0	560001	NODAWAYCO	161.0	1	153	147.4	147.7	4.8%	S1399 to Humboldt	XS631107>631119>\$1

635034	CLRNDA 5	161.0	560001	NODAWAYCO	161.0	1	153	147.4	147.7	4.8%	S1399 to Humboldt	XS635201>640377>\$1
635034	CLRNDA 5	161.0	560001	NODAWAYCO	161.0	1	153	147.4	147.7	4.8%	S1399 to Humboldt	XS635200>635201>635205\$1
635034	CLRNDA 5	161.0	560001	NODAWAYCO	161.0	1	153	147.4	147.7	4.8%	S1399 to Humboldt	XS635870>635871>\$1
635034	CLRNDA 5	161.0	560001	NODAWAYCO	161.0	1	153	147.4	147.7	4.8%	S1399 to Humboldt	XS631113>631117>\$1
635034	CLRNDA 5	161.0	560001	NODAWAYCO	161.0	1	153	147.4	147.7	4.8%	S1399 to Humboldt	XS635870>635871>\$2
635034	CLRNDA 5	161.0	560001	NODAWAYCO	161.0	1	153	147.4	147.7	4.8%	S1399 to Humboldt	XS635200>635201>\$2
635034	CLRNDA 5	161.0	560001	NODAWAYCO	161.0	1	153	147.4	147.7	4.8%	S1399 to Humboldt	XS631111>630036>\$1
635034	CLRNDA 5	161.0	560001	NODAWAYCO	161.0	1	153	147.4	147.7	4.8%	S1399 to Humboldt	XS636001>636020>\$1
635034	CLRNDA 5	161.0	560001	NODAWAYCO	161.0	1	153	147.3	147.7	4.8%	S1399 to Humboldt	XS635600>636010>\$1
635034	CLRNDA 5	161.0	560001	NODAWAYCO	161.0	1	153	147.4	147.7	4.8%	S1399 to Humboldt	XS631128>631156>\$1
635034	CLRNDA 5	161.0	560001	NODAWAYCO	161.0	1	153	147.4	147.7	4.8%	S1399 to Humboldt	XS631166>636230>\$1
635034	CLRNDA 5	161.0	560001	NODAWAYCO	161.0	1	153	147.3	147.7	4.8%	S1399 to Humboldt	XS635651>635670>\$1
635034	CLRNDA 5	161.0	560001	NODAWAYCO	161.0	1	153	147.4	147.7	4.8%	S1399 to Humboldt	XS631163>681529>\$1
635034	CLRNDA 5	161.0	560001	NODAWAYCO	161.0	1	153	147.3	147.7	4.8%	S1399 to Humboldt	XS635651>635670>\$2
635034	CLRNDA 5	161.0	560001	NODAWAYCO	161.0	1	153	147.4	147.7	4.8%	S1399 to Humboldt	XS631156>631175>\$1
635034	CLRNDA 5	161.0	560001	NODAWAYCO	161.0	1	153	147.4	147.7	4.8%	S1399 to Humboldt	XS631166>631170>\$1
635034	CLRNDA 5	161.0	560001	NODAWAYCO	161.0	1	153	147.4	147.7	4.8%	S1399 to Humboldt	XS631183>656570>\$1
635034	CLRNDA 5	161.0	560001	NODAWAYCO	161.0	1	153	147.4	147.7	4.8%	S1399 to Humboldt	XS631181>631182>\$1
635034	CLRNDA 5	161.0	560001	NODAWAYCO	161.0	1	153	147.4	147.7	4.8%	S1399 to Humboldt	XS631175>630710>\$1
635034	CLRNDA 5	161.0	560001	NODAWAYCO	161.0	1	153	147.4	147.7	4.8%	S1399 to Humboldt	XS631174>680542>\$1
635034	CLRNDA 5	161.0	560001	NODAWAYCO	161.0	1	153	147.3	147.7	4.8%	S1399 to Humboldt	XS635670>635672>\$1
635034	CLRNDA 5	161.0	560001	NODAWAYCO	161.0	1	153	147.4	147.7	4.8%	S1399 to Humboldt	XS635670>635671>\$1
635034	CLRNDA 5	161.0	560001	NODAWAYCO	161.0	1	153	147.4	147.7	4.8%	S1399 to Humboldt	XS635670>635671>\$2
635034	CLRNDA 5	161.0	560001	NODAWAYCO	161.0	1	153	147.3	147.7	4.8%	S1399 to Humboldt	XS635672>635673>\$1
635034	CLRNDA 5	161.0	560001	NODAWAYCO	161.0	1	153	147.3	147.7	4.8%	S1399 to Humboldt	XS635610>635616>\$1
635034	CLRNDA 5	161.0	560001	NODAWAYCO	161.0	1	153	147.4	147.7	4.8%	S1399 to Humboldt	XS635673>635681>\$1
635034	CLRNDA 5	161.0	560001	NODAWAYCO	161.0	1	153	147.4	147.7	4.8%	S1399 to Humboldt	XS635603>635604>\$1

635034	CLRND 5	161.0	560001	NODAWAYCO	161.0	1	153	147.4	147.7	4.8%	S1399 to Humboldt	XS635661>635662>\$1
635034	CLRND 5	161.0	560001	NODAWAYCO	161.0	1	153	147.4	147.7	4.8%	S1399 to Humboldt	XS635662>635663>\$1
635034	CLRND 5	161.0	560001	NODAWAYCO	161.0	1	153	147.4	147.7	4.8%	S1399 to Humboldt	XS635662>635663>\$2
635034	CLRND 5	161.0	560001	NODAWAYCO	161.0	1	153	147.4	147.7	4.8%	S1399 to Humboldt	XS635614>635701>\$1
635034	CLRND 5	161.0	560001	NODAWAYCO	161.0	1	153	147.3	147.7	4.8%	S1399 to Humboldt	XS631139>631144>\$1
635034	CLRND 5	161.0	560001	NODAWAYCO	161.0	1	153	147.4	147.7	4.8%	S1399 to Humboldt	XS635662>635664>\$1
635034	CLRND 5	161.0	560001	NODAWAYCO	161.0	1	153	147.4	147.7	4.8%	S1399 to Humboldt	XS635614>635615>\$1
635034	CLRND 5	161.0	560001	NODAWAYCO	161.0	1	153	147.4	147.7	4.8%	S1399 to Humboldt	XS635664>635665>\$1
635034	CLRND 5	161.0	560001	NODAWAYCO	161.0	1	153	147.4	147.7	4.8%	S1399 to Humboldt	XS635223>635226>\$1
635034	CLRND 5	161.0	560001	NODAWAYCO	161.0	1	153	147.4	147.7	4.8%	S1399 to Humboldt	XS631096>630018>\$2
635034	CLRND 5	161.0	560001	NODAWAYCO	161.0	1	153	147.4	147.7	4.8%	S1399 to Humboldt	XS631102>630023>\$2
635034	CLRND 5	161.0	560001	NODAWAYCO	161.0	1	153	147.4	147.7	4.8%	S1399 to Humboldt	XS635221>635222>\$1
635034	CLRND 5	161.0	560001	NODAWAYCO	161.0	1	153	147.4	147.7	4.8%	S1399 to Humboldt	XS631106>300439>\$2
635034	CLRND 5	161.0	560001	NODAWAYCO	161.0	1	153	147.4	147.7	4.8%	S1399 to Humboldt	XS635223>635260>\$1
635034	CLRND 5	161.0	560001	NODAWAYCO	161.0	1	153	147.4	147.7	4.8%	S1399 to Humboldt	XS631103>656423>\$1
635034	CLRND 5	161.0	560001	NODAWAYCO	161.0	1	153	147.4	147.7	4.8%	S1399 to Humboldt	XS636200>636201>\$1
635034	CLRND 5	161.0	560001	NODAWAYCO	161.0	1	153	147.4	147.7	4.8%	S1399 to Humboldt	XS631096>630018>\$1
635034	CLRND 5	161.0	560001	NODAWAYCO	161.0	1	153	147.4	147.7	4.8%	S1399 to Humboldt	XS631104>631116>\$1
635034	CLRND 5	161.0	560001	NODAWAYCO	161.0	1	153	147.4	147.7	4.8%	S1399 to Humboldt	XS636025>636026>\$1
635034	CLRND 5	161.0	560001	NODAWAYCO	161.0	1	153	147.4	147.7	4.8%	S1399 to Humboldt	XS631106>631108>\$1
635034	CLRND 5	161.0	560001	NODAWAYCO	161.0	1	153	147.3	147.7	4.8%	S1399 to Humboldt	XS635221>635226>\$1
635034	CLRND 5	161.0	560001	NODAWAYCO	161.0	1	153	147.4	147.7	4.8%	S1399 to Humboldt	XS636200>636225>\$1
635034	CLRND 5	161.0	560001	NODAWAYCO	161.0	1	153	147.4	147.7	4.8%	S1399 to Humboldt	XS635320>635321>\$2
635034	CLRND 5	161.0	560001	NODAWAYCO	161.0	1	153	147.4	147.7	4.8%	S1399 to Humboldt	XS635280>635281>\$1
635034	CLRND 5	161.0	560001	NODAWAYCO	161.0	1	153	147.3	147.7	4.8%	S1399 to Humboldt	XS635220>635221>\$1
635034	CLRND 5	161.0	560001	NODAWAYCO	161.0	1	153	147.3	147.7	4.8%	S1399 to Humboldt	XS631104>630030>\$1
635034	CLRND 5	161.0	560001	NODAWAYCO	161.0	1	153	147.4	147.7	4.8%	S1399 to Humboldt	XS631104>631134>\$1

635034	CLRNDA 5 161.0	560001	NODAWAYCO 161.0	1	153	147.4	147.7	4.8%	S1399 to Humboldt	XS636050>636051>\$1
635034	CLRNDA 5 161.0	560001	NODAWAYCO 161.0	1	153	147.4	147.7	4.8%	S1399 to Humboldt	XS635340>635341>\$1
635034	CLRNDA 5 161.0	560001	NODAWAYCO 161.0	1	153	147.4	147.7	4.8%	S1399 to Humboldt	XS635261>635262>\$1
635034	CLRNDA 5 161.0	560001	NODAWAYCO 161.0	1	153	147.4	147.7	4.8%	S1399 to Humboldt	XS631102>630023>\$1
635034	CLRNDA 5 161.0	560001	NODAWAYCO 161.0	1	153	147.3	147.7	4.8%	S1399 to Humboldt	XS635280>635340>\$1
635034	CLRNDA 5 161.0	560001	NODAWAYCO 161.0	1	153	147.4	147.7	4.8%	S1399 to Humboldt	XS631106>300439>\$1
635034	CLRNDA 5 161.0	560001	NODAWAYCO 161.0	1	153	147.4	147.7	4.8%	S1399 to Humboldt	XS635223>652566>\$1
635034	CLRNDA 5 161.0	560001	NODAWAYCO 161.0	1	153	147.4	147.7	4.8%	S1399 to Humboldt	XS635223>635224>\$1
635034	CLRNDA 5 161.0	560001	NODAWAYCO 161.0	1	153	147.4	147.7	4.8%	S1399 to Humboldt	XS631098>631099>\$1
635034	CLRNDA 5 161.0	560001	NODAWAYCO 161.0	1	153	147.4	147.7	4.8%	S1399 to Humboldt	XS631102>631183>\$1
635034	CLRNDA 5 161.0	560001	NODAWAYCO 161.0	1	153	147.4	147.7	4.8%	S1399 to Humboldt	XS631095>631097>\$1
635034	CLRNDA 5 161.0	560001	NODAWAYCO 161.0	1	153	147.4	147.7	4.8%	S1399 to Humboldt	XS635320>635321>\$1
635034	CLRNDA 5 161.0	560001	NODAWAYCO 161.0	1	153	147.4	147.7	4.8%	S1399 to Humboldt	XS635260>635261>\$1
635034	CLRNDA 5 161.0	560001	NODAWAYCO 161.0	1	153	147.4	147.7	4.8%	S1399 to Humboldt	XS631100>630019>\$1
635034	CLRNDA 5 161.0	560001	NODAWAYCO 161.0	1	153	147.4	147.7	4.8%	S1399 to Humboldt	XS631095>636616>\$1
635034	CLRNDA 5 161.0	560001	NODAWAYCO 161.0	1	153	147.4	147.7	4.8%	S1399 to Humboldt	XS631101>630024>\$1
635034	CLRNDA 5 161.0	560001	NODAWAYCO 161.0	1	153	147.4	147.7	4.8%	S1399 to Humboldt	XS640113>640293>\$1
635034	CLRNDA 5 161.0	560001	NODAWAYCO 161.0	1	153	147.3	147.7	4.8%	S1399 to Humboldt	XS636673>633261>\$1
635034	CLRNDA 5 161.0	560001	NODAWAYCO 161.0	1	153	147.4	147.7	4.8%	S1399 to Humboldt	XS640066>640275>\$1
635034	CLRNDA 5 161.0	560001	NODAWAYCO 161.0	1	153	147.4	147.7	4.8%	S1399 to Humboldt	XS640051>640392>\$1
635034	CLRNDA 5 161.0	560001	NODAWAYCO 161.0	1	153	147.4	147.7	4.8%	S1399 to Humboldt	XS640126>640133>\$1
635034	CLRNDA 5 161.0	560001	NODAWAYCO 161.0	1	153	147.4	147.7	4.8%	S1399 to Humboldt	XS640068>640086>\$1
635034	CLRNDA 5 161.0	560001	NODAWAYCO 161.0	1	153	147.4	147.7	4.8%	S1399 to Humboldt	XS640066>640250>\$1
635034	CLRNDA 5 161.0	560001	NODAWAYCO 161.0	1	153	147.4	147.7	4.8%	S1399 to Humboldt	XS640167>659244>\$1
635034	CLRNDA 5 161.0	560001	NODAWAYCO 161.0	1	153	147.4	147.7	4.8%	S1399 to Humboldt	XS636421>636422>\$1
635034	CLRNDA 5 161.0	560001	NODAWAYCO 161.0	1	153	147.4	147.7	4.8%	S1399 to Humboldt	XS636616>636618>\$2
635034	CLRNDA 5 161.0	560001	NODAWAYCO 161.0	1	153	147.4	147.7	4.8%	S1399 to Humboldt	XS636300>636301>\$1

635034	CLRNDA 5	161.0	560001	NODAWAYCO	161.0	1	153	147.4	147.7	4.8%	S1399 to Humboldt	XS640126>640127>643036\$1
635034	CLRNDA 5	161.0	560001	NODAWAYCO	161.0	1	153	147.4	147.7	4.8%	S1399 to Humboldt	XS640149>640293>\$1
635034	CLRNDA 5	161.0	560001	NODAWAYCO	161.0	1	153	147.4	147.7	4.8%	S1399 to Humboldt	XS640157>640402>\$1
635034	CLRNDA 5	161.0	560001	NODAWAYCO	161.0	1	153	147.4	147.7	4.8%	S1399 to Humboldt	XS640144>640407>\$1
635034	CLRNDA 5	161.0	560001	NODAWAYCO	161.0	1	153	147.4	147.7	4.8%	S1399 to Humboldt	XS636420>636421>\$1
635034	CLRNDA 5	161.0	560001	NODAWAYCO	161.0	1	153	147.3	147.7	4.8%	S1399 to Humboldt	XS640109>652311>\$1
635034	CLRNDA 5	161.0	560001	NODAWAYCO	161.0	1	153	147.4	147.7	4.8%	S1399 to Humboldt	XS636210>636220>\$1
635034	CLRNDA 5	161.0	560001	NODAWAYCO	161.0	1	153	147.4	147.7	4.8%	S1399 to Humboldt	XS636601>636694>\$1
635034	CLRNDA 5	161.0	560001	NODAWAYCO	161.0	1	153	147.4	147.7	4.8%	S1399 to Humboldt	XS640068>640091>\$1
635034	CLRNDA 5	161.0	560001	NODAWAYCO	161.0	1	153	147.3	147.7	4.8%	S1399 to Humboldt	XS640100>640194>\$1
635034	CLRNDA 5	161.0	560001	NODAWAYCO	161.0	1	153	147.4	147.7	4.8%	S1399 to Humboldt	XS640147>640397>\$1
635034	CLRNDA 5	161.0	560001	NODAWAYCO	161.0	1	153	147.4	147.7	4.8%	S1399 to Humboldt	XS636616>636617>\$1
635034	CLRNDA 5	161.0	560001	NODAWAYCO	161.0	1	153	147.4	147.7	4.8%	S1399 to Humboldt	XS636220>636221>\$1
635034	CLRNDA 5	161.0	560001	NODAWAYCO	161.0	1	153	147.4	147.7	4.8%	S1399 to Humboldt	XS640089>640259>\$1
635034	CLRNDA 5	161.0	560001	NODAWAYCO	161.0	1	153	147.4	147.7	4.8%	S1399 to Humboldt	XS636601>636656>\$1
635034	CLRNDA 5	161.0	560001	NODAWAYCO	161.0	1	153	147.4	147.7	4.8%	S1399 to Humboldt	XS640063>640201>\$1
635034	CLRNDA 5	161.0	560001	NODAWAYCO	161.0	1	153	147.3	147.7	4.8%	S1399 to Humboldt	XS640093>640102>\$1
635034	CLRNDA 5	161.0	560001	NODAWAYCO	161.0	1	153	147.3	147.7	4.8%	S1399 to Humboldt	XS636670>636673>\$1
635034	CLRNDA 5	161.0	560001	NODAWAYCO	161.0	1	153	147.4	147.7	4.8%	S1399 to Humboldt	XS640124>640328>\$1
635034	CLRNDA 5	161.0	560001	NODAWAYCO	161.0	1	153	147.4	147.7	4.8%	S1399 to Humboldt	XS640089>640098>\$1
635034	CLRNDA 5	161.0	560001	NODAWAYCO	161.0	1	153	147.4	147.7	4.8%	S1399 to Humboldt	XS636600>636635>\$1
635034	CLRNDA 5	161.0	560001	NODAWAYCO	161.0	1	153	147.4	147.7	4.8%	S1399 to Humboldt	XS640155>640402>\$1
635034	CLRNDA 5	161.0	560001	NODAWAYCO	161.0	1	153	147.4	147.7	4.8%	S1399 to Humboldt	XS636616>636675>\$1
635034	CLRNDA 5	161.0	560001	NODAWAYCO	161.0	1	153	147.4	147.7	4.8%	S1399 to Humboldt	XS640155>650269>\$1
635034	CLRNDA 5	161.0	560001	NODAWAYCO	161.0	1	153	147.4	147.7	4.8%	S1399 to Humboldt	XS636425>636426>\$1
635034	CLRNDA 5	161.0	560001	NODAWAYCO	161.0	1	153	147.4	147.7	4.8%	S1399 to Humboldt	XS636600>636601>\$1
635034	CLRNDA 5	161.0	560001	NODAWAYCO	161.0	1	153	147.3	147.7	4.8%	S1399 to Humboldt	XS640056>640323>\$1

635034	CLRND 5	161.0	560001	NODAWAYCO	161.0	1	153	147.4	147.7	4.8%	S1399 to Humboldt	XS640159>640282>\$1
635034	CLRND 5	161.0	560001	NODAWAYCO	161.0	1	153	147.4	147.7	4.8%	S1399 to Humboldt	XS636616>636680>\$1
635034	CLRND 5	161.0	560001	NODAWAYCO	161.0	1	153	147.4	147.7	4.8%	S1399 to Humboldt	XS636230>656191>\$1
635034	CLRND 5	161.0	560001	NODAWAYCO	161.0	1	153	147.4	147.7	4.8%	S1399 to Humboldt	XS636670>636671>\$3
635034	CLRND 5	161.0	560001	NODAWAYCO	161.0	1	153	147.4	147.7	4.8%	S1399 to Humboldt	XS636616>636678>\$1
635034	CLRND 5	161.0	560001	NODAWAYCO	161.0	1	153	147.3	147.7	4.8%	S1399 to Humboldt	XS640056>642068>\$1
635034	CLRND 5	161.0	560001	NODAWAYCO	161.0	1	153	147.4	147.7	4.8%	S1399 to Humboldt	XS640091>659132>\$1
635034	CLRND 5	161.0	560001	NODAWAYCO	161.0	1	153	147.3	147.7	4.8%	S1399 to Humboldt	XS640054>640318>\$1
635034	CLRND 5	161.0	560001	NODAWAYCO	161.0	1	153	147.4	147.7	4.8%	S1399 to Humboldt	XS640100>640269>\$1
635034	CLRND 5	161.0	560001	NODAWAYCO	161.0	1	153	147.3	147.7	4.8%	S1399 to Humboldt	XS636672>348915>\$1
635034	CLRND 5	161.0	560001	NODAWAYCO	161.0	1	153	147.4	147.7	4.8%	S1399 to Humboldt	XS640054>640181>\$1
635034	CLRND 5	161.0	560001	NODAWAYCO	161.0	1	153	147.4	147.7	4.8%	S1399 to Humboldt	XS640163>640387>\$1
635034	CLRND 5	161.0	560001	NODAWAYCO	161.0	1	153	147.4	147.7	4.8%	S1399 to Humboldt	XS636668>636694>\$1
635034	CLRND 5	161.0	560001	NODAWAYCO	161.0	1	153	147.4	147.7	4.8%	S1399 to Humboldt	XS636601>636602>\$1
635034	CLRND 5	161.0	560001	NODAWAYCO	161.0	1	153	147.3	147.7	4.8%	S1399 to Humboldt	XS640153>640174>\$1
635034	CLRND 5	161.0	560001	NODAWAYCO	161.0	1	153	147.4	147.7	4.8%	S1399 to Humboldt	XS636235>636236>\$1
635034	CLRND 5	161.0	560001	NODAWAYCO	161.0	1	153	147.3	147.7	4.8%	S1399 to Humboldt	XS636225>638030>\$1
635034	CLRND 5	161.0	560001	NODAWAYCO	161.0	1	153	147.3	147.7	4.8%	S1399 to Humboldt	XS640161>640250>\$1
635034	CLRND 5	161.0	560001	NODAWAYCO	161.0	1	153	147.4	147.7	4.8%	S1399 to Humboldt	XS640063>640411>\$1
635034	CLRND 5	161.0	560001	NODAWAYCO	161.0	1	153	147.3	147.7	4.8%	S1399 to Humboldt	XS640153>640278>\$1
635034	CLRND 5	161.0	560001	NODAWAYCO	161.0	1	153	147.3	147.7	4.8%	S1399 to Humboldt	XS640093>640330>\$1
635034	CLRND 5	161.0	560001	NODAWAYCO	161.0	1	153	147.4	147.7	4.8%	S1399 to Humboldt	XS640127>640136>\$1
635034	CLRND 5	161.0	560001	NODAWAYCO	161.0	1	153	147.4	147.7	4.8%	S1399 to Humboldt	XS640103>640256>\$1
635034	CLRND 5	161.0	560001	NODAWAYCO	161.0	1	153	147.4	147.7	4.8%	S1399 to Humboldt	XS638000>638001>\$1
635034	CLRND 5	161.0	560001	NODAWAYCO	161.0	1	153	147.3	147.7	4.8%	S1399 to Humboldt	XS640076>640088>\$2
635034	CLRND 5	161.0	560001	NODAWAYCO	161.0	1	153	147.4	147.7	4.8%	S1399 to Humboldt	XS636650>636651>\$1
635034	CLRND 5	161.0	560001	NODAWAYCO	161.0	1	153	147.3	147.7	4.8%	S1399 to Humboldt	XS640076>640088>\$1

635034	CLRND 5	161.0	560001	NODAWAYCO	161.0	1	153	147.4	147.7	4.8%	S1399 to Humboldt	XS638030>638031>\$1
635034	CLRND 5	161.0	560001	NODAWAYCO	161.0	1	153	147.4	147.7	4.8%	S1399 to Humboldt	XS636650>636651>\$2
635034	CLRND 5	161.0	560001	NODAWAYCO	161.0	1	153	147.4	147.7	4.8%	S1399 to Humboldt	XS640082>640167>\$1
635034	CLRND 5	161.0	560001	NODAWAYCO	161.0	1	153	147.4	147.7	4.8%	S1399 to Humboldt	XS640103>640242>\$2
635034	CLRND 5	161.0	560001	NODAWAYCO	161.0	1	153	147.4	147.7	4.8%	S1399 to Humboldt	XS640107>640345>\$1
635034	CLRND 5	161.0	560001	NODAWAYCO	161.0	1	153	147.3	147.7	4.8%	S1399 to Humboldt	XS640174>640178>\$1
635034	CLRND 5	161.0	560001	NODAWAYCO	161.0	1	153	147.4	147.7	4.8%	S1399 to Humboldt	XS636401>636402>\$2
635034	CLRND 5	161.0	560001	NODAWAYCO	161.0	1	153	147.4	147.7	4.8%	S1399 to Humboldt	XS640084>640149>\$1
635034	CLRND 5	161.0	560001	NODAWAYCO	161.0	1	153	147.4	147.7	4.8%	S1399 to Humboldt	XS636610>636611>\$1
635034	CLRND 5	161.0	560001	NODAWAYCO	161.0	1	153	147.4	147.7	4.8%	S1399 to Humboldt	XS636650>636657>\$1
635034	CLRND 5	161.0	560001	NODAWAYCO	161.0	1	153	147.4	147.7	4.8%	S1399 to Humboldt	XS640133>640134>640135\$1
635034	CLRND 5	161.0	560001	NODAWAYCO	161.0	1	153	147.4	147.7	4.8%	S1399 to Humboldt	XS640134>640136>\$1
635034	CLRND 5	161.0	560001	NODAWAYCO	161.0	1	153	147.4	147.7	4.8%	S1399 to Humboldt	XS640080>640212>\$1
635034	CLRND 5	161.0	560001	NODAWAYCO	161.0	1	153	147.4	147.7	4.8%	S1399 to Humboldt	XS636204>636210>\$1
635034	CLRND 5	161.0	560001	NODAWAYCO	161.0	1	153	147.4	147.7	4.8%	S1399 to Humboldt	XS640080>640387>\$1
635034	CLRND 5	161.0	560001	NODAWAYCO	161.0	1	153	147.3	147.7	4.8%	S1399 to Humboldt	XS636640>636645>\$1
635034	CLRND 5	161.0	560001	NODAWAYCO	161.0	1	153	147.3	147.7	4.8%	S1399 to Humboldt	XS636690>636691>\$1
635034	CLRND 5	161.0	560001	NODAWAYCO	161.0	1	153	147.4	147.7	4.8%	S1399 to Humboldt	XS640105>640178>\$1
635034	CLRND 5	161.0	560001	NODAWAYCO	161.0	1	153	147.4	147.7	4.8%	S1399 to Humboldt	XS640178>640372>\$1
635034	CLRND 5	161.0	560001	NODAWAYCO	161.0	1	153	147.4	147.7	4.8%	S1399 to Humboldt	XS640136>640151>\$1
635034	CLRND 5	161.0	560001	NODAWAYCO	161.0	1	153	147.3	147.7	4.8%	S1399 to Humboldt	XS640076>640361>\$1
635034	CLRND 5	161.0	560001	NODAWAYCO	161.0	1	153	147.3	147.7	4.8%	S1399 to Humboldt	XS636691>636693>\$1
635034	CLRND 5	161.0	560001	NODAWAYCO	161.0	1	153	147.3	147.7	4.8%	S1399 to Humboldt	XS640178>640272>\$1
635034	CLRND 5	161.0	560001	NODAWAYCO	161.0	1	153	147.3	147.7	4.8%	S1399 to Humboldt	XS640105>640106>\$1
635034	CLRND 5	161.0	560001	NODAWAYCO	161.0	1	153	147.4	147.7	4.8%	S1399 to Humboldt	XS636692>636693>\$1
635034	CLRND 5	161.0	560001	NODAWAYCO	161.0	1	153	147.3	147.7	4.8%	S1399 to Humboldt	XS640133>652509>\$1
635034	CLRND 5	161.0	560001	NODAWAYCO	161.0	1	153	147.3	147.7	4.8%	S1399 to Humboldt	XS640078>640400>\$1

635034	CLRND 5	161.0	560001	NODAWAYCO	161.0	1	153	147.4	147.7	4.8%	S1399 to Humboldt	XS640084>652511>\$1
635034	CLRND 5	161.0	560001	NODAWAYCO	161.0	1	153	147.4	147.7	4.8%	S1399 to Humboldt	XS636210>636211>\$1
635034	CLRND 5	161.0	560001	NODAWAYCO	161.0	1	153	147.4	147.7	4.8%	S1399 to Humboldt	XS640173>647976>\$1
635034	CLRND 5	161.0	560001	NODAWAYCO	161.0	1	153	147.3	147.7	4.8%	S1399 to Humboldt	XS640072>640296>\$1
635034	CLRND 5	161.0	560001	NODAWAYCO	161.0	1	153	147.4	147.7	4.8%	S1399 to Humboldt	XS640109>640147>\$1
635034	CLRND 5	161.0	560001	NODAWAYCO	161.0	1	153	147.4	147.7	4.8%	S1399 to Humboldt	XS636656>636657>\$1
635034	CLRND 5	161.0	560001	NODAWAYCO	161.0	1	153	147.3	147.7	4.8%	S1399 to Humboldt	XS636615>636616>636619\$1
635034	CLRND 5	161.0	560001	NODAWAYCO	161.0	1	153	147.4	147.7	4.8%	S1399 to Humboldt	XS636605>270867>\$1
635034	CLRND 5	161.0	560001	NODAWAYCO	161.0	1	153	147.4	147.7	4.8%	S1399 to Humboldt	XS640173>640409>\$1
635034	CLRND 5	161.0	560001	NODAWAYCO	161.0	1	153	147.3	147.7	4.8%	S1399 to Humboldt	XS640070>640163>\$1
635034	CLRND 5	161.0	560001	NODAWAYCO	161.0	1	153	147.4	147.7	4.8%	S1399 to Humboldt	XS640103>640242>\$1
635034	CLRND 5	161.0	560001	NODAWAYCO	161.0	1	153	147.4	147.7	4.8%	S1399 to Humboldt	XS640131>640133>\$1
635034	CLRND 5	161.0	560001	NODAWAYCO	161.0	1	153	147.4	147.7	4.8%	S1399 to Humboldt	XS636410>636422>\$1
635034	CLRND 5	161.0	560001	NODAWAYCO	161.0	1	153	147.4	147.7	4.8%	S1399 to Humboldt	XS638030>638040>\$1
635034	CLRND 5	161.0	560001	NODAWAYCO	161.0	1	153	147.4	147.7	4.8%	S1399 to Humboldt	XS640173>647976>\$4
635034	CLRND 5	161.0	560001	NODAWAYCO	161.0	1	153	147.3	147.7	4.8%	S1399 to Humboldt	XS640102>640103>643029\$1
635034	CLRND 5	161.0	560001	NODAWAYCO	161.0	1	153	147.4	147.7	4.8%	S1399 to Humboldt	XS640109>640405>\$1
635034	CLRND 5	161.0	560001	NODAWAYCO	161.0	1	153	147.4	147.7	4.8%	S1399 to Humboldt	XS636401>636402>\$1
635034	CLRND 5	161.0	560001	NODAWAYCO	161.0	1	153	147.3	147.7	4.8%	S1399 to Humboldt	XS640300>640409>\$1
635034	CLRND 5	161.0	560001	NODAWAYCO	161.0	1	153	147.3	147.7	4.8%	S1399 to Humboldt	XS640222>640313>\$1
635034	CLRND 5	161.0	560001	NODAWAYCO	161.0	1	153	147.3	147.7	4.8%	S1399 to Humboldt	XS640222>640224>\$1
635034	CLRND 5	161.0	560001	NODAWAYCO	161.0	1	153	147.4	147.7	4.8%	S1399 to Humboldt	XS640220>640368>\$1
635034	CLRND 5	161.0	560001	NODAWAYCO	161.0	1	153	147.4	147.7	4.8%	S1399 to Humboldt	XS640326>640365>\$1
635034	CLRND 5	161.0	560001	NODAWAYCO	161.0	1	153	147.3	147.7	4.8%	S1399 to Humboldt	XS640302>659134>\$1
635034	CLRND 5	161.0	560001	NODAWAYCO	161.0	1	153	147.4	147.7	4.8%	S1399 to Humboldt	XS640227>640386>\$1
635034	CLRND 5	161.0	560001	NODAWAYCO	161.0	1	153	147.4	147.7	4.8%	S1399 to Humboldt	XS642068>642071>\$1
635034	CLRND 5	161.0	560001	NODAWAYCO	161.0	1	153	147.3	147.7	4.8%	S1399 to Humboldt	XS640293>640444>\$1

635034	CLRND 5	161.0	560001	NODAWAYCO	161.0	1	153	147.4	147.7	4.8%	S1399 to Humboldt	XS640234>640235>643087\$1
635034	CLRND 5	161.0	560001	NODAWAYCO	161.0	1	153	147.4	147.7	4.8%	S1399 to Humboldt	XS640228>640363>\$1
635034	CLRND 5	161.0	560001	NODAWAYCO	161.0	1	153	147.4	147.7	4.8%	S1399 to Humboldt	XS642070>642073>\$1
635034	CLRND 5	161.0	560001	NODAWAYCO	161.0	1	153	147.4	147.7	4.8%	S1399 to Humboldt	XS640228>640296>\$1
635034	CLRND 5	161.0	560001	NODAWAYCO	161.0	1	153	147.3	147.7	4.8%	S1399 to Humboldt	XS640227>640228>643083\$1
635034	CLRND 5	161.0	560001	NODAWAYCO	161.0	1	153	147.4	147.7	4.8%	S1399 to Humboldt	XS640228>640298>\$1
635034	CLRND 5	161.0	560001	NODAWAYCO	161.0	1	153	147.3	147.7	4.8%	S1399 to Humboldt	XS640318>640444>\$1
635034	CLRND 5	161.0	560001	NODAWAYCO	161.0	1	153	147.4	147.7	4.8%	S1399 to Humboldt	XS640210>640392>\$1
635034	CLRND 5	161.0	560001	NODAWAYCO	161.0	1	153	147.3	147.7	4.8%	S1399 to Humboldt	XS645030>645033>\$1
635034	CLRND 5	161.0	560001	NODAWAYCO	161.0	1	153	147.4	147.7	4.8%	S1399 to Humboldt	XS640370>659186>\$1
635034	CLRND 5	161.0	560001	NODAWAYCO	161.0	1	153	147.4	147.7	4.8%	S1399 to Humboldt	XS640208>640426>\$1
635034	CLRND 5	161.0	560001	NODAWAYCO	161.0	1	153	147.4	147.7	4.8%	S1399 to Humboldt	XS640323>640331>\$1
635034	CLRND 5	161.0	560001	NODAWAYCO	161.0	1	153	147.4	147.7	4.8%	S1399 to Humboldt	XS640206>640313>\$1
635034	CLRND 5	161.0	560001	NODAWAYCO	161.0	1	153	147.4	147.7	4.8%	S1399 to Humboldt	XS640201>642072>\$1
635034	CLRND 5	161.0	560001	NODAWAYCO	161.0	1	153	147.4	147.7	4.8%	S1399 to Humboldt	XS640210>640351>\$1
635034	CLRND 5	161.0	560001	NODAWAYCO	161.0	1	153	147.4	147.7	4.8%	S1399 to Humboldt	XS640215>640313>\$1
635034	CLRND 5	161.0	560001	NODAWAYCO	161.0	1	153	147.4	147.7	4.8%	S1399 to Humboldt	XS640218>640220>\$1
635034	CLRND 5	161.0	560001	NODAWAYCO	161.0	1	153	147.4	147.7	4.8%	S1399 to Humboldt	XS640375>640411>\$1
635034	CLRND 5	161.0	560001	NODAWAYCO	161.0	1	153	147.3	147.7	4.8%	S1399 to Humboldt	XS640312>640313>640315\$1
635034	CLRND 5	161.0	560001	NODAWAYCO	161.0	1	153	147.4	147.7	4.8%	S1399 to Humboldt	XS640215>640313>\$2
635034	CLRND 5	161.0	560001	NODAWAYCO	161.0	1	153	147.4	147.7	4.8%	S1399 to Humboldt	XS640212>652511>\$1
635034	CLRND 5	161.0	560001	NODAWAYCO	161.0	1	153	147.4	147.7	4.8%	S1399 to Humboldt	XS640372>641087>\$1
635034	CLRND 5	161.0	560001	NODAWAYCO	161.0	1	153	147.4	147.7	4.8%	S1399 to Humboldt	XS640214>641088>643075\$1
635034	CLRND 5	161.0	560001	NODAWAYCO	161.0	1	153	147.4	147.7	4.8%	S1399 to Humboldt	XS640238>640013>\$1
635034	CLRND 5	161.0	560001	NODAWAYCO	161.0	1	153	147.4	147.7	4.8%	S1399 to Humboldt	XS640404>640405>640406\$1
635034	CLRND 5	161.0	560001	NODAWAYCO	161.0	1	153	147.4	147.7	4.8%	S1399 to Humboldt	XS640259>640353>\$1
635034	CLRND 5	161.0	560001	NODAWAYCO	161.0	1	153	147.3	147.7	4.8%	S1399 to Humboldt	XS640302>659132>643115\$1

635034	CLRNDA 5	161.0	560001	NODAWAYCO	161.0	1	153	147.4	147.7	4.8%	S1399 to Humboldt	XS640256>640331>\$1
635034	CLRNDA 5	161.0	560001	NODAWAYCO	161.0	1	153	147.4	147.7	4.8%	S1399 to Humboldt	XS640411>640413>\$1
635034	CLRNDA 5	161.0	560001	NODAWAYCO	161.0	1	153	147.4	147.7	4.8%	S1399 to Humboldt	XS640271>640272>640274\$1
635034	CLRNDA 5	161.0	560001	NODAWAYCO	161.0	1	153	147.3	147.7	4.8%	S1399 to Humboldt	XS640261>640321>\$1
635034	CLRNDA 5	161.0	560001	NODAWAYCO	161.0	1	153	147.4	147.7	4.8%	S1399 to Humboldt	XS640265>640370>\$1
635034	CLRNDA 5	161.0	560001	NODAWAYCO	161.0	1	153	147.4	147.7	4.8%	S1399 to Humboldt	XS640263>640298>\$1
635034	CLRNDA 5	161.0	560001	NODAWAYCO	161.0	1	153	147.4	147.7	4.8%	S1399 to Humboldt	XS642066>642072>\$1
635034	CLRNDA 5	161.0	560001	NODAWAYCO	161.0	1	153	147.4	147.7	4.8%	S1399 to Humboldt	XS640242>640407>\$1
635034	CLRNDA 5	161.0	560001	NODAWAYCO	161.0	1	153	147.4	147.7	4.8%	S1399 to Humboldt	XS640242>640244>\$1
635034	CLRNDA 5	161.0	560001	NODAWAYCO	161.0	1	153	147.3	147.7	4.8%	S1399 to Humboldt	XS640284>640347>\$1
635034	CLRNDA 5	161.0	560001	NODAWAYCO	161.0	1	153	147.4	147.7	4.8%	S1399 to Humboldt	XS640240>640244>\$1
635034	CLRNDA 5	161.0	560001	NODAWAYCO	161.0	1	153	147.4	147.7	4.8%	S1399 to Humboldt	XS640238>640287>\$1
635034	CLRNDA 5	161.0	560001	NODAWAYCO	161.0	1	153	147.4	147.7	4.8%	S1399 to Humboldt	XS640292>647961>\$1
635034	CLRNDA 5	161.0	560001	NODAWAYCO	161.0	1	153	147.4	147.7	4.8%	S1399 to Humboldt	XS640226>640228>640231\$1
635034	CLRNDA 5	161.0	560001	NODAWAYCO	161.0	1	153	147.4	147.7	4.8%	S1399 to Humboldt	XS640235>640361>\$1
635034	CLRNDA 5	161.0	560001	NODAWAYCO	161.0	1	153	147.3	147.7	4.8%	S1399 to Humboldt	XS640281>640336>\$1
635034	CLRNDA 5	161.0	560001	NODAWAYCO	161.0	1	153	147.4	147.7	4.8%	S1399 to Humboldt	XS640250>640261>\$1
635034	CLRNDA 5	161.0	560001	NODAWAYCO	161.0	1	153	147.3	147.7	4.8%	S1399 to Humboldt	XS640282>640321>\$1
635034	CLRNDA 5	161.0	560001	NODAWAYCO	161.0	1	153	147.3	147.7	4.8%	S1399 to Humboldt	XS640394>640395>\$1
635034	CLRNDA 5	161.0	560001	NODAWAYCO	161.0	1	153	147.3	147.7	4.8%	S1399 to Humboldt	XS640361>647966>\$1
635034	CLRNDA 5	161.0	560001	NODAWAYCO	161.0	1	153	147.4	147.7	4.8%	S1399 to Humboldt	XS640328>640340>\$1
635034	CLRNDA 5	161.0	560001	NODAWAYCO	161.0	1	153	147.4	147.7	4.8%	S1399 to Humboldt	XS640184>640286>\$3
635034	CLRNDA 5	161.0	560001	NODAWAYCO	161.0	1	153	147.4	147.7	4.8%	S1399 to Humboldt	XS640200>640201>643070\$2
635034	CLRNDA 5	161.0	560001	NODAWAYCO	161.0	1	153	147.4	147.7	4.8%	S1399 to Humboldt	XS640340>640375>\$1
635034	CLRNDA 5	161.0	560001	NODAWAYCO	161.0	1	153	147.4	147.7	4.8%	S1399 to Humboldt	XS640200>640214>\$1
635034	CLRNDA 5	161.0	560001	NODAWAYCO	161.0	1	153	147.4	147.7	4.8%	S1399 to Humboldt	XS640184>640286>\$1
635034	CLRNDA 5	161.0	560001	NODAWAYCO	161.0	1	153	147.4	147.7	4.8%	S1399 to Humboldt	XS640192>659152>\$1

635034	CLRND 5	161.0	560001	NODAWAYCO	161.0	1	153	147.4	147.7	4.8%	S1399 to Humboldt	XS640184>640286>\$2
635034	CLRND 5	161.0	560001	NODAWAYCO	161.0	1	153	147.4	147.7	4.8%	S1399 to Humboldt	XS640200>652571>643071\$3
635034	CLRND 5	161.0	560001	NODAWAYCO	161.0	1	153	147.4	147.7	4.8%	S1399 to Humboldt	XS640184>640302>\$1
635034	CLRND 5	161.0	560001	NODAWAYCO	161.0	1	153	147.4	147.7	4.8%	S1399 to Humboldt	XS640201>642071>\$1
635034	CLRND 5	161.0	560001	NODAWAYCO	161.0	1	153	147.4	147.7	4.8%	S1399 to Humboldt	XS640196>640238>\$1
635034	CLRND 5	161.0	560001	NODAWAYCO	161.0	1	153	147.4	147.7	4.8%	S1399 to Humboldt	XS640357>640363>\$1
635034	CLRND 5	161.0	560001	NODAWAYCO	161.0	1	153	147.4	147.7	4.8%	S1399 to Humboldt	XS640331>640383>\$1
635034	CLRND 5	161.0	560001	NODAWAYCO	161.0	1	153	147.4	147.7	4.8%	S1399 to Humboldt	XS645451>645459>\$1
635034	CLRND 5	161.0	560001	NODAWAYCO	161.0	1	153	147.4	147.7	4.8%	S1399 to Humboldt	XS640200>640201>640203\$1
635034	CLRND 5	161.0	560001	NODAWAYCO	161.0	1	153	147.3	147.7	4.8%	S1399 to Humboldt	XS645451>645454>\$1
635034	CLRND 5	161.0	560001	NODAWAYCO	161.0	1	153	147.4	147.7	4.8%	S1399 to Humboldt	XS647105>647901>\$1
635034	CLRND 5	161.0	560001	NODAWAYCO	161.0	1	153	147.4	147.7	4.8%	S1399 to Humboldt	XS650270>650272>\$1
635034	CLRND 5	161.0	560001	NODAWAYCO	161.0	1	153	147.4	147.7	4.8%	S1399 to Humboldt	XS647104>647939>\$1
635034	CLRND 5	161.0	560001	NODAWAYCO	161.0	1	153	147.4	147.7	4.8%	S1399 to Humboldt	XS650270>650273>\$1
635034	CLRND 5	161.0	560001	NODAWAYCO	161.0	1	153	147.4	147.7	4.8%	S1399 to Humboldt	XS650233>650259>\$1
635034	CLRND 5	161.0	560001	NODAWAYCO	161.0	1	153	147.4	147.7	4.8%	S1399 to Humboldt	XS647906>647938>\$1
635034	CLRND 5	161.0	560001	NODAWAYCO	161.0	1	153	147.4	147.7	4.8%	S1399 to Humboldt	XS650233>650240>\$1
635034	CLRND 5	161.0	560001	NODAWAYCO	161.0	1	153	147.4	147.7	4.8%	S1399 to Humboldt	XS650271>650274>\$1
635034	CLRND 5	161.0	560001	NODAWAYCO	161.0	1	153	147.4	147.7	4.8%	S1399 to Humboldt	XS650260>650262>\$1
635034	CLRND 5	161.0	560001	NODAWAYCO	161.0	1	153	147.4	147.7	4.8%	S1399 to Humboldt	XS646206>646244>\$1
635034	CLRND 5	161.0	560001	NODAWAYCO	161.0	1	153	147.4	147.7	4.8%	S1399 to Humboldt	XS646234>646235>\$1
635034	CLRND 5	161.0	560001	NODAWAYCO	161.0	1	153	147.4	147.7	4.8%	S1399 to Humboldt	XS647105>647910>\$1
635034	CLRND 5	161.0	560001	NODAWAYCO	161.0	1	153	147.4	147.7	4.8%	S1399 to Humboldt	XS647111>647967>\$1
635034	CLRND 5	161.0	560001	NODAWAYCO	161.0	1	153	147.4	147.7	4.8%	S1399 to Humboldt	XS647006>647916>\$1
635034	CLRND 5	161.0	560001	NODAWAYCO	161.0	1	153	147.4	147.7	4.8%	S1399 to Humboldt	XS650238>650270>\$1
635034	CLRND 5	161.0	560001	NODAWAYCO	161.0	1	153	147.4	147.7	4.8%	S1399 to Humboldt	XS647908>647913>\$1
635034	CLRND 5	161.0	560001	NODAWAYCO	161.0	1	153	147.3	147.7	4.8%	S1399 to Humboldt	XS646209>646231>\$2

635034	CLRND 5	161.0	560001	NODAWAYCO	161.0	1	153	147.3	147.7	4.8%	S1399 to Humboldt	XS646209>646231>\$1
635034	CLRND 5	161.0	560001	NODAWAYCO	161.0	1	153	147.4	147.7	4.8%	S1399 to Humboldt	XS650208>650212>\$1
635034	CLRND 5	161.0	560001	NODAWAYCO	161.0	1	153	147.4	147.7	4.8%	S1399 to Humboldt	XS647900>647985>\$1
635034	CLRND 5	161.0	560001	NODAWAYCO	161.0	1	153	147.3	147.7	4.8%	S1399 to Humboldt	XS650271>650285>\$1
635034	CLRND 5	161.0	560001	NODAWAYCO	161.0	1	153	147.4	147.7	4.8%	S1399 to Humboldt	XS647900>647914>\$1
635034	CLRND 5	161.0	560001	NODAWAYCO	161.0	1	153	147.4	147.7	4.8%	S1399 to Humboldt	XS646237>646345>\$1
635034	CLRND 5	161.0	560001	NODAWAYCO	161.0	1	153	147.4	147.7	4.8%	S1399 to Humboldt	XS646201>646206>\$1
635034	CLRND 5	161.0	560001	NODAWAYCO	161.0	1	153	147.4	147.7	4.8%	S1399 to Humboldt	XS650283>650285>\$1
635034	CLRND 5	161.0	560001	NODAWAYCO	161.0	1	153	147.4	147.7	4.8%	S1399 to Humboldt	XS650228>650233>\$1
635034	CLRND 5	161.0	560001	NODAWAYCO	161.0	1	153	147.3	147.7	4.8%	S1399 to Humboldt	XS650205>650212>\$1
635034	CLRND 5	161.0	560001	NODAWAYCO	161.0	1	153	147.3	147.7	4.8%	S1399 to Humboldt	XS646235>646236>\$1
635034	CLRND 5	161.0	560001	NODAWAYCO	161.0	1	153	147.4	147.7	4.8%	S1399 to Humboldt	XS650229>650290>\$1
635034	CLRND 5	161.0	560001	NODAWAYCO	161.0	1	153	147.3	147.7	4.8%	S1399 to Humboldt	XS650205>650215>\$1
635034	CLRND 5	161.0	560001	NODAWAYCO	161.0	1	153	147.3	147.7	4.8%	S1399 to Humboldt	XS647901>647912>\$1
635034	CLRND 5	161.0	560001	NODAWAYCO	161.0	1	153	147.3	147.7	4.8%	S1399 to Humboldt	XS646201>647901>648201\$1
635034	CLRND 5	161.0	560001	NODAWAYCO	161.0	1	153	147.4	147.7	4.8%	S1399 to Humboldt	XS650257>650270>\$1
635034	CLRND 5	161.0	560001	NODAWAYCO	161.0	1	153	147.4	147.7	4.8%	S1399 to Humboldt	XS647921>647942>\$1
635034	CLRND 5	161.0	560001	NODAWAYCO	161.0	1	153	147.4	147.7	4.8%	S1399 to Humboldt	XS647921>647940>\$1
635034	CLRND 5	161.0	560001	NODAWAYCO	161.0	1	153	147.3	147.7	4.8%	S1399 to Humboldt	XS647919>647950>\$1
635034	CLRND 5	161.0	560001	NODAWAYCO	161.0	1	153	147.4	147.7	4.8%	S1399 to Humboldt	XS647928>647942>\$1
635034	CLRND 5	161.0	560001	NODAWAYCO	161.0	1	153	147.4	147.7	4.8%	S1399 to Humboldt	XS650259>650262>\$1
635034	CLRND 5	161.0	560001	NODAWAYCO	161.0	1	153	147.4	147.7	4.8%	S1399 to Humboldt	XS647968>647969>\$1
635034	CLRND 5	161.0	560001	NODAWAYCO	161.0	1	153	147.4	147.7	4.8%	S1399 to Humboldt	XS647090>647982>\$1
635034	CLRND 5	161.0	560001	NODAWAYCO	161.0	1	153	147.4	147.7	4.8%	S1399 to Humboldt	XS647969>647974>\$1
635034	CLRND 5	161.0	560001	NODAWAYCO	161.0	1	153	147.4	147.7	4.8%	S1399 to Humboldt	XS647101>647975>\$1
635034	CLRND 5	161.0	560001	NODAWAYCO	161.0	1	153	147.4	147.7	4.8%	S1399 to Humboldt	XS647967>647968>\$1
635034	CLRND 5	161.0	560001	NODAWAYCO	161.0	1	153	147.3	147.7	4.8%	S1399 to Humboldt	XS646217>647917>648217\$1

635034	CLRNDA 5 161.0	560001	NODAWAYCO 161.0	1	153	147.4	147.7	4.8%	S1399 to Humboldt	XS647961>640320>\$1
635034	CLRNDA 5 161.0	560001	NODAWAYCO 161.0	1	153	147.4	147.7	4.8%	S1399 to Humboldt	XS650255>650274>\$1
635034	CLRNDA 5 161.0	560001	NODAWAYCO 161.0	1	153	147.4	147.7	4.8%	S1399 to Humboldt	XS650256>650260>\$1
635034	CLRNDA 5 161.0	560001	NODAWAYCO 161.0	1	153	147.4	147.7	4.8%	S1399 to Humboldt	XS647930>647939>\$1
635034	CLRNDA 5 161.0	560001	NODAWAYCO 161.0	1	153	147.4	147.7	4.8%	S1399 to Humboldt	XS650257>650258>\$1
635034	CLRNDA 5 161.0	560001	NODAWAYCO 161.0	1	153	147.4	147.7	4.8%	S1399 to Humboldt	XS646210>646217>\$1
635034	CLRNDA 5 161.0	560001	NODAWAYCO 161.0	1	153	147.4	147.7	4.8%	S1399 to Humboldt	XS647911>647913>\$1
635034	CLRNDA 5 161.0	560001	NODAWAYCO 161.0	1	153	147.4	147.7	4.8%	S1399 to Humboldt	XS646209>647909>648209\$1
635034	CLRNDA 5 161.0	560001	NODAWAYCO 161.0	1	153	147.4	147.7	4.8%	S1399 to Humboldt	XS647912>647924>\$1
635034	CLRNDA 5 161.0	560001	NODAWAYCO 161.0	1	153	147.4	147.7	4.8%	S1399 to Humboldt	XS650267>650272>\$1
635034	CLRNDA 5 161.0	560001	NODAWAYCO 161.0	1	153	147.4	147.7	4.8%	S1399 to Humboldt	XS647910>647923>\$1
635034	CLRNDA 5 161.0	560001	NODAWAYCO 161.0	1	153	147.3	147.7	4.8%	S1399 to Humboldt	XS647006>647928>\$1
635034	CLRNDA 5 161.0	560001	NODAWAYCO 161.0	1	153	147.4	147.7	4.8%	S1399 to Humboldt	XS650267>650273>\$1
635034	CLRNDA 5 161.0	560001	NODAWAYCO 161.0	1	153	147.4	147.7	4.8%	S1399 to Humboldt	XS647909>647939>\$1
635034	CLRNDA 5 161.0	560001	NODAWAYCO 161.0	1	153	147.4	147.7	4.8%	S1399 to Humboldt	XS647917>647918>\$1
635034	CLRNDA 5 161.0	560001	NODAWAYCO 161.0	1	153	147.4	147.7	4.8%	S1399 to Humboldt	XS647972>647982>\$1
635034	CLRNDA 5 161.0	560001	NODAWAYCO 161.0	1	153	147.4	147.7	4.8%	S1399 to Humboldt	XS646226>646237>\$1
635034	CLRNDA 5 161.0	560001	NODAWAYCO 161.0	1	153	147.4	147.7	4.8%	S1399 to Humboldt	XS647091>647427>\$1
635034	CLRNDA 5 161.0	560001	NODAWAYCO 161.0	1	153	147.4	147.7	4.8%	S1399 to Humboldt	XS647916>647940>\$1
635034	CLRNDA 5 161.0	560001	NODAWAYCO 161.0	1	153	147.4	147.7	4.8%	S1399 to Humboldt	XS647006>647938>\$1
635034	CLRNDA 5 161.0	560001	NODAWAYCO 161.0	1	153	147.4	147.7	4.8%	S1399 to Humboldt	XS647014>647846>\$1
635034	CLRNDA 5 161.0	560001	NODAWAYCO 161.0	1	153	147.3	147.7	4.8%	S1399 to Humboldt	XS650262>650267>\$1
635034	CLRNDA 5 161.0	560001	NODAWAYCO 161.0	1	153	147.4	147.7	4.8%	S1399 to Humboldt	XS647916>647917>\$1
635034	CLRNDA 5 161.0	560001	NODAWAYCO 161.0	1	153	147.4	147.7	4.8%	S1399 to Humboldt	XS646226>646252>\$1
635034	CLRNDA 5 161.0	560001	NODAWAYCO 161.0	1	153	147.3	147.7	4.8%	S1399 to Humboldt	XS647091>647984>\$1
635034	CLRNDA 5 161.0	560001	NODAWAYCO 161.0	1	153	147.4	147.7	4.8%	S1399 to Humboldt	XS647906>647924>\$1
635034	CLRNDA 5 161.0	560001	NODAWAYCO 161.0	1	153	147.3	147.7	4.8%	S1399 to Humboldt	XS652294>652295>\$1

635034	CLRND 5	161.0	560001	NODAWAYCO	161.0	1	153	147.4	147.7	4.8%	S1399 to Humboldt	XS647425>647426>\$1
635034	CLRND 5	161.0	560001	NODAWAYCO	161.0	1	153	147.4	147.7	4.8%	S1399 to Humboldt	XS652312>659197>\$1
635034	CLRND 5	161.0	560001	NODAWAYCO	161.0	1	153	147.4	147.7	4.8%	S1399 to Humboldt	XS650215>650228>\$1
635034	CLRND 5	161.0	560001	NODAWAYCO	161.0	1	153	147.4	147.7	4.8%	S1399 to Humboldt	XS650215>650226>\$1
635034	CLRND 5	161.0	560001	NODAWAYCO	161.0	1	153	147.3	147.7	4.8%	S1399 to Humboldt	XS647112>647113>\$1
635034	CLRND 5	161.0	560001	NODAWAYCO	161.0	1	153	147.4	147.7	4.8%	S1399 to Humboldt	XS647423>647424>\$1
635034	CLRND 5	161.0	560001	NODAWAYCO	161.0	1	153	147.4	147.7	4.8%	S1399 to Humboldt	XS647416>647421>\$1
635034	CLRND 5	161.0	560001	NODAWAYCO	161.0	1	153	147.4	147.7	4.8%	S1399 to Humboldt	XS650219>650240>\$1
635034	CLRND 5	161.0	560001	NODAWAYCO	161.0	1	153	147.4	147.7	4.8%	S1399 to Humboldt	XS646254>646281>\$1
635034	CLRND 5	161.0	560001	NODAWAYCO	161.0	1	153	147.3	147.7	4.8%	S1399 to Humboldt	XS646250>647950>648250\$1
635034	CLRND 5	161.0	560001	NODAWAYCO	161.0	1	153	147.4	147.7	4.8%	S1399 to Humboldt	XS647421>647427>\$1
635034	CLRND 5	161.0	560001	NODAWAYCO	161.0	1	153	147.4	147.7	4.8%	S1399 to Humboldt	XS650214>650226>\$1
635034	CLRND 5	161.0	560001	NODAWAYCO	161.0	1	153	147.4	147.7	4.8%	S1399 to Humboldt	XS647423>647427>\$1
635034	CLRND 5	161.0	560001	NODAWAYCO	161.0	1	153	147.3	147.7	4.8%	S1399 to Humboldt	XS652294>652538>\$1
635034	CLRND 5	161.0	560001	NODAWAYCO	161.0	1	153	147.4	147.7	4.8%	S1399 to Humboldt	XS650217>650230>\$1
635034	CLRND 5	161.0	560001	NODAWAYCO	161.0	1	153	147.4	147.7	4.8%	S1399 to Humboldt	XS650216>650230>\$1
635034	CLRND 5	161.0	560001	NODAWAYCO	161.0	1	153	147.3	147.7	4.8%	S1399 to Humboldt	XS652311>659236>\$1
635034	CLRND 5	161.0	560001	NODAWAYCO	161.0	1	153	147.4	147.7	4.8%	S1399 to Humboldt	XS647421>647422>\$1
635034	CLRND 5	161.0	560001	NODAWAYCO	161.0	1	153	147.4	147.7	4.8%	S1399 to Humboldt	XS647846>647983>\$1
635034	CLRND 5	161.0	560001	NODAWAYCO	161.0	1	153	147.4	147.7	4.8%	S1399 to Humboldt	XS647422>647424>\$1
635034	CLRND 5	161.0	560001	NODAWAYCO	161.0	1	153	147.4	147.7	4.8%	S1399 to Humboldt	XS650214>650216>\$1
635034	CLRND 5	161.0	560001	NODAWAYCO	161.0	1	153	147.4	147.7	4.8%	S1399 to Humboldt	XS300095>301168>\$2
635034	CLRND 5	161.0	560001	NODAWAYCO	161.0	1	153	147.4	147.7	4.8%	S1399 to Humboldt	XS300062>301159>\$1
635034	CLRND 5	161.0	560001	NODAWAYCO	161.0	1	153	147.4	147.7	4.8%	S1399 to Humboldt	XS300071>300692>\$1
635034	CLRND 5	161.0	560001	NODAWAYCO	161.0	1	153	147.3	147.7	4.8%	S1399 to Humboldt	XS300057>300618>\$1
635034	CLRND 5	161.0	560001	NODAWAYCO	161.0	1	153	147.4	147.7	4.8%	S1399 to Humboldt	MC1237-45-53
635034	CLRND 5	161.0	560001	NODAWAYCO	161.0	1	153	147.4	147.7	4.8%	S1399 to Humboldt	XS300062>300160>\$1

635034	CLRND 5	161.0	560001	NODAWAYCO	161.0	1	153	147.4	147.7	4.8%	S1399 to Humboldt	XS300095>301168>\$1
635034	CLRND 5	161.0	560001	NODAWAYCO	161.0	1	153	147.4	147.7	4.8%	S1399 to Humboldt	XS300089>300673>\$1
635034	CLRND 5	161.0	560001	NODAWAYCO	161.0	1	153	147.4	147.7	4.8%	S1399 to Humboldt	XS300056>301194>\$2
635034	CLRND 5	161.0	560001	NODAWAYCO	161.0	1	153	147.4	147.7	4.8%	S1399 to Humboldt	XS300096>301184>\$2
635034	CLRND 5	161.0	560001	NODAWAYCO	161.0	1	153	147.4	147.7	4.8%	S1399 to Humboldt	XS300035>338187>\$1
635034	CLRND 5	161.0	560001	NODAWAYCO	161.0	1	153	147.4	147.7	4.8%	S1399 to Humboldt	XS300086>301062>\$1
635034	CLRND 5	161.0	560001	NODAWAYCO	161.0	1	153	147.4	147.7	4.8%	S1399 to Humboldt	XS300056>301194>\$1
635034	CLRND 5	161.0	560001	NODAWAYCO	161.0	1	153	147.4	147.7	4.8%	S1399 to Humboldt	XS300070>300794>\$1
635034	CLRND 5	161.0	560001	NODAWAYCO	161.0	1	153	147.4	147.7	4.8%	S1399 to Humboldt	XS300035>300046>\$2
635034	CLRND 5	161.0	560001	NODAWAYCO	161.0	1	153	147.4	147.7	4.8%	S1399 to Humboldt	XS300070>300802>\$1
635034	CLRND 5	161.0	560001	NODAWAYCO	161.0	1	153	147.4	147.7	4.8%	S1399 to Humboldt	XS300096>301184>\$1
635034	CLRND 5	161.0	560001	NODAWAYCO	161.0	1	153	147.4	147.7	4.8%	S1399 to Humboldt	XS300035>300046>\$1
635034	CLRND 5	161.0	560001	NODAWAYCO	161.0	1	153	147.3	147.7	4.8%	S1399 to Humboldt	XS300059>300591>\$1
635034	CLRND 5	161.0	560001	NODAWAYCO	161.0	1	153	147.3	147.7	4.8%	S1399 to Humboldt	XS300092>301070>\$1
635034	CLRND 5	161.0	560001	NODAWAYCO	161.0	1	153	147.4	147.7	4.8%	S1399 to Humboldt	S993 GEN OFF
635034	CLRND 5	161.0	560001	NODAWAYCO	161.0	1	153	147.4	147.7	4.8%	S1399 to Humboldt	XS300072>301048>\$1
635034	CLRND 5	161.0	560001	NODAWAYCO	161.0	1	153	147.4	147.7	4.8%	S1399 to Humboldt	XS300060>300067>\$1
635034	CLRND 5	161.0	560001	NODAWAYCO	161.0	1	153	147.4	147.7	4.8%	S1399 to Humboldt	XS300072>300092>\$1
635034	CLRND 5	161.0	560001	NODAWAYCO	161.0	1	153	147.3	147.7	4.8%	S1399 to Humboldt	XS300074>301138>\$1
635034	CLRND 5	161.0	560001	NODAWAYCO	161.0	1	153	147.4	147.7	4.8%	S1399 to Humboldt	MC1226-98
635034	CLRND 5	161.0	560001	NODAWAYCO	161.0	1	153	147.4	147.7	4.8%	S1399 to Humboldt	XS300059>300608>\$1
635034	CLRND 5	161.0	560001	NODAWAYCO	161.0	1	153	147.3	147.7	4.8%	S1399 to Humboldt	XS300091>300302>\$1
635034	CLRND 5	161.0	560001	NODAWAYCO	161.0	1	153	147.4	147.7	4.8%	S1399 to Humboldt	XS300059>300597>\$1
635034	CLRND 5	161.0	560001	NODAWAYCO	161.0	1	153	147.4	147.7	4.8%	S1399 to Humboldt	XS300059>345941>\$1
635034	CLRND 5	161.0	560001	NODAWAYCO	161.0	1	153	147.4	147.7	4.8%	S1399 to Humboldt	TRF-KELLY
635034	CLRND 5	161.0	560001	NODAWAYCO	161.0	1	153	147.4	147.7	4.8%	S1399 to Humboldt	XS300092>301065>\$2
635034	CLRND 5	161.0	560001	NODAWAYCO	161.0	1	153	147.4	147.7	4.8%	S1399 to Humboldt	XS300092>301065>\$1

635034	CLRND 5	161.0	560001	NODAWAYCO	161.0	1	153	147.4	147.7	4.8%	S1399 to Humboldt	XS300071>300692>\$3
635034	CLRND 5	161.0	560001	NODAWAYCO	161.0	1	153	147.4	147.7	4.8%	S1399 to Humboldt	XS300061>300501>\$1
635034	CLRND 5	161.0	560001	NODAWAYCO	161.0	1	153	147.4	147.7	4.8%	S1399 to Humboldt	XS300075>345790>\$1
635034	CLRND 5	161.0	560001	NODAWAYCO	161.0	1	153	147.4	147.7	4.8%	S1399 to Humboldt	XS300089>300673>\$2
635034	CLRND 5	161.0	560001	NODAWAYCO	161.0	1	153	147.3	147.7	4.8%	S1399 to Humboldt	XS300095>301057>\$1
635034	CLRND 5	161.0	560001	NODAWAYCO	161.0	1	153	147.4	147.7	4.8%	S1399 to Humboldt	XS300093>301212>\$2
635034	CLRND 5	161.0	560001	NODAWAYCO	161.0	1	153	147.4	147.7	4.8%	S1399 to Humboldt	XS300093>301212>\$1
635034	CLRND 5	161.0	560001	NODAWAYCO	161.0	1	153	147.4	147.7	4.8%	S1399 to Humboldt	XS300072>300088>\$1
635034	CLRND 5	161.0	560001	NODAWAYCO	161.0	1	153	147.4	147.7	4.8%	S1399 to Humboldt	XS300094>300278>\$1
635034	CLRND 5	161.0	560001	NODAWAYCO	161.0	1	153	147.4	147.7	4.8%	S1399 to Humboldt	XS300061>300493>\$1
635034	CLRND 5	161.0	560001	NODAWAYCO	161.0	1	153	147.4	147.7	4.8%	S1399 to Humboldt	XS300078>300096>\$2
635034	CLRND 5	161.0	560001	NODAWAYCO	161.0	1	153	147.4	147.7	4.8%	S1399 to Humboldt	XS300079>301283>\$1
635034	CLRND 5	161.0	560001	NODAWAYCO	161.0	1	153	147.4	147.7	4.8%	S1399 to Humboldt	XS300081>301090>\$1
635034	CLRND 5	161.0	560001	NODAWAYCO	161.0	1	153	147.4	147.7	4.8%	S1399 to Humboldt	XS300101>300782>\$1
635034	CLRND 5	161.0	560001	NODAWAYCO	161.0	1	153	147.3	147.7	4.8%	S1399 to Humboldt	XS300040>300077>300175\$1
635034	CLRND 5	161.0	560001	NODAWAYCO	161.0	1	153	147.4	147.7	4.8%	S1399 to Humboldt	S1217 AUTOV2
635034	CLRND 5	161.0	560001	NODAWAYCO	161.0	1	153	147.4	147.7	4.8%	S1399 to Humboldt	XS300066>300508>\$1
635034	CLRND 5	161.0	560001	NODAWAYCO	161.0	1	153	147.3	147.7	4.8%	S1399 to Humboldt	XS300083>300103>\$1
635034	CLRND 5	161.0	560001	NODAWAYCO	161.0	1	153	147.4	147.7	4.8%	S1399 to Humboldt	XS300067>300119>\$1
635034	CLRND 5	161.0	560001	NODAWAYCO	161.0	1	153	147.4	147.7	4.8%	S1399 to Humboldt	XS300078>300096>\$1
635034	CLRND 5	161.0	560001	NODAWAYCO	161.0	1	153	147.4	147.7	4.8%	S1399 to Humboldt	XS300041>300047>\$1
635034	CLRND 5	161.0	560001	NODAWAYCO	161.0	1	153	147.4	147.7	4.8%	S1399 to Humboldt	XS300082>300531>\$1
635034	CLRND 5	161.0	560001	NODAWAYCO	161.0	1	153	147.4	147.7	4.8%	S1399 to Humboldt	XS300043>300090>\$1
635034	CLRND 5	161.0	560001	NODAWAYCO	161.0	1	153	147.4	147.7	4.8%	S1399 to Humboldt	XS300079>345976>\$1
635034	CLRND 5	161.0	560001	NODAWAYCO	161.0	1	153	147.4	147.7	4.8%	S1399 to Humboldt	XS300080>301188>\$1
635034	CLRND 5	161.0	560001	NODAWAYCO	161.0	1	153	147.3	147.7	4.8%	S1399 to Humboldt	XS300080>301015>\$1
635034	CLRND 5	161.0	560001	NODAWAYCO	161.0	1	153	147.4	147.7	4.8%	S1399 to Humboldt	XS300068>300194>\$2

635034	CLRND 5	161.0	560001	NODAWAYCO	161.0	1	153	147.3	147.7	4.8%	S1399 to Humboldt	XS300081>300095>\$1
635034	CLRND 5	161.0	560001	NODAWAYCO	161.0	1	153	147.4	147.7	4.8%	S1399 to Humboldt	XS300079>301283>\$2
635034	CLRND 5	161.0	560001	NODAWAYCO	161.0	1	153	147.4	147.7	4.8%	S1399 to Humboldt	MCFTCAL5
635034	CLRND 5	161.0	560001	NODAWAYCO	161.0	1	153	147.4	147.7	4.8%	S1399 to Humboldt	XS300080>301188>\$2
635034	CLRND 5	161.0	560001	NODAWAYCO	161.0	1	153	147.4	147.7	4.8%	S1399 to Humboldt	XS300101>547478>\$1
635034	CLRND 5	161.0	560001	NODAWAYCO	161.0	1	153	147.4	147.7	4.8%	S1399 to Humboldt	XS300067>300626>\$1
635034	CLRND 5	161.0	560001	NODAWAYCO	161.0	1	153	147.4	147.7	4.8%	S1399 to Humboldt	XS300043>300044>\$1
635034	CLRND 5	161.0	560001	NODAWAYCO	161.0	1	153	147.4	147.7	4.8%	S1399 to Humboldt	XS300077>344566>\$1
635034	CLRND 5	161.0	560001	NODAWAYCO	161.0	1	153	147.4	147.7	4.8%	S1399 to Humboldt	XS300055>300060>\$1
635034	CLRND 5	161.0	560001	NODAWAYCO	161.0	1	153	147.3	147.7	4.8%	S1399 to Humboldt	XS300085>300086>\$1
635034	CLRND 5	161.0	560001	NODAWAYCO	161.0	1	153	147.4	147.7	4.8%	S1399 to Humboldt	S1210 AUTOV2
635034	CLRND 5	161.0	560001	NODAWAYCO	161.0	1	153	147.4	147.7	4.8%	S1399 to Humboldt	XS300038>300046>\$1
635034	CLRND 5	161.0	560001	NODAWAYCO	161.0	1	153	147.4	147.7	4.8%	S1399 to Humboldt	XS300037>300606>\$1
635034	CLRND 5	161.0	560001	NODAWAYCO	161.0	1	153	147.3	147.7	4.8%	S1399 to Humboldt	XS300069>300741>\$1
635034	CLRND 5	161.0	560001	NODAWAYCO	161.0	1	153	147.3	147.7	4.8%	S1399 to Humboldt	XS300038>300075>\$1
635034	CLRND 5	161.0	560001	NODAWAYCO	161.0	1	153	147.4	147.7	4.8%	S1399 to Humboldt	XS300077>300093>\$1
635034	CLRND 5	161.0	560001	NODAWAYCO	161.0	1	153	147.4	147.7	4.8%	S1399 to Humboldt	XS300083>338202>\$1
635034	CLRND 5	161.0	560001	NODAWAYCO	161.0	1	153	147.4	147.7	4.8%	S1399 to Humboldt	XS300066>300126>\$1
635034	CLRND 5	161.0	560001	NODAWAYCO	161.0	1	153	147.4	147.7	4.8%	S1399 to Humboldt	XS300070>300793>\$1
635034	CLRND 5	161.0	560001	NODAWAYCO	161.0	1	153	147.4	147.7	4.8%	S1399 to Humboldt	XS300066>300120>\$1
635034	CLRND 5	161.0	560001	NODAWAYCO	161.0	1	153	147.4	147.7	4.8%	S1399 to Humboldt	XS300083>301291>\$1
635034	CLRND 5	161.0	560001	NODAWAYCO	161.0	1	153	147.3	147.7	4.8%	S1399 to Humboldt	XS300085>300777>\$1
635034	CLRND 5	161.0	560001	NODAWAYCO	161.0	1	153	147.4	147.7	4.8%	S1399 to Humboldt	XS300794>300651>\$1
635034	CLRND 5	161.0	560001	NODAWAYCO	161.0	1	153	147.3	147.7	4.8%	S1399 to Humboldt	XS532873>533381>532897\$1
635034	CLRND 5	161.0	560001	NODAWAYCO	161.0	1	153	147.4	147.7	4.8%	S1399 to Humboldt	XS300500>345409>\$1
635034	CLRND 5	161.0	560001	NODAWAYCO	161.0	1	153	147.4	147.7	4.8%	S1399 to Humboldt	XS300115>338202>\$1
635034	CLRND 5	161.0	560001	NODAWAYCO	161.0	1	153	147.4	147.7	4.8%	S1399 to Humboldt	XS300140>300943>\$2

635034	CLRND 5	161.0	560001	NODAWAYCO	161.0	1	153	147.4	147.7	4.8%	S1399 to Humboldt	XS300795>512707>\$1
635034	CLRND 5	161.0	560001	NODAWAYCO	161.0	1	153	147.4	147.7	4.8%	S1399 to Humboldt	XS300500>343004>\$1
635034	CLRND 5	161.0	560001	NODAWAYCO	161.0	1	153	147.4	147.7	4.8%	S1399 to Humboldt	XS300795>510396>\$1
635034	CLRND 5	161.0	560001	NODAWAYCO	161.0	1	153	147.4	147.7	4.8%	S1399 to Humboldt	XS300129>505486>\$1
635034	CLRND 5	161.0	560001	NODAWAYCO	161.0	1	153	147.4	147.7	4.8%	S1399 to Humboldt	XS300119>301152>\$1
635034	CLRND 5	161.0	560001	NODAWAYCO	161.0	1	153	147.4	147.7	4.8%	S1399 to Humboldt	XS532766>532852>532805\$1
635034	CLRND 5	161.0	560001	NODAWAYCO	161.0	1	153	147.4	147.7	4.8%	S1399 to Humboldt	XS300119>301136>\$1
635034	CLRND 5	161.0	560001	NODAWAYCO	161.0	1	153	147.3	147.7	4.8%	S1399 to Humboldt	XS300118>300793>\$1
635034	CLRND 5	161.0	560001	NODAWAYCO	161.0	1	153	147.4	147.7	4.8%	S1399 to Humboldt	XS300140>300943>\$1
635034	CLRND 5	161.0	560001	NODAWAYCO	161.0	1	153	147.3	147.7	4.8%	S1399 to Humboldt	XS300140>300141>\$1
635034	CLRND 5	161.0	560001	NODAWAYCO	161.0	1	153	147.3	147.7	4.8%	S1399 to Humboldt	XS300501>343015>\$1
635034	CLRND 5	161.0	560001	NODAWAYCO	161.0	1	153	147.3	147.7	4.8%	S1399 to Humboldt	XS532873>533381>532896\$1
635034	CLRND 5	161.0	560001	NODAWAYCO	161.0	1	153	147.3	147.7	4.8%	S1399 to Humboldt	XS300119>300142>\$1
635034	CLRND 5	161.0	560001	NODAWAYCO	161.0	1	153	147.4	147.7	4.8%	S1399 to Humboldt	XS300141>300845>\$1
635034	CLRND 5	161.0	560001	NODAWAYCO	161.0	1	153	147.4	147.7	4.8%	S1399 to Humboldt	XS532937>547469>\$1
635034	CLRND 5	161.0	560001	NODAWAYCO	161.0	1	153	147.4	147.7	4.8%	S1399 to Humboldt	XS300832>301159>\$1
635034	CLRND 5	161.0	560001	NODAWAYCO	161.0	1	153	147.3	147.7	4.8%	S1399 to Humboldt	XS300135>300856>\$1
635034	CLRND 5	161.0	560001	NODAWAYCO	161.0	1	153	147.4	147.7	4.8%	S1399 to Humboldt	XS300600>300608>\$1
635034	CLRND 5	161.0	560001	NODAWAYCO	161.0	1	153	147.4	147.7	4.8%	S1399 to Humboldt	XS300129>505480>\$1
635034	CLRND 5	161.0	560001	NODAWAYCO	161.0	1	153	147.4	147.7	4.8%	S1399 to Humboldt	XS300832>301165>\$1
635034	CLRND 5	161.0	560001	NODAWAYCO	161.0	1	153	147.3	147.7	4.8%	S1399 to Humboldt	XS300113>300349>\$1
635034	CLRND 5	161.0	560001	NODAWAYCO	161.0	1	153	147.4	147.7	4.8%	S1399 to Humboldt	XS300112>301027>\$2
635034	CLRND 5	161.0	560001	NODAWAYCO	161.0	1	153	147.3	147.7	4.8%	S1399 to Humboldt	XS532780>532800>\$1
635034	CLRND 5	161.0	560001	NODAWAYCO	161.0	1	153	147.4	147.7	4.8%	S1399 to Humboldt	XS300112>301027>\$1
635034	CLRND 5	161.0	560001	NODAWAYCO	161.0	1	153	147.3	147.7	4.8%	S1399 to Humboldt	XS532794>533062>532826\$1
635034	CLRND 5	161.0	560001	NODAWAYCO	161.0	1	153	147.3	147.7	4.8%	S1399 to Humboldt	XS300123>301123>\$2
635034	CLRND 5	161.0	560001	NODAWAYCO	161.0	1	153	147.4	147.7	4.8%	S1399 to Humboldt	XS300119>301152>\$2

635034	CLRND 5	161.0	560001	NODAWAYCO	161.0	1	153	147.4	147.7	4.8%	S1399 to Humboldt	XS300805>547621>\$1
635034	CLRND 5	161.0	560001	NODAWAYCO	161.0	1	153	147.3	147.7	4.8%	S1399 to Humboldt	XS532851>533151>532880\$1
635034	CLRND 5	161.0	560001	NODAWAYCO	161.0	1	153	147.3	147.7	4.8%	S1399 to Humboldt	XS300140>509757>\$1
635034	CLRND 5	161.0	560001	NODAWAYCO	161.0	1	153	147.4	147.7	4.8%	S1399 to Humboldt	XS300141>300844>\$1
635034	CLRND 5	161.0	560001	NODAWAYCO	161.0	1	153	147.3	147.7	4.8%	S1399 to Humboldt	XS300113>300349>\$2
635034	CLRND 5	161.0	560001	NODAWAYCO	161.0	1	153	147.4	147.7	4.8%	S1399 to Humboldt	XS300102>301163>\$1
635034	CLRND 5	161.0	560001	NODAWAYCO	161.0	1	153	147.4	147.7	4.8%	S1399 to Humboldt	XS300793>300798>\$1
635034	CLRND 5	161.0	560001	NODAWAYCO	161.0	1	153	147.3	147.7	4.8%	S1399 to Humboldt	XS300596>300602>\$1
635034	CLRND 5	161.0	560001	NODAWAYCO	161.0	1	153	147.3	147.7	4.8%	S1399 to Humboldt	XS532794>533062>532827\$1
635034	CLRND 5	161.0	560001	NODAWAYCO	161.0	1	153	147.4	147.7	4.8%	S1399 to Humboldt	XS532780>532793>\$1
635034	CLRND 5	161.0	560001	NODAWAYCO	161.0	1	153	147.3	147.7	4.8%	S1399 to Humboldt	XS300122>300123>\$1
635034	CLRND 5	161.0	560001	NODAWAYCO	161.0	1	153	147.4	147.7	4.8%	S1399 to Humboldt	XS300501>345071>\$1
635034	CLRND 5	161.0	560001	NODAWAYCO	161.0	1	153	147.4	147.7	4.8%	S1399 to Humboldt	XS300137>300889>\$1
635034	CLRND 5	161.0	560001	NODAWAYCO	161.0	1	153	147.4	147.7	4.8%	S1399 to Humboldt	XS300719>300727>\$1
635034	CLRND 5	161.0	560001	NODAWAYCO	161.0	1	153	147.4	147.7	4.8%	S1399 to Humboldt	XS532863>533305>532890\$1
635034	CLRND 5	161.0	560001	NODAWAYCO	161.0	1	153	147.3	147.7	4.8%	S1399 to Humboldt	XS300719>505472>\$1
635034	CLRND 5	161.0	560001	NODAWAYCO	161.0	1	153	147.4	147.7	4.8%	S1399 to Humboldt	XS300563>300566>\$1
635034	CLRND 5	161.0	560001	NODAWAYCO	161.0	1	153	147.3	147.7	4.8%	S1399 to Humboldt	XS300593>344773>\$1
635034	CLRND 5	161.0	560001	NODAWAYCO	161.0	1	153	147.4	147.7	4.8%	S1399 to Humboldt	XS300137>300889>\$2
635034	CLRND 5	161.0	560001	NODAWAYCO	161.0	1	153	147.3	147.7	4.8%	S1399 to Humboldt	XS300123>301123>\$1
635034	CLRND 5	161.0	560001	NODAWAYCO	161.0	1	153	147.4	147.7	4.8%	S1399 to Humboldt	XS532768>532770>\$1
635034	CLRND 5	161.0	560001	NODAWAYCO	161.0	1	153	147.4	147.7	4.8%	S1399 to Humboldt	XS300121>345375>\$1
635034	CLRND 5	161.0	560001	NODAWAYCO	161.0	1	153	147.4	147.7	4.8%	S1399 to Humboldt	XS532862>532863>\$1
635034	CLRND 5	161.0	560001	NODAWAYCO	161.0	1	153	147.4	147.7	4.8%	S1399 to Humboldt	XS532862>533335>532898\$1
635034	CLRND 5	161.0	560001	NODAWAYCO	161.0	1	153	147.4	147.7	4.8%	S1399 to Humboldt	XS532768>532769>\$1
635034	CLRND 5	161.0	560001	NODAWAYCO	161.0	1	153	147.4	147.7	4.8%	S1399 to Humboldt	XS300756>300769>\$1
635034	CLRND 5	161.0	560001	NODAWAYCO	161.0	1	153	147.4	147.7	4.8%	S1399 to Humboldt	XS532856>532863>\$1

635034	CLRND 5	161.0	560001	NODAWAYCO	161.0	1	153	147.4	147.7	4.8%	S1399 to Humboldt	XS300120>300126>\$1
635034	CLRND 5	161.0	560001	NODAWAYCO	161.0	1	153	147.3	147.7	4.8%	S1399 to Humboldt	XS300138>512694>512817\$1
635034	CLRND 5	161.0	560001	NODAWAYCO	161.0	1	153	147.3	147.7	4.8%	S1399 to Humboldt	XS532851>532856>\$1
635034	CLRND 5	161.0	560001	NODAWAYCO	161.0	1	153	147.4	147.7	4.8%	S1399 to Humboldt	XS300508>300505>\$1
635034	CLRND 5	161.0	560001	NODAWAYCO	161.0	1	153	147.4	147.7	4.8%	S1399 to Humboldt	XS532769>533304>532808\$1
635034	CLRND 5	161.0	560001	NODAWAYCO	161.0	1	153	147.4	147.7	4.8%	S1399 to Humboldt	XS300756>338804>\$1
635034	CLRND 5	161.0	560001	NODAWAYCO	161.0	1	153	147.4	147.7	4.8%	S1399 to Humboldt	XS532766>532852>532806\$1
635034	CLRND 5	161.0	560001	NODAWAYCO	161.0	1	153	147.4	147.7	4.8%	S1399 to Humboldt	XS300606>344480>\$1
635034	CLRND 5	161.0	560001	NODAWAYCO	161.0	1	153	147.4	147.7	4.8%	S1399 to Humboldt	XS300124>300336>\$1
635034	CLRND 5	161.0	560001	NODAWAYCO	161.0	1	153	147.4	147.7	4.8%	S1399 to Humboldt	XS532772>541231>532812\$1
635034	CLRND 5	161.0	560001	NODAWAYCO	161.0	1	153	147.4	147.7	4.8%	S1399 to Humboldt	XS300121>301255>\$1
635034	CLRND 5	161.0	560001	NODAWAYCO	161.0	1	153	147.4	147.7	4.8%	S1399 to Humboldt	XS300740>300741>\$1
635034	CLRND 5	161.0	560001	NODAWAYCO	161.0	1	153	147.4	147.7	4.8%	S1399 to Humboldt	XS300138>300927>\$2
635034	CLRND 5	161.0	560001	NODAWAYCO	161.0	1	153	147.3	147.7	4.8%	S1399 to Humboldt	XS300120>300172>\$1
635034	CLRND 5	161.0	560001	NODAWAYCO	161.0	1	153	147.4	147.7	4.8%	S1399 to Humboldt	XS300508>300505>\$2
635034	CLRND 5	161.0	560001	NODAWAYCO	161.0	1	153	147.4	147.7	4.8%	S1399 to Humboldt	XS300740>300741>\$2
635034	CLRND 5	161.0	560001	NODAWAYCO	161.0	1	153	147.4	147.7	4.8%	S1399 to Humboldt	XS532871>532872>\$1
635034	CLRND 5	161.0	560001	NODAWAYCO	161.0	1	153	147.3	147.7	4.8%	S1399 to Humboldt	XS300740>512650>\$1
635034	CLRND 5	161.0	560001	NODAWAYCO	161.0	1	153	147.3	147.7	4.8%	S1399 to Humboldt	XS300120>300172>\$2
635034	CLRND 5	161.0	560001	NODAWAYCO	161.0	1	153	147.4	147.7	4.8%	S1399 to Humboldt	XS300138>300927>\$1
635034	CLRND 5	161.0	560001	NODAWAYCO	161.0	1	153	147.4	147.7	4.8%	S1399 to Humboldt	XS532791>532796>\$1
635034	CLRND 5	161.0	560001	NODAWAYCO	161.0	1	153	147.4	147.7	4.8%	S1399 to Humboldt	XS300993>512638>\$1
635034	CLRND 5	161.0	560001	NODAWAYCO	161.0	1	153	147.4	147.7	4.8%	S1399 to Humboldt	XS532853>532856>\$1
635034	CLRND 5	161.0	560001	NODAWAYCO	161.0	1	153	147.3	147.7	4.8%	S1399 to Humboldt	XS301161>549970>\$1
635034	CLRND 5	161.0	560001	NODAWAYCO	161.0	1	153	147.4	147.7	4.8%	S1399 to Humboldt	XS300103>505428>\$1
635034	CLRND 5	161.0	560001	NODAWAYCO	161.0	1	153	147.4	147.7	4.8%	S1399 to Humboldt	XS532932>533765>532952\$1
635034	CLRND 5	161.0	560001	NODAWAYCO	161.0	1	153	147.4	147.7	4.8%	S1399 to Humboldt	XS532793>532937>532825\$1

635034	CLRND 5	161.0	560001	NODAWAYCO	161.0	1	153	147.4	147.7	4.8%	S1399 to Humboldt	XS300145>300931>\$1
635034	CLRND 5	161.0	560001	NODAWAYCO	161.0	1	153	147.4	147.7	4.8%	S1399 to Humboldt	XS301347>301356>\$2
635034	CLRND 5	161.0	560001	NODAWAYCO	161.0	1	153	147.4	147.7	4.8%	S1399 to Humboldt	XS300993>512627>\$1
635034	CLRND 5	161.0	560001	NODAWAYCO	161.0	1	153	147.4	147.7	4.8%	S1399 to Humboldt	XS300146>301339>\$1
635034	CLRND 5	161.0	560001	NODAWAYCO	161.0	1	153	147.4	147.7	4.8%	S1399 to Humboldt	XS300597>345544>\$1
635034	CLRND 5	161.0	560001	NODAWAYCO	161.0	1	153	147.4	147.7	4.8%	S1399 to Humboldt	XS300165>301339>\$1
635034	CLRND 5	161.0	560001	NODAWAYCO	161.0	1	153	147.4	147.7	4.8%	S1399 to Humboldt	XS300108>300811>\$1
635034	CLRND 5	161.0	560001	NODAWAYCO	161.0	1	153	147.4	147.7	4.8%	S1399 to Humboldt	XS300146>512705>\$1
635034	CLRND 5	161.0	560001	NODAWAYCO	161.0	1	153	147.4	147.7	4.8%	S1399 to Humboldt	XS300103>505400>\$1
635034	CLRND 5	161.0	560001	NODAWAYCO	161.0	1	153	147.4	147.7	4.8%	S1399 to Humboldt	XS300106>344001>\$1
635034	CLRND 5	161.0	560001	NODAWAYCO	161.0	1	153	147.4	147.7	4.8%	S1399 to Humboldt	XS300143>300850>\$1
635034	CLRND 5	161.0	560001	NODAWAYCO	161.0	1	153	147.4	147.7	4.8%	S1399 to Humboldt	XS300997>512627>\$1
635034	CLRND 5	161.0	560001	NODAWAYCO	161.0	1	153	147.4	147.7	4.8%	S1399 to Humboldt	XS532793>533021>532824\$1
635034	CLRND 5	161.0	560001	NODAWAYCO	161.0	1	153	147.4	147.7	4.8%	S1399 to Humboldt	XS300105>300540>\$1
635034	CLRND 5	161.0	560001	NODAWAYCO	161.0	1	153	147.4	147.7	4.8%	S1399 to Humboldt	XS300997>512651>\$1
635034	CLRND 5	161.0	560001	NODAWAYCO	161.0	1	153	147.4	147.7	4.8%	S1399 to Humboldt	XS300106>300363>\$1
635034	CLRND 5	161.0	560001	NODAWAYCO	161.0	1	153	147.4	147.7	4.8%	S1399 to Humboldt	XS532771>533416>532807\$1
635034	CLRND 5	161.0	560001	NODAWAYCO	161.0	1	153	147.4	147.7	4.8%	S1399 to Humboldt	XS300596>344773>\$1
635034	CLRND 5	161.0	560001	NODAWAYCO	161.0	1	153	147.3	147.7	4.8%	S1399 to Humboldt	XS300597>345543>\$1
635034	CLRND 5	161.0	560001	NODAWAYCO	161.0	1	153	147.3	147.7	4.8%	S1399 to Humboldt	XS301057>301070>\$1
635034	CLRND 5	161.0	560001	NODAWAYCO	161.0	1	153	147.4	147.7	4.8%	S1399 to Humboldt	XS301307>512655>\$1
635034	CLRND 5	161.0	560001	NODAWAYCO	161.0	1	153	147.4	147.7	4.8%	S1399 to Humboldt	XS300146>512649>\$1
635034	CLRND 5	161.0	560001	NODAWAYCO	161.0	1	153	147.4	147.7	4.8%	S1399 to Humboldt	XS532934>533639>532955\$1
635034	CLRND 5	161.0	560001	NODAWAYCO	161.0	1	153	147.4	147.7	4.8%	S1399 to Humboldt	XS300131>300145>\$1
635034	CLRND 5	161.0	560001	NODAWAYCO	161.0	1	153	147.4	147.7	4.8%	S1399 to Humboldt	XS301144>301154>\$1
635034	CLRND 5	161.0	560001	NODAWAYCO	161.0	1	153	147.4	147.7	4.8%	S1399 to Humboldt	XS300141>300845>\$2
635034	CLRND 5	161.0	560001	NODAWAYCO	161.0	1	153	147.4	147.7	4.8%	S1399 to Humboldt	XS301347>301356>\$1

635034	CLRNDA 5	161.0	560001	NODAWAYCO	161.0	1	153	147.4	147.7	4.8%	S1399 to Humboldt	XS300165>300948>\$1
635034	CLRNDA 5	161.0	560001	NODAWAYCO	161.0	1	153	147.4	147.7	4.8%	S1399 to Humboldt	XS532932>533765>532953\$1
635034	CLRNDA 5	161.0	560001	NODAWAYCO	161.0	1	153	147.4	147.7	4.8%	S1399 to Humboldt	XS301059>301062>\$1
635034	CLRNDA 5	161.0	560001	NODAWAYCO	161.0	1	153	147.4	147.7	4.8%	S1399 to Humboldt	XS300107>300290>\$1
635034	CLRNDA 5	161.0	560001	NODAWAYCO	161.0	1	153	147.3	147.7	4.8%	S1399 to Humboldt	XS300106>300364>\$1
635034	CLRNDA 5	161.0	560001	NODAWAYCO	161.0	1	153	147.4	147.7	4.8%	S1399 to Humboldt	XS300130>300738>\$1
635034	CLRNDA 5	161.0	560001	NODAWAYCO	161.0	1	153	147.4	147.7	4.8%	S1399 to Humboldt	XS301124>338215>\$1
635034	CLRNDA 5	161.0	560001	NODAWAYCO	161.0	1	153	147.3	147.7	4.8%	S1399 to Humboldt	XS300103>338201>\$1
635034	CLRNDA 5	161.0	560001	NODAWAYCO	161.0	1	153	147.3	147.7	4.8%	S1399 to Humboldt	XS300142>301144>\$1
635034	CLRNDA 5	161.0	560001	NODAWAYCO	161.0	1	153	147.4	147.7	4.8%	S1399 to Humboldt	XS300130>300727>\$1
635034	CLRNDA 5	161.0	560001	NODAWAYCO	161.0	1	153	147.4	147.7	4.8%	S1399 to Humboldt	XS300867>300869>\$1
635034	CLRNDA 5	161.0	560001	NODAWAYCO	161.0	1	153	147.4	147.7	4.8%	S1399 to Humboldt	XS300858>300881>\$1
635034	CLRNDA 5	161.0	560001	NODAWAYCO	161.0	1	153	147.3	147.7	4.8%	S1399 to Humboldt	XS300135>300136>\$1
635034	CLRNDA 5	161.0	560001	NODAWAYCO	161.0	1	153	147.4	147.7	4.8%	S1399 to Humboldt	XS300110>300331>\$1
635034	CLRNDA 5	161.0	560001	NODAWAYCO	161.0	1	153	147.3	147.7	4.8%	S1399 to Humboldt	XS301128>301171>\$1
635034	CLRNDA 5	161.0	560001	NODAWAYCO	161.0	1	153	147.3	147.7	4.8%	S1399 to Humboldt	XS532791>532794>\$1
635034	CLRNDA 5	161.0	560001	NODAWAYCO	161.0	1	153	147.4	147.7	4.8%	S1399 to Humboldt	XS300111>300636>\$1
635034	CLRNDA 5	161.0	560001	NODAWAYCO	161.0	1	153	147.4	147.7	4.8%	S1399 to Humboldt	XS300141>512731>\$1
635034	CLRNDA 5	161.0	560001	NODAWAYCO	161.0	1	153	147.4	147.7	4.8%	S1399 to Humboldt	XS300102>301163>\$2
635034	CLRNDA 5	161.0	560001	NODAWAYCO	161.0	1	153	147.4	147.7	4.8%	S1399 to Humboldt	XS300143>300844>\$1
635034	CLRNDA 5	161.0	560001	NODAWAYCO	161.0	1	153	147.3	147.7	4.8%	S1399 to Humboldt	XS300597>300602>\$1
635034	CLRNDA 5	161.0	560001	NODAWAYCO	161.0	1	153	147.4	147.7	4.8%	S1399 to Humboldt	XS301159>549968>\$1
635034	CLRNDA 5	161.0	560001	NODAWAYCO	161.0	1	153	147.3	147.7	4.8%	S1399 to Humboldt	XS300112>301015>\$1
635034	CLRNDA 5	161.0	560001	NODAWAYCO	161.0	1	153	147.4	147.7	4.8%	S1399 to Humboldt	XS300131>505610>\$1
635034	CLRNDA 5	161.0	560001	NODAWAYCO	161.0	1	153	147.4	147.7	4.8%	S1399 to Humboldt	XS300167>300597>\$1
635034	CLRNDA 5	161.0	560001	NODAWAYCO	161.0	1	153	147.3	147.7	4.8%	S1399 to Humboldt	XS300134>300593>\$1
635034	CLRNDA 5	161.0	560001	NODAWAYCO	161.0	1	153	147.4	147.7	4.8%	S1399 to Humboldt	XS300167>300606>\$1

635034	CLRNDA 5	161.0	560001	NODAWAYCO	161.0	1	153	147.4	147.7	4.8%	S1399 to Humboldt	XS533172>533184>\$1
635034	CLRNDA 5	161.0	560001	NODAWAYCO	161.0	1	153	147.4	147.7	4.8%	S1399 to Humboldt	XS533337>533348>\$1
635034	CLRNDA 5	161.0	560001	NODAWAYCO	161.0	1	153	147.3	147.7	4.8%	S1399 to Humboldt	XS532996>533001>\$1
635034	CLRNDA 5	161.0	560001	NODAWAYCO	161.0	1	153	147.4	147.7	4.8%	S1399 to Humboldt	XS533255>533273>\$1
635034	CLRNDA 5	161.0	560001	NODAWAYCO	161.0	1	153	147.3	147.7	4.8%	S1399 to Humboldt	XS533030>533068>\$1
635034	CLRNDA 5	161.0	560001	NODAWAYCO	161.0	1	153	147.4	147.7	4.8%	S1399 to Humboldt	XS533241>533264>\$1
635034	CLRNDA 5	161.0	560001	NODAWAYCO	161.0	1	153	147.4	147.7	4.8%	S1399 to Humboldt	XS532992>533558>533120\$1
635034	CLRNDA 5	161.0	560001	NODAWAYCO	161.0	1	153	147.4	147.7	4.8%	S1399 to Humboldt	XS533281>533283>\$1
635034	CLRNDA 5	161.0	560001	NODAWAYCO	161.0	1	153	147.4	147.7	4.8%	S1399 to Humboldt	XS533011>533736>533093\$1
635034	CLRNDA 5	161.0	560001	NODAWAYCO	161.0	1	153	147.3	147.7	4.8%	S1399 to Humboldt	XS533035>533786>533103\$1
635034	CLRNDA 5	161.0	560001	NODAWAYCO	161.0	1	153	147.4	147.7	4.8%	S1399 to Humboldt	XS533156>533198>\$1
635034	CLRNDA 5	161.0	560001	NODAWAYCO	161.0	1	153	147.3	147.7	4.8%	S1399 to Humboldt	XS533341>533345>\$1
635034	CLRNDA 5	161.0	560001	NODAWAYCO	161.0	1	153	147.4	147.7	4.8%	S1399 to Humboldt	XS532991>533604>533083\$1
635034	CLRNDA 5	161.0	560001	NODAWAYCO	161.0	1	153	147.4	147.7	4.8%	S1399 to Humboldt	XS533232>533250>\$1
635034	CLRNDA 5	161.0	560001	NODAWAYCO	161.0	1	153	147.4	147.7	4.8%	S1399 to Humboldt	XS533172>533177>\$1
635034	CLRNDA 5	161.0	560001	NODAWAYCO	161.0	1	153	147.4	147.7	4.8%	S1399 to Humboldt	XS533257>533280>\$1
635034	CLRNDA 5	161.0	560001	NODAWAYCO	161.0	1	153	147.4	147.7	4.8%	S1399 to Humboldt	XS533342>533343>\$1
635034	CLRNDA 5	161.0	560001	NODAWAYCO	161.0	1	153	147.4	147.7	4.8%	S1399 to Humboldt	XS533232>533271>\$1
635034	CLRNDA 5	161.0	560001	NODAWAYCO	161.0	1	153	147.3	147.7	4.8%	S1399 to Humboldt	XS533171>533306>\$1
635034	CLRNDA 5	161.0	560001	NODAWAYCO	161.0	1	153	147.4	147.7	4.8%	S1399 to Humboldt	XS533368>533381>\$1
635034	CLRNDA 5	161.0	560001	NODAWAYCO	161.0	1	153	147.4	147.7	4.8%	S1399 to Humboldt	XS532986>533035>\$1
635034	CLRNDA 5	161.0	560001	NODAWAYCO	161.0	1	153	147.3	147.7	4.8%	S1399 to Humboldt	XS533040>533065>\$1
635034	CLRNDA 5	161.0	560001	NODAWAYCO	161.0	1	153	147.4	147.7	4.8%	S1399 to Humboldt	XS533001>533006>\$1
635034	CLRNDA 5	161.0	560001	NODAWAYCO	161.0	1	153	147.4	147.7	4.8%	S1399 to Humboldt	XS533243>533261>\$1
635034	CLRNDA 5	161.0	560001	NODAWAYCO	161.0	1	153	147.4	147.7	4.8%	S1399 to Humboldt	XS533372>533373>\$1
635034	CLRNDA 5	161.0	560001	NODAWAYCO	161.0	1	153	147.4	147.7	4.8%	S1399 to Humboldt	XS533040>533054>\$1
635034	CLRNDA 5	161.0	560001	NODAWAYCO	161.0	1	153	147.4	147.7	4.8%	S1399 to Humboldt	XS533333>533347>\$1

635034	CLRNDA 5	161.0	560001	NODAWAYCO	161.0	1	153	147.4	147.7	4.8%	S1399 to Humboldt	XS533178>533179>\$1
635034	CLRNDA 5	161.0	560001	NODAWAYCO	161.0	1	153	147.3	147.7	4.8%	S1399 to Humboldt	XS533253>533271>\$1
635034	CLRNDA 5	161.0	560001	NODAWAYCO	161.0	1	153	147.4	147.7	4.8%	S1399 to Humboldt	XS533218>533220>\$1
635034	CLRNDA 5	161.0	560001	NODAWAYCO	161.0	1	153	147.4	147.7	4.8%	S1399 to Humboldt	XS533001>533005>\$1
635034	CLRNDA 5	161.0	560001	NODAWAYCO	161.0	1	153	147.3	147.7	4.8%	S1399 to Humboldt	XS533304>533306>\$1
635034	CLRNDA 5	161.0	560001	NODAWAYCO	161.0	1	153	147.3	147.7	4.8%	S1399 to Humboldt	XS533219>533252>\$1
635034	CLRNDA 5	161.0	560001	NODAWAYCO	161.0	1	153	147.4	147.7	4.8%	S1399 to Humboldt	XS533177>533182>\$1
635034	CLRNDA 5	161.0	560001	NODAWAYCO	161.0	1	153	147.4	147.7	4.8%	S1399 to Humboldt	XS533242>533246>\$1
635034	CLRNDA 5	161.0	560001	NODAWAYCO	161.0	1	153	147.4	147.7	4.8%	S1399 to Humboldt	XS533013>533742>533095\$1
635034	CLRNDA 5	161.0	560001	NODAWAYCO	161.0	1	153	147.3	147.7	4.8%	S1399 to Humboldt	XS532986>532990>\$1
635034	CLRNDA 5	161.0	560001	NODAWAYCO	161.0	1	153	147.4	147.7	4.8%	S1399 to Humboldt	XS533030>533033>\$1
635034	CLRNDA 5	161.0	560001	NODAWAYCO	161.0	1	153	147.4	147.7	4.8%	S1399 to Humboldt	XS533219>533244>\$1
635034	CLRNDA 5	161.0	560001	NODAWAYCO	161.0	1	153	147.3	147.7	4.8%	S1399 to Humboldt	XS532996>533646>533084\$1
635034	CLRNDA 5	161.0	560001	NODAWAYCO	161.0	1	153	147.4	147.7	4.8%	S1399 to Humboldt	XS533335>533341>\$1
635034	CLRNDA 5	161.0	560001	NODAWAYCO	161.0	1	153	147.4	147.7	4.8%	S1399 to Humboldt	XS533176>533182>\$1
635034	CLRNDA 5	161.0	560001	NODAWAYCO	161.0	1	153	147.4	147.7	4.8%	S1399 to Humboldt	XS533171>533173>\$1
635034	CLRNDA 5	161.0	560001	NODAWAYCO	161.0	1	153	147.4	147.7	4.8%	S1399 to Humboldt	XS533236>533256>\$1
635034	CLRNDA 5	161.0	560001	NODAWAYCO	161.0	1	153	147.4	147.7	4.8%	S1399 to Humboldt	XS532991>533067>\$1
635034	CLRNDA 5	161.0	560001	NODAWAYCO	161.0	1	153	147.4	147.7	4.8%	S1399 to Humboldt	XS533160>533189>\$2
635034	CLRNDA 5	161.0	560001	NODAWAYCO	161.0	1	153	147.4	147.7	4.8%	S1399 to Humboldt	XS533236>533277>\$1
635034	CLRNDA 5	161.0	560001	NODAWAYCO	161.0	1	153	147.4	147.7	4.8%	S1399 to Humboldt	XS533034>533072>\$1
635034	CLRNDA 5	161.0	560001	NODAWAYCO	161.0	1	153	147.4	147.7	4.8%	S1399 to Humboldt	XS533266>533272>\$1
635034	CLRNDA 5	161.0	560001	NODAWAYCO	161.0	1	153	147.4	147.7	4.8%	S1399 to Humboldt	XS532990>533597>533082\$1
635034	CLRNDA 5	161.0	560001	NODAWAYCO	161.0	1	153	147.4	147.7	4.8%	S1399 to Humboldt	XS533362>533365>\$2
635034	CLRNDA 5	161.0	560001	NODAWAYCO	161.0	1	153	147.4	147.7	4.8%	S1399 to Humboldt	XS533234>533241>\$1
635034	CLRNDA 5	161.0	560001	NODAWAYCO	161.0	1	153	147.4	147.7	4.8%	S1399 to Humboldt	XS533163>533198>\$1
635034	CLRNDA 5	161.0	560001	NODAWAYCO	161.0	1	153	147.3	147.7	4.8%	S1399 to Humboldt	XS533262>533265>\$1

635034	CLRND 5	161.0	560001	NODAWAYCO	161.0	1	153	147.4	147.7	4.8%	S1399 to Humboldt	XS533362>533365>\$1
635034	CLRND 5	161.0	560001	NODAWAYCO	161.0	1	153	147.4	147.7	4.8%	S1399 to Humboldt	XS532987>533583>533118\$1
635034	CLRND 5	161.0	560001	NODAWAYCO	161.0	1	153	147.4	147.7	4.8%	S1399 to Humboldt	XS533044>533051>\$1
635034	CLRND 5	161.0	560001	NODAWAYCO	161.0	1	153	147.4	147.7	4.8%	S1399 to Humboldt	XS533034>533038>\$1
635034	CLRND 5	161.0	560001	NODAWAYCO	161.0	1	153	147.4	147.7	4.8%	S1399 to Humboldt	XS533163>533169>\$1
635034	CLRND 5	161.0	560001	NODAWAYCO	161.0	1	153	147.3	147.7	4.8%	S1399 to Humboldt	XS533262>533267>\$1
635034	CLRND 5	161.0	560001	NODAWAYCO	161.0	1	153	147.4	147.7	4.8%	S1399 to Humboldt	XS533162>533169>\$1
635034	CLRND 5	161.0	560001	NODAWAYCO	161.0	1	153	147.4	147.7	4.8%	S1399 to Humboldt	XS533033>533784>533101\$1
635034	CLRND 5	161.0	560001	NODAWAYCO	161.0	1	153	147.4	147.7	4.8%	S1399 to Humboldt	XS533011>533012>\$1
635034	CLRND 5	161.0	560001	NODAWAYCO	161.0	1	153	147.4	147.7	4.8%	S1399 to Humboldt	XS533271>533277>\$1
635034	CLRND 5	161.0	560001	NODAWAYCO	161.0	1	153	147.4	147.7	4.8%	S1399 to Humboldt	XS533041>533074>\$1
635034	CLRND 5	161.0	560001	NODAWAYCO	161.0	1	153	147.4	147.7	4.8%	S1399 to Humboldt	XS533233>533243>\$1
635034	CLRND 5	161.0	560001	NODAWAYCO	161.0	1	153	147.4	147.7	4.8%	S1399 to Humboldt	XS533368>533372>\$1
635034	CLRND 5	161.0	560001	NODAWAYCO	161.0	1	153	147.3	147.7	4.8%	S1399 to Humboldt	XS532991>533062>\$1
635034	CLRND 5	161.0	560001	NODAWAYCO	161.0	1	153	147.4	147.7	4.8%	S1399 to Humboldt	XS533344>533362>\$2
635034	CLRND 5	161.0	560001	NODAWAYCO	161.0	1	153	147.3	147.7	4.8%	S1399 to Humboldt	XS533015>533065>\$1
635034	CLRND 5	161.0	560001	NODAWAYCO	161.0	1	153	147.4	147.7	4.8%	S1399 to Humboldt	XS533233>533244>\$1
635034	CLRND 5	161.0	560001	NODAWAYCO	161.0	1	153	147.4	147.7	4.8%	S1399 to Humboldt	XS532987>532990>\$1
635034	CLRND 5	161.0	560001	NODAWAYCO	161.0	1	153	147.4	147.7	4.8%	S1399 to Humboldt	XS532987>532991>\$1
635034	CLRND 5	161.0	560001	NODAWAYCO	161.0	1	153	147.3	147.7	4.8%	S1399 to Humboldt	XS533012>533015>\$1
635034	CLRND 5	161.0	560001	NODAWAYCO	161.0	1	153	147.4	147.7	4.8%	S1399 to Humboldt	XS533035>533054>\$1
635034	CLRND 5	161.0	560001	NODAWAYCO	161.0	1	153	147.4	147.7	4.8%	S1399 to Humboldt	XS533042>533063>\$1
635034	CLRND 5	161.0	560001	NODAWAYCO	161.0	1	153	147.4	147.7	4.8%	S1399 to Humboldt	XS533012>533736>533092\$1
635034	CLRND 5	161.0	560001	NODAWAYCO	161.0	1	153	147.4	147.7	4.8%	S1399 to Humboldt	XS533160>533187>\$1
635034	CLRND 5	161.0	560001	NODAWAYCO	161.0	1	153	147.4	147.7	4.8%	S1399 to Humboldt	XS533366>533380>\$1
635034	CLRND 5	161.0	560001	NODAWAYCO	161.0	1	153	147.4	147.7	4.8%	S1399 to Humboldt	XS533234>533236>\$1
635034	CLRND 5	161.0	560001	NODAWAYCO	161.0	1	153	147.4	147.7	4.8%	S1399 to Humboldt	XS533045>533046>\$1

635034	CLRND 5	161.0	560001	NODAWAYCO	161.0	1	153	147.4	147.7	4.8%	S1399 to Humboldt	XS533166>533175>\$1
635034	CLRND 5	161.0	560001	NODAWAYCO	161.0	1	153	147.4	147.7	4.8%	S1399 to Humboldt	XS533261>533281>\$1
635034	CLRND 5	161.0	560001	NODAWAYCO	161.0	1	153	147.4	147.7	4.8%	S1399 to Humboldt	XS533364>533377>\$1
635034	CLRND 5	161.0	560001	NODAWAYCO	161.0	1	153	147.4	147.7	4.8%	S1399 to Humboldt	XS533269>533270>\$1
635034	CLRND 5	161.0	560001	NODAWAYCO	161.0	1	153	147.4	147.7	4.8%	S1399 to Humboldt	XS532982>532984>\$1
635034	CLRND 5	161.0	560001	NODAWAYCO	161.0	1	153	147.4	147.7	4.8%	S1399 to Humboldt	XS533008>533021>\$1
635034	CLRND 5	161.0	560001	NODAWAYCO	161.0	1	153	147.3	147.7	4.8%	S1399 to Humboldt	XS533151>533194>\$1
635034	CLRND 5	161.0	560001	NODAWAYCO	161.0	1	153	147.4	147.7	4.8%	S1399 to Humboldt	XS533244>533268>\$2
635034	CLRND 5	161.0	560001	NODAWAYCO	161.0	1	153	147.3	147.7	4.8%	S1399 to Humboldt	XS533039>533062>\$1
635034	CLRND 5	161.0	560001	NODAWAYCO	161.0	1	153	147.4	147.7	4.8%	S1399 to Humboldt	XS533328>533335>\$3
635034	CLRND 5	161.0	560001	NODAWAYCO	161.0	1	153	147.4	147.7	4.8%	S1399 to Humboldt	XS533375>533379>\$1
635034	CLRND 5	161.0	560001	NODAWAYCO	161.0	1	153	147.3	147.7	4.8%	S1399 to Humboldt	XS533062>533068>\$1
635034	CLRND 5	161.0	560001	NODAWAYCO	161.0	1	153	147.3	147.7	4.8%	S1399 to Humboldt	XS533002>533688>533089\$1
635034	CLRND 5	161.0	560001	NODAWAYCO	161.0	1	153	147.4	147.7	4.8%	S1399 to Humboldt	XS533180>533182>\$1
635034	CLRND 5	161.0	560001	NODAWAYCO	161.0	1	153	147.4	147.7	4.8%	S1399 to Humboldt	XS532981>532982>\$1
635034	CLRND 5	161.0	560001	NODAWAYCO	161.0	1	153	147.4	147.7	4.8%	S1399 to Humboldt	XS533049>533806>533108\$1
635034	CLRND 5	161.0	560001	NODAWAYCO	161.0	1	153	147.4	147.7	4.8%	S1399 to Humboldt	XS533182>533884>\$1
635034	CLRND 5	161.0	560001	NODAWAYCO	161.0	1	153	147.4	147.7	4.8%	S1399 to Humboldt	XS533321>533330>\$1
635034	CLRND 5	161.0	560001	NODAWAYCO	161.0	1	153	147.4	147.7	4.8%	S1399 to Humboldt	XS533374>533438>\$1
635034	CLRND 5	161.0	560001	NODAWAYCO	161.0	1	153	147.4	147.7	4.8%	S1399 to Humboldt	XS533380>533429>\$1
635034	CLRND 5	161.0	560001	NODAWAYCO	161.0	1	153	147.4	147.7	4.8%	S1399 to Humboldt	XS533250>533264>\$1
635034	CLRND 5	161.0	560001	NODAWAYCO	161.0	1	153	147.4	147.7	4.8%	S1399 to Humboldt	XS533375>533381>\$1
635034	CLRND 5	161.0	560001	NODAWAYCO	161.0	1	153	147.4	147.7	4.8%	S1399 to Humboldt	XS533326>533335>\$1
635034	CLRND 5	161.0	560001	NODAWAYCO	161.0	1	153	147.4	147.7	4.8%	S1399 to Humboldt	XS533182>533187>\$1
635034	CLRND 5	161.0	560001	NODAWAYCO	161.0	1	153	147.4	147.7	4.8%	S1399 to Humboldt	XS533211>533218>\$1
635034	CLRND 5	161.0	560001	NODAWAYCO	161.0	1	153	147.3	147.7	4.8%	S1399 to Humboldt	XS533039>533793>533105\$1
635034	CLRND 5	161.0	560001	NODAWAYCO	161.0	1	153	147.4	147.7	4.8%	S1399 to Humboldt	XS532981>533543>533080\$1

635034	CLRNDA 5	161.0	560001	NODAWAYCO	161.0	1	153	147.4	147.7	4.8%	S1399 to Humboldt	XS533028>533067>\$1
635034	CLRNDA 5	161.0	560001	NODAWAYCO	161.0	1	153	147.3	147.7	4.8%	S1399 to Humboldt	XS533182>533270>\$1
635034	CLRNDA 5	161.0	560001	NODAWAYCO	161.0	1	153	147.4	147.7	4.8%	S1399 to Humboldt	XS533378>533379>\$2
635034	CLRNDA 5	161.0	560001	NODAWAYCO	161.0	1	153	147.4	147.7	4.8%	S1399 to Humboldt	XS533328>533330>\$1
635034	CLRNDA 5	161.0	560001	NODAWAYCO	161.0	1	153	147.3	147.7	4.8%	S1399 to Humboldt	XS533151>533166>\$1
635034	CLRNDA 5	161.0	560001	NODAWAYCO	161.0	1	153	147.4	147.7	4.8%	S1399 to Humboldt	XS533245>533256>\$1
635034	CLRNDA 5	161.0	560001	NODAWAYCO	161.0	1	153	147.4	147.7	4.8%	S1399 to Humboldt	XS533180>533462>533448\$1
635034	CLRNDA 5	161.0	560001	NODAWAYCO	161.0	1	153	147.4	147.7	4.8%	S1399 to Humboldt	XS533328>533335>\$1
635034	CLRNDA 5	161.0	560001	NODAWAYCO	161.0	1	153	147.4	147.7	4.8%	S1399 to Humboldt	XS532981>533543>533081\$1
635034	CLRNDA 5	161.0	560001	NODAWAYCO	161.0	1	153	147.4	147.7	4.8%	S1399 to Humboldt	XS533180>533252>\$1
635034	CLRNDA 5	161.0	560001	NODAWAYCO	161.0	1	153	147.4	147.7	4.8%	S1399 to Humboldt	XS533245>533257>\$1
635034	CLRNDA 5	161.0	560001	NODAWAYCO	161.0	1	153	147.4	147.7	4.8%	S1399 to Humboldt	XS533375>533379>\$2
635034	CLRNDA 5	161.0	560001	NODAWAYCO	161.0	1	153	147.4	147.7	4.8%	S1399 to Humboldt	XS533039>533042>\$1
635034	CLRNDA 5	161.0	560001	NODAWAYCO	161.0	1	153	147.3	147.7	4.8%	S1399 to Humboldt	XS533372>533377>\$1
635034	CLRNDA 5	161.0	560001	NODAWAYCO	161.0	1	153	147.4	147.7	4.8%	S1399 to Humboldt	XS533244>533268>\$1
635034	CLRNDA 5	161.0	560001	NODAWAYCO	161.0	1	153	147.4	147.7	4.8%	S1399 to Humboldt	XS533185>533186>\$1
635034	CLRNDA 5	161.0	560001	NODAWAYCO	161.0	1	153	147.4	147.7	4.8%	S1399 to Humboldt	XS533248>533252>\$1
635034	CLRNDA 5	161.0	560001	NODAWAYCO	161.0	1	153	147.4	147.7	4.8%	S1399 to Humboldt	XS533066>533842>\$1
635034	CLRNDA 5	161.0	560001	NODAWAYCO	161.0	1	153	147.3	147.7	4.8%	S1399 to Humboldt	XS533179>533194>\$1
635034	CLRNDA 5	161.0	560001	NODAWAYCO	161.0	1	153	147.4	147.7	4.8%	S1399 to Humboldt	XS533049>533805>533109\$1
635034	CLRNDA 5	161.0	560001	NODAWAYCO	161.0	1	153	147.4	147.7	4.8%	S1399 to Humboldt	XS533038>533074>\$1
635034	CLRNDA 5	161.0	560001	NODAWAYCO	161.0	1	153	147.4	147.7	4.8%	S1399 to Humboldt	XS533411>533412>\$1
635034	CLRNDA 5	161.0	560001	NODAWAYCO	161.0	1	153	147.4	147.7	4.8%	S1399 to Humboldt	XS533244>533246>\$1
635034	CLRNDA 5	161.0	560001	NODAWAYCO	161.0	1	153	147.4	147.7	4.8%	S1399 to Humboldt	XS532984>533063>\$1
635034	CLRNDA 5	161.0	560001	NODAWAYCO	161.0	1	153	147.4	147.7	4.8%	S1399 to Humboldt	XS533039>533066>\$1
635034	CLRNDA 5	161.0	560001	NODAWAYCO	161.0	1	153	147.3	147.7	4.8%	S1399 to Humboldt	XS533253>533270>\$1
635034	CLRNDA 5	161.0	560001	NODAWAYCO	161.0	1	153	147.4	147.7	4.8%	S1399 to Humboldt	XS533372>533374>\$1

635034	CLRND 5	161.0	560001	NODAWAYCO	161.0	1	153	147.4	147.7	4.8%	S1399 to Humboldt	XS533064>533840>533112\$1
635034	CLRND 5	161.0	560001	NODAWAYCO	161.0	1	153	147.4	147.7	4.8%	S1399 to Humboldt	XS533179>533185>\$1
635034	CLRND 5	161.0	560001	NODAWAYCO	161.0	1	153	147.4	147.7	4.8%	S1399 to Humboldt	XS533003>533697>533090\$1
635034	CLRND 5	161.0	560001	NODAWAYCO	161.0	1	153	147.4	147.7	4.8%	S1399 to Humboldt	XS533250>533280>\$1
635034	CLRND 5	161.0	560001	NODAWAYCO	161.0	1	153	147.3	147.7	4.8%	S1399 to Humboldt	XS533005>533021>\$1
635034	CLRND 5	161.0	560001	NODAWAYCO	161.0	1	153	147.4	147.7	4.8%	S1399 to Humboldt	XS533003>533008>\$1
635034	CLRND 5	161.0	560001	NODAWAYCO	161.0	1	153	147.4	147.7	4.8%	S1399 to Humboldt	XS533329>533342>\$1
635034	CLRND 5	161.0	560001	NODAWAYCO	161.0	1	153	147.4	147.7	4.8%	S1399 to Humboldt	XS532984>532992>\$1
635034	CLRND 5	161.0	560001	NODAWAYCO	161.0	1	153	147.4	147.7	4.8%	S1399 to Humboldt	XS533244>533249>\$1
635034	CLRND 5	161.0	560001	NODAWAYCO	161.0	1	153	147.4	147.7	4.8%	S1399 to Humboldt	XS533153>533156>\$1
635034	CLRND 5	161.0	560001	NODAWAYCO	161.0	1	153	147.4	147.7	4.8%	S1399 to Humboldt	XS652504>652538>\$1
635034	CLRND 5	161.0	560001	NODAWAYCO	161.0	1	153	147.3	147.7	4.8%	S1399 to Humboldt	XS652508>652551>\$1
635034	CLRND 5	161.0	560001	NODAWAYCO	161.0	1	153	147.3	147.7	4.8%	S1399 to Humboldt	XS652482>652495>\$1
635034	CLRND 5	161.0	560001	NODAWAYCO	161.0	1	153	147.4	147.7	4.8%	S1399 to Humboldt	XS652565>652536>\$1
635034	CLRND 5	161.0	560001	NODAWAYCO	161.0	1	153	147.3	147.7	4.8%	S1399 to Humboldt	XS652534>652432>\$1
635034	CLRND 5	161.0	560001	NODAWAYCO	161.0	1	153	147.4	147.7	4.8%	S1399 to Humboldt	XS652530>652539>\$1
635034	CLRND 5	161.0	560001	NODAWAYCO	161.0	1	153	147.4	147.7	4.8%	S1399 to Humboldt	XS659154>659195>\$1
635034	CLRND 5	161.0	560001	NODAWAYCO	161.0	1	153	147.3	147.7	4.8%	S1399 to Humboldt	XS659154>659188>\$1
635034	CLRND 5	161.0	560001	NODAWAYCO	161.0	1	153	147.4	147.7	4.8%	S1399 to Humboldt	XS652511>652532>\$1
635034	CLRND 5	161.0	560001	NODAWAYCO	161.0	1	153	147.4	147.7	4.8%	S1399 to Humboldt	XS659192>659239>\$1
635034	CLRND 5	161.0	560001	NODAWAYCO	161.0	1	153	147.4	147.7	4.8%	S1399 to Humboldt	XS652518>659123>\$1
635034	CLRND 5	161.0	560001	NODAWAYCO	161.0	1	153	147.4	147.7	4.8%	S1399 to Humboldt	XS652551>603030>\$1
635034	CLRND 5	161.0	560001	NODAWAYCO	161.0	1	153	147.4	147.7	4.8%	S1399 to Humboldt	XS652512>660001>\$1
635034	CLRND 5	161.0	560001	NODAWAYCO	161.0	1	153	147.4	147.7	4.8%	S1399 to Humboldt	XS652609>660004>\$1
635034	CLRND 5	161.0	560001	NODAWAYCO	161.0	1	153	147.4	147.7	4.8%	S1399 to Humboldt	XS652466>652441>\$1
635034	CLRND 5	161.0	560001	NODAWAYCO	161.0	1	153	147.4	147.7	4.8%	S1399 to Humboldt	XS652551>620211>\$1
635034	CLRND 5	161.0	560001	NODAWAYCO	161.0	1	153	147.4	147.7	4.8%	S1399 to Humboldt	XS659185>659187>\$1

635034	CLRNDA 5	161.0	560001	NODAWAYCO	161.0	1	153	147.3	147.7	4.8%	S1399 to Humboldt	XS659130>659132>\$2
635034	CLRNDA 5	161.0	560001	NODAWAYCO	161.0	1	153	147.3	147.7	4.8%	S1399 to Humboldt	XS652519>652521>\$1
635034	CLRNDA 5	161.0	560001	NODAWAYCO	161.0	1	153	147.3	147.7	4.8%	S1399 to Humboldt	XS652521>652527>\$1
635034	CLRNDA 5	161.0	560001	NODAWAYCO	161.0	1	153	147.3	147.7	4.8%	S1399 to Humboldt	XS659192>659197>\$1
635034	CLRNDA 5	161.0	560001	NODAWAYCO	161.0	1	153	147.3	147.7	4.8%	S1399 to Humboldt	XS652509>652510>\$2
635034	CLRNDA 5	161.0	560001	NODAWAYCO	161.0	1	153	147.3	147.7	4.8%	S1399 to Humboldt	XS659133>659131>\$1
635034	CLRNDA 5	161.0	560001	NODAWAYCO	161.0	1	153	147.4	147.7	4.8%	S1399 to Humboldt	XS652522>652531>\$1
635034	CLRNDA 5	161.0	560001	NODAWAYCO	161.0	1	153	147.4	147.7	4.8%	S1399 to Humboldt	XS656087>656089>\$1
635034	CLRNDA 5	161.0	560001	NODAWAYCO	161.0	1	153	147.4	147.7	4.8%	S1399 to Humboldt	XS652565>652566>652310\$1
635034	CLRNDA 5	161.0	560001	NODAWAYCO	161.0	1	153	147.4	147.7	4.8%	S1399 to Humboldt	XS652572>659134>659137\$1
635034	CLRNDA 5	161.0	560001	NODAWAYCO	161.0	1	153	147.4	147.7	4.8%	S1399 to Humboldt	XS652530>652614>\$1
635034	CLRNDA 5	161.0	560001	NODAWAYCO	161.0	1	153	147.4	147.7	4.8%	S1399 to Humboldt	XS652512>652533>\$1
635034	CLRNDA 5	161.0	560001	NODAWAYCO	161.0	1	153	147.4	147.7	4.8%	S1399 to Humboldt	XS652502>652517>\$1
635034	CLRNDA 5	161.0	560001	NODAWAYCO	161.0	1	153	147.3	147.7	4.8%	S1399 to Humboldt	XS652509>652510>\$1
635034	CLRNDA 5	161.0	560001	NODAWAYCO	161.0	1	153	147.3	147.7	4.8%	S1399 to Humboldt	XS652522>652438>\$1
635034	CLRNDA 5	161.0	560001	NODAWAYCO	161.0	1	153	147.4	147.7	4.8%	S1399 to Humboldt	XS652505>652474>\$1
635034	CLRNDA 5	161.0	560001	NODAWAYCO	161.0	1	153	147.4	147.7	4.8%	S1399 to Humboldt	XS652506>652507>652273\$1
635034	CLRNDA 5	161.0	560001	NODAWAYCO	161.0	1	153	147.4	147.7	4.8%	S1399 to Humboldt	XS652523>602004>\$1
635034	CLRNDA 5	161.0	560001	NODAWAYCO	161.0	1	153	147.4	147.7	4.8%	S1399 to Humboldt	XS652501>652510>\$1
635034	CLRNDA 5	161.0	560001	NODAWAYCO	161.0	1	153	147.3	147.7	4.8%	S1399 to Humboldt	XS659130>659132>\$1
635034	CLRNDA 5	161.0	560001	NODAWAYCO	161.0	1	153	147.3	147.7	4.8%	S1399 to Humboldt	XS659130>659188>\$1
635034	CLRNDA 5	161.0	560001	NODAWAYCO	161.0	1	153	147.4	147.7	4.8%	S1399 to Humboldt	XS652505>652524>\$1
635034	CLRNDA 5	161.0	560001	NODAWAYCO	161.0	1	153	147.4	147.7	4.8%	S1399 to Humboldt	XS652522>652533>\$1
635034	CLRNDA 5	161.0	560001	NODAWAYCO	161.0	1	153	147.4	147.7	4.8%	S1399 to Humboldt	XS652532>659121>\$1
635034	CLRNDA 5	161.0	560001	NODAWAYCO	161.0	1	153	147.3	147.7	4.8%	S1399 to Humboldt	XS652508>658072>\$1
635034	CLRNDA 5	161.0	560001	NODAWAYCO	161.0	1	153	147.4	147.7	4.8%	S1399 to Humboldt	XS652502>652524>\$1
635034	CLRNDA 5	161.0	560001	NODAWAYCO	161.0	1	153	147.4	147.7	4.8%	S1399 to Humboldt	XS652506>652507>652274\$1

635034	CLRNDA 5 161.0	560001	NODAWAYCO 161.0	1	153	147.3	147.7	4.8%	S1399 to Humboldt	XS652512>659203>\$1
635034	CLRNDA 5 161.0	560001	NODAWAYCO 161.0	1	153	147.4	147.7	4.8%	S1399 to Humboldt	XS652626>660006>\$1
635034	CLRNDA 5 161.0	560001	NODAWAYCO 161.0	1	153	147.4	147.7	4.8%	S1399 to Humboldt	XS652572>659238>\$1
635034	CLRNDA 5 161.0	560001	NODAWAYCO 161.0	1	153	147.3	147.7	4.8%	S1399 to Humboldt	XS659133>659209>\$1
635034	CLRNDA 5 161.0	560001	NODAWAYCO 161.0	1	153	147.4	147.7	4.8%	S1399 to Humboldt	XS652626>660007>\$1
635034	CLRNDA 5 161.0	560001	NODAWAYCO 161.0	1	153	147.4	147.7	4.8%	S1399 to Humboldt	XS652500>652531>\$1
635034	CLRNDA 5 161.0	560001	NODAWAYCO 161.0	1	153	147.4	147.7	4.8%	S1399 to Humboldt	XS652565>652566>652308\$1
635034	CLRNDA 5 161.0	560001	NODAWAYCO 161.0	1	153	147.3	147.7	4.8%	S1399 to Humboldt	XS659134>659210>\$1
635034	CLRNDA 5 161.0	560001	NODAWAYCO 161.0	1	153	147.4	147.7	4.8%	S1399 to Humboldt	XS652526>652626>652627\$1
635034	CLRNDA 5 161.0	560001	NODAWAYCO 161.0	1	153	147.4	147.7	4.8%	S1399 to Humboldt	XS652507>652519>\$4
635034	CLRNDA 5 161.0	560001	NODAWAYCO 161.0	1	153	147.4	147.7	4.8%	S1399 to Humboldt	XS652517>659121>\$1
635034	CLRNDA 5 161.0	560001	NODAWAYCO 161.0	1	153	147.4	147.7	4.8%	S1399 to Humboldt	XS652463>652525>\$1
635034	CLRNDA 5 161.0	560001	NODAWAYCO 161.0	1	153	147.4	147.7	4.8%	S1399 to Humboldt	XS652464>652453>\$1
635034	CLRNDA 5 161.0	560001	NODAWAYCO 161.0	1	153	147.4	147.7	4.8%	S1399 to Humboldt	XS652537>652538>652293\$1
635034	CLRNDA 5 161.0	560001	NODAWAYCO 161.0	1	153	147.4	147.7	4.8%	S1399 to Humboldt	XS652607>662100>\$1
635034	CLRNDA 5 161.0	560001	NODAWAYCO 161.0	1	153	147.4	147.7	4.8%	S1399 to Humboldt	XS652463>652510>\$1
635034	CLRNDA 5 161.0	560001	NODAWAYCO 161.0	1	153	147.4	147.7	4.8%	S1399 to Humboldt	XS652606>652609>652608\$1
635034	CLRNDA 5 161.0	560001	NODAWAYCO 161.0	1	153	147.3	147.7	4.8%	S1399 to Humboldt	XS652527>661038>\$1
635034	CLRNDA 5 161.0	560001	NODAWAYCO 161.0	1	153	147.4	147.7	4.8%	S1399 to Humboldt	XS652507>652514>\$2
635034	CLRNDA 5 161.0	560001	NODAWAYCO 161.0	1	153	147.4	147.7	4.8%	S1399 to Humboldt	XS652464>659113>\$1
635034	CLRNDA 5 161.0	560001	NODAWAYCO 161.0	1	153	147.4	147.7	4.8%	S1399 to Humboldt	XS652514>652530>\$2
635034	CLRNDA 5 161.0	560001	NODAWAYCO 161.0	1	153	147.4	147.7	4.8%	S1399 to Humboldt	XS652526>652536>\$1
635034	CLRNDA 5 161.0	560001	NODAWAYCO 161.0	1	153	147.4	147.7	4.8%	S1399 to Humboldt	XS652507>652519>\$1
635034	CLRNDA 5 161.0	560001	NODAWAYCO 161.0	1	153	147.4	147.7	4.8%	S1399 to Humboldt	XS652550>652554>\$1
635034	CLRNDA 5 161.0	560001	NODAWAYCO 161.0	1	153	147.4	147.7	4.8%	S1399 to Humboldt	XS652507>652519>\$3
635034	CLRNDA 5 161.0	560001	NODAWAYCO 161.0	1	153	147.3	147.7	4.8%	S1399 to Humboldt	XS652398>652526>\$1
635034	CLRNDA 5 161.0	560001	NODAWAYCO 161.0	1	153	147.3	147.7	4.8%	S1399 to Humboldt	XS652465>652447>\$1

635034	CLRND 5	161.0	560001	NODAWAYCO	161.0	1	153	147.4	147.7	4.8%	S1399 to Humboldt	XS659195>659245>\$1
635034	CLRND 5	161.0	560001	NODAWAYCO	161.0	1	153	147.3	147.7	4.8%	S1399 to Humboldt	XS659247>659248>\$1
635034	CLRND 5	161.0	560001	NODAWAYCO	161.0	1	153	147.4	147.7	4.8%	S1399 to Humboldt	XS652514>652614>\$1
635034	CLRND 5	161.0	560001	NODAWAYCO	161.0	1	153	147.4	147.7	4.8%	S1399 to Humboldt	XS652507>652514>\$1
635034	CLRND 5	161.0	560001	NODAWAYCO	161.0	1	153	147.3	147.7	4.8%	S1399 to Humboldt	XS652465>652431>\$1
635034	CLRND 5	161.0	560001	NODAWAYCO	161.0	1	153	147.4	147.7	4.8%	S1399 to Humboldt	XS652507>652519>\$2
635034	CLRND 5	161.0	560001	NODAWAYCO	161.0	1	153	147.3	147.7	4.8%	S1399 to Humboldt	XS659210>659209>\$1
635034	CLRND 5	161.0	560001	NODAWAYCO	161.0	1	153	147.4	147.7	4.8%	S1399 to Humboldt	CB971-BUSNCU
635034	CLRND 5	161.0	560001	NODAWAYCO	161.0	1	153	147.4	147.7	4.8%	S1399 to Humboldt	CB1210-17&T7
635034	CLRND 5	161.0	560001	NODAWAYCO	161.0	1	153	147.3	147.7	4.8%	S1399 to Humboldt	CB909-BUS
635034	CLRND 5	161.0	560001	NODAWAYCO	161.0	1	153	147.4	147.7	4.8%	S1399 to Humboldt	CB1209-311T1
635034	CLRND 5	161.0	560001	NODAWAYCO	161.0	1	153	147.4	147.7	4.8%	S1399 to Humboldt	CB1209-312T1
635034	CLRND 5	161.0	560001	NODAWAYCO	161.0	1	153	147.3	147.7	4.8%	S1399 to Humboldt	CB910BUS1210
635034	CLRND 5	161.0	560001	NODAWAYCO	161.0	1	153	147.3	147.7	4.8%	S1399 to Humboldt	LES7101
635034	CLRND 5	161.0	560001	NODAWAYCO	161.0	1	153	147.3	147.7	4.8%	S1399 to Humboldt	LES7102
635034	CLRND 5	161.0	560001	NODAWAYCO	161.0	1	153	147.3	147.7	4.8%	S1399 to Humboldt	CB970-EN-NCU
635034	CLRND 5	161.0	560001	NODAWAYCO	161.0	1	153	147.3	147.7	4.8%	S1399 to Humboldt	LES7103
635034	CLRND 5	161.0	560001	NODAWAYCO	161.0	1	153	147.4	147.7	4.8%	S1399 to Humboldt	CB906S69BSC2
635034	CLRND 5	161.0	560001	NODAWAYCO	161.0	1	153	147.4	147.7	4.8%	S1399 to Humboldt	LES8501
635034	CLRND 5	161.0	560001	NODAWAYCO	161.0	1	153	147.4	147.7	4.8%	S1399 to Humboldt	LES8505
635034	CLRND 5	161.0	560001	NODAWAYCO	161.0	1	153	147.4	147.7	4.8%	S1399 to Humboldt	LES8503
635034	CLRND 5	161.0	560001	NODAWAYCO	161.0	1	153	147.4	147.7	4.8%	S1399 to Humboldt	LES8504
635034	CLRND 5	161.0	560001	NODAWAYCO	161.0	1	153	147.3	147.7	4.8%	S1399 to Humboldt	D-CIRCUIT #4
635034	CLRND 5	161.0	560001	NODAWAYCO	161.0	1	153	147.4	147.7	4.8%	S1399 to Humboldt	CB1237-BUS
635034	CLRND 5	161.0	560001	NODAWAYCO	161.0	1	153	147.4	147.7	4.8%	S1399 to Humboldt	LES6203
635034	CLRND 5	161.0	560001	NODAWAYCO	161.0	1	153	147.4	147.7	4.8%	S1399 to Humboldt	CB914A-88-T1
635034	CLRND 5	161.0	560001	NODAWAYCO	161.0	1	153	147.4	147.7	4.8%	S1399 to Humboldt	LES3802B

635034	CLRND 5	161.0	560001	NODAWAYCO	161.0	1	153	147.4	147.7	4.8%	S1399 to Humboldt	CB1253-35&37
635034	CLRND 5	161.0	560001	NODAWAYCO	161.0	1	153	147.3	147.7	4.8%	S1399 to Humboldt	CB917-BUS
635034	CLRND 5	161.0	560001	NODAWAYCO	161.0	1	153	147.4	147.7	4.8%	S1399 to Humboldt	CB916-06-40
635034	CLRND 5	161.0	560001	NODAWAYCO	161.0	1	153	147.4	147.7	4.8%	S1399 to Humboldt	CB930-18-39
635034	CLRND 5	161.0	560001	NODAWAYCO	161.0	1	153	147.3	147.7	4.8%	S1399 to Humboldt	LES7002
635034	CLRND 5	161.0	560001	NODAWAYCO	161.0	1	153	147.4	147.7	4.8%	S1399 to Humboldt	CB962-BUS&NH
635034	CLRND 5	161.0	560001	NODAWAYCO	161.0	1	153	147.4	147.7	4.8%	S1399 to Humboldt	LES0006
635034	CLRND 5	161.0	560001	NODAWAYCO	161.0	1	153	147.4	147.7	4.8%	S1399 to Humboldt	ELKCTY3_GEN
635034	CLRND 5	161.0	560001	NODAWAYCO	161.0	1	153	147.4	147.7	4.8%	S1399 to Humboldt	CB938-06N-95
635034	CLRND 5	161.0	560001	NODAWAYCO	161.0	1	153	147.4	147.7	4.8%	S1399 to Humboldt	CB939-09-MUD
635034	CLRND 5	161.0	560001	NODAWAYCO	161.0	1	153	147.4	147.7	4.8%	S1399 to Humboldt	CB914A-14-88
635034	CLRND 5	161.0	560001	NODAWAYCO	161.0	1	153	147.4	147.7	4.8%	S1399 to Humboldt	CB939-30-MUD
635034	CLRND 5	161.0	560001	NODAWAYCO	161.0	1	153	147.4	147.7	4.8%	S1399 to Humboldt	CB938-06S-95
635034	CLRND 5	161.0	560001	NODAWAYCO	161.0	1	153	147.4	147.7	4.8%	S1399 to Humboldt	901-JCT-910
635034	CLRND 5	161.0	560001	NODAWAYCO	161.0	1	153	147.4	147.7	4.8%	S1399 to Humboldt	CBFREM-G
635034	CLRND 5	161.0	560001	NODAWAYCO	161.0	1	153	147.3	147.7	4.8%	S1399 to Humboldt	CB906N69CBUS
635034	CLRND 5	161.0	560001	NODAWAYCO	161.0	1	153	147.4	147.7	4.8%	S1399 to Humboldt	LN-1175B
635034	CLRND 5	161.0	560001	NODAWAYCO	161.0	1	153	147.3	147.7	4.8%	S1399 to Humboldt	CBFREM-D-C-B
635034	CLRND 5	161.0	560001	NODAWAYCO	161.0	1	153	147.3	147.7	4.8%	S1399 to Humboldt	BKR-HLD-3001
635034	CLRND 5	161.0	560001	NODAWAYCO	161.0	1	153	147.3	147.7	4.8%	S1399 to Humboldt	CB901-JS&BUS
635034	CLRND 5	161.0	560001	NODAWAYCO	161.0	1	153	147.4	147.7	4.8%	S1399 to Humboldt	LES9006
635034	CLRND 5	161.0	560001	NODAWAYCO	161.0	1	153	147.4	147.7	4.8%	S1399 to Humboldt	LES9005B
635034	CLRND 5	161.0	560001	NODAWAYCO	161.0	1	153	147.4	147.7	4.8%	S1399 to Humboldt	XS533427>533428>\$1
635034	CLRND 5	161.0	560001	NODAWAYCO	161.0	1	153	147.4	147.7	4.8%	S1399 to Humboldt	XS542985>543018>\$1
635034	CLRND 5	161.0	560001	NODAWAYCO	161.0	1	153	147.3	147.7	4.8%	S1399 to Humboldt	XS533417>533427>\$1
635034	CLRND 5	161.0	560001	NODAWAYCO	161.0	1	153	147.3	147.7	4.8%	S1399 to Humboldt	XS541248>543095>\$1
635034	CLRND 5	161.0	560001	NODAWAYCO	161.0	1	153	147.4	147.7	4.8%	S1399 to Humboldt	XS542985>543011>\$1

635034	CLRNDA 5 161.0	560001	NODAWAYCO 161.0	1	153	147.4	147.7	4.8%	S1399 to Humboldt	XS541207>541239>\$1
635034	CLRNDA 5 161.0	560001	NODAWAYCO 161.0	1	153	147.4	147.7	4.8%	S1399 to Humboldt	XS533417>533426>\$1
635034	CLRNDA 5 161.0	560001	NODAWAYCO 161.0	1	153	147.4	147.7	4.8%	S1399 to Humboldt	XS533419>533513>533445\$1
635034	CLRNDA 5 161.0	560001	NODAWAYCO 161.0	1	153	147.3	147.7	4.8%	S1399 to Humboldt	XS541198>541342>541372\$1
635034	CLRNDA 5 161.0	560001	NODAWAYCO 161.0	1	153	147.4	147.7	4.8%	S1399 to Humboldt	XS542969>542995>\$1
635034	CLRNDA 5 161.0	560001	NODAWAYCO 161.0	1	153	147.4	147.7	4.8%	S1399 to Humboldt	XS541207>541341>\$1
635034	CLRNDA 5 161.0	560001	NODAWAYCO 161.0	1	153	147.3	147.7	4.8%	S1399 to Humboldt	XS543021>543025>\$1
635034	CLRNDA 5 161.0	560001	NODAWAYCO 161.0	1	153	147.4	147.7	4.8%	S1399 to Humboldt	XS543020>543023>\$1
635034	CLRNDA 5 161.0	560001	NODAWAYCO 161.0	1	153	147.4	147.7	4.8%	S1399 to Humboldt	XS542973>542976>\$1
635034	CLRNDA 5 161.0	560001	NODAWAYCO 161.0	1	153	147.4	147.7	4.8%	S1399 to Humboldt	XS543031>546742>\$1
635034	CLRNDA 5 161.0	560001	NODAWAYCO 161.0	1	153	147.3	147.7	4.8%	S1399 to Humboldt	XS541239>541295>\$1
635034	CLRNDA 5 161.0	560001	NODAWAYCO 161.0	1	153	147.3	147.7	4.8%	S1399 to Humboldt	XS543032>543040>\$1
635034	CLRNDA 5 161.0	560001	NODAWAYCO 161.0	1	153	147.4	147.7	4.8%	S1399 to Humboldt	XS541239>300709>\$1
635034	CLRNDA 5 161.0	560001	NODAWAYCO 161.0	1	153	147.4	147.7	4.8%	S1399 to Humboldt	XS543033>543047>\$1
635034	CLRNDA 5 161.0	560001	NODAWAYCO 161.0	1	153	147.4	147.7	4.8%	S1399 to Humboldt	XS533415>533416>\$1
635034	CLRNDA 5 161.0	560001	NODAWAYCO 161.0	1	153	147.4	147.7	4.8%	S1399 to Humboldt	XS543031>543032>\$1
635034	CLRNDA 5 161.0	560001	NODAWAYCO 161.0	1	153	147.4	147.7	4.8%	S1399 to Humboldt	XS541206>541246>\$1
635034	CLRNDA 5 161.0	560001	NODAWAYCO 161.0	1	153	147.4	147.7	4.8%	S1399 to Humboldt	XS541242>541303>\$2
635034	CLRNDA 5 161.0	560001	NODAWAYCO 161.0	1	153	147.3	147.7	4.8%	S1399 to Humboldt	XS542972>542973>543645\$22
635034	CLRNDA 5 161.0	560001	NODAWAYCO 161.0	1	153	147.4	147.7	4.8%	S1399 to Humboldt	XS541242>541303>\$1
635034	CLRNDA 5 161.0	560001	NODAWAYCO 161.0	1	153	147.3	147.7	4.8%	S1399 to Humboldt	XS533416>533429>\$1
635034	CLRNDA 5 161.0	560001	NODAWAYCO 161.0	1	153	147.4	147.7	4.8%	S1399 to Humboldt	XS542985>542990>\$1
635034	CLRNDA 5 161.0	560001	NODAWAYCO 161.0	1	153	147.3	147.7	4.8%	S1399 to Humboldt	XS541340>541290>\$1
635034	CLRNDA 5 161.0	560001	NODAWAYCO 161.0	1	153	147.3	147.7	4.8%	S1399 to Humboldt	XS541210>541382>\$1
635034	CLRNDA 5 161.0	560001	NODAWAYCO 161.0	1	153	147.3	147.7	4.8%	S1399 to Humboldt	XS541314>541315>\$1
635034	CLRNDA 5 161.0	560001	NODAWAYCO 161.0	1	153	147.4	147.7	4.8%	S1399 to Humboldt	XS542996>543638>\$1
635034	CLRNDA 5 161.0	560001	NODAWAYCO 161.0	1	153	147.4	147.7	4.8%	S1399 to Humboldt	XS542997>543639>\$1

635034	CLRNDA 5	161.0	560001	NODAWAYCO	161.0	1	153	147.4	147.7	4.8%	S1399 to Humboldt	XS543055>543066>\$1
635034	CLRNDA 5	161.0	560001	NODAWAYCO	161.0	1	153	147.4	147.7	4.8%	S1399 to Humboldt	XS542998>541220>\$1
635034	CLRNDA 5	161.0	560001	NODAWAYCO	161.0	1	153	147.4	147.7	4.8%	S1399 to Humboldt	XS542998>543009>\$1
635034	CLRNDA 5	161.0	560001	NODAWAYCO	161.0	1	153	147.4	147.7	4.8%	S1399 to Humboldt	XS533438>533439>\$1
635034	CLRNDA 5	161.0	560001	NODAWAYCO	161.0	1	153	147.3	147.7	4.8%	S1399 to Humboldt	XS542995>541207>\$1
635034	CLRNDA 5	161.0	560001	NODAWAYCO	161.0	1	153	147.4	147.7	4.8%	S1399 to Humboldt	XS541342>541344>\$1
635034	CLRNDA 5	161.0	560001	NODAWAYCO	161.0	1	153	147.4	147.7	4.8%	S1399 to Humboldt	XS533435>533441>\$1
635034	CLRNDA 5	161.0	560001	NODAWAYCO	161.0	1	153	147.3	147.7	4.8%	S1399 to Humboldt	XS541209>541271>\$1
635034	CLRNDA 5	161.0	560001	NODAWAYCO	161.0	1	153	147.3	147.7	4.8%	S1399 to Humboldt	XS542995>541245>\$1
635034	CLRNDA 5	161.0	560001	NODAWAYCO	161.0	1	153	147.4	147.7	4.8%	S1399 to Humboldt	XS541341>541344>\$1
635034	CLRNDA 5	161.0	560001	NODAWAYCO	161.0	1	153	147.4	147.7	4.8%	S1399 to Humboldt	XS541209>541234>\$1
635034	CLRNDA 5	161.0	560001	NODAWAYCO	161.0	1	153	147.4	147.7	4.8%	S1399 to Humboldt	XS542992>543035>\$1
635034	CLRNDA 5	161.0	560001	NODAWAYCO	161.0	1	153	147.4	147.7	4.8%	S1399 to Humboldt	XS541209>541272>\$1
635034	CLRNDA 5	161.0	560001	NODAWAYCO	161.0	1	153	147.4	147.7	4.8%	S1399 to Humboldt	XS542996>543001>\$1
635034	CLRNDA 5	161.0	560001	NODAWAYCO	161.0	1	153	147.4	147.7	4.8%	S1399 to Humboldt	XS541210>541223>\$1
635034	CLRNDA 5	161.0	560001	NODAWAYCO	161.0	1	153	147.4	147.7	4.8%	S1399 to Humboldt	XS542996>543040>\$1
635034	CLRNDA 5	161.0	560001	NODAWAYCO	161.0	1	153	147.4	147.7	4.8%	S1399 to Humboldt	XS542965>542968>\$1
635034	CLRNDA 5	161.0	560001	NODAWAYCO	161.0	1	153	147.4	147.7	4.8%	S1399 to Humboldt	XS533435>533441>\$2
635034	CLRNDA 5	161.0	560001	NODAWAYCO	161.0	1	153	147.3	147.7	4.8%	S1399 to Humboldt	XS541259>541382>\$1
635034	CLRNDA 5	161.0	560001	NODAWAYCO	161.0	1	153	147.4	147.7	4.8%	S1399 to Humboldt	XS541214>541161>\$1
635034	CLRNDA 5	161.0	560001	NODAWAYCO	161.0	1	153	147.4	147.7	4.8%	S1399 to Humboldt	XS541255>541169>\$1
635034	CLRNDA 5	161.0	560001	NODAWAYCO	161.0	1	153	147.4	147.7	4.8%	S1399 to Humboldt	XS541255>541169>\$2
635034	CLRNDA 5	161.0	560001	NODAWAYCO	161.0	1	153	147.4	147.7	4.8%	S1399 to Humboldt	XS533441>533455>\$2
635034	CLRNDA 5	161.0	560001	NODAWAYCO	161.0	1	153	147.4	147.7	4.8%	S1399 to Humboldt	XS533441>533455>\$1
635034	CLRNDA 5	161.0	560001	NODAWAYCO	161.0	1	153	147.4	147.7	4.8%	S1399 to Humboldt	XS543015>543018>\$1
635034	CLRNDA 5	161.0	560001	NODAWAYCO	161.0	1	153	147.4	147.7	4.8%	S1399 to Humboldt	XS541214>541230>\$1
635034	CLRNDA 5	161.0	560001	NODAWAYCO	161.0	1	153	147.4	147.7	4.8%	S1399 to Humboldt	XS541208>541308>\$2

635034	CLRNDA 5	161.0	560001	NODAWAYCO	161.0	1	153	147.3	147.7	4.8%	S1399 to Humboldt	XS542999>543008>\$1
635034	CLRNDA 5	161.0	560001	NODAWAYCO	161.0	1	153	147.3	147.7	4.8%	S1399 to Humboldt	XS543000>548820>\$1
635034	CLRNDA 5	161.0	560001	NODAWAYCO	161.0	1	153	147.4	147.7	4.8%	S1399 to Humboldt	XS542992>542993>\$1
635034	CLRNDA 5	161.0	560001	NODAWAYCO	161.0	1	153	147.4	147.7	4.8%	S1399 to Humboldt	XS541213>541214>\$1
635034	CLRNDA 5	161.0	560001	NODAWAYCO	161.0	1	153	147.3	147.7	4.8%	S1399 to Humboldt	XS541208>541308>\$1
635034	CLRNDA 5	161.0	560001	NODAWAYCO	161.0	1	153	147.4	147.7	4.8%	S1399 to Humboldt	XS541214>541160>\$1
635034	CLRNDA 5	161.0	560001	NODAWAYCO	161.0	1	153	147.4	147.7	4.8%	S1399 to Humboldt	XS543004>548807>\$1
635034	CLRNDA 5	161.0	560001	NODAWAYCO	161.0	1	153	147.4	147.7	4.8%	S1399 to Humboldt	XS543004>548808>\$1
635034	CLRNDA 5	161.0	560001	NODAWAYCO	161.0	1	153	147.4	147.7	4.8%	S1399 to Humboldt	XS533413>533416>\$1
635034	CLRNDA 5	161.0	560001	NODAWAYCO	161.0	1	153	147.3	147.7	4.8%	S1399 to Humboldt	XS543034>543052>\$1
635034	CLRNDA 5	161.0	560001	NODAWAYCO	161.0	1	153	147.3	147.7	4.8%	S1399 to Humboldt	XS542973>548814>\$1
635034	CLRNDA 5	161.0	560001	NODAWAYCO	161.0	1	153	147.4	147.7	4.8%	S1399 to Humboldt	XS542973>543000>\$1
635034	CLRNDA 5	161.0	560001	NODAWAYCO	161.0	1	153	147.4	147.7	4.8%	S1399 to Humboldt	XS541232>541264>\$1
635034	CLRNDA 5	161.0	560001	NODAWAYCO	161.0	1	153	147.3	147.7	4.8%	S1399 to Humboldt	XS543036>543043>\$1
635034	CLRNDA 5	161.0	560001	NODAWAYCO	161.0	1	153	147.4	147.7	4.8%	S1399 to Humboldt	XS542973>543000>\$2
635034	CLRNDA 5	161.0	560001	NODAWAYCO	161.0	1	153	147.4	147.7	4.8%	S1399 to Humboldt	XS542978>543049>\$1
635034	CLRNDA 5	161.0	560001	NODAWAYCO	161.0	1	153	147.4	147.7	4.8%	S1399 to Humboldt	XS542973>543080>\$12
635034	CLRNDA 5	161.0	560001	NODAWAYCO	161.0	1	153	147.4	147.7	4.8%	S1399 to Humboldt	XS542973>543080>\$11
635034	CLRNDA 5	161.0	560001	NODAWAYCO	161.0	1	153	147.4	147.7	4.8%	S1399 to Humboldt	XS543035>543076>\$1
635034	CLRNDA 5	161.0	560001	NODAWAYCO	161.0	1	153	147.4	147.7	4.8%	S1399 to Humboldt	XS543034>543076>\$1
635034	CLRNDA 5	161.0	560001	NODAWAYCO	161.0	1	153	147.4	147.7	4.8%	S1399 to Humboldt	XS541228>541269>\$1
635034	CLRNDA 5	161.0	560001	NODAWAYCO	161.0	1	153	147.4	147.7	4.8%	S1399 to Humboldt	XS533413>533416>\$2
635034	CLRNDA 5	161.0	560001	NODAWAYCO	161.0	1	153	147.4	147.7	4.8%	S1399 to Humboldt	XS541227>541229>\$1
635034	CLRNDA 5	161.0	560001	NODAWAYCO	161.0	1	153	147.4	147.7	4.8%	S1399 to Humboldt	XS541231>541350>\$1
635034	CLRNDA 5	161.0	560001	NODAWAYCO	161.0	1	153	147.3	147.7	4.8%	S1399 to Humboldt	XS543041>546651>\$1
635034	CLRNDA 5	161.0	560001	NODAWAYCO	161.0	1	153	147.4	147.7	4.8%	S1399 to Humboldt	XS541229>541267>\$1
635034	CLRNDA 5	161.0	560001	NODAWAYCO	161.0	1	153	147.3	147.7	4.8%	S1399 to Humboldt	XS541203>541247>\$1

635034	CLRND 5	161.0	560001	NODAWAYCO	161.0	1	153	147.4	147.7	4.8%	S1399 to Humboldt	XS541223>541224>\$1
635034	CLRND 5	161.0	560001	NODAWAYCO	161.0	1	153	147.3	147.7	4.8%	S1399 to Humboldt	XS542973>543020>\$1
635034	CLRND 5	161.0	560001	NODAWAYCO	161.0	1	153	147.4	147.7	4.8%	S1399 to Humboldt	XS542973>542997>\$2
635034	CLRND 5	161.0	560001	NODAWAYCO	161.0	1	153	147.3	147.7	4.8%	S1399 to Humboldt	XS541235>543091>\$1
635034	CLRND 5	161.0	560001	NODAWAYCO	161.0	1	153	147.4	147.7	4.8%	S1399 to Humboldt	XS542976>542985>\$1
635034	CLRND 5	161.0	560001	NODAWAYCO	161.0	1	153	147.4	147.7	4.8%	S1399 to Humboldt	XS533412>533413>\$1
635034	CLRND 5	161.0	560001	NODAWAYCO	161.0	1	153	147.4	147.7	4.8%	S1399 to Humboldt	XS533413>530623>\$1
635034	CLRND 5	161.0	560001	NODAWAYCO	161.0	1	153	147.4	147.7	4.8%	S1399 to Humboldt	XS543036>543048>\$1
635034	CLRND 5	161.0	560001	NODAWAYCO	161.0	1	153	147.4	147.7	4.8%	S1399 to Humboldt	XS542973>543011>\$1
635034	CLRND 5	161.0	560001	NODAWAYCO	161.0	1	153	147.4	147.7	4.8%	S1399 to Humboldt	XS541224>541245>\$1
635034	CLRND 5	161.0	560001	NODAWAYCO	161.0	1	153	147.4	147.7	4.8%	S1399 to Humboldt	XS533414>533435>\$1
635034	CLRND 5	161.0	560001	NODAWAYCO	161.0	1	153	147.4	147.7	4.8%	S1399 to Humboldt	XS543638>543639>\$1
635034	CLRND 5	161.0	560001	NODAWAYCO	161.0	1	153	147.3	147.7	4.8%	S1399 to Humboldt	XS631059>681520>\$1
635034	CLRND 5	161.0	560001	NODAWAYCO	161.0	1	153	147.4	147.7	4.8%	S1399 to Humboldt	XS631042>630002>\$1
635034	CLRND 5	161.0	560001	NODAWAYCO	161.0	1	153	147.3	147.7	4.8%	S1399 to Humboldt	XS631079>630007>\$1
635034	CLRND 5	161.0	560001	NODAWAYCO	161.0	1	153	147.3	147.7	4.8%	S1399 to Humboldt	XS631017>631020>\$1
635034	CLRND 5	161.0	560001	NODAWAYCO	161.0	1	153	147.4	147.7	4.8%	S1399 to Humboldt	XS631052>681528>\$1
635034	CLRND 5	161.0	560001	NODAWAYCO	161.0	1	153	147.4	147.7	4.8%	S1399 to Humboldt	XS631034>630340>\$1
635034	CLRND 5	161.0	560001	NODAWAYCO	161.0	1	153	147.4	147.7	4.8%	S1399 to Humboldt	XS631037>631114>\$1
635034	CLRND 5	161.0	560001	NODAWAYCO	161.0	1	153	147.4	147.7	4.8%	S1399 to Humboldt	XS631088>631094>\$1
635034	CLRND 5	161.0	560001	NODAWAYCO	161.0	1	153	147.4	147.7	4.8%	S1399 to Humboldt	XS631040>630066>\$2
635034	CLRND 5	161.0	560001	NODAWAYCO	161.0	1	153	147.3	147.7	4.8%	S1399 to Humboldt	XS631015>631016>\$1
635034	CLRND 5	161.0	560001	NODAWAYCO	161.0	1	153	147.4	147.7	4.8%	S1399 to Humboldt	XS631088>631142>\$1
635034	CLRND 5	161.0	560001	NODAWAYCO	161.0	1	153	147.4	147.7	4.8%	S1399 to Humboldt	XS631016>631080>\$1
635034	CLRND 5	161.0	560001	NODAWAYCO	161.0	1	153	147.3	147.7	4.8%	S1399 to Humboldt	XS631038>602039>\$1
635034	CLRND 5	161.0	560001	NODAWAYCO	161.0	1	153	147.3	147.7	4.8%	S1399 to Humboldt	XS631066>630177>\$1
635034	CLRND 5	161.0	560001	NODAWAYCO	161.0	1	153	147.4	147.7	4.8%	S1399 to Humboldt	XS631077>629112>\$1

635034	CLRNDA 5 161.0	560001	NODAWAYCO 161.0	1	153	147.4	147.7	4.8%	S1399 to Humboldt	XS631048>630213>\$1
635034	CLRNDA 5 161.0	560001	NODAWAYCO 161.0	1	153	147.4	147.7	4.8%	S1399 to Humboldt	XS631013>631017>\$1
635034	CLRNDA 5 161.0	560001	NODAWAYCO 161.0	1	153	147.4	147.7	4.8%	S1399 to Humboldt	XS631077>629112>\$2
635034	CLRNDA 5 161.0	560001	NODAWAYCO 161.0	1	153	147.4	147.7	4.8%	S1399 to Humboldt	XS613330>630189>\$1
635034	CLRNDA 5 161.0	560001	NODAWAYCO 161.0	1	153	147.4	147.7	4.8%	S1399 to Humboldt	XS631004>629105>\$2
635034	CLRNDA 5 161.0	560001	NODAWAYCO 161.0	1	153	147.3	147.7	4.8%	S1399 to Humboldt	XS631042>658066>\$2
635034	CLRNDA 5 161.0	560001	NODAWAYCO 161.0	1	153	147.4	147.7	4.8%	S1399 to Humboldt	XS631077>635607>\$1
635034	CLRNDA 5 161.0	560001	NODAWAYCO 161.0	1	153	147.4	147.7	4.8%	S1399 to Humboldt	XS631089>630017>\$1
635034	CLRNDA 5 161.0	560001	NODAWAYCO 161.0	1	153	147.4	147.7	4.8%	S1399 to Humboldt	XS631048>630214>\$1
635034	CLRNDA 5 161.0	560001	NODAWAYCO 161.0	1	153	147.4	147.7	4.8%	S1399 to Humboldt	XS631059>631125>\$1
635034	CLRNDA 5 161.0	560001	NODAWAYCO 161.0	1	153	147.3	147.7	4.8%	S1399 to Humboldt	XS543062>345221>\$1
635034	CLRNDA 5 161.0	560001	NODAWAYCO 161.0	1	153	147.4	147.7	4.8%	S1399 to Humboldt	XS631053>630003>\$1
635034	CLRNDA 5 161.0	560001	NODAWAYCO 161.0	1	153	147.4	147.7	4.8%	S1399 to Humboldt	XS631003>631010>\$1
635034	CLRNDA 5 161.0	560001	NODAWAYCO 161.0	1	153	147.4	147.7	4.8%	S1399 to Humboldt	XS631037>631108>\$1
635034	CLRNDA 5 161.0	560001	NODAWAYCO 161.0	1	153	147.4	147.7	4.8%	S1399 to Humboldt	XS631004>631008>\$1
635034	CLRNDA 5 161.0	560001	NODAWAYCO 161.0	1	153	147.3	147.7	4.8%	S1399 to Humboldt	XS631064>631065>\$1
635034	CLRNDA 5 161.0	560001	NODAWAYCO 161.0	1	153	147.3	147.7	4.8%	S1399 to Humboldt	XS631041>658066>\$2
635034	CLRNDA 5 161.0	560001	NODAWAYCO 161.0	1	153	147.4	147.7	4.8%	S1399 to Humboldt	XS631017>631032>\$1
635034	CLRNDA 5 161.0	560001	NODAWAYCO 161.0	1	153	147.3	147.7	4.8%	S1399 to Humboldt	XS631017>631022>\$1
635034	CLRNDA 5 161.0	560001	NODAWAYCO 161.0	1	153	147.3	147.7	4.8%	S1399 to Humboldt	XS631086>636210>\$1
635034	CLRNDA 5 161.0	560001	NODAWAYCO 161.0	1	153	147.4	147.7	4.8%	S1399 to Humboldt	XS631079>636020>\$1
635034	CLRNDA 5 161.0	560001	NODAWAYCO 161.0	1	153	147.4	147.7	4.8%	S1399 to Humboldt	XS631050>631051>\$1
635034	CLRNDA 5 161.0	560001	NODAWAYCO 161.0	1	153	147.4	147.7	4.8%	S1399 to Humboldt	XS631088>631089>\$1
635034	CLRNDA 5 161.0	560001	NODAWAYCO 161.0	1	153	147.4	147.7	4.8%	S1399 to Humboldt	XS631015>631032>\$1
635034	CLRNDA 5 161.0	560001	NODAWAYCO 161.0	1	153	147.4	147.7	4.8%	S1399 to Humboldt	XS631079>631121>\$1
635034	CLRNDA 5 161.0	560001	NODAWAYCO 161.0	1	153	147.4	147.7	4.8%	S1399 to Humboldt	XS631004>631081>\$1
635034	CLRNDA 5 161.0	560001	NODAWAYCO 161.0	1	153	147.4	147.7	4.8%	S1399 to Humboldt	XS631003>629109>\$1

635034	CLRND 5	161.0	560001	NODAWAYCO	161.0	1	153	147.4	147.7	4.8%	S1399 to Humboldt	XS631040>631041>\$1
635034	CLRND 5	161.0	560001	NODAWAYCO	161.0	1	153	147.4	147.7	4.8%	S1399 to Humboldt	XS631016>631168>\$1
635034	CLRND 5	161.0	560001	NODAWAYCO	161.0	1	153	147.4	147.7	4.8%	S1399 to Humboldt	XS631049>629083>\$1
635034	CLRND 5	161.0	560001	NODAWAYCO	161.0	1	153	147.4	147.7	4.8%	S1399 to Humboldt	XS631052>631053>\$1
635034	CLRND 5	161.0	560001	NODAWAYCO	161.0	1	153	147.4	147.7	4.8%	S1399 to Humboldt	XS631061>631098>\$1
635034	CLRND 5	161.0	560001	NODAWAYCO	161.0	1	153	147.4	147.7	4.8%	S1399 to Humboldt	XS631079>638010>\$1
635034	CLRND 5	161.0	560001	NODAWAYCO	161.0	1	153	147.4	147.7	4.8%	S1399 to Humboldt	XS631030>629109>\$2
635034	CLRND 5	161.0	560001	NODAWAYCO	161.0	1	153	147.4	147.7	4.8%	S1399 to Humboldt	XS631042>630002>\$2
635034	CLRND 5	161.0	560001	NODAWAYCO	161.0	1	153	147.4	147.7	4.8%	S1399 to Humboldt	XS631083>630027>\$1
635034	CLRND 5	161.0	560001	NODAWAYCO	161.0	1	153	147.4	147.7	4.8%	S1399 to Humboldt	XS631056>631100>\$1
635034	CLRND 5	161.0	560001	NODAWAYCO	161.0	1	153	147.4	147.7	4.8%	S1399 to Humboldt	XS631091>631182>\$1
635034	CLRND 5	161.0	560001	NODAWAYCO	161.0	1	153	147.4	147.7	4.8%	S1399 to Humboldt	XS631025>631026>\$1
635034	CLRND 5	161.0	560001	NODAWAYCO	161.0	1	153	147.4	147.7	4.8%	S1399 to Humboldt	XS631045>631163>\$1
635034	CLRND 5	161.0	560001	NODAWAYCO	161.0	1	153	147.3	147.7	4.8%	S1399 to Humboldt	XS560332>640076>\$1
635034	CLRND 5	161.0	560001	NODAWAYCO	161.0	1	153	147.4	147.7	4.8%	S1399 to Humboldt	XS631091>631094>\$1
635034	CLRND 5	161.0	560001	NODAWAYCO	161.0	1	153	147.4	147.7	4.8%	S1399 to Humboldt	XS631062>631097>\$1
635034	CLRND 5	161.0	560001	NODAWAYCO	161.0	1	153	147.4	147.7	4.8%	S1399 to Humboldt	XS631056>631125>\$1
635034	CLRND 5	161.0	560001	NODAWAYCO	161.0	1	153	147.4	147.7	4.8%	S1399 to Humboldt	XS631025>631146>\$1
635034	CLRND 5	161.0	560001	NODAWAYCO	161.0	1	153	147.4	147.7	4.8%	S1399 to Humboldt	XS631040>630066>\$1
635034	CLRND 5	161.0	560001	NODAWAYCO	161.0	1	153	147.4	147.7	4.8%	S1399 to Humboldt	XS631054>631056>\$1
635034	CLRND 5	161.0	560001	NODAWAYCO	161.0	1	153	147.4	147.7	4.8%	S1399 to Humboldt	XS631004>629105>\$1
635034	CLRND 5	161.0	560001	NODAWAYCO	161.0	1	153	147.4	147.7	4.8%	S1399 to Humboldt	XS631024>631095>\$1
635034	CLRND 5	161.0	560001	NODAWAYCO	161.0	1	153	147.4	147.7	4.8%	S1399 to Humboldt	XS631023>631024>\$1
635034	CLRND 5	161.0	560001	NODAWAYCO	161.0	1	153	147.3	147.7	4.8%	S1399 to Humboldt	XS631038>631039>\$1
635034	CLRND 5	161.0	560001	NODAWAYCO	161.0	1	153	147.4	147.7	4.8%	S1399 to Humboldt	XS631094>630025>\$1
635034	CLRND 5	161.0	560001	NODAWAYCO	161.0	1	153	147.4	147.7	4.8%	S1399 to Humboldt	XS631046>601002>605739\$9
635034	CLRND 5	161.0	560001	NODAWAYCO	161.0	1	153	147.3	147.7	4.8%	S1399 to Humboldt	XS631063>631065>\$1

635034	CLRND 5	161.0	560001	NODAWAYCO	161.0	1	153	147.4	147.7	4.8%	S1399 to Humboldt	XS631009>629104>\$1
635034	CLRND 5	161.0	560001	NODAWAYCO	161.0	1	153	147.4	147.7	4.8%	S1399 to Humboldt	XS631001>629101>\$2
635034	CLRND 5	161.0	560001	NODAWAYCO	161.0	1	153	147.4	147.7	4.8%	S1399 to Humboldt	XS543070>543071>\$1
635034	CLRND 5	161.0	560001	NODAWAYCO	161.0	1	153	147.4	147.7	4.8%	S1399 to Humboldt	XS631055>631120>\$1
635034	CLRND 5	161.0	560001	NODAWAYCO	161.0	1	153	147.4	147.7	4.8%	S1399 to Humboldt	XS631084>630013>\$1
635034	CLRND 5	161.0	560001	NODAWAYCO	161.0	1	153	147.4	147.7	4.8%	S1399 to Humboldt	XS631090>631181>\$1
635034	CLRND 5	161.0	560001	NODAWAYCO	161.0	1	153	147.4	147.7	4.8%	S1399 to Humboldt	XS631001>629101>\$1
635034	CLRND 5	161.0	560001	NODAWAYCO	161.0	1	153	147.4	147.7	4.8%	S1399 to Humboldt	XS631058>631059>\$1
635034	CLRND 5	161.0	560001	NODAWAYCO	161.0	1	153	147.4	147.7	4.8%	S1399 to Humboldt	XS631075>630006>\$1
635034	CLRND 5	161.0	560001	NODAWAYCO	161.0	1	153	147.4	147.7	4.8%	S1399 to Humboldt	XS631082>631128>\$1
635034	CLRND 5	161.0	560001	NODAWAYCO	161.0	1	153	147.4	147.7	4.8%	S1399 to Humboldt	XS631090>631092>\$1
635034	CLRND 5	161.0	560001	NODAWAYCO	161.0	1	153	147.4	147.7	4.8%	S1399 to Humboldt	XS613420>631050>\$1
635034	CLRND 5	161.0	560001	NODAWAYCO	161.0	1	153	147.4	147.7	4.8%	S1399 to Humboldt	XS631029>630341>\$1
635034	CLRND 5	161.0	560001	NODAWAYCO	161.0	1	153	147.4	147.7	4.8%	S1399 to Humboldt	XS631012>631015>\$1
635034	CLRND 5	161.0	560001	NODAWAYCO	161.0	1	153	147.4	147.7	4.8%	S1399 to Humboldt	XS631090>631091>\$1
635034	CLRND 5	161.0	560001	NODAWAYCO	161.0	1	153	147.4	147.7	4.8%	S1399 to Humboldt	XS631058>631061>\$1
635034	CLRND 5	161.0	560001	NODAWAYCO	161.0	1	153	147.4	147.7	4.8%	S1399 to Humboldt	XS631053>681530>\$1
635034	CLRND 5	161.0	560001	NODAWAYCO	161.0	1	153	147.4	147.7	4.8%	S1399 to Humboldt	XS631044>613040>\$1
635034	CLRND 5	161.0	560001	NODAWAYCO	161.0	1	153	147.4	147.7	4.8%	S1399 to Humboldt	XS631045>630097>\$1
635034	CLRND 5	161.0	560001	NODAWAYCO	161.0	1	153	147.4	147.7	4.8%	S1399 to Humboldt	XS631054>631055>\$1
635034	CLRND 5	161.0	560001	NODAWAYCO	161.0	1	153	147.4	147.7	4.8%	S1399 to Humboldt	XS631011>631028>\$1
635034	CLRND 5	161.0	560001	NODAWAYCO	161.0	1	153	147.4	147.7	4.8%	S1399 to Humboldt	XS631026>631101>\$1
635034	CLRND 5	161.0	560001	NODAWAYCO	161.0	1	153	147.4	147.7	4.8%	S1399 to Humboldt	XS631057>631061>\$1
635034	CLRND 5	161.0	560001	NODAWAYCO	161.0	1	153	147.4	147.7	4.8%	S1399 to Humboldt	XS631047>631155>\$1
635034	CLRND 5	161.0	560001	NODAWAYCO	161.0	1	153	147.3	147.7	4.8%	S1399 to Humboldt	XS631044>631174>\$1
635034	CLRND 5	161.0	560001	NODAWAYCO	161.0	1	153	147.4	147.7	4.8%	S1399 to Humboldt	XS631017>631019>\$1
635034	CLRND 5	161.0	560001	NODAWAYCO	161.0	1	153	147.4	147.7	4.8%	S1399 to Humboldt	XS631091>630681>\$1

635034	CLRND 5	161.0	560001	NODAWAYCO	161.0	1	153	147.4	147.7	4.8%	S1399 to Humboldt	XS631011>631170>\$1
635034	CLRND 5	161.0	560001	NODAWAYCO	161.0	1	153	147.4	147.7	4.8%	S1399 to Humboldt	XS631057>631120>\$1
635034	CLRND 5	161.0	560001	NODAWAYCO	161.0	1	153	147.3	147.7	4.8%	S1399 to Humboldt	XS631020>631092>\$1
635034	CLRND 5	161.0	560001	NODAWAYCO	161.0	1	153	147.4	147.7	3.8%	S1280 to Humboldt	XS640234>646399>\$1
635034	CLRND 5	161.0	560001	NODAWAYCO	161.0	1	153	147.4	147.7	3.8%	S1280 to Humboldt	XS532768>532796>\$1
635034	CLRND 5	161.0	560001	NODAWAYCO	161.0	1	153	147.4	147.7	3.8%	S1280 to Humboldt	XS652512>659275>\$1
635034	CLRND 5	161.0	560001	NODAWAYCO	161.0	1	153	147.4	147.7	3.8%	S1280 to Humboldt	XS541253>541257>\$1
635034	CLRND 5	161.0	560001	NODAWAYCO	161.0	1	153	147.4	147.7	3.8%	S1399 to Humboldt	XS631164>629984>\$1
635034	CLRND 5	161.0	560001	NODAWAYCO	161.0	1	153	147.4	147.7	3.8%	S1399 to Humboldt	XS631146>631147>\$1
635034	CLRND 5	161.0	560001	NODAWAYCO	161.0	1	153	147.4	147.7	3.8%	S1399 to Humboldt	XS631155>631152>\$1
635034	CLRND 5	161.0	560001	NODAWAYCO	161.0	1	153	147.4	147.7	3.8%	S1399 to Humboldt	XS635100>635101>\$2
635034	CLRND 5	161.0	560001	NODAWAYCO	161.0	1	153	147.4	147.7	3.8%	S1399 to Humboldt	XS635610>635611>\$1
635034	CLRND 5	161.0	560001	NODAWAYCO	161.0	1	153	147.4	147.7	3.8%	S1399 to Humboldt	XS636200>636205>\$1
635034	CLRND 5	161.0	560001	NODAWAYCO	161.0	1	153	147.4	147.7	3.8%	S1399 to Humboldt	XS631163>629983>\$1
635034	CLRND 5	161.0	560001	NODAWAYCO	161.0	1	153	147.4	147.7	3.8%	S1399 to Humboldt	XS636029>636030>\$1
635034	CLRND 5	161.0	560001	NODAWAYCO	161.0	1	153	147.4	147.7	3.8%	S1399 to Humboldt	XS631103>630821>\$1
635034	CLRND 5	161.0	560001	NODAWAYCO	161.0	1	153	147.4	147.7	3.8%	S1399 to Humboldt	XS631144>631157>\$1
635034	CLRND 5	161.0	560001	NODAWAYCO	161.0	1	153	147.4	147.7	3.8%	S1399 to Humboldt	XS631164>631183>\$1
635034	CLRND 5	161.0	560001	NODAWAYCO	161.0	1	153	147.4	147.7	3.8%	S1399 to Humboldt	XS635631>635641>\$1
635034	CLRND 5	161.0	560001	NODAWAYCO	161.0	1	153	147.4	147.7	3.8%	S1399 to Humboldt	XS631155>631169>\$1
635034	CLRND 5	161.0	560001	NODAWAYCO	161.0	1	153	147.4	147.7	3.8%	S1399 to Humboldt	XS631122>613040>\$1
635034	CLRND 5	161.0	560001	NODAWAYCO	161.0	1	153	147.4	147.7	3.8%	S1399 to Humboldt	XS631098>629091>\$2
635034	CLRND 5	161.0	560001	NODAWAYCO	161.0	1	153	147.4	147.7	3.8%	S1399 to Humboldt	XS631144>631158>\$1
635034	CLRND 5	161.0	560001	NODAWAYCO	161.0	1	153	147.4	147.7	3.8%	S1399 to Humboldt	XS635701>635702>\$1
635034	CLRND 5	161.0	560001	NODAWAYCO	161.0	1	153	147.4	147.7	3.8%	S1399 to Humboldt	XS635701>635702>\$2
635034	CLRND 5	161.0	560001	NODAWAYCO	161.0	1	153	147.4	147.7	3.8%	S1399 to Humboldt	XS631103>630821>\$2
635034	CLRND 5	161.0	560001	NODAWAYCO	161.0	1	153	147.4	147.7	3.8%	S1399 to Humboldt	XS635604>635610>\$1

635034	CLRND 5	161.0	560001	NODAWAYCO	161.0	1	153	147.4	147.7	3.8%	S1399 to Humboldt	XS635260>635360>\$1
635034	CLRND 5	161.0	560001	NODAWAYCO	161.0	1	153	147.4	147.7	3.8%	S1399 to Humboldt	XS631098>629091>\$1
635034	CLRND 5	161.0	560001	NODAWAYCO	161.0	1	153	147.4	147.7	3.8%	S1399 to Humboldt	XS635710>638000>\$1
635034	CLRND 5	161.0	560001	NODAWAYCO	161.0	1	153	147.4	147.7	3.8%	S1399 to Humboldt	XS631119>630053>\$1
635034	CLRND 5	161.0	560001	NODAWAYCO	161.0	1	153	147.4	147.7	3.8%	S1399 to Humboldt	XS636200>636202>\$1
635034	CLRND 5	161.0	560001	NODAWAYCO	161.0	1	153	147.4	147.7	3.8%	S1399 to Humboldt	XS631122>630139>\$1
635034	CLRND 5	161.0	560001	NODAWAYCO	161.0	1	153	147.4	147.7	3.8%	S1399 to Humboldt	XS631122>631123>\$1
635034	CLRND 5	161.0	560001	NODAWAYCO	161.0	1	153	147.4	147.7	3.8%	S1399 to Humboldt	XS631127>630128>\$1
635034	CLRND 5	161.0	560001	NODAWAYCO	161.0	1	153	147.4	147.7	3.8%	S1399 to Humboldt	XS631117>631119>\$1
635034	CLRND 5	161.0	560001	NODAWAYCO	161.0	1	153	147.4	147.7	3.8%	S1399 to Humboldt	XS635100>635101>\$1
635034	CLRND 5	161.0	560001	NODAWAYCO	161.0	1	153	147.4	147.7	3.8%	S1399 to Humboldt	XS635665>635666>\$1
635034	CLRND 5	161.0	560001	NODAWAYCO	161.0	1	153	147.4	147.7	3.8%	S1399 to Humboldt	XS631156>631153>\$1
635034	CLRND 5	161.0	560001	NODAWAYCO	161.0	1	153	147.4	147.7	3.8%	S1399 to Humboldt	XS635615>635616>\$1
635034	CLRND 5	161.0	560001	NODAWAYCO	161.0	1	153	147.4	147.7	3.8%	S1399 to Humboldt	XS636203>636204>\$1
635034	CLRND 5	161.0	560001	NODAWAYCO	161.0	1	153	147.4	147.7	3.8%	S1399 to Humboldt	XS631169>629987>\$1
635034	CLRND 5	161.0	560001	NODAWAYCO	161.0	1	153	147.4	147.7	3.8%	S1399 to Humboldt	XS636202>636203>\$1
635034	CLRND 5	161.0	560001	NODAWAYCO	161.0	1	153	147.4	147.7	3.8%	S1399 to Humboldt	XS635201>635203>\$1
635034	CLRND 5	161.0	560001	NODAWAYCO	161.0	1	153	147.4	147.7	3.8%	S1399 to Humboldt	XS631134>629985>\$1
635034	CLRND 5	161.0	560001	NODAWAYCO	161.0	1	153	147.4	147.7	3.8%	S1399 to Humboldt	XS635235>635236>\$1
635034	CLRND 5	161.0	560001	NODAWAYCO	161.0	1	153	147.4	147.7	3.8%	S1399 to Humboldt	XS635340>636029>\$1
635034	CLRND 5	161.0	560001	NODAWAYCO	161.0	1	153	147.4	147.7	3.8%	S1399 to Humboldt	XS635203>635204>\$1
635034	CLRND 5	161.0	560001	NODAWAYCO	161.0	1	153	147.4	147.7	3.8%	S1399 to Humboldt	XS636023>636025>\$1
635034	CLRND 5	161.0	560001	NODAWAYCO	161.0	1	153	147.4	147.7	3.8%	S1399 to Humboldt	XS636203>636206>\$1
635034	CLRND 5	161.0	560001	NODAWAYCO	161.0	1	153	147.4	147.7	3.8%	S1399 to Humboldt	XS631108>631109>\$2
635034	CLRND 5	161.0	560001	NODAWAYCO	161.0	1	153	147.4	147.7	3.8%	S1399 to Humboldt	XS636020>636021>\$3
635034	CLRND 5	161.0	560001	NODAWAYCO	161.0	1	153	147.4	147.7	3.8%	S1399 to Humboldt	XS631108>631109>\$1
635034	CLRND 5	161.0	560001	NODAWAYCO	161.0	1	153	147.4	147.7	3.8%	S1399 to Humboldt	XS631134>629985>\$2

635034	CLRNDA 5	161.0	560001	NODAWAYCO	161.0	1	153	147.4	147.7	3.8%	S1399 to Humboldt	XS635201>635220>\$1
635034	CLRNDA 5	161.0	560001	NODAWAYCO	161.0	1	153	147.4	147.7	3.8%	S1399 to Humboldt	XS635280>656570>\$1
635034	CLRNDA 5	161.0	560001	NODAWAYCO	161.0	1	153	147.4	147.7	3.8%	S1399 to Humboldt	XS631099>630022>\$1
635034	CLRNDA 5	161.0	560001	NODAWAYCO	161.0	1	153	147.4	147.7	3.8%	S1399 to Humboldt	XS636020>636021>\$1
635034	CLRNDA 5	161.0	560001	NODAWAYCO	161.0	1	153	147.4	147.7	3.8%	S1399 to Humboldt	XS636020>636021>\$2
635034	CLRNDA 5	161.0	560001	NODAWAYCO	161.0	1	153	147.4	147.7	3.8%	S1399 to Humboldt	XS635201>635203>\$2
635034	CLRNDA 5	161.0	560001	NODAWAYCO	161.0	1	153	147.4	147.7	3.8%	S1399 to Humboldt	XS635360>635361>\$1
635034	CLRNDA 5	161.0	560001	NODAWAYCO	161.0	1	153	147.4	147.7	3.8%	S1399 to Humboldt	XS635665>635666>\$2
635034	CLRNDA 5	161.0	560001	NODAWAYCO	161.0	1	153	147.4	147.7	3.8%	S1399 to Humboldt	XS636020>636023>\$1
635034	CLRNDA 5	161.0	560001	NODAWAYCO	161.0	1	153	147.4	147.7	3.8%	S1399 to Humboldt	XS631138>629992>\$1
635034	CLRNDA 5	161.0	560001	NODAWAYCO	161.0	1	153	147.4	147.7	3.8%	S1399 to Humboldt	XS635203>635235>\$1
635034	CLRNDA 5	161.0	560001	NODAWAYCO	161.0	1	153	147.4	147.7	3.8%	S1399 to Humboldt	XS635610>635611>\$2
635034	CLRNDA 5	161.0	560001	NODAWAYCO	161.0	1	153	147.4	147.7	3.8%	S1399 to Humboldt	XS636405>636410>\$1
635034	CLRNDA 5	161.0	560001	NODAWAYCO	161.0	1	153	147.4	147.7	3.8%	S1399 to Humboldt	XS636636>636670>\$2
635034	CLRNDA 5	161.0	560001	NODAWAYCO	161.0	1	153	147.4	147.7	3.8%	S1399 to Humboldt	XS640078>640357>\$1
635034	CLRNDA 5	161.0	560001	NODAWAYCO	161.0	1	153	147.4	147.7	3.8%	S1399 to Humboldt	XS636404>636405>\$1
635034	CLRNDA 5	161.0	560001	NODAWAYCO	161.0	1	153	147.4	147.7	3.8%	S1399 to Humboldt	XS636670>636671>\$2
635034	CLRNDA 5	161.0	560001	NODAWAYCO	161.0	1	153	147.4	147.7	3.8%	S1399 to Humboldt	XS640082>640083>\$2
635034	CLRNDA 5	161.0	560001	NODAWAYCO	161.0	1	153	147.4	147.7	3.8%	S1399 to Humboldt	XS636415>636425>\$1
635034	CLRNDA 5	161.0	560001	NODAWAYCO	161.0	1	153	147.4	147.7	3.8%	S1399 to Humboldt	XS640144>640196>\$1
635034	CLRNDA 5	161.0	560001	NODAWAYCO	161.0	1	153	147.4	147.7	3.8%	S1399 to Humboldt	XS640136>640137>\$2
635034	CLRNDA 5	161.0	560001	NODAWAYCO	161.0	1	153	147.4	147.7	3.8%	S1399 to Humboldt	XS640119>640127>\$1
635034	CLRNDA 5	161.0	560001	NODAWAYCO	161.0	1	153	147.4	147.7	3.8%	S1399 to Humboldt	XS640127>640157>\$1
635034	CLRNDA 5	161.0	560001	NODAWAYCO	161.0	1	153	147.4	147.7	3.8%	S1399 to Humboldt	XS640082>640083>\$1
635034	CLRNDA 5	161.0	560001	NODAWAYCO	161.0	1	153	147.4	147.7	3.8%	S1399 to Humboldt	XS640124>640136>\$1
635034	CLRNDA 5	161.0	560001	NODAWAYCO	161.0	1	153	147.4	147.7	3.8%	S1399 to Humboldt	XS640080>640228>\$1
635034	CLRNDA 5	161.0	560001	NODAWAYCO	161.0	1	153	147.4	147.7	3.8%	S1399 to Humboldt	XS636670>636671>\$1

635034	CLRND 5	161.0	560001	NODAWAYCO	161.0	1	153	147.4	147.7	3.8%	S1399 to Humboldt	XS640086>659193>\$1
635034	CLRND 5	161.0	560001	NODAWAYCO	161.0	1	153	147.4	147.7	3.8%	S1399 to Humboldt	XS636403>636404>\$1
635034	CLRND 5	161.0	560001	NODAWAYCO	161.0	1	153	147.4	147.7	3.8%	S1399 to Humboldt	XS640136>640137>\$1
635034	CLRND 5	161.0	560001	NODAWAYCO	161.0	1	153	147.4	147.7	3.8%	S1399 to Humboldt	XS640151>640152>\$2
635034	CLRND 5	161.0	560001	NODAWAYCO	161.0	1	153	147.4	147.7	3.8%	S1399 to Humboldt	XS640125>640127>640129\$1
635034	CLRND 5	161.0	560001	NODAWAYCO	161.0	1	153	147.4	147.7	3.8%	S1399 to Humboldt	XS640140>640446>643173\$1
635034	CLRND 5	161.0	560001	NODAWAYCO	161.0	1	153	147.4	147.7	3.8%	S1399 to Humboldt	XS640068>640246>\$1
635034	CLRND 5	161.0	560001	NODAWAYCO	161.0	1	153	147.4	147.7	3.8%	S1399 to Humboldt	XS640131>640132>643040\$2
635034	CLRND 5	161.0	560001	NODAWAYCO	161.0	1	153	147.4	147.7	3.8%	S1399 to Humboldt	XS640076>640077>\$2
635034	CLRND 5	161.0	560001	NODAWAYCO	161.0	1	153	147.4	147.7	3.8%	S1399 to Humboldt	XS640151>640263>\$1
635034	CLRND 5	161.0	560001	NODAWAYCO	161.0	1	153	147.4	147.7	3.8%	S1399 to Humboldt	XS640153>640154>\$1
635034	CLRND 5	161.0	560001	NODAWAYCO	161.0	1	153	147.4	147.7	3.8%	S1399 to Humboldt	XS636410>636415>\$1
635034	CLRND 5	161.0	560001	NODAWAYCO	161.0	1	153	147.4	147.7	3.8%	S1399 to Humboldt	XS636423>636425>\$1
635034	CLRND 5	161.0	560001	NODAWAYCO	161.0	1	153	147.4	147.7	3.8%	S1399 to Humboldt	XS640066>640224>\$1
635034	CLRND 5	161.0	560001	NODAWAYCO	161.0	1	153	147.4	147.7	3.8%	S1399 to Humboldt	XS640076>640077>\$1
635034	CLRND 5	161.0	560001	NODAWAYCO	161.0	1	153	147.4	147.7	3.8%	S1399 to Humboldt	XS636662>636665>\$1
635034	CLRND 5	161.0	560001	NODAWAYCO	161.0	1	153	147.4	147.7	3.8%	S1399 to Humboldt	XS636665>636666>\$1
635034	CLRND 5	161.0	560001	NODAWAYCO	161.0	1	153	147.4	147.7	3.8%	S1399 to Humboldt	XS640151>640152>\$1
635034	CLRND 5	161.0	560001	NODAWAYCO	161.0	1	153	147.4	147.7	3.8%	S1399 to Humboldt	XS640089>640090>\$1
635034	CLRND 5	161.0	560001	NODAWAYCO	161.0	1	153	147.4	147.7	3.8%	S1399 to Humboldt	XS640089>640090>\$2
635034	CLRND 5	161.0	560001	NODAWAYCO	161.0	1	153	147.4	147.7	3.8%	S1399 to Humboldt	XS640127>640128>\$2
635034	CLRND 5	161.0	560001	NODAWAYCO	161.0	1	153	147.4	147.7	3.8%	S1399 to Humboldt	XS640143>647973>\$1
635034	CLRND 5	161.0	560001	NODAWAYCO	161.0	1	153	147.4	147.7	3.8%	S1399 to Humboldt	XS636665>636667>\$1
635034	CLRND 5	161.0	560001	NODAWAYCO	161.0	1	153	147.4	147.7	3.8%	S1399 to Humboldt	XS640131>640132>643039\$1
635034	CLRND 5	161.0	560001	NODAWAYCO	161.0	1	153	147.4	147.7	3.8%	S1399 to Humboldt	XS636625>636628>\$1
635034	CLRND 5	161.0	560001	NODAWAYCO	161.0	1	153	147.4	147.7	3.8%	S1399 to Humboldt	XS636636>636670>\$1
635034	CLRND 5	161.0	560001	NODAWAYCO	161.0	1	153	147.4	147.7	3.8%	S1399 to Humboldt	XS640127>640128>\$1

635034	CLRND 5	161.0	560001	NODAWAYCO	161.0	1	153	147.4	147.7	3.8%	S1399 to Humboldt	XS636668>636670>\$1
635034	CLRND 5	161.0	560001	NODAWAYCO	161.0	1	153	147.4	147.7	3.8%	S1399 to Humboldt	XS636401>636423>\$1
635034	CLRND 5	161.0	560001	NODAWAYCO	161.0	1	153	147.4	147.7	3.8%	S1399 to Humboldt	XS636660>636662>\$1
635034	CLRND 5	161.0	560001	NODAWAYCO	161.0	1	153	147.4	147.7	3.8%	S1399 to Humboldt	XS640153>640154>\$2
635034	CLRND 5	161.0	560001	NODAWAYCO	161.0	1	153	147.4	147.7	3.8%	S1399 to Humboldt	XS636410>636411>\$1
635034	CLRND 5	161.0	560001	NODAWAYCO	161.0	1	153	147.4	147.7	3.8%	S1399 to Humboldt	XS636421>630679>\$1
635034	CLRND 5	161.0	560001	NODAWAYCO	161.0	1	153	147.4	147.7	3.8%	S1399 to Humboldt	XS636650>636692>\$1
635034	CLRND 5	161.0	560001	NODAWAYCO	161.0	1	153	147.4	147.7	3.8%	S1399 to Humboldt	XS636401>636403>\$1
635034	CLRND 5	161.0	560001	NODAWAYCO	161.0	1	153	147.4	147.7	3.8%	S1399 to Humboldt	XS636683>636685>\$1
635034	CLRND 5	161.0	560001	NODAWAYCO	161.0	1	153	147.4	147.7	3.8%	S1399 to Humboldt	XS636682>636683>\$1
635034	CLRND 5	161.0	560001	NODAWAYCO	161.0	1	153	147.4	147.7	3.8%	S1399 to Humboldt	XS640113>640305>\$1
635034	CLRND 5	161.0	560001	NODAWAYCO	161.0	1	153	147.4	147.7	3.8%	S1399 to Humboldt	XS640054>640055>\$2
635034	CLRND 5	161.0	560001	NODAWAYCO	161.0	1	153	147.4	147.7	3.8%	S1399 to Humboldt	XS638000>638010>\$1
635034	CLRND 5	161.0	560001	NODAWAYCO	161.0	1	153	147.4	147.7	3.8%	S1399 to Humboldt	XS636605>274698>\$2
635034	CLRND 5	161.0	560001	NODAWAYCO	161.0	1	153	147.4	147.7	3.8%	S1399 to Humboldt	XS636220>636223>\$1
635034	CLRND 5	161.0	560001	NODAWAYCO	161.0	1	153	147.4	147.7	3.8%	S1399 to Humboldt	XS636685>636686>\$1
635034	CLRND 5	161.0	560001	NODAWAYCO	161.0	1	153	147.4	147.7	3.8%	S1399 to Humboldt	XS636616>636626>\$1
635034	CLRND 5	161.0	560001	NODAWAYCO	161.0	1	153	147.4	147.7	3.8%	S1399 to Humboldt	XS640054>640055>\$1
635034	CLRND 5	161.0	560001	NODAWAYCO	161.0	1	153	147.4	147.7	3.8%	S1399 to Humboldt	XS640107>640108>\$2
635034	CLRND 5	161.0	560001	NODAWAYCO	161.0	1	153	147.4	147.7	3.8%	S1399 to Humboldt	XS636670>636675>\$1
635034	CLRND 5	161.0	560001	NODAWAYCO	161.0	1	153	147.4	147.7	3.8%	S1399 to Humboldt	XS636205>636206>\$1
635034	CLRND 5	161.0	560001	NODAWAYCO	161.0	1	153	147.4	147.7	3.8%	S1399 to Humboldt	XS640107>640108>\$1
635034	CLRND 5	161.0	560001	NODAWAYCO	161.0	1	153	147.4	147.7	3.8%	S1399 to Humboldt	XS640056>640057>\$1
635034	CLRND 5	161.0	560001	NODAWAYCO	161.0	1	153	147.4	147.7	3.8%	S1399 to Humboldt	XS636205>636207>\$1
635034	CLRND 5	161.0	560001	NODAWAYCO	161.0	1	153	147.4	147.7	3.8%	S1399 to Humboldt	XS636611>636690>\$1
635034	CLRND 5	161.0	560001	NODAWAYCO	161.0	1	153	147.4	147.7	3.8%	S1399 to Humboldt	XS636680>636681>\$1
635034	CLRND 5	161.0	560001	NODAWAYCO	161.0	1	153	147.4	147.7	3.8%	S1399 to Humboldt	XS640103>640005>\$1

635034	CLRND 5	161.0	560001	NODAWAYCO	161.0	1	153	147.4	147.7	3.8%	S1399 to Humboldt	XS638050>638051>\$2
635034	CLRND 5	161.0	560001	NODAWAYCO	161.0	1	153	147.4	147.7	3.8%	S1399 to Humboldt	XS636208>638040>\$1
635034	CLRND 5	161.0	560001	NODAWAYCO	161.0	1	153	147.4	147.7	3.8%	S1399 to Humboldt	XS638050>638051>\$1
635034	CLRND 5	161.0	560001	NODAWAYCO	161.0	1	153	147.4	147.7	3.8%	S1399 to Humboldt	XS636681>636682>\$1
635034	CLRND 5	161.0	560001	NODAWAYCO	161.0	1	153	147.4	147.7	3.8%	S1399 to Humboldt	XS640103>640161>\$1
635034	CLRND 5	161.0	560001	NODAWAYCO	161.0	1	153	147.4	147.7	3.8%	S1399 to Humboldt	XS636220>636222>\$1
635034	CLRND 5	161.0	560001	NODAWAYCO	161.0	1	153	147.4	147.7	3.8%	S1399 to Humboldt	XS636605>274698>\$1
635034	CLRND 5	161.0	560001	NODAWAYCO	161.0	1	153	147.4	147.7	3.8%	S1399 to Humboldt	XS636207>636208>\$1
635034	CLRND 5	161.0	560001	NODAWAYCO	161.0	1	153	147.4	147.7	3.8%	S1399 to Humboldt	XS636208>636220>\$1
635034	CLRND 5	161.0	560001	NODAWAYCO	161.0	1	153	147.4	147.7	3.8%	S1399 to Humboldt	XS636681>636685>\$1
635034	CLRND 5	161.0	560001	NODAWAYCO	161.0	1	153	147.4	147.7	3.8%	S1399 to Humboldt	XS636601>636660>\$1
635034	CLRND 5	161.0	560001	NODAWAYCO	161.0	1	153	147.4	147.7	3.8%	S1399 to Humboldt	XS638010>638011>\$1
635034	CLRND 5	161.0	560001	NODAWAYCO	161.0	1	153	147.4	147.7	3.8%	S1399 to Humboldt	XS636611>636687>\$1
635034	CLRND 5	161.0	560001	NODAWAYCO	161.0	1	153	147.4	147.7	3.8%	S1399 to Humboldt	XS640181>640182>\$1
635034	CLRND 5	161.0	560001	NODAWAYCO	161.0	1	153	147.4	147.7	3.8%	S1399 to Humboldt	XS636686>636687>\$1
635034	CLRND 5	161.0	560001	NODAWAYCO	161.0	1	153	147.4	147.7	3.8%	S1399 to Humboldt	XS636685>636690>\$1
635034	CLRND 5	161.0	560001	NODAWAYCO	161.0	1	153	147.4	147.7	3.8%	S1399 to Humboldt	XS640056>640057>\$2
635034	CLRND 5	161.0	560001	NODAWAYCO	161.0	1	153	147.4	147.7	3.8%	S1399 to Humboldt	XS640159>642071>\$1
635034	CLRND 5	161.0	560001	NODAWAYCO	161.0	1	153	147.4	147.7	3.8%	S1399 to Humboldt	XS640105>640218>\$1
635034	CLRND 5	161.0	560001	NODAWAYCO	161.0	1	153	147.4	147.7	3.8%	S1399 to Humboldt	XS640181>640182>\$2
635034	CLRND 5	161.0	560001	NODAWAYCO	161.0	1	153	147.4	147.7	3.8%	S1399 to Humboldt	XS640119>640122>\$2
635034	CLRND 5	161.0	560001	NODAWAYCO	161.0	1	153	147.4	147.7	3.8%	S1399 to Humboldt	XS640119>640122>\$1
635034	CLRND 5	161.0	560001	NODAWAYCO	161.0	1	153	147.4	147.7	3.8%	S1399 to Humboldt	XS640119>640124>\$1
635034	CLRND 5	161.0	560001	NODAWAYCO	161.0	1	153	147.4	147.7	3.8%	S1399 to Humboldt	XS640387>640388>\$2
635034	CLRND 5	161.0	560001	NODAWAYCO	161.0	1	153	147.4	147.7	3.8%	S1399 to Humboldt	XS640292>647962>\$1
635034	CLRND 5	161.0	560001	NODAWAYCO	161.0	1	153	147.4	147.7	3.8%	S1399 to Humboldt	XS640296>640298>\$1
635034	CLRND 5	161.0	560001	NODAWAYCO	161.0	1	153	147.4	147.7	3.8%	S1399 to Humboldt	XS640298>640299>\$1

635034	CLRNDA 5 161.0	560001	NODAWAYCO 161.0	1	153	147.4	147.7	3.8%	S1399 to Humboldt	XS640224>640242>\$1
635034	CLRNDA 5 161.0	560001	NODAWAYCO 161.0	1	153	147.4	147.7	3.8%	S1399 to Humboldt	XS642066>642075>\$1
635034	CLRNDA 5 161.0	560001	NODAWAYCO 161.0	1	153	147.4	147.7	3.8%	S1399 to Humboldt	XS645113>646258>\$1
635034	CLRNDA 5 161.0	560001	NODAWAYCO 161.0	1	153	147.4	147.7	3.8%	S1399 to Humboldt	XS640387>640388>\$1
635034	CLRNDA 5 161.0	560001	NODAWAYCO 161.0	1	153	147.4	147.7	3.8%	S1399 to Humboldt	XS640228>640229>\$1
635034	CLRNDA 5 161.0	560001	NODAWAYCO 161.0	1	153	147.4	147.7	3.8%	S1399 to Humboldt	XS642066>642074>\$1
635034	CLRNDA 5 161.0	560001	NODAWAYCO 161.0	1	153	147.4	147.7	3.8%	S1399 to Humboldt	XS640387>640424>\$1
635034	CLRNDA 5 161.0	560001	NODAWAYCO 161.0	1	153	147.4	147.7	3.8%	S1399 to Humboldt	XS640224>640225>\$2
635034	CLRNDA 5 161.0	560001	NODAWAYCO 161.0	1	153	147.4	147.7	3.8%	S1399 to Humboldt	XS645114>646258>\$1
635034	CLRNDA 5 161.0	560001	NODAWAYCO 161.0	1	153	147.4	147.7	3.8%	S1399 to Humboldt	XS640238>640240>\$1
635034	CLRNDA 5 161.0	560001	NODAWAYCO 161.0	1	153	147.4	147.7	3.8%	S1399 to Humboldt	XS640296>640297>\$1
635034	CLRNDA 5 161.0	560001	NODAWAYCO 161.0	1	153	147.4	147.7	3.8%	S1399 to Humboldt	XS640336>640337>\$1
635034	CLRNDA 5 161.0	560001	NODAWAYCO 161.0	1	153	147.4	147.7	3.8%	S1399 to Humboldt	XS640386>640387>643156\$2
635034	CLRNDA 5 161.0	560001	NODAWAYCO 161.0	1	153	147.4	147.7	3.8%	S1399 to Humboldt	XS640296>640297>\$2
635034	CLRNDA 5 161.0	560001	NODAWAYCO 161.0	1	153	147.4	147.7	3.8%	S1399 to Humboldt	XS640336>640337>\$2
635034	CLRNDA 5 161.0	560001	NODAWAYCO 161.0	1	153	147.4	147.7	3.8%	S1399 to Humboldt	XS640386>640387>643155\$1
635034	CLRNDA 5 161.0	560001	NODAWAYCO 161.0	1	153	147.4	147.7	3.8%	S1399 to Humboldt	XS640298>640299>\$2
635034	CLRNDA 5 161.0	560001	NODAWAYCO 161.0	1	153	147.4	147.7	3.8%	S1399 to Humboldt	XS640228>640229>\$2
635034	CLRNDA 5 161.0	560001	NODAWAYCO 161.0	1	153	147.4	147.7	3.8%	S1399 to Humboldt	XS640234>646280>\$1
635034	CLRNDA 5 161.0	560001	NODAWAYCO 161.0	1	153	147.4	147.7	3.8%	S1399 to Humboldt	XS642069>642073>\$1
635034	CLRNDA 5 161.0	560001	NODAWAYCO 161.0	1	153	147.4	147.7	3.8%	S1399 to Humboldt	XS640269>640326>\$2
635034	CLRNDA 5 161.0	560001	NODAWAYCO 161.0	1	153	147.4	147.7	3.8%	S1399 to Humboldt	XS642070>642072>\$1
635034	CLRNDA 5 161.0	560001	NODAWAYCO 161.0	1	153	147.4	147.7	3.8%	S1399 to Humboldt	XS640275>640276>\$1
635034	CLRNDA 5 161.0	560001	NODAWAYCO 161.0	1	153	147.4	147.7	3.8%	S1399 to Humboldt	XS640278>640021>\$1
635034	CLRNDA 5 161.0	560001	NODAWAYCO 161.0	1	153	147.4	147.7	3.8%	S1399 to Humboldt	XS640347>640348>643139\$1
635034	CLRNDA 5 161.0	560001	NODAWAYCO 161.0	1	153	147.4	147.7	3.8%	S1399 to Humboldt	XS641083>641090>\$1
635034	CLRNDA 5 161.0	560001	NODAWAYCO 161.0	1	153	147.4	147.7	3.8%	S1399 to Humboldt	XS641083>641084>\$1

635034	CLRND 5	161.0	560001	NODAWAYCO	161.0	1	153	147.4	147.7	3.8%	S1399 to Humboldt	XS640261>640275>\$1
635034	CLRND 5	161.0	560001	NODAWAYCO	161.0	1	153	147.4	147.7	3.8%	S1399 to Humboldt	XS640345>640346>\$1
635034	CLRND 5	161.0	560001	NODAWAYCO	161.0	1	153	147.4	147.7	3.8%	S1399 to Humboldt	XS641082>641085>\$1
635034	CLRND 5	161.0	560001	NODAWAYCO	161.0	1	153	147.4	147.7	3.8%	S1399 to Humboldt	XS640275>640276>\$2
635034	CLRND 5	161.0	560001	NODAWAYCO	161.0	1	153	147.4	147.7	3.8%	S1399 to Humboldt	XS645115>646258>\$1
635034	CLRND 5	161.0	560001	NODAWAYCO	161.0	1	153	147.4	147.7	3.8%	S1399 to Humboldt	XS641082>641084>\$1
635034	CLRND 5	161.0	560001	NODAWAYCO	161.0	1	153	147.4	147.7	3.8%	S1399 to Humboldt	XS641085>641088>\$1
635034	CLRND 5	161.0	560001	NODAWAYCO	161.0	1	153	147.4	147.7	3.8%	S1399 to Humboldt	XS640265>640287>\$1
635034	CLRND 5	161.0	560001	NODAWAYCO	161.0	1	153	147.4	147.7	3.8%	S1399 to Humboldt	XS640183>640184>643066\$2
635034	CLRND 5	161.0	560001	NODAWAYCO	161.0	1	153	147.4	147.7	3.8%	S1399 to Humboldt	XS640347>640348>643169\$2
635034	CLRND 5	161.0	560001	NODAWAYCO	161.0	1	153	147.4	147.7	3.8%	S1399 to Humboldt	XS640183>640184>640185\$1
635034	CLRND 5	161.0	560001	NODAWAYCO	161.0	1	153	147.4	147.7	3.8%	S1399 to Humboldt	XS640345>640346>\$2
635034	CLRND 5	161.0	560001	NODAWAYCO	161.0	1	153	147.4	147.7	3.8%	S1399 to Humboldt	XS640269>640017>\$1
635034	CLRND 5	161.0	560001	NODAWAYCO	161.0	1	153	147.4	147.7	3.8%	S1399 to Humboldt	XS640269>640270>\$1
635034	CLRND 5	161.0	560001	NODAWAYCO	161.0	1	153	147.4	147.7	3.8%	S1399 to Humboldt	XS640269>640270>\$2
635034	CLRND 5	161.0	560001	NODAWAYCO	161.0	1	153	147.4	147.7	3.8%	S1399 to Humboldt	XS640269>640326>\$1
635034	CLRND 5	161.0	560001	NODAWAYCO	161.0	1	153	147.4	147.7	3.8%	S1399 to Humboldt	XS640250>640251>\$1
635034	CLRND 5	161.0	560001	NODAWAYCO	161.0	1	153	147.4	147.7	3.8%	S1399 to Humboldt	XS642066>642071>\$1
635034	CLRND 5	161.0	560001	NODAWAYCO	161.0	1	153	147.4	147.7	3.8%	S1399 to Humboldt	XS642066>642065>\$1
635034	CLRND 5	161.0	560001	NODAWAYCO	161.0	1	153	147.4	147.7	3.8%	S1399 to Humboldt	XS640338>659242>\$1
635034	CLRND 5	161.0	560001	NODAWAYCO	161.0	1	153	147.4	147.7	3.8%	S1399 to Humboldt	XS640286>640287>640291\$2
635034	CLRND 5	161.0	560001	NODAWAYCO	161.0	1	153	147.4	147.7	3.8%	S1399 to Humboldt	XS640246>652300>\$1
635034	CLRND 5	161.0	560001	NODAWAYCO	161.0	1	153	147.4	147.7	3.8%	S1399 to Humboldt	XS642066>642064>\$1
635034	CLRND 5	161.0	560001	NODAWAYCO	161.0	1	153	147.4	147.7	3.8%	S1399 to Humboldt	XS640286>640287>640290\$1
635034	CLRND 5	161.0	560001	NODAWAYCO	161.0	1	153	147.4	147.7	3.8%	S1399 to Humboldt	XS640248>640250>\$1
635034	CLRND 5	161.0	560001	NODAWAYCO	161.0	1	153	147.4	147.7	3.8%	S1399 to Humboldt	XS642068>642069>\$1
635034	CLRND 5	161.0	560001	NODAWAYCO	161.0	1	153	147.4	147.7	3.8%	S1399 to Humboldt	XS641087>641090>\$1

635034	CLRND 5	161.0	560001	NODAWAYCO	161.0	1	153	147.4	147.7	3.8%	S1399 to Humboldt	XS640253>659132>\$1
635034	CLRND 5	161.0	560001	NODAWAYCO	161.0	1	153	147.4	147.7	3.8%	S1399 to Humboldt	XS640248>640331>\$1
635034	CLRND 5	161.0	560001	NODAWAYCO	161.0	1	153	147.4	147.7	3.8%	S1399 to Humboldt	XS645116>646258>\$1
635034	CLRND 5	161.0	560001	NODAWAYCO	161.0	1	153	147.4	147.7	3.8%	S1399 to Humboldt	XS640282>641082>\$1
635034	CLRND 5	161.0	560001	NODAWAYCO	161.0	1	153	147.4	147.7	3.8%	S1399 to Humboldt	XS640250>640251>\$2
635034	CLRND 5	161.0	560001	NODAWAYCO	161.0	1	153	147.4	147.7	3.8%	S1399 to Humboldt	XS641087>641088>\$1
635034	CLRND 5	161.0	560001	NODAWAYCO	161.0	1	153	147.4	147.7	3.8%	S1399 to Humboldt	XS640351>652482>\$1
635034	CLRND 5	161.0	560001	NODAWAYCO	161.0	1	153	147.4	147.7	3.8%	S1399 to Humboldt	XS640250>640383>\$1
635034	CLRND 5	161.0	560001	NODAWAYCO	161.0	1	153	147.4	147.7	3.8%	S1399 to Humboldt	XS640252>640253>640254\$1
635034	CLRND 5	161.0	560001	NODAWAYCO	161.0	1	153	147.4	147.7	3.8%	S1399 to Humboldt	XS640340>640341>\$2
635034	CLRND 5	161.0	560001	NODAWAYCO	161.0	1	153	147.4	147.7	3.8%	S1399 to Humboldt	XS640387>640424>\$2
635034	CLRND 5	161.0	560001	NODAWAYCO	161.0	1	153	147.4	147.7	3.8%	S1399 to Humboldt	XS640340>640341>\$1
635034	CLRND 5	161.0	560001	NODAWAYCO	161.0	1	153	147.4	147.7	3.8%	S1399 to Humboldt	XS645032>647906>\$1
635034	CLRND 5	161.0	560001	NODAWAYCO	161.0	1	153	147.4	147.7	3.8%	S1399 to Humboldt	XS640215>640216>\$2
635034	CLRND 5	161.0	560001	NODAWAYCO	161.0	1	153	147.4	147.7	3.8%	S1399 to Humboldt	XS640305>640306>\$1
635034	CLRND 5	161.0	560001	NODAWAYCO	161.0	1	153	147.4	147.7	3.8%	S1399 to Humboldt	XS640330>640331>643128\$1
635034	CLRND 5	161.0	560001	NODAWAYCO	161.0	1	153	147.4	147.7	3.8%	S1399 to Humboldt	XS640200>652571>652316\$2
635034	CLRND 5	161.0	560001	NODAWAYCO	161.0	1	153	147.4	147.7	3.8%	S1399 to Humboldt	XS640305>640306>\$2
635034	CLRND 5	161.0	560001	NODAWAYCO	161.0	1	153	147.4	147.7	3.8%	S1399 to Humboldt	XS640206>640368>\$1
635034	CLRND 5	161.0	560001	NODAWAYCO	161.0	1	153	147.4	147.7	3.8%	S1399 to Humboldt	XS645052>647901>\$1
635034	CLRND 5	161.0	560001	NODAWAYCO	161.0	1	153	147.4	147.7	3.8%	S1399 to Humboldt	XS640215>641087>\$1
635034	CLRND 5	161.0	560001	NODAWAYCO	161.0	1	153	147.4	147.7	3.8%	S1399 to Humboldt	XS640215>641088>\$1
635034	CLRND 5	161.0	560001	NODAWAYCO	161.0	1	153	147.4	147.7	3.8%	S1399 to Humboldt	XS645031>647006>\$1
635034	CLRND 5	161.0	560001	NODAWAYCO	161.0	1	153	147.4	147.7	3.8%	S1399 to Humboldt	XS640215>640216>\$1
635034	CLRND 5	161.0	560001	NODAWAYCO	161.0	1	153	147.4	147.7	3.8%	S1399 to Humboldt	XS640218>640012>\$1
635034	CLRND 5	161.0	560001	NODAWAYCO	161.0	1	153	147.4	147.7	3.8%	S1399 to Humboldt	XS645051>647901>\$1
635034	CLRND 5	161.0	560001	NODAWAYCO	161.0	1	153	147.4	147.7	3.8%	S1399 to Humboldt	XS640200>652571>652314\$1

635034	CLRNDA 5	161.0	560001	NODAWAYCO	161.0	1	153	147.4	147.7	3.8%	S1399 to Humboldt	XS640224>640225>\$1
635034	CLRNDA 5	161.0	560001	NODAWAYCO	161.0	1	153	147.4	147.7	3.8%	S1399 to Humboldt	XS646251>646298>\$1
635034	CLRNDA 5	161.0	560001	NODAWAYCO	161.0	1	153	147.4	147.7	3.8%	S1399 to Humboldt	XS647909>647918>\$1
635034	CLRNDA 5	161.0	560001	NODAWAYCO	161.0	1	153	147.4	147.7	3.8%	S1399 to Humboldt	XS650290>650093>\$1
635034	CLRNDA 5	161.0	560001	NODAWAYCO	161.0	1	153	147.4	147.7	3.8%	S1399 to Humboldt	XS650185>650285>650485\$2
635034	CLRNDA 5	161.0	560001	NODAWAYCO	161.0	1	153	147.4	147.7	3.8%	S1399 to Humboldt	XS650267>650367>\$2
635034	CLRNDA 5	161.0	560001	NODAWAYCO	161.0	1	153	147.4	147.7	3.8%	S1399 to Humboldt	XS647424>647425>\$1
635034	CLRNDA 5	161.0	560001	NODAWAYCO	161.0	1	153	147.4	147.7	3.8%	S1399 to Humboldt	XS647102>647103>\$1
635034	CLRNDA 5	161.0	560001	NODAWAYCO	161.0	1	153	147.4	147.7	3.8%	S1399 to Humboldt	XS647909>647921>\$1
635034	CLRNDA 5	161.0	560001	NODAWAYCO	161.0	1	153	147.4	147.7	3.8%	S1399 to Humboldt	XS650267>650367>\$1
635034	CLRNDA 5	161.0	560001	NODAWAYCO	161.0	1	153	147.4	147.7	3.8%	S1399 to Humboldt	XS652300>659238>\$1
635034	CLRNDA 5	161.0	560001	NODAWAYCO	161.0	1	153	147.4	147.7	3.8%	S1399 to Humboldt	XS650270>650271>\$1
635034	CLRNDA 5	161.0	560001	NODAWAYCO	161.0	1	153	147.4	147.7	3.8%	S1399 to Humboldt	XS647006>647017>\$1
635034	CLRNDA 5	161.0	560001	NODAWAYCO	161.0	1	153	147.4	147.7	3.8%	S1399 to Humboldt	XS647908>647910>\$1
635034	CLRNDA 5	161.0	560001	NODAWAYCO	161.0	1	153	147.4	147.7	3.8%	S1399 to Humboldt	XS650218>650238>\$1
635034	CLRNDA 5	161.0	560001	NODAWAYCO	161.0	1	153	147.4	147.7	3.8%	S1399 to Humboldt	XS652312>659242>\$1
635034	CLRNDA 5	161.0	560001	NODAWAYCO	161.0	1	153	147.4	147.7	3.8%	S1399 to Humboldt	XS647918>647930>\$1
635034	CLRNDA 5	161.0	560001	NODAWAYCO	161.0	1	153	147.4	147.7	3.8%	S1399 to Humboldt	XS650214>650290>\$1
635034	CLRNDA 5	161.0	560001	NODAWAYCO	161.0	1	153	147.4	147.7	3.8%	S1399 to Humboldt	XS650250>650255>\$1
635034	CLRNDA 5	161.0	560001	NODAWAYCO	161.0	1	153	147.4	147.7	3.8%	S1399 to Humboldt	XS650217>650219>\$1
635034	CLRNDA 5	161.0	560001	NODAWAYCO	161.0	1	153	147.4	147.7	3.8%	S1399 to Humboldt	XS650242>650290>\$1
635034	CLRNDA 5	161.0	560001	NODAWAYCO	161.0	1	153	147.4	147.7	3.8%	S1399 to Humboldt	XS650185>650285>650385\$1
635034	CLRNDA 5	161.0	560001	NODAWAYCO	161.0	1	153	147.4	147.7	3.8%	S1399 to Humboldt	XS650218>650230>\$1
635034	CLRNDA 5	161.0	560001	NODAWAYCO	161.0	1	153	147.4	147.7	3.8%	S1399 to Humboldt	XS650267>650285>\$1
635034	CLRNDA 5	161.0	560001	NODAWAYCO	161.0	1	153	147.4	147.7	3.8%	S1399 to Humboldt	XS647090>647971>\$1
635034	CLRNDA 5	161.0	560001	NODAWAYCO	161.0	1	153	147.4	147.7	3.8%	S1399 to Humboldt	XS647114>647962>\$1
635034	CLRNDA 5	161.0	560001	NODAWAYCO	161.0	1	153	147.4	147.7	3.8%	S1399 to Humboldt	XS646237>646253>\$1

635034	CLRND 5	161.0	560001	NODAWAYCO	161.0	1	153	147.4	147.7	3.8%	S1399 to Humboldt	XS647107>647994>\$1
635034	CLRND 5	161.0	560001	NODAWAYCO	161.0	1	153	147.4	147.7	3.8%	S1399 to Humboldt	XS646236>646345>\$1
635034	CLRND 5	161.0	560001	NODAWAYCO	161.0	1	153	147.4	147.7	3.8%	S1399 to Humboldt	XS647421>647426>\$1
635034	CLRND 5	161.0	560001	NODAWAYCO	161.0	1	153	147.4	147.7	3.8%	S1399 to Humboldt	XS646251>646341>\$1
635034	CLRND 5	161.0	560001	NODAWAYCO	161.0	1	153	147.4	147.7	3.8%	S1399 to Humboldt	XS647017>647108>\$1
635034	CLRND 5	161.0	560001	NODAWAYCO	161.0	1	153	147.4	147.7	3.8%	S1399 to Humboldt	XS647016>647107>\$1
635034	CLRND 5	161.0	560001	NODAWAYCO	161.0	1	153	147.4	147.7	3.8%	S1399 to Humboldt	XS647938>647995>\$1
635034	CLRND 5	161.0	560001	NODAWAYCO	161.0	1	153	147.4	147.7	3.8%	S1399 to Humboldt	XS650229>650250>\$1
635034	CLRND 5	161.0	560001	NODAWAYCO	161.0	1	153	147.4	147.7	3.8%	S1399 to Humboldt	XS647114>647971>\$1
635034	CLRND 5	161.0	560001	NODAWAYCO	161.0	1	153	147.4	147.7	3.8%	S1399 to Humboldt	XS647108>647994>\$1
635034	CLRND 5	161.0	560001	NODAWAYCO	161.0	1	153	147.4	147.7	3.8%	S1399 to Humboldt	XS650208>650230>\$1
635034	CLRND 5	161.0	560001	NODAWAYCO	161.0	1	153	147.4	147.7	3.8%	S1399 to Humboldt	XS650275>650283>\$1
635034	CLRND 5	161.0	560001	NODAWAYCO	161.0	1	153	147.4	147.7	3.8%	S1399 to Humboldt	XS647912>647923>\$1
635034	CLRND 5	161.0	560001	NODAWAYCO	161.0	1	153	147.4	147.7	3.8%	S1399 to Humboldt	XS650208>650308>\$2
635034	CLRND 5	161.0	560001	NODAWAYCO	161.0	1	153	147.4	147.7	3.8%	S1399 to Humboldt	XS647994>647995>\$1
635034	CLRND 5	161.0	560001	NODAWAYCO	161.0	1	153	147.4	147.7	3.8%	S1399 to Humboldt	XS650256>650257>\$1
635034	CLRND 5	161.0	560001	NODAWAYCO	161.0	1	153	147.4	147.7	3.8%	S1399 to Humboldt	XS646226>646298>\$1
635034	CLRND 5	161.0	560001	NODAWAYCO	161.0	1	153	147.4	147.7	3.8%	S1399 to Humboldt	XS650208>650308>\$3
635034	CLRND 5	161.0	560001	NODAWAYCO	161.0	1	153	147.4	147.7	3.8%	S1399 to Humboldt	XS647016>647906>\$1
635034	CLRND 5	161.0	560001	NODAWAYCO	161.0	1	153	147.4	147.7	3.8%	S1399 to Humboldt	XS652398>652399>\$1
635034	CLRND 5	161.0	560001	NODAWAYCO	161.0	1	153	147.4	147.7	3.8%	S1399 to Humboldt	XS650290>650091>\$1
635034	CLRND 5	161.0	560001	NODAWAYCO	161.0	1	153	147.4	147.7	3.8%	S1399 to Humboldt	XS650230>650238>\$1
635034	CLRND 5	161.0	560001	NODAWAYCO	161.0	1	153	147.4	147.7	3.8%	S1399 to Humboldt	XS646226>646298>\$2
635034	CLRND 5	161.0	560001	NODAWAYCO	161.0	1	153	147.4	147.7	3.8%	S1399 to Humboldt	XS646210>647910>648210\$1
635034	CLRND 5	161.0	560001	NODAWAYCO	161.0	1	153	147.4	147.7	3.8%	S1399 to Humboldt	XS646305>646341>\$1
635034	CLRND 5	161.0	560001	NODAWAYCO	161.0	1	153	147.4	147.7	3.8%	S1399 to Humboldt	XS647902>647983>\$1
635034	CLRND 5	161.0	560001	NODAWAYCO	161.0	1	153	147.4	147.7	3.8%	S1399 to Humboldt	XS650238>650258>\$1

635034	CLRNDA 5	161.0	560001	NODAWAYCO	161.0	1	153	147.4	147.7	3.8%	S1399 to Humboldt	XS647101>647963>\$1
635034	CLRNDA 5	161.0	560001	NODAWAYCO	161.0	1	153	147.4	147.7	3.8%	S1399 to Humboldt	XS647015>647017>\$1
635034	CLRNDA 5	161.0	560001	NODAWAYCO	161.0	1	153	147.4	147.7	3.8%	S1399 to Humboldt	XS647411>647427>\$1
635034	CLRNDA 5	161.0	560001	NODAWAYCO	161.0	1	153	147.4	147.7	3.8%	S1399 to Humboldt	XS646235>646253>\$1
635034	CLRNDA 5	161.0	560001	NODAWAYCO	161.0	1	153	147.4	147.7	3.8%	S1399 to Humboldt	XS646298>646305>\$1
635034	CLRNDA 5	161.0	560001	NODAWAYCO	161.0	1	153	147.4	147.7	3.8%	S1399 to Humboldt	XS300077>344179>\$1
635034	CLRNDA 5	161.0	560001	NODAWAYCO	161.0	1	153	147.4	147.7	3.8%	S1399 to Humboldt	XS300079>344586>\$1
635034	CLRNDA 5	161.0	560001	NODAWAYCO	161.0	1	153	147.4	147.7	3.8%	S1399 to Humboldt	XS300055>300609>\$1
635034	CLRNDA 5	161.0	560001	NODAWAYCO	161.0	1	153	147.4	147.7	3.8%	S1399 to Humboldt	XS300074>301136>\$1
635034	CLRNDA 5	161.0	560001	NODAWAYCO	161.0	1	153	147.4	147.7	3.8%	S1399 to Humboldt	XS300037>300604>\$1
635034	CLRNDA 5	161.0	560001	NODAWAYCO	161.0	1	153	147.4	147.7	3.8%	S1399 to Humboldt	XS300057>344026>\$1
635034	CLRNDA 5	161.0	560001	NODAWAYCO	161.0	1	153	147.4	147.7	3.8%	S1399 to Humboldt	XS300089>300348>\$1
635034	CLRNDA 5	161.0	560001	NODAWAYCO	161.0	1	153	147.4	147.7	3.8%	S1399 to Humboldt	XS300089>300678>\$1
635034	CLRNDA 5	161.0	560001	NODAWAYCO	161.0	1	153	147.4	147.7	3.8%	S1399 to Humboldt	XS300064>301044>\$1
635034	CLRNDA 5	161.0	560001	NODAWAYCO	161.0	1	153	147.4	147.7	3.8%	S1399 to Humboldt	XS300089>300726>\$1
635034	CLRNDA 5	161.0	560001	NODAWAYCO	161.0	1	153	147.4	147.7	3.8%	S1399 to Humboldt	XS300075>300029>\$1
635034	CLRNDA 5	161.0	560001	NODAWAYCO	161.0	1	153	147.4	147.7	3.8%	S1399 to Humboldt	XS300046>300103>\$1
635034	CLRNDA 5	161.0	560001	NODAWAYCO	161.0	1	153	147.4	147.7	3.8%	S1399 to Humboldt	XS300046>300103>\$2
635034	CLRNDA 5	161.0	560001	NODAWAYCO	161.0	1	153	147.4	147.7	3.8%	S1399 to Humboldt	XS300090>300517>\$2
635034	CLRNDA 5	161.0	560001	NODAWAYCO	161.0	1	153	147.4	147.7	3.8%	S1399 to Humboldt	XS300053>300096>\$1
635034	CLRNDA 5	161.0	560001	NODAWAYCO	161.0	1	153	147.4	147.7	3.8%	S1399 to Humboldt	XS300090>300517>\$3
635034	CLRNDA 5	161.0	560001	NODAWAYCO	161.0	1	153	147.4	147.7	3.8%	S1399 to Humboldt	XS300074>301149>\$1
635034	CLRNDA 5	161.0	560001	NODAWAYCO	161.0	1	153	147.4	147.7	3.8%	S1399 to Humboldt	XS300077>345511>\$1
635034	CLRNDA 5	161.0	560001	NODAWAYCO	161.0	1	153	147.4	147.7	3.8%	S1399 to Humboldt	XS300059>300099>\$1
635034	CLRNDA 5	161.0	560001	NODAWAYCO	161.0	1	153	147.4	147.7	3.8%	S1399 to Humboldt	XS300084>505438>\$1
635034	CLRNDA 5	161.0	560001	NODAWAYCO	161.0	1	153	147.4	147.7	3.8%	S1399 to Humboldt	XS300053>345024>\$1
635034	CLRNDA 5	161.0	560001	NODAWAYCO	161.0	1	153	147.4	147.7	3.8%	S1399 to Humboldt	XS300084>301207>\$1

635034	CLRND 5	161.0	560001	NODAWAYCO	161.0	1	153	147.4	147.7	3.8%	S1399 to Humboldt	XS300067>300111>\$1
635034	CLRND 5	161.0	560001	NODAWAYCO	161.0	1	153	147.4	147.7	3.8%	S1399 to Humboldt	XS300060>300100>\$1
635034	CLRND 5	161.0	560001	NODAWAYCO	161.0	1	153	147.4	147.7	3.8%	S1399 to Humboldt	S1221 AUTOV3
635034	CLRND 5	161.0	560001	NODAWAYCO	161.0	1	153	147.4	147.7	3.8%	S1399 to Humboldt	XS300099>300575>\$1
635034	CLRND 5	161.0	560001	NODAWAYCO	161.0	1	153	147.4	147.7	3.8%	S1399 to Humboldt	XS300059>345542>\$1
635034	CLRND 5	161.0	560001	NODAWAYCO	161.0	1	153	147.4	147.7	3.8%	S1399 to Humboldt	XS300065>301059>\$1
635034	CLRND 5	161.0	560001	NODAWAYCO	161.0	1	153	147.4	147.7	3.8%	S1399 to Humboldt	XS300069>512648>\$1
635034	CLRND 5	161.0	560001	NODAWAYCO	161.0	1	153	147.4	147.7	3.8%	S1399 to Humboldt	XS300096>300643>\$1
635034	CLRND 5	161.0	560001	NODAWAYCO	161.0	1	153	147.4	147.7	3.8%	S1399 to Humboldt	XS300095>301128>\$1
635034	CLRND 5	161.0	560001	NODAWAYCO	161.0	1	153	147.4	147.7	3.8%	S1399 to Humboldt	XS300099>300100>\$1
635034	CLRND 5	161.0	560001	NODAWAYCO	161.0	1	153	147.4	147.7	3.8%	S1399 to Humboldt	XS300068>300194>\$1
635034	CLRND 5	161.0	560001	NODAWAYCO	161.0	1	153	147.4	147.7	3.8%	S1399 to Humboldt	XS300124>300013>\$2
635034	CLRND 5	161.0	560001	NODAWAYCO	161.0	1	153	147.4	147.7	3.8%	S1399 to Humboldt	XS532937>533021>532959\$1
635034	CLRND 5	161.0	560001	NODAWAYCO	161.0	1	153	147.4	147.7	3.8%	S1399 to Humboldt	XS532861>533326>532888\$1
635034	CLRND 5	161.0	560001	NODAWAYCO	161.0	1	153	147.4	147.7	3.8%	S1399 to Humboldt	XS300137>300140>\$1
635034	CLRND 5	161.0	560001	NODAWAYCO	161.0	1	153	147.4	147.7	3.8%	S1399 to Humboldt	XS300138>300996>\$1
635034	CLRND 5	161.0	560001	NODAWAYCO	161.0	1	153	147.4	147.7	3.8%	S1399 to Humboldt	XS300608>300609>\$1
635034	CLRND 5	161.0	560001	NODAWAYCO	161.0	1	153	147.4	147.7	3.8%	S1399 to Humboldt	XS532791>532986>532821\$1
635034	CLRND 5	161.0	560001	NODAWAYCO	161.0	1	153	147.4	147.7	3.8%	S1399 to Humboldt	XS532857>533182>532886\$1
635034	CLRND 5	161.0	560001	NODAWAYCO	161.0	1	153	147.4	147.7	3.8%	S1399 to Humboldt	XS532791>532986>532822\$1
635034	CLRND 5	161.0	560001	NODAWAYCO	161.0	1	153	147.4	147.7	3.8%	S1399 to Humboldt	XS532937>533021>532958\$1
635034	CLRND 5	161.0	560001	NODAWAYCO	161.0	1	153	147.4	147.7	3.8%	S1399 to Humboldt	XS300124>300012>\$1
635034	CLRND 5	161.0	560001	NODAWAYCO	161.0	1	153	147.4	147.7	3.8%	S1399 to Humboldt	XS300138>300140>\$1
635034	CLRND 5	161.0	560001	NODAWAYCO	161.0	1	153	147.4	147.7	3.8%	S1399 to Humboldt	XS300122>301114>\$1
635034	CLRND 5	161.0	560001	NODAWAYCO	161.0	1	153	147.4	147.7	3.8%	S1399 to Humboldt	XS300123>505448>\$1
635034	CLRND 5	161.0	560001	NODAWAYCO	161.0	1	153	147.4	147.7	3.8%	S1399 to Humboldt	XS532934>543065>\$1
635034	CLRND 5	161.0	560001	NODAWAYCO	161.0	1	153	147.4	147.7	3.8%	S1399 to Humboldt	XS300593>345091>\$1

635034	CLRNDA 5	161.0	560001	NODAWAYCO	161.0	1	153	147.4	147.7	3.8%	S1399 to Humboldt	XS300104>300025>\$1
635034	CLRNDA 5	161.0	560001	NODAWAYCO	161.0	1	153	147.4	147.7	3.8%	S1399 to Humboldt	XS300122>301114>\$2
635034	CLRNDA 5	161.0	560001	NODAWAYCO	161.0	1	153	147.4	147.7	3.8%	S1399 to Humboldt	XS300168>300173>\$2
635034	CLRNDA 5	161.0	560001	NODAWAYCO	161.0	1	153	147.4	147.7	3.8%	S1399 to Humboldt	XS300137>521026>\$1
635034	CLRNDA 5	161.0	560001	NODAWAYCO	161.0	1	153	147.4	147.7	3.8%	S1399 to Humboldt	XS300104>300026>\$2
635034	CLRNDA 5	161.0	560001	NODAWAYCO	161.0	1	153	147.4	147.7	3.8%	S1399 to Humboldt	XS300678>505492>\$1
635034	CLRNDA 5	161.0	560001	NODAWAYCO	161.0	1	153	147.4	147.7	3.8%	S1399 to Humboldt	XS300121>345790>\$1
635034	CLRNDA 5	161.0	560001	NODAWAYCO	161.0	1	153	147.4	147.7	3.8%	S1399 to Humboldt	XS532771>532796>\$1
635034	CLRNDA 5	161.0	560001	NODAWAYCO	161.0	1	153	147.4	147.7	3.8%	S1399 to Humboldt	XS300606>344449>\$1
635034	CLRNDA 5	161.0	560001	NODAWAYCO	161.0	1	153	147.4	147.7	3.8%	S1399 to Humboldt	XS300596>300612>\$1
635034	CLRNDA 5	161.0	560001	NODAWAYCO	161.0	1	153	147.4	147.7	3.8%	S1399 to Humboldt	XS532796>533040>532829\$1
635034	CLRNDA 5	161.0	560001	NODAWAYCO	161.0	1	153	147.4	147.7	3.8%	S1399 to Humboldt	XS300111>300643>\$1
635034	CLRNDA 5	161.0	560001	NODAWAYCO	161.0	1	153	147.4	147.7	3.8%	S1399 to Humboldt	XS532932>532934>\$1
635034	CLRNDA 5	161.0	560001	NODAWAYCO	161.0	1	153	147.4	147.7	3.8%	S1399 to Humboldt	XS300339>300363>\$1
635034	CLRNDA 5	161.0	560001	NODAWAYCO	161.0	1	153	147.4	147.7	3.8%	S1399 to Humboldt	XS300112>301149>\$1
635034	CLRNDA 5	161.0	560001	NODAWAYCO	161.0	1	153	147.4	147.7	3.8%	S1399 to Humboldt	XS300726>300805>\$1
635034	CLRNDA 5	161.0	560001	NODAWAYCO	161.0	1	153	147.4	147.7	3.8%	S1399 to Humboldt	XS300118>547605>547719\$1
635034	CLRNDA 5	161.0	560001	NODAWAYCO	161.0	1	153	147.4	147.7	3.8%	S1399 to Humboldt	XS532771>533416>532810\$1
635034	CLRNDA 5	161.0	560001	NODAWAYCO	161.0	1	153	147.4	147.7	3.8%	S1399 to Humboldt	XS300600>300612>\$1
635034	CLRNDA 5	161.0	560001	NODAWAYCO	161.0	1	153	147.4	147.7	3.8%	S1399 to Humboldt	XS300348>549954>\$1
635034	CLRNDA 5	161.0	560001	NODAWAYCO	161.0	1	153	147.4	147.7	3.8%	S1399 to Humboldt	XS532926>532932>\$1
635034	CLRNDA 5	161.0	560001	NODAWAYCO	161.0	1	153	147.4	147.7	3.8%	S1399 to Humboldt	XS300168>300173>\$1
635034	CLRNDA 5	161.0	560001	NODAWAYCO	161.0	1	153	147.4	147.7	3.8%	S1399 to Humboldt	XS300113>300339>\$1
635034	CLRNDA 5	161.0	560001	NODAWAYCO	161.0	1	153	147.4	147.7	3.8%	S1399 to Humboldt	XS300480>300597>\$1
635034	CLRNDA 5	161.0	560001	NODAWAYCO	161.0	1	153	147.4	147.7	3.8%	S1399 to Humboldt	XS532926>532937>\$1
635034	CLRNDA 5	161.0	560001	NODAWAYCO	161.0	1	153	147.4	147.7	3.8%	S1399 to Humboldt	XS300766>300767>\$1
635034	CLRNDA 5	161.0	560001	NODAWAYCO	161.0	1	153	147.4	147.7	3.8%	S1399 to Humboldt	XS300131>300140>\$1

635034	CLRNDA 5 161.0	560001	NODAWAYCO 161.0	1	153	147.4	147.7	3.8%	S1399 to Humboldt	XS300480>345091>\$1
635034	CLRNDA 5 161.0	560001	NODAWAYCO 161.0	1	153	147.4	147.7	3.8%	S1399 to Humboldt	XS300124>300014>\$3
635034	CLRNDA 5 161.0	560001	NODAWAYCO 161.0	1	153	147.4	147.7	3.8%	S1399 to Humboldt	XS301342>300689>\$1
635034	CLRNDA 5 161.0	560001	NODAWAYCO 161.0	1	153	147.4	147.7	3.8%	S1399 to Humboldt	XS300756>338200>\$1
635034	CLRNDA 5 161.0	560001	NODAWAYCO 161.0	1	153	147.4	147.7	3.8%	S1399 to Humboldt	XS532774>532856>532815\$1
635034	CLRNDA 5 161.0	560001	NODAWAYCO 161.0	1	153	147.4	147.7	3.8%	S1399 to Humboldt	XS300139>300929>\$1
635034	CLRNDA 5 161.0	560001	NODAWAYCO 161.0	1	153	147.4	147.7	3.8%	S1399 to Humboldt	XS300844>512712>\$1
635034	CLRNDA 5 161.0	560001	NODAWAYCO 161.0	1	153	147.4	147.7	3.8%	S1399 to Humboldt	XS300996>301339>\$1
635034	CLRNDA 5 161.0	560001	NODAWAYCO 161.0	1	153	147.4	147.7	3.8%	S1399 to Humboldt	XS300766>512704>\$1
635034	CLRNDA 5 161.0	560001	NODAWAYCO 161.0	1	153	147.4	147.7	3.8%	S1399 to Humboldt	XS300130>300805>\$1
635034	CLRNDA 5 161.0	560001	NODAWAYCO 161.0	1	153	147.4	147.7	3.8%	S1399 to Humboldt	XS532796>533040>532830\$1
635034	CLRNDA 5 161.0	560001	NODAWAYCO 161.0	1	153	147.4	147.7	3.8%	S1399 to Humboldt	XS532774>532856>532819\$2
635034	CLRNDA 5 161.0	560001	NODAWAYCO 161.0	1	153	147.4	147.7	3.8%	S1399 to Humboldt	XS532856>532857>\$1
635034	CLRNDA 5 161.0	560001	NODAWAYCO 161.0	1	153	147.4	147.7	3.8%	S1399 to Humboldt	XS300766>512655>\$1
635034	CLRNDA 5 161.0	560001	NODAWAYCO 161.0	1	153	147.4	147.7	3.8%	S1399 to Humboldt	XS300139>510377>\$1
635034	CLRNDA 5 161.0	560001	NODAWAYCO 161.0	1	153	147.4	147.7	3.8%	S1399 to Humboldt	XS533189>533190>\$1
635034	CLRNDA 5 161.0	560001	NODAWAYCO 161.0	1	153	147.4	147.7	3.8%	S1399 to Humboldt	XS533044>533045>\$1
635034	CLRNDA 5 161.0	560001	NODAWAYCO 161.0	1	153	147.4	147.7	3.8%	S1399 to Humboldt	XS533234>533252>\$1
635034	CLRNDA 5 161.0	560001	NODAWAYCO 161.0	1	153	147.4	147.7	3.8%	S1399 to Humboldt	XS533361>532681>\$1
635034	CLRNDA 5 161.0	560001	NODAWAYCO 161.0	1	153	147.4	147.7	3.8%	S1399 to Humboldt	XS533361>533365>\$1
635034	CLRNDA 5 161.0	560001	NODAWAYCO 161.0	1	153	147.4	147.7	3.8%	S1399 to Humboldt	XS533361>533371>\$2
635034	CLRNDA 5 161.0	560001	NODAWAYCO 161.0	1	153	147.4	147.7	3.8%	S1399 to Humboldt	XS533323>533362>\$1
635034	CLRNDA 5 161.0	560001	NODAWAYCO 161.0	1	153	147.4	147.7	3.8%	S1399 to Humboldt	XS532991>533026>\$1
635034	CLRNDA 5 161.0	560001	NODAWAYCO 161.0	1	153	147.4	147.7	3.8%	S1399 to Humboldt	XS533039>533068>\$1
635034	CLRNDA 5 161.0	560001	NODAWAYCO 161.0	1	153	147.4	147.7	3.8%	S1399 to Humboldt	XS533361>533371>\$1
635034	CLRNDA 5 161.0	560001	NODAWAYCO 161.0	1	153	147.4	147.7	3.8%	S1399 to Humboldt	XS533265>533273>\$1
635034	CLRNDA 5 161.0	560001	NODAWAYCO 161.0	1	153	147.4	147.7	3.8%	S1399 to Humboldt	XS533326>533334>\$1

635034	CLRNDA 5	161.0	560001	NODAWAYCO	161.0	1	153	147.4	147.7	3.8%	S1399 to Humboldt	XS533211>533216>\$1
635034	CLRNDA 5	161.0	560001	NODAWAYCO	161.0	1	153	147.4	147.7	3.8%	S1399 to Humboldt	XS533321>533342>\$1
635034	CLRNDA 5	161.0	560001	NODAWAYCO	161.0	1	153	147.4	147.7	3.8%	S1399 to Humboldt	XS533013>533429>533096\$1
635034	CLRNDA 5	161.0	560001	NODAWAYCO	161.0	1	153	147.4	147.7	3.8%	S1399 to Humboldt	XS533043>533064>\$1
635034	CLRNDA 5	161.0	560001	NODAWAYCO	161.0	1	153	147.4	147.7	3.8%	S1399 to Humboldt	XS533361>533886>\$2
635034	CLRNDA 5	161.0	560001	NODAWAYCO	161.0	1	153	147.4	147.7	3.8%	S1399 to Humboldt	XS533361>533365>\$2
635034	CLRNDA 5	161.0	560001	NODAWAYCO	161.0	1	153	147.4	147.7	3.8%	S1399 to Humboldt	XS533310>533311>\$1
635034	CLRNDA 5	161.0	560001	NODAWAYCO	161.0	1	153	147.4	147.7	3.8%	S1399 to Humboldt	XS533328>533343>\$2
635034	CLRNDA 5	161.0	560001	NODAWAYCO	161.0	1	153	147.4	147.7	3.8%	S1399 to Humboldt	XS533175>533185>\$1
635034	CLRNDA 5	161.0	560001	NODAWAYCO	161.0	1	153	147.4	147.7	3.8%	S1399 to Humboldt	XS533216>533259>\$1
635034	CLRNDA 5	161.0	560001	NODAWAYCO	161.0	1	153	147.4	147.7	3.8%	S1399 to Humboldt	XS533011>533013>\$1
635034	CLRNDA 5	161.0	560001	NODAWAYCO	161.0	1	153	147.4	147.7	3.8%	S1399 to Humboldt	XS533041>532723>\$1
635034	CLRNDA 5	161.0	560001	NODAWAYCO	161.0	1	153	147.4	147.7	3.8%	S1399 to Humboldt	XS533301>533309>\$1
635034	CLRNDA 5	161.0	560001	NODAWAYCO	161.0	1	153	147.4	147.7	3.8%	S1399 to Humboldt	XS533040>532729>\$1
635034	CLRNDA 5	161.0	560001	NODAWAYCO	161.0	1	153	147.4	147.7	3.8%	S1399 to Humboldt	XS533176>533195>\$1
635034	CLRNDA 5	161.0	560001	NODAWAYCO	161.0	1	153	147.4	147.7	3.8%	S1399 to Humboldt	XS533174>533461>533447\$1
635034	CLRNDA 5	161.0	560001	NODAWAYCO	161.0	1	153	147.4	147.7	3.8%	S1399 to Humboldt	XS533307>533309>\$1
635034	CLRNDA 5	161.0	560001	NODAWAYCO	161.0	1	153	147.4	147.7	3.8%	S1399 to Humboldt	XS533339>533340>\$1
635034	CLRNDA 5	161.0	560001	NODAWAYCO	161.0	1	153	147.4	147.7	3.8%	S1399 to Humboldt	XS533335>533340>\$1
635034	CLRNDA 5	161.0	560001	NODAWAYCO	161.0	1	153	147.4	147.7	3.8%	S1399 to Humboldt	XS533305>533309>\$1
635034	CLRNDA 5	161.0	560001	NODAWAYCO	161.0	1	153	147.4	147.7	3.8%	S1399 to Humboldt	XS533040>533041>\$1
635034	CLRNDA 5	161.0	560001	NODAWAYCO	161.0	1	153	147.4	147.7	3.8%	S1399 to Humboldt	XS533178>533190>\$2
635034	CLRNDA 5	161.0	560001	NODAWAYCO	161.0	1	153	147.4	147.7	3.8%	S1399 to Humboldt	XS533304>533307>\$1
635034	CLRNDA 5	161.0	560001	NODAWAYCO	161.0	1	153	147.4	147.7	3.8%	S1399 to Humboldt	XS533178>533190>\$1
635034	CLRNDA 5	161.0	560001	NODAWAYCO	161.0	1	153	147.4	147.7	3.8%	S1399 to Humboldt	XS533333>533334>\$1
635034	CLRNDA 5	161.0	560001	NODAWAYCO	161.0	1	153	147.4	147.7	3.8%	S1399 to Humboldt	XS533037>533060>\$1
635034	CLRNDA 5	161.0	560001	NODAWAYCO	161.0	1	153	147.4	147.7	3.8%	S1399 to Humboldt	XS533216>533475>533450\$1

635034	CLRND 5	161.0	560001	NODAWAYCO	161.0	1	153	147.4	147.7	3.8%	S1399 to Humboldt	XS533273>533283>\$1
635034	CLRND 5	161.0	560001	NODAWAYCO	161.0	1	153	147.4	147.7	3.8%	S1399 to Humboldt	XS533167>533339>\$1
635034	CLRND 5	161.0	560001	NODAWAYCO	161.0	1	153	147.4	147.7	3.8%	S1399 to Humboldt	XS533004>533006>\$1
635034	CLRND 5	161.0	560001	NODAWAYCO	161.0	1	153	147.4	147.7	3.8%	S1399 to Humboldt	XS532991>533032>\$1
635034	CLRND 5	161.0	560001	NODAWAYCO	161.0	1	153	147.4	147.7	3.8%	S1399 to Humboldt	XS533167>533339>\$2
635034	CLRND 5	161.0	560001	NODAWAYCO	161.0	1	153	147.4	147.7	3.8%	S1399 to Humboldt	XS533211>533268>\$1
635034	CLRND 5	161.0	560001	NODAWAYCO	161.0	1	153	147.4	147.7	3.8%	S1399 to Humboldt	XS533211>533471>533449\$1
635034	CLRND 5	161.0	560001	NODAWAYCO	161.0	1	153	147.4	147.7	3.8%	S1399 to Humboldt	XS533344>533362>\$1
635034	CLRND 5	161.0	560001	NODAWAYCO	161.0	1	153	147.4	147.7	3.8%	S1399 to Humboldt	XS533002>533003>\$1
635034	CLRND 5	161.0	560001	NODAWAYCO	161.0	1	153	147.4	147.7	3.8%	S1399 to Humboldt	XS533035>533064>\$1
635034	CLRND 5	161.0	560001	NODAWAYCO	161.0	1	153	147.4	147.7	3.8%	S1399 to Humboldt	XS533301>533304>\$1
635034	CLRND 5	161.0	560001	NODAWAYCO	161.0	1	153	147.4	147.7	3.8%	S1399 to Humboldt	XS533268>533272>\$1
635034	CLRND 5	161.0	560001	NODAWAYCO	161.0	1	153	147.4	147.7	3.8%	S1399 to Humboldt	XS533041>533053>\$1
635034	CLRND 5	161.0	560001	NODAWAYCO	161.0	1	153	147.4	147.7	3.8%	S1399 to Humboldt	XS533180>533192>\$1
635034	CLRND 5	161.0	560001	NODAWAYCO	161.0	1	153	147.4	147.7	3.8%	S1399 to Humboldt	XS533004>533698>533091\$1
635034	CLRND 5	161.0	560001	NODAWAYCO	161.0	1	153	147.4	147.7	3.8%	S1399 to Humboldt	XS533278>533283>\$1
635034	CLRND 5	161.0	560001	NODAWAYCO	161.0	1	153	147.4	147.7	3.8%	S1399 to Humboldt	XS533328>533343>\$1
635034	CLRND 5	161.0	560001	NODAWAYCO	161.0	1	153	147.4	147.7	3.8%	S1399 to Humboldt	XS533339>533340>\$2
635034	CLRND 5	161.0	560001	NODAWAYCO	161.0	1	153	147.4	147.7	3.8%	S1399 to Humboldt	XS533172>533186>\$1
635034	CLRND 5	161.0	560001	NODAWAYCO	161.0	1	153	147.4	147.7	3.8%	S1399 to Humboldt	XS533220>533484>533451\$1
635034	CLRND 5	161.0	560001	NODAWAYCO	161.0	1	153	147.4	147.7	3.8%	S1399 to Humboldt	XS533041>532724>\$1
635034	CLRND 5	161.0	560001	NODAWAYCO	161.0	1	153	147.4	147.7	3.8%	S1399 to Humboldt	XS533335>533340>\$2
635034	CLRND 5	161.0	560001	NODAWAYCO	161.0	1	153	147.4	147.7	3.8%	S1399 to Humboldt	XS533024>533060>\$1
635034	CLRND 5	161.0	560001	NODAWAYCO	161.0	1	153	147.4	147.7	3.8%	S1399 to Humboldt	XS533373>533378>\$2
635034	CLRND 5	161.0	560001	NODAWAYCO	161.0	1	153	147.4	147.7	3.8%	S1399 to Humboldt	XS533158>533195>\$1
635034	CLRND 5	161.0	560001	NODAWAYCO	161.0	1	153	147.4	147.7	3.8%	S1399 to Humboldt	XS533159>533168>\$1
635034	CLRND 5	161.0	560001	NODAWAYCO	161.0	1	153	147.4	147.7	3.8%	S1399 to Humboldt	XS533032>533039>\$1

635034	CLRND 5	161.0	560001	NODAWAYCO	161.0	1	153	147.4	147.7	3.8%	S1399 to Humboldt	XS533046>532739>\$1
635034	CLRND 5	161.0	560001	NODAWAYCO	161.0	1	153	147.4	147.7	3.8%	S1399 to Humboldt	XS533029>533039>\$1
635034	CLRND 5	161.0	560001	NODAWAYCO	161.0	1	153	147.4	147.7	3.8%	S1399 to Humboldt	XS532986>533037>\$1
635034	CLRND 5	161.0	560001	NODAWAYCO	161.0	1	153	147.4	147.7	3.8%	S1399 to Humboldt	XS533151>533167>\$1
635034	CLRND 5	161.0	560001	NODAWAYCO	161.0	1	153	147.4	147.7	3.8%	S1399 to Humboldt	XS533259>533266>\$1
635034	CLRND 5	161.0	560001	NODAWAYCO	161.0	1	153	147.4	147.7	3.8%	S1399 to Humboldt	XS533370>533371>\$1
635034	CLRND 5	161.0	560001	NODAWAYCO	161.0	1	153	147.4	147.7	3.8%	S1399 to Humboldt	XS533159>533184>\$1
635034	CLRND 5	161.0	560001	NODAWAYCO	161.0	1	153	147.4	147.7	3.8%	S1399 to Humboldt	XS533239>533255>\$1
635034	CLRND 5	161.0	560001	NODAWAYCO	161.0	1	153	147.4	147.7	3.8%	S1399 to Humboldt	XS533060>533822>533110\$1
635034	CLRND 5	161.0	560001	NODAWAYCO	161.0	1	153	147.4	147.7	3.8%	S1399 to Humboldt	XS533045>533072>\$1
635034	CLRND 5	161.0	560001	NODAWAYCO	161.0	1	153	147.4	147.7	3.8%	S1399 to Humboldt	XS533250>533253>\$1
635034	CLRND 5	161.0	560001	NODAWAYCO	161.0	1	153	147.4	147.7	3.8%	S1399 to Humboldt	XS533259>533268>\$1
635034	CLRND 5	161.0	560001	NODAWAYCO	161.0	1	153	147.4	147.7	3.8%	S1399 to Humboldt	XS533033>533043>\$1
635034	CLRND 5	161.0	560001	NODAWAYCO	161.0	1	153	147.4	147.7	3.8%	S1399 to Humboldt	XS533151>533167>\$2
635034	CLRND 5	161.0	560001	NODAWAYCO	161.0	1	153	147.4	147.7	3.8%	S1399 to Humboldt	XS533159>533174>\$1
635034	CLRND 5	161.0	560001	NODAWAYCO	161.0	1	153	147.4	147.7	3.8%	S1399 to Humboldt	XS533048>533066>\$1
635034	CLRND 5	161.0	560001	NODAWAYCO	161.0	1	153	147.4	147.7	3.8%	S1399 to Humboldt	XS533153>533192>\$2
635034	CLRND 5	161.0	560001	NODAWAYCO	161.0	1	153	147.4	147.7	3.8%	S1399 to Humboldt	XS533049>533051>\$1
635034	CLRND 5	161.0	560001	NODAWAYCO	161.0	1	153	147.4	147.7	3.8%	S1399 to Humboldt	XS533242>533272>\$1
635034	CLRND 5	161.0	560001	NODAWAYCO	161.0	1	153	147.4	147.7	3.8%	S1399 to Humboldt	XS533153>533192>\$1
635034	CLRND 5	161.0	560001	NODAWAYCO	161.0	1	153	147.4	147.7	3.8%	S1399 to Humboldt	XS532985>532992>\$1
635034	CLRND 5	161.0	560001	NODAWAYCO	161.0	1	153	147.4	147.7	3.8%	S1399 to Humboldt	XS533021>533768>533100\$1
635034	CLRND 5	161.0	560001	NODAWAYCO	161.0	1	153	147.4	147.7	3.8%	S1399 to Humboldt	XS533370>533376>\$2
635034	CLRND 5	161.0	560001	NODAWAYCO	161.0	1	153	147.4	147.7	3.8%	S1399 to Humboldt	XS533049>533053>\$1
635034	CLRND 5	161.0	560001	NODAWAYCO	161.0	1	153	147.4	147.7	3.8%	S1399 to Humboldt	XS533021>533768>533099\$1
635034	CLRND 5	161.0	560001	NODAWAYCO	161.0	1	153	147.4	147.7	3.8%	S1399 to Humboldt	XS533021>533768>533100\$2
635034	CLRND 5	161.0	560001	NODAWAYCO	161.0	1	153	147.4	147.7	3.8%	S1399 to Humboldt	XS533370>533376>\$1

635034	CLRNDA 5 161.0	560001	NODAWAYCO 161.0	1	153	147.4	147.7	3.8%	S1399 to Humboldt	XS533046>533795>533106\$1
635034	CLRNDA 5 161.0	560001	NODAWAYCO 161.0	1	153	147.4	147.7	3.8%	S1399 to Humboldt	XS532986>533024>\$1
635034	CLRNDA 5 161.0	560001	NODAWAYCO 161.0	1	153	147.4	147.7	3.8%	S1399 to Humboldt	XS533370>533371>\$2
635034	CLRNDA 5 161.0	560001	NODAWAYCO 161.0	1	153	147.4	147.7	3.8%	S1399 to Humboldt	XS533029>533046>\$1
635034	CLRNDA 5 161.0	560001	NODAWAYCO 161.0	1	153	147.4	147.7	3.8%	S1399 to Humboldt	XS533021>533768>532711\$1
635034	CLRNDA 5 161.0	560001	NODAWAYCO 161.0	1	153	147.4	147.7	3.8%	S1399 to Humboldt	XS533153>533162>\$1
635034	CLRNDA 5 161.0	560001	NODAWAYCO 161.0	1	153	147.4	147.7	3.8%	S1399 to Humboldt	XS533158>533173>\$1
635034	CLRNDA 5 161.0	560001	NODAWAYCO 161.0	1	153	147.4	147.7	3.8%	S1399 to Humboldt	XS533257>533271>\$1
635034	CLRNDA 5 161.0	560001	NODAWAYCO 161.0	1	153	147.4	147.7	3.8%	S1399 to Humboldt	XS533373>533378>\$1
635034	CLRNDA 5 161.0	560001	NODAWAYCO 161.0	1	153	147.4	147.7	3.8%	S1399 to Humboldt	XS533153>533182>\$1
635034	CLRNDA 5 161.0	560001	NODAWAYCO 161.0	1	153	147.4	147.7	3.8%	S1399 to Humboldt	XS532987>533583>\$1
635034	CLRNDA 5 161.0	560001	NODAWAYCO 161.0	1	153	147.4	147.7	3.8%	S1399 to Humboldt	XS533026>533060>\$1
635034	CLRNDA 5 161.0	560001	NODAWAYCO 161.0	1	153	147.4	147.7	3.8%	S1399 to Humboldt	XS533162>533168>\$1
635034	CLRNDA 5 161.0	560001	NODAWAYCO 161.0	1	153	147.4	147.7	3.8%	S1399 to Humboldt	XS533364>533376>\$1
635034	CLRNDA 5 161.0	560001	NODAWAYCO 161.0	1	153	147.4	147.7	3.8%	S1399 to Humboldt	XS532987>533001>\$1
635034	CLRNDA 5 161.0	560001	NODAWAYCO 161.0	1	153	147.4	147.7	3.8%	S1399 to Humboldt	XS533162>533166>\$1
635034	CLRNDA 5 161.0	560001	NODAWAYCO 161.0	1	153	147.4	147.7	3.8%	S1399 to Humboldt	XS533060>533822>533111\$1
635034	CLRNDA 5 161.0	560001	NODAWAYCO 161.0	1	153	147.4	147.7	3.8%	S1399 to Humboldt	XS533378>533379>\$1
635034	CLRNDA 5 161.0	560001	NODAWAYCO 161.0	1	153	147.4	147.7	3.8%	S1399 to Humboldt	XS533028>533048>\$1
635034	CLRNDA 5 161.0	560001	NODAWAYCO 161.0	1	153	147.4	147.7	3.8%	S1399 to Humboldt	XS533160>533189>\$1
635034	CLRNDA 5 161.0	560001	NODAWAYCO 161.0	1	153	147.4	147.7	3.8%	S1399 to Humboldt	XS533239>533278>\$1
635034	CLRNDA 5 161.0	560001	NODAWAYCO 161.0	1	153	147.4	147.7	3.8%	S1399 to Humboldt	XS533248>533250>\$1
635034	CLRNDA 5 161.0	560001	NODAWAYCO 161.0	1	153	147.4	147.7	3.8%	S1399 to Humboldt	XS652550>619975>\$1
635034	CLRNDA 5 161.0	560001	NODAWAYCO 161.0	1	153	147.4	147.7	3.8%	S1399 to Humboldt	XS652550>602007>\$1
635034	CLRNDA 5 161.0	560001	NODAWAYCO 161.0	1	153	147.4	147.7	3.8%	S1399 to Humboldt	XS652512>652534>\$1
635034	CLRNDA 5 161.0	560001	NODAWAYCO 161.0	1	153	147.4	147.7	3.8%	S1399 to Humboldt	XS652512>652535>\$1
635034	CLRNDA 5 161.0	560001	NODAWAYCO 161.0	1	153	147.4	147.7	3.8%	S1399 to Humboldt	XS652522>652326>\$1

635034	CLRND 5	161.0	560001	NODAWAYCO	161.0	1	153	147.4	147.7	3.8%	S1399 to Humboldt	XS652501>652249>\$2
635034	CLRND 5	161.0	560001	NODAWAYCO	161.0	1	153	147.4	147.7	3.8%	S1399 to Humboldt	XS652515>660009>\$1
635034	CLRND 5	161.0	560001	NODAWAYCO	161.0	1	153	147.4	147.7	3.8%	S1399 to Humboldt	XS652537>601031>\$1
635034	CLRND 5	161.0	560001	NODAWAYCO	161.0	1	153	147.4	147.7	3.8%	S1399 to Humboldt	XS652531>658094>\$1
635034	CLRND 5	161.0	560001	NODAWAYCO	161.0	1	153	147.4	147.7	3.8%	S1399 to Humboldt	XS659244>659245>\$1
635034	CLRND 5	161.0	560001	NODAWAYCO	161.0	1	153	147.4	147.7	3.8%	S1399 to Humboldt	XS652514>652515>652282\$2
635034	CLRND 5	161.0	560001	NODAWAYCO	161.0	1	153	147.4	147.7	3.8%	S1399 to Humboldt	XS652515>652528>\$1
635034	CLRND 5	161.0	560001	NODAWAYCO	161.0	1	153	147.4	147.7	3.8%	S1399 to Humboldt	XS659152>652479>\$1
635034	CLRND 5	161.0	560001	NODAWAYCO	161.0	1	153	147.4	147.7	3.8%	S1399 to Humboldt	XS652500>652504>\$1
635034	CLRND 5	161.0	560001	NODAWAYCO	161.0	1	153	147.4	147.7	3.8%	S1399 to Humboldt	XS652515>652535>\$1
635034	CLRND 5	161.0	560001	NODAWAYCO	161.0	1	153	147.4	147.7	3.8%	S1399 to Humboldt	XS652532>652288>\$1
635034	CLRND 5	161.0	560001	NODAWAYCO	161.0	1	153	147.4	147.7	3.8%	S1399 to Humboldt	XS652515>660003>\$1
635034	CLRND 5	161.0	560001	NODAWAYCO	161.0	1	153	147.4	147.7	3.8%	S1399 to Humboldt	XS652528>659123>\$1
635034	CLRND 5	161.0	560001	NODAWAYCO	161.0	1	153	147.4	147.7	3.8%	S1399 to Humboldt	XS652511>660006>\$1
635034	CLRND 5	161.0	560001	NODAWAYCO	161.0	1	153	147.4	147.7	3.8%	S1399 to Humboldt	XS652507>652276>\$2
635034	CLRND 5	161.0	560001	NODAWAYCO	161.0	1	153	147.4	147.7	3.8%	S1399 to Humboldt	XS652550>652551>652292\$1
635034	CLRND 5	161.0	560001	NODAWAYCO	161.0	1	153	147.4	147.7	3.8%	S1399 to Humboldt	XS652519>652520>\$1
635034	CLRND 5	161.0	560001	NODAWAYCO	161.0	1	153	147.4	147.7	3.8%	S1399 to Humboldt	XS652537>601031>\$2
635034	CLRND 5	161.0	560001	NODAWAYCO	161.0	1	153	147.4	147.7	3.8%	S1399 to Humboldt	XS652530>652531>652240\$1
635034	CLRND 5	161.0	560001	NODAWAYCO	161.0	1	153	147.4	147.7	3.8%	S1399 to Humboldt	XS652513>652278>\$1
635034	CLRND 5	161.0	560001	NODAWAYCO	161.0	1	153	147.4	147.7	3.8%	S1399 to Humboldt	XS652523>652524>652232\$1
635034	CLRND 5	161.0	560001	NODAWAYCO	161.0	1	153	147.4	147.7	3.8%	S1399 to Humboldt	XS652525>660006>\$1
635034	CLRND 5	161.0	560001	NODAWAYCO	161.0	1	153	147.4	147.7	3.8%	S1399 to Humboldt	XS652582>652604>652605\$1
635034	CLRND 5	161.0	560001	NODAWAYCO	161.0	1	153	147.4	147.7	3.8%	S1399 to Humboldt	XS652504>652531>\$1
635034	CLRND 5	161.0	560001	NODAWAYCO	161.0	1	153	147.4	147.7	3.8%	S1399 to Humboldt	XS652513>652279>\$1
635034	CLRND 5	161.0	560001	NODAWAYCO	161.0	1	153	147.4	147.7	3.8%	S1399 to Humboldt	XS652501>652518>\$1
635034	CLRND 5	161.0	560001	NODAWAYCO	161.0	1	153	147.4	147.7	3.8%	S1399 to Humboldt	XS652570>659236>\$1

635034	CLRND 5	161.0	560001	NODAWAYCO	161.0	1	153	147.4	147.7	3.8%	S1399 to Humboldt	XS652512>652250>\$1
635034	CLRND 5	161.0	560001	NODAWAYCO	161.0	1	153	147.4	147.7	3.8%	S1399 to Humboldt	XS652530>652531>652239\$1
635034	CLRND 5	161.0	560001	NODAWAYCO	161.0	1	153	147.4	147.7	3.8%	S1399 to Humboldt	XS652523>652524>652233\$1
635034	CLRND 5	161.0	560001	NODAWAYCO	161.0	1	153	147.4	147.7	3.8%	S1399 to Humboldt	XS652518>652252>\$1
635034	CLRND 5	161.0	560001	NODAWAYCO	161.0	1	153	147.4	147.7	3.8%	S1399 to Humboldt	XS659193>659239>\$1
635034	CLRND 5	161.0	560001	NODAWAYCO	161.0	1	153	147.4	147.7	3.8%	S1399 to Humboldt	XS652512>652250>\$2
635034	CLRND 5	161.0	560001	NODAWAYCO	161.0	1	153	147.4	147.7	3.8%	S1399 to Humboldt	XS652531>658088>\$1
635034	CLRND 5	161.0	560001	NODAWAYCO	161.0	1	153	147.4	147.7	3.8%	S1399 to Humboldt	XS652550>652551>652297\$1
635034	CLRND 5	161.0	560001	NODAWAYCO	161.0	1	153	147.4	147.7	3.8%	S1399 to Humboldt	XS652507>652276>\$1
635034	CLRND 5	161.0	560001	NODAWAYCO	161.0	1	153	147.4	147.7	3.8%	S1399 to Humboldt	XS652514>652515>652281\$1
635034	CLRND 5	161.0	560001	NODAWAYCO	161.0	1	153	147.4	147.7	3.8%	S1399 to Humboldt	XS652398>652523>\$1
635034	CLRND 5	161.0	560001	NODAWAYCO	161.0	1	153	147.4	147.7	3.8%	S1399 to Humboldt	XS652482>652264>\$1
635034	CLRND 5	161.0	560001	NODAWAYCO	161.0	1	153	147.4	147.7	3.8%	S1399 to Humboldt	XS652504>652474>\$1
635034	CLRND 5	161.0	560001	NODAWAYCO	161.0	1	153	147.4	147.7	3.8%	S1399 to Humboldt	XS659185>659186>\$1
635034	CLRND 5	161.0	560001	NODAWAYCO	161.0	1	153	147.4	147.7	3.8%	S1399 to Humboldt	XS652501>652249>\$1
635034	CLRND 5	161.0	560001	NODAWAYCO	161.0	1	153	147.4	147.7	3.8%	S1399 to Humboldt	CB1235-34&53
635034	CLRND 5	161.0	560001	NODAWAYCO	161.0	1	153	147.4	147.7	3.8%	S1399 to Humboldt	LES9003
635034	CLRND 5	161.0	560001	NODAWAYCO	161.0	1	153	147.4	147.7	3.8%	S1399 to Humboldt	BASE CASE
635034	CLRND 5	161.0	560001	NODAWAYCO	161.0	1	153	147.4	147.7	3.8%	S1399 to Humboldt	LES9002
635034	CLRND 5	161.0	560001	NODAWAYCO	161.0	1	153	147.4	147.7	3.8%	S1399 to Humboldt	D-CIRCUIT#8B
635034	CLRND 5	161.0	560001	NODAWAYCO	161.0	1	153	147.4	147.7	3.8%	S1399 to Humboldt	LES3801B
635034	CLRND 5	161.0	560001	NODAWAYCO	161.0	1	153	147.4	147.7	3.8%	S1399 to Humboldt	LES7001
635034	CLRND 5	161.0	560001	NODAWAYCO	161.0	1	153	147.4	147.7	3.8%	S1399 to Humboldt	CB994-BUS
635034	CLRND 5	161.0	560001	NODAWAYCO	161.0	1	153	147.4	147.7	3.8%	S1399 to Humboldt	CB1298-51&26
635034	CLRND 5	161.0	560001	NODAWAYCO	161.0	1	153	147.4	147.7	3.8%	S1399 to Humboldt	LES3004B
635034	CLRND 5	161.0	560001	NODAWAYCO	161.0	1	153	147.4	147.7	3.8%	S1399 to Humboldt	LES7504
635034	CLRND 5	161.0	560001	NODAWAYCO	161.0	1	153	147.4	147.7	3.8%	S1399 to Humboldt	CB1298-05&26

635034	CLRND 5	161.0	560001	NODAWAYCO	161.0	1	153	147.4	147.7	3.8%	S1399 to Humboldt	XS542969>541341>\$1
635034	CLRND 5	161.0	560001	NODAWAYCO	161.0	1	153	147.4	147.7	3.8%	S1399 to Humboldt	XS533413>533421>\$1
635034	CLRND 5	161.0	560001	NODAWAYCO	161.0	1	153	147.4	147.7	3.8%	S1399 to Humboldt	XS533421>532696>\$1
635034	CLRND 5	161.0	560001	NODAWAYCO	161.0	1	153	147.4	147.7	3.8%	S1399 to Humboldt	XS543019>543025>\$1
635034	CLRND 5	161.0	560001	NODAWAYCO	161.0	1	153	147.4	147.7	3.8%	S1399 to Humboldt	XS542966>543105>\$1
635034	CLRND 5	161.0	560001	NODAWAYCO	161.0	1	153	147.4	147.7	3.8%	S1399 to Humboldt	XS542985>543637>\$1
635034	CLRND 5	161.0	560001	NODAWAYCO	161.0	1	153	147.4	147.7	3.8%	S1399 to Humboldt	XS543017>543026>\$1
635034	CLRND 5	161.0	560001	NODAWAYCO	161.0	1	153	147.4	147.7	3.8%	S1399 to Humboldt	XS541250>541263>\$1
635034	CLRND 5	161.0	560001	NODAWAYCO	161.0	1	153	147.4	147.7	3.8%	S1399 to Humboldt	XS541250>541263>\$2
635034	CLRND 5	161.0	560001	NODAWAYCO	161.0	1	153	147.4	147.7	3.8%	S1399 to Humboldt	XS542987>542989>\$1
635034	CLRND 5	161.0	560001	NODAWAYCO	161.0	1	153	147.4	147.7	3.8%	S1399 to Humboldt	XS543020>541248>\$1
635034	CLRND 5	161.0	560001	NODAWAYCO	161.0	1	153	147.4	147.7	3.8%	S1399 to Humboldt	XS541341>541165>\$1
635034	CLRND 5	161.0	560001	NODAWAYCO	161.0	1	153	147.4	147.7	3.8%	S1399 to Humboldt	XS533428>532702>\$1
635034	CLRND 5	161.0	560001	NODAWAYCO	161.0	1	153	147.4	147.7	3.8%	S1399 to Humboldt	XS542997>543009>\$1
635034	CLRND 5	161.0	560001	NODAWAYCO	161.0	1	153	147.4	147.7	3.8%	S1399 to Humboldt	XS542993>543008>\$1
635034	CLRND 5	161.0	560001	NODAWAYCO	161.0	1	153	147.4	147.7	3.8%	S1399 to Humboldt	XS533428>532703>\$1
635034	CLRND 5	161.0	560001	NODAWAYCO	161.0	1	153	147.4	147.7	3.8%	S1399 to Humboldt	XS541224>541282>\$1
635034	CLRND 5	161.0	560001	NODAWAYCO	161.0	1	153	147.4	147.7	3.8%	S1399 to Humboldt	XS541210>541287>\$1
635034	CLRND 5	161.0	560001	NODAWAYCO	161.0	1	153	147.4	147.7	3.8%	S1399 to Humboldt	XS542993>543010>\$1
635034	CLRND 5	161.0	560001	NODAWAYCO	161.0	1	153	147.4	147.7	3.8%	S1399 to Humboldt	XS541341>541166>\$1
635034	CLRND 5	161.0	560001	NODAWAYCO	161.0	1	153	147.4	147.7	3.8%	S1399 to Humboldt	XS533428>532704>\$1
635034	CLRND 5	161.0	560001	NODAWAYCO	161.0	1	153	147.4	147.7	3.8%	S1399 to Humboldt	XS541341>541167>\$1
635034	CLRND 5	161.0	560001	NODAWAYCO	161.0	1	153	147.4	147.7	3.8%	S1399 to Humboldt	XS541341>541343>\$1
635034	CLRND 5	161.0	560001	NODAWAYCO	161.0	1	153	147.4	147.7	3.8%	S1399 to Humboldt	XS533428>533438>\$1
635034	CLRND 5	161.0	560001	NODAWAYCO	161.0	1	153	147.4	147.7	3.8%	S1399 to Humboldt	XS533426>532705>\$1
635034	CLRND 5	161.0	560001	NODAWAYCO	161.0	1	153	147.4	147.7	3.8%	S1399 to Humboldt	XS542988>542989>\$1
635034	CLRND 5	161.0	560001	NODAWAYCO	161.0	1	153	147.4	147.7	3.8%	S1399 to Humboldt	XS542988>542989>\$2

635034	CLRND 5	161.0	560001	NODAWAYCO	161.0	1	153	147.4	147.7	3.8%	S1399 to Humboldt	XS533421>532698>\$1
635034	CLRND 5	161.0	560001	NODAWAYCO	161.0	1	153	147.4	147.7	3.8%	S1399 to Humboldt	XS542988>542990>\$1
635034	CLRND 5	161.0	560001	NODAWAYCO	161.0	1	153	147.3	147.7	3.8%	S1399 to Humboldt	XS542989>542991>\$1
635034	CLRND 5	161.0	560001	NODAWAYCO	161.0	1	153	147.4	147.7	3.8%	S1399 to Humboldt	XS541225>541280>\$1
635034	CLRND 5	161.0	560001	NODAWAYCO	161.0	1	153	147.4	147.7	3.8%	S1399 to Humboldt	XS533426>533438>\$1
635034	CLRND 5	161.0	560001	NODAWAYCO	161.0	1	153	147.4	147.7	3.8%	S1399 to Humboldt	XS541209>300082>\$1
635034	CLRND 5	161.0	560001	NODAWAYCO	161.0	1	153	147.4	147.7	3.8%	S1399 to Humboldt	XS533439>530620>\$1
635034	CLRND 5	161.0	560001	NODAWAYCO	161.0	1	153	147.4	147.7	3.8%	S1399 to Humboldt	XS533421>532697>\$1
635034	CLRND 5	161.0	560001	NODAWAYCO	161.0	1	153	147.4	147.7	3.8%	S1399 to Humboldt	XS542987>543636>\$1
635034	CLRND 5	161.0	560001	NODAWAYCO	161.0	1	153	147.4	147.7	3.8%	S1399 to Humboldt	XS543034>543047>\$1
635034	CLRND 5	161.0	560001	NODAWAYCO	161.0	1	153	147.4	147.7	3.8%	S1399 to Humboldt	XS543032>543047>\$1
635034	CLRND 5	161.0	560001	NODAWAYCO	161.0	1	153	147.4	147.7	3.8%	S1399 to Humboldt	XS533416>533438>\$1
635034	CLRND 5	161.0	560001	NODAWAYCO	161.0	1	153	147.4	147.7	3.8%	S1399 to Humboldt	XS542982>541350>541150\$11
635034	CLRND 5	161.0	560001	NODAWAYCO	161.0	1	153	147.4	147.7	3.8%	S1399 to Humboldt	XS541222>541246>\$1
635034	CLRND 5	161.0	560001	NODAWAYCO	161.0	1	153	147.4	147.7	3.8%	S1399 to Humboldt	XS542985>542971>542970\$1
635034	CLRND 5	161.0	560001	NODAWAYCO	161.0	1	153	147.4	147.7	3.8%	S1399 to Humboldt	XS542985>542984>542983\$1
635034	CLRND 5	161.0	560001	NODAWAYCO	161.0	1	153	147.4	147.7	3.8%	S1399 to Humboldt	XS541230>541260>\$1
635034	CLRND 5	161.0	560001	NODAWAYCO	161.0	1	153	147.4	147.7	3.8%	S1399 to Humboldt	XS542973>542997>\$1
635034	CLRND 5	161.0	560001	NODAWAYCO	161.0	1	153	147.4	147.7	3.8%	S1399 to Humboldt	XS533414>533415>\$1
635034	CLRND 5	161.0	560001	NODAWAYCO	161.0	1	153	147.4	147.7	3.8%	S1399 to Humboldt	XS541219>541220>\$1
635034	CLRND 5	161.0	560001	NODAWAYCO	161.0	1	153	147.4	147.7	3.8%	S1399 to Humboldt	XS541200>541225>541361\$1
635034	CLRND 5	161.0	560001	NODAWAYCO	161.0	1	153	147.4	147.7	3.8%	S1399 to Humboldt	XS542985>542975>542974\$1
635034	CLRND 5	161.0	560001	NODAWAYCO	161.0	1	153	147.4	147.7	3.8%	S1399 to Humboldt	XS542985>542989>\$1
635034	CLRND 5	161.0	560001	NODAWAYCO	161.0	1	153	147.4	147.7	3.8%	S1399 to Humboldt	XS543033>543051>\$1
635034	CLRND 5	161.0	560001	NODAWAYCO	161.0	1	153	147.4	147.7	3.8%	S1399 to Humboldt	XS542985>542959>542958\$1
635034	CLRND 5	161.0	560001	NODAWAYCO	161.0	1	153	147.4	147.7	3.8%	S1399 to Humboldt	XS631039>630064>\$1
635034	CLRND 5	161.0	560001	NODAWAYCO	161.0	1	153	147.4	147.7	3.8%	S1399 to Humboldt	XS543071>543072>\$1

635034	CLRND 5	161.0	560001	NODAWAYCO	161.0	1	153	147.4	147.7	3.8%	S1399 to Humboldt	XS631064>630005>\$1
635034	CLRND 5	161.0	560001	NODAWAYCO	161.0	1	153	147.4	147.7	3.8%	S1399 to Humboldt	XS631009>631028>\$1
635034	CLRND 5	161.0	560001	NODAWAYCO	161.0	1	153	147.4	147.7	3.8%	S1399 to Humboldt	XS631017>629085>\$1
635034	CLRND 5	161.0	560001	NODAWAYCO	161.0	1	153	147.4	147.7	3.8%	S1399 to Humboldt	XS631011>629114>\$2
635034	CLRND 5	161.0	560001	NODAWAYCO	161.0	1	153	147.4	147.7	3.8%	S1399 to Humboldt	XS631043>630096>\$1
635034	CLRND 5	161.0	560001	NODAWAYCO	161.0	1	153	147.4	147.7	3.8%	S1399 to Humboldt	XS613420>630249>\$1
635034	CLRND 5	161.0	560001	NODAWAYCO	161.0	1	153	147.4	147.7	3.8%	S1399 to Humboldt	XS631044>630129>\$1
635034	CLRND 5	161.0	560001	NODAWAYCO	161.0	1	153	147.4	147.7	3.8%	S1399 to Humboldt	XS631066>681520>\$1
635034	CLRND 5	161.0	560001	NODAWAYCO	161.0	1	153	147.4	147.7	3.8%	S1399 to Humboldt	XS631066>629116>\$1
635034	CLRND 5	161.0	560001	NODAWAYCO	161.0	1	153	147.4	147.7	3.8%	S1399 to Humboldt	XS631008>631009>\$1
635034	CLRND 5	161.0	560001	NODAWAYCO	161.0	1	153	147.4	147.7	3.8%	S1399 to Humboldt	XS631066>629117>\$1
635034	CLRND 5	161.0	560001	NODAWAYCO	161.0	1	153	147.4	147.7	3.8%	S1399 to Humboldt	XS631011>629114>\$1
635034	CLRND 5	161.0	560001	NODAWAYCO	161.0	1	153	147.4	147.7	3.8%	S1399 to Humboldt	XS631008>656301>\$1
635034	CLRND 5	161.0	560001	NODAWAYCO	161.0	1	153	147.4	147.7	3.8%	S1399 to Humboldt	XS631010>631079>\$3
635034	CLRND 5	161.0	560001	NODAWAYCO	161.0	1	153	147.4	147.7	3.8%	S1399 to Humboldt	XS631046>631122>\$1
635034	CLRND 5	161.0	560001	NODAWAYCO	161.0	1	153	147.4	147.7	3.8%	S1399 to Humboldt	XS631010>631079>\$2
635034	CLRND 5	161.0	560001	NODAWAYCO	161.0	1	153	147.4	147.7	3.8%	S1399 to Humboldt	XS631046>631123>\$1
635034	CLRND 5	161.0	560001	NODAWAYCO	161.0	1	153	147.4	147.7	3.8%	S1399 to Humboldt	XS631047>630198>\$1
635034	CLRND 5	161.0	560001	NODAWAYCO	161.0	1	153	147.4	147.7	3.8%	S1399 to Humboldt	XS631047>630197>\$1
635034	CLRND 5	161.0	560001	NODAWAYCO	161.0	1	153	147.4	147.7	3.8%	S1399 to Humboldt	XS631044>631127>\$1
635034	CLRND 5	161.0	560001	NODAWAYCO	161.0	1	153	147.4	147.7	3.8%	S1399 to Humboldt	XS543112>543078>\$1
635034	CLRND 5	161.0	560001	NODAWAYCO	161.0	1	153	147.4	147.7	3.8%	S1399 to Humboldt	XS631064>630005>\$2
635034	CLRND 5	161.0	560001	NODAWAYCO	161.0	1	153	147.4	147.7	3.8%	S1399 to Humboldt	XS631041>630081>\$1
635034	CLRND 5	161.0	560001	NODAWAYCO	161.0	1	153	147.4	147.7	3.8%	S1399 to Humboldt	XS543105>543106>\$1
635034	CLRND 5	161.0	560001	NODAWAYCO	161.0	1	153	147.4	147.7	3.8%	S1399 to Humboldt	XS631016>629086>\$2
635034	CLRND 5	161.0	560001	NODAWAYCO	161.0	1	153	147.4	147.7	3.8%	S1399 to Humboldt	XS543105>543107>\$1
635034	CLRND 5	161.0	560001	NODAWAYCO	161.0	1	153	147.4	147.7	3.8%	S1399 to Humboldt	XS631080>631088>\$1

635034	CLRNDA 5 161.0	560001	NODAWAYCO 161.0	1	153	147.4	147.7	3.8%	S1399 to Humboldt	XS631016>629086>\$1
635034	CLRNDA 5 161.0	560001	NODAWAYCO 161.0	1	153	147.4	147.7	3.8%	S1399 to Humboldt	XS543105>543108>\$1
635034	CLRNDA 5 161.0	560001	NODAWAYCO 161.0	1	153	147.4	147.7	3.8%	S1399 to Humboldt	XS631041>631138>\$1
635034	CLRNDA 5 161.0	560001	NODAWAYCO 161.0	1	153	147.4	147.7	3.8%	S1399 to Humboldt	XS543105>543109>\$1
635034	CLRNDA 5 161.0	560001	NODAWAYCO 161.0	1	153	147.4	147.7	3.8%	S1399 to Humboldt	XS631041>631138>\$2
635034	CLRNDA 5 161.0	560001	NODAWAYCO 161.0	1	153	147.4	147.7	3.8%	S1399 to Humboldt	XS631043>602003>\$1
635034	CLRNDA 5 161.0	560001	NODAWAYCO 161.0	1	153	147.4	147.7	3.8%	S1399 to Humboldt	XS543636>543637>\$1
635034	CLRNDA 5 161.0	560001	NODAWAYCO 161.0	1	153	147.4	147.7	3.8%	S1399 to Humboldt	XS631065>630004>\$1
635034	CLRNDA 5 161.0	560001	NODAWAYCO 161.0	1	153	147.4	147.7	3.8%	S1399 to Humboldt	XS631014>629100>\$2
635034	CLRNDA 5 161.0	560001	NODAWAYCO 161.0	1	153	147.4	147.7	3.8%	S1399 to Humboldt	XS631017>629085>\$2
635034	CLRNDA 5 161.0	560001	NODAWAYCO 161.0	1	153	147.4	147.7	3.8%	S1399 to Humboldt	XS631014>629100>\$1
635034	CLRNDA 5 161.0	560001	NODAWAYCO 161.0	1	153	147.4	147.7	3.8%	S1399 to Humboldt	XS631039>630064>\$2
635034	CLRNDA 5 161.0	560001	NODAWAYCO 161.0	1	153	147.4	147.7	3.8%	S1399 to Humboldt	XS631050>630257>\$1
635034	CLRNDA 5 161.0	560001	NODAWAYCO 161.0	1	153	147.4	147.7	3.8%	S1399 to Humboldt	XS631064>636667>\$1
635034	CLRNDA 5 161.0	560001	NODAWAYCO 161.0	1	153	147.4	147.7	3.8%	S1399 to Humboldt	XS631028>631029>\$1
635034	CLRNDA 5 161.0	560001	NODAWAYCO 161.0	1	153	147.4	147.7	3.8%	S1399 to Humboldt	XS631019>631167>\$1
635034	CLRNDA 5 161.0	560001	NODAWAYCO 161.0	1	153	147.4	147.7	3.8%	S1399 to Humboldt	XS631025>629089>\$2
635034	CLRNDA 5 161.0	560001	NODAWAYCO 161.0	1	153	147.4	147.7	3.8%	S1399 to Humboldt	XS631062>630176>\$1
635034	CLRNDA 5 161.0	560001	NODAWAYCO 161.0	1	153	147.4	147.7	3.8%	S1399 to Humboldt	XS631019>629087>\$1
635034	CLRNDA 5 161.0	560001	NODAWAYCO 161.0	1	153	147.4	147.7	3.8%	S1399 to Humboldt	XS543066>543069>\$1
635034	CLRNDA 5 161.0	560001	NODAWAYCO 161.0	1	153	147.4	147.7	3.8%	S1399 to Humboldt	XS613420>681530>\$1
635034	CLRNDA 5 161.0	560001	NODAWAYCO 161.0	1	153	147.4	147.7	3.8%	S1399 to Humboldt	XS631022>631023>\$1
635034	CLRNDA 5 161.0	560001	NODAWAYCO 161.0	1	153	147.4	147.7	3.8%	S1399 to Humboldt	XS631085>636401>\$1
635034	CLRNDA 5 161.0	560001	NODAWAYCO 161.0	1	153	147.4	147.7	3.8%	S1399 to Humboldt	XS618900>631039>\$1
635034	CLRNDA 5 161.0	560001	NODAWAYCO 161.0	1	153	147.4	147.7	3.8%	S1399 to Humboldt	XS631054>629064>\$1
635034	CLRNDA 5 161.0	560001	NODAWAYCO 161.0	1	153	147.4	147.7	3.8%	S1399 to Humboldt	XS613330>681527>\$1
635034	CLRNDA 5 161.0	560001	NODAWAYCO 161.0	1	153	147.4	147.7	3.8%	S1399 to Humboldt	XS631018>631031>\$1

635034	CLRNDA 5 161.0	560001	NODAWAYCO 161.0	1	153	147.4	147.7	3.8%	S1399 to Humboldt	XS631018>631168>\$1
635034	CLRNDA 5 161.0	560001	NODAWAYCO 161.0	1	153	147.4	147.7	3.8%	S1399 to Humboldt	XS631060>630282>\$1
635034	CLRNDA 5 161.0	560001	NODAWAYCO 161.0	1	153	147.4	147.7	3.8%	S1399 to Humboldt	XS543063>543094>\$1
635034	CLRNDA 5 161.0	560001	NODAWAYCO 161.0	1	153	147.4	147.7	3.8%	S1399 to Humboldt	XS631091>629097>\$1
635034	CLRNDA 5 161.0	560001	NODAWAYCO 161.0	1	153	147.4	147.7	3.8%	S1399 to Humboldt	XS613370>613350>\$1
635034	CLRNDA 5 161.0	560001	NODAWAYCO 161.0	1	153	147.4	147.7	3.8%	S1399 to Humboldt	XS631054>629065>\$1
635034	CLRNDA 5 161.0	560001	NODAWAYCO 161.0	1	153	147.4	147.7	3.8%	S1399 to Humboldt	XS613370>613350>\$2
635034	CLRNDA 5 161.0	560001	NODAWAYCO 161.0	1	153	147.4	147.7	3.8%	S1399 to Humboldt	XS631027>631146>\$1
635034	CLRNDA 5 161.0	560001	NODAWAYCO 161.0	1	153	147.4	147.7	3.8%	S1399 to Humboldt	XS631018>631089>\$1
635034	CLRNDA 5 161.0	560001	NODAWAYCO 161.0	1	153	147.4	147.7	3.8%	S1399 to Humboldt	XS631052>681523>\$1
635034	CLRNDA 5 161.0	560001	NODAWAYCO 161.0	1	153	147.4	147.7	3.8%	S1399 to Humboldt	XS631051>630256>\$1
635034	CLRNDA 5 161.0	560001	NODAWAYCO 161.0	1	153	147.4	147.7	3.8%	S1399 to Humboldt	XS543069>543112>\$1
635034	CLRNDA 5 161.0	560001	NODAWAYCO 161.0	1	153	147.4	147.7	3.8%	S1399 to Humboldt	XS631090>630026>\$1
635034	CLRNDA 5 161.0	560001	NODAWAYCO 161.0	1	153	147.4	147.7	3.8%	S1399 to Humboldt	XS631031>631167>\$1
635034	CLRNDA 5 161.0	560001	NODAWAYCO 161.0	1	153	147.4	147.7	3.8%	S1399 to Humboldt	XS631059>630290>\$1
635034	CLRNDA 5 161.0	560001	NODAWAYCO 161.0	1	153	147.4	147.7	3.8%	S1399 to Humboldt	XS631038>630056>\$1
635034	CLRNDA 5 161.0	560001	NODAWAYCO 161.0	1	153	147.4	147.7	3.8%	S1399 to Humboldt	XS631019>629087>\$2
635034	CLRNDA 5 161.0	560001	NODAWAYCO 161.0	1	153	147.4	147.7	3.8%	S1399 to Humboldt	XS631019>631027>\$1
635034	CLRNDA 5 161.0	560001	NODAWAYCO 161.0	1	153	147.4	147.7	3.8%	S1399 to Humboldt	XS618900>631040>\$1
635034	CLRNDA 5 161.0	560001	NODAWAYCO 161.0	1	153	147.4	147.7	3.8%	S1399 to Humboldt	XS631089>631147>\$1
635034	CLRNDA 5 161.0	560001	NODAWAYCO 161.0	1	153	147.4	147.7	3.8%	S1399 to Humboldt	XS631025>629089>\$1
635034	CLRNDA 5 161.0	560001	NODAWAYCO 161.0	1	153	147.4	147.7	3.8%	S1399 to Humboldt	XS631056>630280>\$1
635034	CLRNDA 5 161.0	560001	NODAWAYCO 161.0	1	153	147.4	147.7	3.8%	S1399 to Humboldt	XS631056>630281>\$1
635034	CLRNDA 5 161.0	560001	NODAWAYCO 161.0	1	153	147.5	147.7	3.8%	S975 (Humboldt) T4 161-69	XS300039>541199>\$1
635034	CLRNDA 5 161.0	560001	NODAWAYCO 161.0	1	153	147.5	147.7	3.8%	S975 (Humboldt) T4 161-69	XS532768>532796>\$1
635034	CLRNDA 5 161.0	560001	NODAWAYCO 161.0	1	153	147.4	147.7	3.8%	S975 (Humboldt) T4 161-69	XS646258>646263>\$1
635034	CLRNDA 5 161.0	560001	NODAWAYCO 161.0	1	153	147.2	147.6	5.7%	S1399 to Humboldt	XS533338>560141>\$1

635034	CLRNDA 5	161.0	560001	NODAWAYCO	161.0	1	153	147.3	147.6	4.8%	S1399 to Humboldt	XS631123>681527>\$1
635034	CLRNDA 5	161.0	560001	NODAWAYCO	161.0	1	153	147.3	147.6	4.8%	S1399 to Humboldt	XS635607>635710>\$1
635034	CLRNDA 5	161.0	560001	NODAWAYCO	161.0	1	153	147.3	147.6	4.8%	S1399 to Humboldt	XS631121>635681>\$1
635034	CLRNDA 5	161.0	560001	NODAWAYCO	161.0	1	153	147.3	147.6	4.8%	S1399 to Humboldt	XS631121>631129>\$1
635034	CLRNDA 5	161.0	560001	NODAWAYCO	161.0	1	153	147.3	147.6	4.8%	S1399 to Humboldt	XS631110>630048>\$2
635034	CLRNDA 5	161.0	560001	NODAWAYCO	161.0	1	153	147.3	147.6	4.8%	S1399 to Humboldt	XS631110>630048>\$1
635034	CLRNDA 5	161.0	560001	NODAWAYCO	161.0	1	153	147.3	147.6	4.8%	S1399 to Humboldt	XS635600>635700>\$1
635034	CLRNDA 5	161.0	560001	NODAWAYCO	161.0	1	153	147.3	147.6	4.8%	S1399 to Humboldt	XS631109>347840>\$1
635034	CLRNDA 5	161.0	560001	NODAWAYCO	161.0	1	153	147.3	147.6	4.8%	S1399 to Humboldt	XS635201>635225>\$1
635034	CLRNDA 5	161.0	560001	NODAWAYCO	161.0	1	153	147.3	147.6	4.8%	S1399 to Humboldt	XS635600>635700>\$2
635034	CLRNDA 5	161.0	560001	NODAWAYCO	161.0	1	153	147.3	147.6	4.8%	S1399 to Humboldt	XS635630>635635>\$1
635034	CLRNDA 5	161.0	560001	NODAWAYCO	161.0	1	153	147.2	147.6	4.8%	S1399 to Humboldt	XS635610>635654>\$1
635034	CLRNDA 5	161.0	560001	NODAWAYCO	161.0	1	153	147.3	147.6	4.8%	S1399 to Humboldt	XS635610>635612>\$1
635034	CLRNDA 5	161.0	560001	NODAWAYCO	161.0	1	153	147.3	147.6	4.8%	S1399 to Humboldt	XS631144>601002>\$1
635034	CLRNDA 5	161.0	560001	NODAWAYCO	161.0	1	153	147.3	147.6	4.8%	S1399 to Humboldt	XS631129>630718>\$1
635034	CLRNDA 5	161.0	560001	NODAWAYCO	161.0	1	153	147.3	147.6	4.8%	S1399 to Humboldt	XS635612>635613>\$1
635034	CLRNDA 5	161.0	560001	NODAWAYCO	161.0	1	153	147.3	147.6	4.8%	S1399 to Humboldt	XS635613>635631>\$1
635034	CLRNDA 5	161.0	560001	NODAWAYCO	161.0	1	153	147.3	147.6	4.8%	S1399 to Humboldt	XS636200>656087>\$1
635034	CLRNDA 5	161.0	560001	NODAWAYCO	161.0	1	153	147.3	147.6	4.8%	S1399 to Humboldt	XS635223>635225>\$1
635034	CLRNDA 5	161.0	560001	NODAWAYCO	161.0	1	153	147.3	147.6	4.8%	S1399 to Humboldt	XS635340>635350>\$1
635034	CLRNDA 5	161.0	560001	NODAWAYCO	161.0	1	153	147.3	147.6	4.8%	S1399 to Humboldt	XS636025>636030>\$1
635034	CLRNDA 5	161.0	560001	NODAWAYCO	161.0	1	153	147.3	147.6	4.8%	S1399 to Humboldt	XS631100>631101>\$1
635034	CLRNDA 5	161.0	560001	NODAWAYCO	161.0	1	153	147.3	147.6	4.8%	S1399 to Humboldt	XS636030>636031>636032\$1
635034	CLRNDA 5	161.0	560001	NODAWAYCO	161.0	1	153	147.3	147.6	4.8%	S1399 to Humboldt	XS640100>640101>\$1
635034	CLRNDA 5	161.0	560001	NODAWAYCO	161.0	1	153	147.3	147.6	4.8%	S1399 to Humboldt	XS636300>656087>\$1
635034	CLRNDA 5	161.0	560001	NODAWAYCO	161.0	1	153	147.3	147.6	4.8%	S1399 to Humboldt	XS636672>348915>\$2
635034	CLRNDA 5	161.0	560001	NODAWAYCO	161.0	1	153	147.3	147.6	4.8%	S1399 to Humboldt	XS640167>659130>\$1

635034	CLRNDA 5 161.0	560001	NODAWAYCO 161.0	1	153	147.3	147.6	4.8%	S1399 to Humboldt	XS636240>636241>\$1
635034	CLRNDA 5 161.0	560001	NODAWAYCO 161.0	1	153	147.3	147.6	4.8%	S1399 to Humboldt	XS636660>636661>\$1
635034	CLRNDA 5 161.0	560001	NODAWAYCO 161.0	1	153	147.3	147.6	4.8%	S1399 to Humboldt	XS636615>636620>\$1
635034	CLRNDA 5 161.0	560001	NODAWAYCO 161.0	1	153	147.3	147.6	4.8%	S1399 to Humboldt	XS636675>636677>\$1
635034	CLRNDA 5 161.0	560001	NODAWAYCO 161.0	1	153	147.3	147.6	4.8%	S1399 to Humboldt	XS640051>640367>\$1
635034	CLRNDA 5 161.0	560001	NODAWAYCO 161.0	1	153	147.3	147.6	4.8%	S1399 to Humboldt	XS640147>640148>\$1
635034	CLRNDA 5 161.0	560001	NODAWAYCO 161.0	1	153	147.3	147.6	4.8%	S1399 to Humboldt	XS640111>640112>\$1
635034	CLRNDA 5 161.0	560001	NODAWAYCO 161.0	1	153	147.3	147.6	4.8%	S1399 to Humboldt	XS636675>636676>\$1
635034	CLRNDA 5 161.0	560001	NODAWAYCO 161.0	1	153	147.3	147.6	4.8%	S1399 to Humboldt	XS640063>640064>\$1
635034	CLRNDA 5 161.0	560001	NODAWAYCO 161.0	1	153	147.3	147.6	4.8%	S1399 to Humboldt	XS640091>640092>\$1
635034	CLRNDA 5 161.0	560001	NODAWAYCO 161.0	1	153	147.3	147.6	4.8%	S1399 to Humboldt	XS640065>640312>\$1
635034	CLRNDA 5 161.0	560001	NODAWAYCO 161.0	1	153	147.3	147.6	4.8%	S1399 to Humboldt	XS640115>640293>\$1
635034	CLRNDA 5 161.0	560001	NODAWAYCO 161.0	1	153	147.3	147.6	4.8%	S1399 to Humboldt	XS640165>640305>\$1
635034	CLRNDA 5 161.0	560001	NODAWAYCO 161.0	1	153	147.3	147.6	4.8%	S1399 to Humboldt	XS640117>640394>\$1
635034	CLRNDA 5 161.0	560001	NODAWAYCO 161.0	1	153	147.3	147.6	4.8%	S1399 to Humboldt	XS640054>640347>\$1
635034	CLRNDA 5 161.0	560001	NODAWAYCO 161.0	1	153	147.3	147.6	4.8%	S1399 to Humboldt	XS636401>636678>\$1
635034	CLRNDA 5 161.0	560001	NODAWAYCO 161.0	1	153	147.3	147.6	4.8%	S1399 to Humboldt	XS640136>640345>\$1
635034	CLRNDA 5 161.0	560001	NODAWAYCO 161.0	1	153	147.3	147.6	4.8%	S1399 to Humboldt	XS640178>640180>\$1
635034	CLRNDA 5 161.0	560001	NODAWAYCO 161.0	1	153	147.3	147.6	4.8%	S1399 to Humboldt	XS640070>640300>\$1
635034	CLRNDA 5 161.0	560001	NODAWAYCO 161.0	1	153	147.3	147.6	4.8%	S1399 to Humboldt	XS640173>640281>\$1
635034	CLRNDA 5 161.0	560001	NODAWAYCO 161.0	1	153	147.3	147.6	4.8%	S1399 to Humboldt	XS640086>640087>\$1
635034	CLRNDA 5 161.0	560001	NODAWAYCO 161.0	1	153	147.3	147.6	4.8%	S1399 to Humboldt	XS640072>640115>\$1
635034	CLRNDA 5 161.0	560001	NODAWAYCO 161.0	1	153	147.3	147.6	4.8%	S1399 to Humboldt	XS640381>640382>\$1
635034	CLRNDA 5 161.0	560001	NODAWAYCO 161.0	1	153	147.3	147.6	4.8%	S1399 to Humboldt	XS640378>640379>\$1
635034	CLRNDA 5 161.0	560001	NODAWAYCO 161.0	1	153	147.2	147.6	4.8%	S1399 to Humboldt	XS640222>640223>\$1
635034	CLRNDA 5 161.0	560001	NODAWAYCO 161.0	1	153	147.3	147.6	4.8%	S1399 to Humboldt	XS640386>652565>\$1
635034	CLRNDA 5 161.0	560001	NODAWAYCO 161.0	1	153	147.3	147.6	4.8%	S1399 to Humboldt	XS645001>645102>\$1

635034	CLRND 5	161.0	560001	NODAWAYCO	161.0	1	153	147.3	147.6	4.8%	S1399 to Humboldt	XS640318>640319>\$1
635034	CLRND 5	161.0	560001	NODAWAYCO	161.0	1	153	147.3	147.6	4.8%	S1399 to Humboldt	XS640370>640371>\$1
635034	CLRND 5	161.0	560001	NODAWAYCO	161.0	1	153	147.3	147.6	4.8%	S1399 to Humboldt	XS640368>640369>\$1
635034	CLRND 5	161.0	560001	NODAWAYCO	161.0	1	153	147.3	147.6	4.8%	S1399 to Humboldt	XS640316>640340>\$1
635034	CLRND 5	161.0	560001	NODAWAYCO	161.0	1	153	147.3	147.6	4.8%	S1399 to Humboldt	XS640316>650214>\$1
635034	CLRND 5	161.0	560001	NODAWAYCO	161.0	1	153	147.3	147.6	4.8%	S1399 to Humboldt	XS640277>640278>640280\$1
635034	CLRND 5	161.0	560001	NODAWAYCO	161.0	1	153	147.3	147.6	4.8%	S1399 to Humboldt	XS640402>648402>\$1
635034	CLRND 5	161.0	560001	NODAWAYCO	161.0	1	153	147.3	147.6	4.8%	S1399 to Humboldt	XS640411>640443>\$1
635034	CLRND 5	161.0	560001	NODAWAYCO	161.0	1	153	147.3	147.6	4.8%	S1399 to Humboldt	XS640271>652571>\$1
635034	CLRND 5	161.0	560001	NODAWAYCO	161.0	1	153	147.3	147.6	4.8%	S1399 to Humboldt	XS641082>641091>\$1
635034	CLRND 5	161.0	560001	NODAWAYCO	161.0	1	153	147.3	147.6	4.8%	S1399 to Humboldt	XS640263>640264>\$1
635034	CLRND 5	161.0	560001	NODAWAYCO	161.0	1	153	147.3	147.6	4.8%	S1399 to Humboldt	XS640426>640427>\$1
635034	CLRND 5	161.0	560001	NODAWAYCO	161.0	1	153	147.3	147.6	4.8%	S1399 to Humboldt	XS640287>640365>\$1
635034	CLRND 5	161.0	560001	NODAWAYCO	161.0	1	153	147.3	147.6	4.8%	S1399 to Humboldt	XS640387>640389>\$1
635034	CLRND 5	161.0	560001	NODAWAYCO	161.0	1	153	147.3	147.6	4.8%	S1399 to Humboldt	XS640278>640279>\$1
635034	CLRND 5	161.0	560001	NODAWAYCO	161.0	1	153	147.2	147.6	4.8%	S1399 to Humboldt	XS640252>659133>\$1
635034	CLRND 5	161.0	560001	NODAWAYCO	161.0	1	153	147.3	147.6	4.8%	S1399 to Humboldt	XS640392>640394>\$1
635034	CLRND 5	161.0	560001	NODAWAYCO	161.0	1	153	147.3	147.6	4.8%	S1399 to Humboldt	XS640281>648401>\$1
635034	CLRND 5	161.0	560001	NODAWAYCO	161.0	1	153	147.3	147.6	4.8%	S1399 to Humboldt	XS640281>648400>\$1
635034	CLRND 5	161.0	560001	NODAWAYCO	161.0	1	153	147.3	147.6	4.8%	S1399 to Humboldt	XS640194>640242>\$1
635034	CLRND 5	161.0	560001	NODAWAYCO	161.0	1	153	147.3	147.6	4.8%	S1399 to Humboldt	XS645128>646211>\$1
635034	CLRND 5	161.0	560001	NODAWAYCO	161.0	1	153	147.3	147.6	4.8%	S1399 to Humboldt	XS645127>646211>\$1
635034	CLRND 5	161.0	560001	NODAWAYCO	161.0	1	153	147.3	147.6	4.8%	S1399 to Humboldt	XS640363>640364>\$1
635034	CLRND 5	161.0	560001	NODAWAYCO	161.0	1	153	147.3	147.6	4.8%	S1399 to Humboldt	XS645126>647911>\$1
635034	CLRND 5	161.0	560001	NODAWAYCO	161.0	1	153	147.3	147.6	4.8%	S1399 to Humboldt	XS645100>645103>\$1
635034	CLRND 5	161.0	560001	NODAWAYCO	161.0	1	153	147.3	147.6	4.8%	S1399 to Humboldt	XS640334>640335>643130\$1
635034	CLRND 5	161.0	560001	NODAWAYCO	161.0	1	153	147.3	147.6	4.8%	S1399 to Humboldt	XS640183>640252>\$1

635034	CLRND 5	161.0	560001	NODAWAYCO	161.0	1	153	147.3	147.6	4.8%	S1399 to Humboldt	XS640328>640329>\$1
635034	CLRND 5	161.0	560001	NODAWAYCO	161.0	1	153	147.3	147.6	4.8%	S1399 to Humboldt	XS640357>640358>\$1
635034	CLRND 5	161.0	560001	NODAWAYCO	161.0	1	153	147.3	147.6	4.8%	S1399 to Humboldt	XS647907>647911>\$1
635034	CLRND 5	161.0	560001	NODAWAYCO	161.0	1	153	147.3	147.6	4.8%	S1399 to Humboldt	XS647907>647919>\$1
635034	CLRND 5	161.0	560001	NODAWAYCO	161.0	1	153	147.3	147.6	4.8%	S1399 to Humboldt	XS650267>650284>\$1
635034	CLRND 5	161.0	560001	NODAWAYCO	161.0	1	153	147.3	147.6	4.8%	S1399 to Humboldt	XS647909>647937>\$1
635034	CLRND 5	161.0	560001	NODAWAYCO	161.0	1	153	147.3	147.6	4.8%	S1399 to Humboldt	XS646209>646250>\$2
635034	CLRND 5	161.0	560001	NODAWAYCO	161.0	1	153	147.3	147.6	4.8%	S1399 to Humboldt	XS646209>646250>\$1
635034	CLRND 5	161.0	560001	NODAWAYCO	161.0	1	153	147.3	147.6	4.8%	S1399 to Humboldt	XS647006>647079>\$1
635034	CLRND 5	161.0	560001	NODAWAYCO	161.0	1	153	147.3	147.6	4.8%	S1399 to Humboldt	XS646206>647906>648206\$1
635034	CLRND 5	161.0	560001	NODAWAYCO	161.0	1	153	147.2	147.6	4.8%	S1399 to Humboldt	XS647904>647985>\$1
635034	CLRND 5	161.0	560001	NODAWAYCO	161.0	1	153	147.3	147.6	4.8%	S1399 to Humboldt	XS650275>650284>\$1
635034	CLRND 5	161.0	560001	NODAWAYCO	161.0	1	153	147.3	147.6	4.8%	S1399 to Humboldt	XS646201>646220>\$1
635034	CLRND 5	161.0	560001	NODAWAYCO	161.0	1	153	147.3	147.6	4.8%	S1399 to Humboldt	XS647900>647972>\$1
635034	CLRND 5	161.0	560001	NODAWAYCO	161.0	1	153	147.3	147.6	4.8%	S1399 to Humboldt	XS647874>647995>\$1
635034	CLRND 5	161.0	560001	NODAWAYCO	161.0	1	153	147.3	147.6	4.8%	S1399 to Humboldt	XS646206>646232>\$1
635034	CLRND 5	161.0	560001	NODAWAYCO	161.0	1	153	147.3	147.6	4.8%	S1399 to Humboldt	XS646201>646286>\$1
635034	CLRND 5	161.0	560001	NODAWAYCO	161.0	1	153	147.3	147.6	4.8%	S1399 to Humboldt	XS647902>647937>\$1
635034	CLRND 5	161.0	560001	NODAWAYCO	161.0	1	153	147.3	147.6	4.8%	S1399 to Humboldt	XS647902>647984>\$1
635034	CLRND 5	161.0	560001	NODAWAYCO	161.0	1	153	147.3	147.6	4.8%	S1399 to Humboldt	XS647014>647988>\$1
635034	CLRND 5	161.0	560001	NODAWAYCO	161.0	1	153	147.3	147.6	4.8%	S1399 to Humboldt	XS646211>646250>\$1
635034	CLRND 5	161.0	560001	NODAWAYCO	161.0	1	153	147.3	147.6	4.8%	S1399 to Humboldt	XS650242>650342>650542\$1
635034	CLRND 5	161.0	560001	NODAWAYCO	161.0	1	153	147.3	147.6	4.8%	S1399 to Humboldt	XS646211>646250>\$2
635034	CLRND 5	161.0	560001	NODAWAYCO	161.0	1	153	147.3	147.6	4.8%	S1399 to Humboldt	XS647963>647973>\$1
635034	CLRND 5	161.0	560001	NODAWAYCO	161.0	1	153	147.3	147.6	4.8%	S1399 to Humboldt	XS647965>647975>\$1
635034	CLRND 5	161.0	560001	NODAWAYCO	161.0	1	153	147.3	147.6	4.8%	S1399 to Humboldt	XS647079>647900>\$1
635034	CLRND 5	161.0	560001	NODAWAYCO	161.0	1	153	147.2	147.6	4.8%	S1399 to Humboldt	XS647091>647991>\$1

635034	CLRND 5	161.0	560001	NODAWAYCO	161.0	1	153	147.3	147.6	4.8%	S1399 to Humboldt	XS647090>647990>\$1
635034	CLRND 5	161.0	560001	NODAWAYCO	161.0	1	153	147.3	147.6	4.8%	S1399 to Humboldt	XS646209>646252>\$1
635034	CLRND 5	161.0	560001	NODAWAYCO	161.0	1	153	147.3	147.6	4.8%	S1399 to Humboldt	XS650261>650269>\$1
635034	CLRND 5	161.0	560001	NODAWAYCO	161.0	1	153	147.3	147.6	4.8%	S1399 to Humboldt	XS647985>640320>\$1
635034	CLRND 5	161.0	560001	NODAWAYCO	161.0	1	153	147.3	147.6	4.8%	S1399 to Humboldt	XS646210>646222>\$1
635034	CLRND 5	161.0	560001	NODAWAYCO	161.0	1	153	147.3	147.6	4.8%	S1399 to Humboldt	XS646211>646220>\$1
635034	CLRND 5	161.0	560001	NODAWAYCO	161.0	1	153	147.3	147.6	4.8%	S1399 to Humboldt	XS646259>646281>\$1
635034	CLRND 5	161.0	560001	NODAWAYCO	161.0	1	153	147.3	147.6	4.8%	S1399 to Humboldt	XS647424>647976>\$1
635034	CLRND 5	161.0	560001	NODAWAYCO	161.0	1	153	147.3	147.6	4.8%	S1399 to Humboldt	XS650215>650261>\$1
635034	CLRND 5	161.0	560001	NODAWAYCO	161.0	1	153	147.3	147.6	4.8%	S1399 to Humboldt	XS652312>659241>\$1
635034	CLRND 5	161.0	560001	NODAWAYCO	161.0	1	153	147.3	147.6	4.8%	S1399 to Humboldt	XS652300>652301>\$1
635034	CLRND 5	161.0	560001	NODAWAYCO	161.0	1	153	147.3	147.6	4.8%	S1399 to Humboldt	XS300057>300555>\$1
635034	CLRND 5	161.0	560001	NODAWAYCO	161.0	1	153	147.3	147.6	4.8%	S1399 to Humboldt	XS300088>301077>\$1
635034	CLRND 5	161.0	560001	NODAWAYCO	161.0	1	153	147.3	147.6	4.8%	S1399 to Humboldt	XS300075>505434>\$1
635034	CLRND 5	161.0	560001	NODAWAYCO	161.0	1	153	147.3	147.6	4.8%	S1399 to Humboldt	XS300061>343014>\$1
635034	CLRND 5	161.0	560001	NODAWAYCO	161.0	1	153	147.3	147.6	4.8%	S1399 to Humboldt	XS300095>301161>\$1
635034	CLRND 5	161.0	560001	NODAWAYCO	161.0	1	153	147.3	147.6	4.8%	S1399 to Humboldt	XS300088>300109>\$1
635034	CLRND 5	161.0	560001	NODAWAYCO	161.0	1	153	147.3	147.6	4.8%	S1399 to Humboldt	XS300063>344233>\$1
635034	CLRND 5	161.0	560001	NODAWAYCO	161.0	1	153	147.3	147.6	4.8%	S1399 to Humboldt	XS300056>505434>\$1
635034	CLRND 5	161.0	560001	NODAWAYCO	161.0	1	153	147.3	147.6	4.8%	S1399 to Humboldt	XS300076>301347>\$1
635034	CLRND 5	161.0	560001	NODAWAYCO	161.0	1	153	147.3	147.6	4.8%	S1399 to Humboldt	XS300064>300065>\$1
635034	CLRND 5	161.0	560001	NODAWAYCO	161.0	1	153	147.3	147.6	4.8%	S1399 to Humboldt	XS300063>300550>\$1
635034	CLRND 5	161.0	560001	NODAWAYCO	161.0	1	153	147.3	147.6	4.8%	S1399 to Humboldt	XS300056>505438>\$1
635034	CLRND 5	161.0	560001	NODAWAYCO	161.0	1	153	147.2	147.6	4.8%	S1399 to Humboldt	XS300088>300102>\$1
635034	CLRND 5	161.0	560001	NODAWAYCO	161.0	1	153	147.3	147.6	4.8%	S1399 to Humboldt	XS300087>300226>\$1
635034	CLRND 5	161.0	560001	NODAWAYCO	161.0	1	153	147.3	147.6	4.8%	S1399 to Humboldt	XS300040>300047>\$1
635034	CLRND 5	161.0	560001	NODAWAYCO	161.0	1	153	147.3	147.6	4.8%	S1399 to Humboldt	XS300093>301211>\$1

635034	CLRND 5	161.0	560001	NODAWAYCO	161.0	1	153	147.3	147.6	4.8%	S1399 to Humboldt	XS300092>301063>\$1
635034	CLRND 5	161.0	560001	NODAWAYCO	161.0	1	153	147.3	147.6	4.8%	S1399 to Humboldt	XS300058>300355>\$1
635034	CLRND 5	161.0	560001	NODAWAYCO	161.0	1	153	147.3	147.6	4.8%	S1399 to Humboldt	S973NOBKR
635034	CLRND 5	161.0	560001	NODAWAYCO	161.0	1	153	147.3	147.6	4.8%	S1399 to Humboldt	S976-FRE-D-E
635034	CLRND 5	161.0	560001	NODAWAYCO	161.0	1	153	147.3	147.6	4.8%	S1399 to Humboldt	XS300071>505502>\$1
635034	CLRND 5	161.0	560001	NODAWAYCO	161.0	1	153	147.3	147.6	4.8%	S1399 to Humboldt	MC1235-31-34
635034	CLRND 5	161.0	560001	NODAWAYCO	161.0	1	153	147.2	147.6	4.8%	S1399 to Humboldt	S991TAP
635034	CLRND 5	161.0	560001	NODAWAYCO	161.0	1	153	147.3	147.6	4.8%	S1399 to Humboldt	XS300041>300078>\$2
635034	CLRND 5	161.0	560001	NODAWAYCO	161.0	1	153	147.3	147.6	4.8%	S1399 to Humboldt	XS300047>300112>\$1
635034	CLRND 5	161.0	560001	NODAWAYCO	161.0	1	153	147.3	147.6	4.8%	S1399 to Humboldt	XS300081>505460>\$1
635034	CLRND 5	161.0	560001	NODAWAYCO	161.0	1	153	147.3	147.6	4.8%	S1399 to Humboldt	XS300041>300078>\$1
635034	CLRND 5	161.0	560001	NODAWAYCO	161.0	1	153	147.3	147.6	4.8%	S1399 to Humboldt	XS300078>300092>\$1
635034	CLRND 5	161.0	560001	NODAWAYCO	161.0	1	153	147.3	147.6	4.8%	S1399 to Humboldt	MC995-38-94
635034	CLRND 5	161.0	560001	NODAWAYCO	161.0	1	153	147.3	147.6	4.8%	S1399 to Humboldt	XS300080>301076>\$1
635034	CLRND 5	161.0	560001	NODAWAYCO	161.0	1	153	147.3	147.6	4.8%	S1399 to Humboldt	XS300045>549984>\$1
635034	CLRND 5	161.0	560001	NODAWAYCO	161.0	1	153	147.3	147.6	4.8%	S1399 to Humboldt	XS300102>301159>\$1
635034	CLRND 5	161.0	560001	NODAWAYCO	161.0	1	153	147.3	147.6	4.8%	S1399 to Humboldt	MC1209-1231
635034	CLRND 5	161.0	560001	NODAWAYCO	161.0	1	153	147.3	147.6	4.8%	S1399 to Humboldt	XS300064>301077>\$1
635034	CLRND 5	161.0	560001	NODAWAYCO	161.0	1	153	147.3	147.6	4.8%	S1399 to Humboldt	XS300084>301211>\$1
635034	CLRND 5	161.0	560001	NODAWAYCO	161.0	1	153	147.3	147.6	4.8%	S1399 to Humboldt	S1206T1 BSCL
635034	CLRND 5	161.0	560001	NODAWAYCO	161.0	1	153	147.3	147.6	4.8%	S1399 to Humboldt	XS300038>344974>\$1
635034	CLRND 5	161.0	560001	NODAWAYCO	161.0	1	153	147.3	147.6	4.8%	S1399 to Humboldt	XS300054>300168>\$1
635034	CLRND 5	161.0	560001	NODAWAYCO	161.0	1	153	147.3	147.6	4.8%	S1399 to Humboldt	XS300084>505440>\$1
635034	CLRND 5	161.0	560001	NODAWAYCO	161.0	1	153	147.3	147.6	4.8%	S1399 to Humboldt	S1206T2 BSCL
635034	CLRND 5	161.0	560001	NODAWAYCO	161.0	1	153	147.3	147.6	4.8%	S1399 to Humboldt	XS300084>300115>\$1
635034	CLRND 5	161.0	560001	NODAWAYCO	161.0	1	153	147.3	147.6	4.8%	S1399 to Humboldt	XS300077>345798>\$1
635034	CLRND 5	161.0	560001	NODAWAYCO	161.0	1	153	147.3	147.6	4.8%	S1399 to Humboldt	XS300126>345221>\$1

635034	CLRNDA 5 161.0	560001	NODAWAYCO 161.0	1	153	147.3	147.6	4.8%	S1399 to Humboldt	XS300129>300763>\$1
635034	CLRNDA 5 161.0	560001	NODAWAYCO 161.0	1	153	147.3	147.6	4.8%	S1399 to Humboldt	XS300595>345498>\$1
635034	CLRNDA 5 161.0	560001	NODAWAYCO 161.0	1	153	147.3	147.6	4.8%	S1399 to Humboldt	XS300136>514906>\$1
635034	CLRNDA 5 161.0	560001	NODAWAYCO 161.0	1	153	147.3	147.6	4.8%	S1399 to Humboldt	XS300118>505498>\$1
635034	CLRNDA 5 161.0	560001	NODAWAYCO 161.0	1	153	147.3	147.6	4.8%	S1399 to Humboldt	XS300113>345437>\$1
635034	CLRNDA 5 161.0	560001	NODAWAYCO 161.0	1	153	147.3	147.6	4.8%	S1399 to Humboldt	XS532912>546742>\$1
635034	CLRNDA 5 161.0	560001	NODAWAYCO 161.0	1	153	147.3	147.6	4.8%	S1399 to Humboldt	XS532912>533238>532940\$1
635034	CLRNDA 5 161.0	560001	NODAWAYCO 161.0	1	153	147.3	147.6	4.8%	S1399 to Humboldt	XS300617>300637>\$1
635034	CLRNDA 5 161.0	560001	NODAWAYCO 161.0	1	153	147.3	147.6	4.8%	S1399 to Humboldt	XS300122>300858>\$1
635034	CLRNDA 5 161.0	560001	NODAWAYCO 161.0	1	153	147.3	147.6	4.8%	S1399 to Humboldt	XS532851>532852>\$1
635034	CLRNDA 5 161.0	560001	NODAWAYCO 161.0	1	153	147.3	147.6	4.8%	S1399 to Humboldt	XS532865>533347>532901\$1
635034	CLRNDA 5 161.0	560001	NODAWAYCO 161.0	1	153	147.3	147.6	4.8%	S1399 to Humboldt	XS300138>300141>\$1
635034	CLRNDA 5 161.0	560001	NODAWAYCO 161.0	1	153	147.3	147.6	4.8%	S1399 to Humboldt	XS300168>301124>\$1
635034	CLRNDA 5 161.0	560001	NODAWAYCO 161.0	1	153	147.3	147.6	4.8%	S1399 to Humboldt	XS532794>514803>\$1
635034	CLRNDA 5 161.0	560001	NODAWAYCO 161.0	1	153	147.3	147.6	4.8%	S1399 to Humboldt	XS300917>301128>\$1
635034	CLRNDA 5 161.0	560001	NODAWAYCO 161.0	1	153	147.3	147.6	4.8%	S1399 to Humboldt	XS532932>547476>\$1
635034	CLRNDA 5 161.0	560001	NODAWAYCO 161.0	1	153	147.3	147.6	4.8%	S1399 to Humboldt	XS300134>300599>\$1
635034	CLRNDA 5 161.0	560001	NODAWAYCO 161.0	1	153	147.3	147.6	4.8%	S1399 to Humboldt	XS532853>533250>532882\$1
635034	CLRNDA 5 161.0	560001	NODAWAYCO 161.0	1	153	147.3	147.6	4.8%	S1399 to Humboldt	XS301144>344360>\$1
635034	CLRNDA 5 161.0	560001	NODAWAYCO 161.0	1	153	147.3	147.6	4.8%	S1399 to Humboldt	XS300858>345798>\$1
635034	CLRNDA 5 161.0	560001	NODAWAYCO 161.0	1	153	147.3	147.6	4.8%	S1399 to Humboldt	XS300109>301071>\$1
635034	CLRNDA 5 161.0	560001	NODAWAYCO 161.0	1	153	147.3	147.6	4.8%	S1399 to Humboldt	XS300599>344880>\$1
635034	CLRNDA 5 161.0	560001	NODAWAYCO 161.0	1	153	147.3	147.6	4.8%	S1399 to Humboldt	XS300867>505522>\$1
635034	CLRNDA 5 161.0	560001	NODAWAYCO 161.0	1	153	147.3	147.6	4.8%	S1399 to Humboldt	XS533153>533456>533443\$1
635034	CLRNDA 5 161.0	560001	NODAWAYCO 161.0	1	153	147.3	147.6	4.8%	S1399 to Humboldt	XS533371>533381>\$1
635034	CLRNDA 5 161.0	560001	NODAWAYCO 161.0	1	153	147.3	147.6	4.8%	S1399 to Humboldt	XS533261>533282>\$1
635034	CLRNDA 5 161.0	560001	NODAWAYCO 161.0	1	153	147.3	147.6	4.8%	S1399 to Humboldt	XS533267>543042>532948\$1

635034	CLRND 5	161.0	560001	NODAWAYCO	161.0	1	153	147.3	147.6	4.8%	S1399 to Humboldt	XS533235>533240>\$1
635034	CLRND 5	161.0	560001	NODAWAYCO	161.0	1	153	147.3	147.6	4.8%	S1399 to Humboldt	XS533235>533283>\$1
635034	CLRND 5	161.0	560001	NODAWAYCO	161.0	1	153	147.3	147.6	4.8%	S1399 to Humboldt	XS533345>533347>\$1
635034	CLRND 5	161.0	560001	NODAWAYCO	161.0	1	153	147.3	147.6	4.8%	S1399 to Humboldt	XS533002>533004>\$1
635034	CLRND 5	161.0	560001	NODAWAYCO	161.0	1	153	147.3	147.6	4.8%	S1399 to Humboldt	XS533252>533261>\$1
635034	CLRND 5	161.0	560001	NODAWAYCO	161.0	1	153	147.3	147.6	4.8%	S1399 to Humboldt	XS533322>533337>\$1
635034	CLRND 5	161.0	560001	NODAWAYCO	161.0	1	153	147.2	147.6	4.8%	S1399 to Humboldt	XS533322>533338>\$1
635034	CLRND 5	161.0	560001	NODAWAYCO	161.0	1	153	147.3	147.6	4.8%	S1399 to Humboldt	XS532981>514804>\$1
635034	CLRND 5	161.0	560001	NODAWAYCO	161.0	1	153	147.3	147.6	4.8%	S1399 to Humboldt	XS659162>659163>\$1
635034	CLRND 5	161.0	560001	NODAWAYCO	161.0	1	153	147.2	147.6	4.8%	S1399 to Humboldt	XS652508>652552>\$1
635034	CLRND 5	161.0	560001	NODAWAYCO	161.0	1	153	147.3	147.6	4.8%	S1399 to Humboldt	XS652519>652488>\$1
635034	CLRND 5	161.0	560001	NODAWAYCO	161.0	1	153	147.3	147.6	4.8%	S1399 to Humboldt	XS652550>652582>\$1
635034	CLRND 5	161.0	560001	NODAWAYCO	161.0	1	153	147.3	147.6	4.8%	S1399 to Humboldt	XS652535>652291>\$1
635034	CLRND 5	161.0	560001	NODAWAYCO	161.0	1	153	147.3	147.6	4.8%	S1399 to Humboldt	XS659132>659246>\$1
635034	CLRND 5	161.0	560001	NODAWAYCO	161.0	1	153	147.3	147.6	4.8%	S1399 to Humboldt	XS652533>652289>\$1
635034	CLRND 5	161.0	560001	NODAWAYCO	161.0	1	153	147.3	147.6	4.8%	S1399 to Humboldt	XS652524>652235>\$1
635034	CLRND 5	161.0	560001	NODAWAYCO	161.0	1	153	147.3	147.6	4.8%	S1399 to Humboldt	XS652530>652582>\$1
635034	CLRND 5	161.0	560001	NODAWAYCO	161.0	1	153	147.3	147.6	4.8%	S1399 to Humboldt	XS659133>659135>\$1
635034	CLRND 5	161.0	560001	NODAWAYCO	161.0	1	153	147.3	147.6	4.8%	S1399 to Humboldt	XS659246>659247>\$1
635034	CLRND 5	161.0	560001	NODAWAYCO	161.0	1	153	147.3	147.6	4.8%	S1399 to Humboldt	XS652550>602009>\$1
635034	CLRND 5	161.0	560001	NODAWAYCO	161.0	1	153	147.3	147.6	4.8%	S1399 to Humboldt	XS652503>652530>\$1
635034	CLRND 5	161.0	560001	NODAWAYCO	161.0	1	153	147.3	147.6	4.8%	S1399 to Humboldt	CB971-BUS990
635034	CLRND 5	161.0	560001	NODAWAYCO	161.0	1	153	147.3	147.6	4.8%	S1399 to Humboldt	CB1201-20&T1
635034	CLRND 5	161.0	560001	NODAWAYCO	161.0	1	153	147.3	147.6	4.8%	S1399 to Humboldt	CB968TEC7469
635034	CLRND 5	161.0	560001	NODAWAYCO	161.0	1	153	147.3	147.6	4.8%	S1399 to Humboldt	CB910-BUS
635034	CLRND 5	161.0	560001	NODAWAYCO	161.0	1	153	147.3	147.6	4.8%	S1399 to Humboldt	CB1206-32&01
635034	CLRND 5	161.0	560001	NODAWAYCO	161.0	1	153	147.3	147.6	4.8%	S1399 to Humboldt	CB1206-01&T2

635034	CLRND 5	161.0	560001	NODAWAYCO	161.0	1	153	147.2	147.6	4.8%	S1399 to Humboldt	CB982-BUS990
635034	CLRND 5	161.0	560001	NODAWAYCO	161.0	1	153	147.3	147.6	4.8%	S1399 to Humboldt	CB1305-BUS
635034	CLRND 5	161.0	560001	NODAWAYCO	161.0	1	153	147.3	147.6	4.8%	S1399 to Humboldt	LES0010A
635034	CLRND 5	161.0	560001	NODAWAYCO	161.0	1	153	147.3	147.6	4.8%	S1399 to Humboldt	CB923-12-PXM
635034	CLRND 5	161.0	560001	NODAWAYCO	161.0	1	153	147.3	147.6	4.8%	S1399 to Humboldt	CB1235-36&53
635034	CLRND 5	161.0	560001	NODAWAYCO	161.0	1	153	147.3	147.6	4.8%	S1399 to Humboldt	CB1250-09&T1
635034	CLRND 5	161.0	560001	NODAWAYCO	161.0	1	153	147.3	147.6	4.8%	S1399 to Humboldt	CB1231-09&35
635034	CLRND 5	161.0	560001	NODAWAYCO	161.0	1	153	147.3	147.6	4.8%	S1399 to Humboldt	CB906N69B916
635034	CLRND 5	161.0	560001	NODAWAYCO	161.0	1	153	147.3	147.6	4.8%	S1399 to Humboldt	LES1404
635034	CLRND 5	161.0	560001	NODAWAYCO	161.0	1	153	147.2	147.6	4.8%	S1399 to Humboldt	CB6846-BUS
635034	CLRND 5	161.0	560001	NODAWAYCO	161.0	1	153	147.3	147.6	4.8%	S1399 to Humboldt	CB995-BUS
635034	CLRND 5	161.0	560001	NODAWAYCO	161.0	1	153	147.3	147.6	4.8%	S1399 to Humboldt	LES1402A
635034	CLRND 5	161.0	560001	NODAWAYCO	161.0	1	153	147.3	147.6	4.8%	S1399 to Humboldt	LN-1181
635034	CLRND 5	161.0	560001	NODAWAYCO	161.0	1	153	147.2	147.6	4.8%	S1399 to Humboldt	AUBNOBKR
635034	CLRND 5	161.0	560001	NODAWAYCO	161.0	1	153	147.3	147.6	4.8%	S1399 to Humboldt	LN-FRIEND
635034	CLRND 5	161.0	560001	NODAWAYCO	161.0	1	153	147.3	147.6	4.8%	S1399 to Humboldt	CB983-BUS
635034	CLRND 5	161.0	560001	NODAWAYCO	161.0	1	153	147.3	147.6	4.8%	S1399 to Humboldt	BKR-GRI-1396
635034	CLRND 5	161.0	560001	NODAWAYCO	161.0	1	153	147.3	147.6	4.8%	S1399 to Humboldt	LN-1176
635034	CLRND 5	161.0	560001	NODAWAYCO	161.0	1	153	147.3	147.6	4.8%	S1399 to Humboldt	XS542969>543126>\$1
635034	CLRND 5	161.0	560001	NODAWAYCO	161.0	1	153	147.3	147.6	4.8%	S1399 to Humboldt	XS541205>541237>\$1
635034	CLRND 5	161.0	560001	NODAWAYCO	161.0	1	153	147.3	147.6	4.8%	S1399 to Humboldt	XS542985>543021>\$1
635034	CLRND 5	161.0	560001	NODAWAYCO	161.0	1	153	147.2	147.6	4.8%	S1399 to Humboldt	XS542969>543050>\$1
635034	CLRND 5	161.0	560001	NODAWAYCO	161.0	1	153	147.3	147.6	4.8%	S1399 to Humboldt	XS533419>533440>\$1
635034	CLRND 5	161.0	560001	NODAWAYCO	161.0	1	153	147.3	147.6	4.8%	S1399 to Humboldt	XS542969>543053>\$1
635034	CLRND 5	161.0	560001	NODAWAYCO	161.0	1	153	147.3	147.6	4.8%	S1399 to Humboldt	XS541219>541238>\$1
635034	CLRND 5	161.0	560001	NODAWAYCO	161.0	1	153	147.3	147.6	4.8%	S1399 to Humboldt	XS541200>541201>\$1
635034	CLRND 5	161.0	560001	NODAWAYCO	161.0	1	153	147.3	147.6	4.8%	S1399 to Humboldt	XS541237>541238>\$1

635034	CLRND 5	161.0	560001	NODAWAYCO	161.0	1	153	147.2	147.6	4.8%	S1399 to Humboldt	XS542969>542994>\$1
635034	CLRND 5	161.0	560001	NODAWAYCO	161.0	1	153	147.3	147.6	4.8%	S1399 to Humboldt	XS542972>542973>543644\$20
635034	CLRND 5	161.0	560001	NODAWAYCO	161.0	1	153	147.3	147.6	4.8%	S1399 to Humboldt	XS543031>543039>\$1
635034	CLRND 5	161.0	560001	NODAWAYCO	161.0	1	153	147.3	147.6	4.8%	S1399 to Humboldt	XS541242>300071>\$1
635034	CLRND 5	161.0	560001	NODAWAYCO	161.0	1	153	147.3	147.6	4.8%	S1399 to Humboldt	XS543031>543041>\$1
635034	CLRND 5	161.0	560001	NODAWAYCO	161.0	1	153	147.3	147.6	4.8%	S1399 to Humboldt	XS541218>541313>\$1
635034	CLRND 5	161.0	560001	NODAWAYCO	161.0	1	153	147.3	147.6	4.8%	S1399 to Humboldt	XS541259>541340>\$1
635034	CLRND 5	161.0	560001	NODAWAYCO	161.0	1	153	147.3	147.6	4.8%	S1399 to Humboldt	XS541340>541342>\$1
635034	CLRND 5	161.0	560001	NODAWAYCO	161.0	1	153	147.3	147.6	4.8%	S1399 to Humboldt	XS542993>542994>\$1
635034	CLRND 5	161.0	560001	NODAWAYCO	161.0	1	153	147.3	147.6	4.8%	S1399 to Humboldt	XS542966>543044>\$1
635034	CLRND 5	161.0	560001	NODAWAYCO	161.0	1	153	147.3	147.6	4.8%	S1399 to Humboldt	XS542977>542978>543641\$11
635034	CLRND 5	161.0	560001	NODAWAYCO	161.0	1	153	147.3	147.6	4.8%	S1399 to Humboldt	XS543017>546669>\$1
635034	CLRND 5	161.0	560001	NODAWAYCO	161.0	1	153	147.3	147.6	4.8%	S1399 to Humboldt	XS542995>541317>\$1
635034	CLRND 5	161.0	560001	NODAWAYCO	161.0	1	153	147.3	147.6	4.8%	S1399 to Humboldt	XS541209>541241>\$1
635034	CLRND 5	161.0	560001	NODAWAYCO	161.0	1	153	147.3	147.6	4.8%	S1399 to Humboldt	XS542968>542969>543647\$11
635034	CLRND 5	161.0	560001	NODAWAYCO	161.0	1	153	147.3	147.6	4.8%	S1399 to Humboldt	XS542968>542969>543648\$22
635034	CLRND 5	161.0	560001	NODAWAYCO	161.0	1	153	147.2	147.6	4.8%	S1399 to Humboldt	XS543015>543027>\$1
635034	CLRND 5	161.0	560001	NODAWAYCO	161.0	1	153	147.3	147.6	4.8%	S1399 to Humboldt	XS543002>541210>\$1
635034	CLRND 5	161.0	560001	NODAWAYCO	161.0	1	153	147.3	147.6	4.8%	S1399 to Humboldt	XS542991>546651>\$1
635034	CLRND 5	161.0	560001	NODAWAYCO	161.0	1	153	147.3	147.6	4.8%	S1399 to Humboldt	XS533440>533455>\$1
635034	CLRND 5	161.0	560001	NODAWAYCO	161.0	1	153	147.3	147.6	4.8%	S1399 to Humboldt	XS543042>543126>\$1
635034	CLRND 5	161.0	560001	NODAWAYCO	161.0	1	153	147.3	147.6	4.8%	S1399 to Humboldt	XS541203>541204>\$1
635034	CLRND 5	161.0	560001	NODAWAYCO	161.0	1	153	147.3	147.6	4.8%	S1399 to Humboldt	XS542978>542979>\$1
635034	CLRND 5	161.0	560001	NODAWAYCO	161.0	1	153	147.3	147.6	4.8%	S1399 to Humboldt	XS541225>541313>\$1
635034	CLRND 5	161.0	560001	NODAWAYCO	161.0	1	153	147.3	147.6	4.8%	S1399 to Humboldt	XS541224>541249>\$1
635034	CLRND 5	161.0	560001	NODAWAYCO	161.0	1	153	147.3	147.6	4.8%	S1399 to Humboldt	XS543038>543052>\$1
635034	CLRND 5	161.0	560001	NODAWAYCO	161.0	1	153	147.3	147.6	4.8%	S1399 to Humboldt	XS542978>543039>\$1

635034	CLRND 5	161.0	560001	NODAWAYCO	161.0	1	153	147.3	147.6	4.8%	S1399 to Humboldt	XS543036>543046>\$1
635034	CLRND 5	161.0	560001	NODAWAYCO	161.0	1	153	147.3	147.6	4.8%	S1399 to Humboldt	XS541222>541224>\$1
635034	CLRND 5	161.0	560001	NODAWAYCO	161.0	1	153	147.2	147.6	4.8%	S1399 to Humboldt	XS541202>541250>\$1
635034	CLRND 5	161.0	560001	NODAWAYCO	161.0	1	153	147.3	147.6	4.8%	S1399 to Humboldt	XS543036>543045>\$1
635034	CLRND 5	161.0	560001	NODAWAYCO	161.0	1	153	147.3	147.6	4.8%	S1399 to Humboldt	XS543046>543050>\$1
635034	CLRND 5	161.0	560001	NODAWAYCO	161.0	1	153	147.3	147.6	4.8%	S1399 to Humboldt	XS542977>542978>543642\$22
635034	CLRND 5	161.0	560001	NODAWAYCO	161.0	1	153	147.3	147.6	4.8%	S1399 to Humboldt	XS542979>543047>\$1
635034	CLRND 5	161.0	560001	NODAWAYCO	161.0	1	153	147.2	147.6	4.8%	S1399 to Humboldt	XS541201>541202>541360\$1
635034	CLRND 5	161.0	560001	NODAWAYCO	161.0	1	153	147.3	147.6	4.8%	S1399 to Humboldt	XS543045>543051>\$1
635034	CLRND 5	161.0	560001	NODAWAYCO	161.0	1	153	147.3	147.6	4.8%	S1399 to Humboldt	XS631033>631067>\$1
635034	CLRND 5	161.0	560001	NODAWAYCO	161.0	1	153	147.3	147.6	4.8%	S1399 to Humboldt	XS631005>631175>\$1
635034	CLRND 5	161.0	560001	NODAWAYCO	161.0	1	153	147.3	147.6	4.8%	S1399 to Humboldt	XS631048>636300>\$1
635034	CLRND 5	161.0	560001	NODAWAYCO	161.0	1	153	147.2	147.6	4.8%	S1399 to Humboldt	XS631003>631030>\$1
635034	CLRND 5	161.0	560001	NODAWAYCO	161.0	1	153	147.3	147.6	4.8%	S1399 to Humboldt	XS631051>631101>\$1
635034	CLRND 5	161.0	560001	NODAWAYCO	161.0	1	153	147.3	147.6	4.8%	S1399 to Humboldt	XS631002>631005>\$1
635034	CLRND 5	161.0	560001	NODAWAYCO	161.0	1	153	147.3	147.6	4.8%	S1399 to Humboldt	XS631033>271543>\$1
635034	CLRND 5	161.0	560001	NODAWAYCO	161.0	1	153	147.3	147.6	4.8%	S1399 to Humboldt	XS631087>629103>\$1
635034	CLRND 5	161.0	560001	NODAWAYCO	161.0	1	153	147.3	147.6	4.8%	S1399 to Humboldt	XS631004>631013>\$1
635034	CLRND 5	161.0	560001	NODAWAYCO	161.0	1	153	147.3	147.6	4.8%	S1399 to Humboldt	XS631041>631042>\$1
635034	CLRND 5	161.0	560001	NODAWAYCO	161.0	1	153	147.3	147.6	4.8%	S1399 to Humboldt	XS631036>631047>\$1
635034	CLRND 5	161.0	560001	NODAWAYCO	161.0	1	153	147.3	147.6	4.8%	S1399 to Humboldt	XS631080>631182>\$1
635034	CLRND 5	161.0	560001	NODAWAYCO	161.0	1	153	147.3	147.6	4.8%	S1399 to Humboldt	XS631036>631174>\$1
635034	CLRND 5	161.0	560001	NODAWAYCO	161.0	1	153	147.3	147.6	4.8%	S1399 to Humboldt	XS631085>631113>\$1
635034	CLRND 5	161.0	560001	NODAWAYCO	161.0	1	153	147.3	147.6	4.8%	S1399 to Humboldt	XS543064>300105>\$1
635034	CLRND 5	161.0	560001	NODAWAYCO	161.0	1	153	147.3	147.6	4.8%	S1399 to Humboldt	XS631064>631067>\$1
635034	CLRND 5	161.0	560001	NODAWAYCO	161.0	1	153	147.3	147.6	4.8%	S1399 to Humboldt	XS631047>631048>\$2
635034	CLRND 5	161.0	560001	NODAWAYCO	161.0	1	153	147.3	147.6	4.8%	S1399 to Humboldt	XS631047>631048>\$1

635034	CLRNDA 5	161.0	560001	NODAWAYCO	161.0	1	153	147.3	147.6	4.8%	S1399 to Humboldt	XS560553>560554>\$1
635034	CLRNDA 5	161.0	560001	NODAWAYCO	161.0	1	153	147.3	147.6	4.8%	S1399 to Humboldt	XS631073>631092>\$1
635034	CLRNDA 5	161.0	560001	NODAWAYCO	161.0	1	153	147.3	147.6	4.8%	S1399 to Humboldt	XS631045>631127>\$1
635034	CLRNDA 5	161.0	560001	NODAWAYCO	161.0	1	153	147.3	147.6	4.8%	S1399 to Humboldt	XS631073>631099>\$1
635034	CLRNDA 5	161.0	560001	NODAWAYCO	161.0	1	153	147.3	147.6	4.8%	S1399 to Humboldt	XS631083>631086>\$1
635034	CLRNDA 5	161.0	560001	NODAWAYCO	161.0	1	153	147.3	147.6	4.8%	S1399 to Humboldt	XS631094>629098>\$1
635034	CLRNDA 5	161.0	560001	NODAWAYCO	161.0	1	153	147.3	147.6	4.8%	S1399 to Humboldt	XS631056>631060>\$1
635034	CLRNDA 5	161.0	560001	NODAWAYCO	161.0	1	153	147.3	147.6	4.8%	S1399 to Humboldt	XS631023>629093>\$1
635034	CLRNDA 5	161.0	560001	NODAWAYCO	161.0	1	153	147.3	147.6	4.8%	S1399 to Humboldt	XS543060>543061>\$1
635034	CLRNDA 5	161.0	560001	NODAWAYCO	161.0	1	153	147.3	147.6	4.8%	S1399 to Humboldt	XS631084>631108>\$1
635034	CLRNDA 5	161.0	560001	NODAWAYCO	161.0	1	153	147.3	147.6	4.8%	S1399 to Humboldt	XS560553>560554>\$2
635034	CLRNDA 5	161.0	560001	NODAWAYCO	161.0	1	153	147.3	147.6	4.8%	S1399 to Humboldt	XS543059>543064>\$1
635034	CLRNDA 5	161.0	560001	NODAWAYCO	161.0	1	153	147.3	147.6	4.8%	S1399 to Humboldt	XS631007>631074>\$2
635034	CLRNDA 5	161.0	560001	NODAWAYCO	161.0	1	153	147.3	147.6	4.8%	S1399 to Humboldt	XS631001>631012>\$1
635034	CLRNDA 5	161.0	560001	NODAWAYCO	161.0	1	153	147.4	147.6	3.8%	S1280 to Humboldt	XS631134>635870>\$1
635034	CLRNDA 5	161.0	560001	NODAWAYCO	161.0	1	153	147.3	147.6	3.8%	S1280 to Humboldt	CB1206-T2&T4
635034	CLRNDA 5	161.0	560001	NODAWAYCO	161.0	1	153	147.3	147.6	3.8%	S1399 to Humboldt	XS635039>635040>\$1
635034	CLRNDA 5	161.0	560001	NODAWAYCO	161.0	1	153	147.3	147.6	3.8%	S1399 to Humboldt	XS636001>656353>\$1
635034	CLRNDA 5	161.0	560001	NODAWAYCO	161.0	1	153	147.3	147.6	3.8%	S1399 to Humboldt	XS635610>635662>\$1
635034	CLRNDA 5	161.0	560001	NODAWAYCO	161.0	1	153	147.3	147.6	3.8%	S1399 to Humboldt	XS640058>640165>\$1
635034	CLRNDA 5	161.0	560001	NODAWAYCO	161.0	1	153	147.3	147.6	3.8%	S1399 to Humboldt	XS640155>640156>\$1
635034	CLRNDA 5	161.0	560001	NODAWAYCO	161.0	1	153	147.3	147.6	3.8%	S1399 to Humboldt	XS640058>640367>\$1
635034	CLRNDA 5	161.0	560001	NODAWAYCO	161.0	1	153	147.3	147.6	3.8%	S1399 to Humboldt	XS640133>640343>\$1
635034	CLRNDA 5	161.0	560001	NODAWAYCO	161.0	1	153	147.3	147.6	3.8%	S1399 to Humboldt	XS640174>640175>\$1
635034	CLRNDA 5	161.0	560001	NODAWAYCO	161.0	1	153	147.3	147.6	3.8%	S1399 to Humboldt	XS640235>640236>\$1
635034	CLRNDA 5	161.0	560001	NODAWAYCO	161.0	1	153	147.3	147.6	3.8%	S1399 to Humboldt	XS640300>640400>\$1
635034	CLRNDA 5	161.0	560001	NODAWAYCO	161.0	1	153	147.3	147.6	3.8%	S1399 to Humboldt	XS640342>640343>643136\$1

635034	CLRND 5	161.0	560001	NODAWAYCO	161.0	1	153	147.3	147.6	3.8%	S1399 to Humboldt	XS640349>640350>\$1
635034	CLRND 5	161.0	560001	NODAWAYCO	161.0	1	153	147.3	147.6	3.8%	S1399 to Humboldt	XS645021>645121>\$1
635034	CLRND 5	161.0	560001	NODAWAYCO	161.0	1	153	147.3	147.6	3.8%	S1399 to Humboldt	XS646231>646235>\$1
635034	CLRND 5	161.0	560001	NODAWAYCO	161.0	1	153	147.3	147.6	3.8%	S1399 to Humboldt	XS646211>647911>648211\$1
635034	CLRND 5	161.0	560001	NODAWAYCO	161.0	1	153	147.3	147.6	3.8%	S1399 to Humboldt	XS647919>647930>\$1
635034	CLRND 5	161.0	560001	NODAWAYCO	161.0	1	153	147.3	147.6	3.8%	S1399 to Humboldt	XS646211>646299>\$1
635034	CLRND 5	161.0	560001	NODAWAYCO	161.0	1	153	147.3	147.6	3.8%	S1399 to Humboldt	XS650261>650361>650561\$1
635034	CLRND 5	161.0	560001	NODAWAYCO	161.0	1	153	147.3	147.6	3.8%	S1399 to Humboldt	XS646286>646299>\$1
635034	CLRND 5	161.0	560001	NODAWAYCO	161.0	1	153	147.3	147.6	3.8%	S1399 to Humboldt	XS650226>650326>650526\$1
635034	CLRND 5	161.0	560001	NODAWAYCO	161.0	1	153	147.3	147.6	3.8%	S1399 to Humboldt	XS647106>647923>\$1
635034	CLRND 5	161.0	560001	NODAWAYCO	161.0	1	153	147.3	147.6	3.8%	S1399 to Humboldt	XS647400>647968>\$1
635034	CLRND 5	161.0	560001	NODAWAYCO	161.0	1	153	147.3	147.6	3.8%	S1399 to Humboldt	XS300078>300080>\$1
635034	CLRND 5	161.0	560001	NODAWAYCO	161.0	1	153	147.3	147.6	3.8%	S1399 to Humboldt	XS300082>300105>\$1
635034	CLRND 5	161.0	560001	NODAWAYCO	161.0	1	153	147.3	147.6	3.8%	S1399 to Humboldt	MC930-18-19
635034	CLRND 5	161.0	560001	NODAWAYCO	161.0	1	153	147.3	147.6	3.8%	S1399 to Humboldt	S968LINBUS
635034	CLRND 5	161.0	560001	NODAWAYCO	161.0	1	153	147.3	147.6	3.8%	S1399 to Humboldt	S982-90-71
635034	CLRND 5	161.0	560001	NODAWAYCO	161.0	1	153	147.3	147.6	3.8%	S1399 to Humboldt	XS300617>344028>\$1
635034	CLRND 5	161.0	560001	NODAWAYCO	161.0	1	153	147.3	147.6	3.8%	S1399 to Humboldt	XS300590>300595>\$1
635034	CLRND 5	161.0	560001	NODAWAYCO	161.0	1	153	147.3	147.6	3.8%	S1399 to Humboldt	XS300122>300917>\$1
635034	CLRND 5	161.0	560001	NODAWAYCO	161.0	1	153	147.3	147.6	3.8%	S1399 to Humboldt	XS301063>301076>\$1
635034	CLRND 5	161.0	560001	NODAWAYCO	161.0	1	153	147.3	147.6	3.8%	S1399 to Humboldt	XS300597>344535>\$1
635034	CLRND 5	161.0	560001	NODAWAYCO	161.0	1	153	147.3	147.6	3.8%	S1399 to Humboldt	XS300590>300606>\$1
635034	CLRND 5	161.0	560001	NODAWAYCO	161.0	1	153	147.3	147.6	3.8%	S1399 to Humboldt	XS532853>532855>\$1
635034	CLRND 5	161.0	560001	NODAWAYCO	161.0	1	153	147.3	147.6	3.8%	S1399 to Humboldt	XS300867>505550>\$1
635034	CLRND 5	161.0	560001	NODAWAYCO	161.0	1	153	147.3	147.6	3.8%	S1399 to Humboldt	XS532855>533252>532884\$1
635034	CLRND 5	161.0	560001	NODAWAYCO	161.0	1	153	147.3	147.6	3.8%	S1399 to Humboldt	XS532794>532800>\$1
635034	CLRND 5	161.0	560001	NODAWAYCO	161.0	1	153	147.3	147.6	3.8%	S1399 to Humboldt	XS532934>532937>\$1

635034	CLRND 5 161.0	560001	NODAWAYCO 161.0	1	153	147.3	147.6	3.8%	S1399 to Humboldt	XS532872>533417>532894\$1
635034	CLRND 5 161.0	560001	NODAWAYCO 161.0	1	153	147.3	147.6	3.8%	S1399 to Humboldt	XS533240>533277>\$1
635034	CLRND 5 161.0	560001	NODAWAYCO 161.0	1	153	147.3	147.6	3.8%	S1399 to Humboldt	XS533238>533282>\$1
635034	CLRND 5 161.0	560001	NODAWAYCO 161.0	1	153	147.3	147.6	3.8%	S1399 to Humboldt	LES1403
635034	CLRND 5 161.0	560001	NODAWAYCO 161.0	1	153	147.3	147.6	3.8%	S1399 to Humboldt	CB968-67-TEC
635034	CLRND 5 161.0	560001	NODAWAYCO 161.0	1	153	147.3	147.6	3.8%	S1399 to Humboldt	CB1250-11&T1
635034	CLRND 5 161.0	560001	NODAWAYCO 161.0	1	153	147.3	147.6	3.8%	S1399 to Humboldt	CB1235-31&36
635034	CLRND 5 161.0	560001	NODAWAYCO 161.0	1	153	147.3	147.6	3.8%	S1399 to Humboldt	CB1209-50&31
635034	CLRND 5 161.0	560001	NODAWAYCO 161.0	1	153	147.3	147.6	3.8%	S1399 to Humboldt	CB1206-44&T1
635034	CLRND 5 161.0	560001	NODAWAYCO 161.0	1	153	147.3	147.6	3.8%	S1399 to Humboldt	CB1210-22&T7
635034	CLRND 5 161.0	560001	NODAWAYCO 161.0	1	153	147.3	147.6	3.8%	S1399 to Humboldt	XS543037>543043>\$1
635034	CLRND 5 161.0	560001	NODAWAYCO 161.0	1	153	147.3	147.6	3.8%	S1399 to Humboldt	XS542993>543001>\$1
635034	CLRND 5 161.0	560001	NODAWAYCO 161.0	1	153	147.3	147.6	3.8%	S1399 to Humboldt	XS541225>541243>\$1
635034	CLRND 5 161.0	560001	NODAWAYCO 161.0	1	153	147.3	147.6	3.8%	S1399 to Humboldt	XS542966>543049>\$1
635034	CLRND 5 161.0	560001	NODAWAYCO 161.0	1	153	147.3	147.6	3.8%	S1399 to Humboldt	XS542977>542978>543643\$33
635034	CLRND 5 161.0	560001	NODAWAYCO 161.0	1	153	147.3	147.6	3.8%	S1399 to Humboldt	XS543037>543044>\$1
635034	CLRND 5 161.0	560001	NODAWAYCO 161.0	1	153	147.3	147.6	3.8%	S1399 to Humboldt	XS543002>543053>\$1
635034	CLRND 5 161.0	560001	NODAWAYCO 161.0	1	153	147.3	147.6	3.8%	S1399 to Humboldt	XS542978>543038>\$1
635034	CLRND 5 161.0	560001	NODAWAYCO 161.0	1	153	147.3	147.6	3.8%	S1399 to Humboldt	XS542999>541317>\$1
635034	CLRND 5 161.0	560001	NODAWAYCO 161.0	1	153	147.3	147.6	3.8%	S1399 to Humboldt	XS541243>541249>\$1
635034	CLRND 5 161.0	560001	NODAWAYCO 161.0	1	153	147.3	147.6	3.8%	S1399 to Humboldt	XS543031>543049>\$1
635034	CLRND 5 161.0	560001	NODAWAYCO 161.0	1	153	147.3	147.6	3.8%	S1399 to Humboldt	XS631007>631074>\$1
635034	CLRND 5 161.0	560001	NODAWAYCO 161.0	1	153	147.3	147.6	3.8%	S1399 to Humboldt	XS543059>543063>\$1
635034	CLRND 5 161.0	560001	NODAWAYCO 161.0	1	153	147.3	147.6	3.8%	S1399 to Humboldt	XS631060>681519>\$1
635034	CLRND 5 161.0	560001	NODAWAYCO 161.0	1	153	147.4	147.6	3.8%	S975 (Humboldt) T4 161-69	XS640088>640024>\$1
635034	CLRND 5 161.0	560001	NODAWAYCO 161.0	1	153	147.4	147.6	3.8%	S975 (Humboldt) T4 161-69	XS641087>641086>\$1
635034	CLRND 5 161.0	560001	NODAWAYCO 161.0	1	153	147.4	147.6	3.8%	S975 (Humboldt) T4 161-69	XS532794>532797>\$1

635034	CLRNDA 5 161.0	560001	NODAWAYCO 161.0	1	153	147.4	147.6	3.8%	S975 (Humboldt) T4 161-69	XS646244>646258>\$1
635034	CLRNDA 5 161.0	560001	NODAWAYCO 161.0	1	153	147.4	147.6	3.8%	S975 (Humboldt) T4 161-69	XS543022>543029>\$1
635034	CLRNDA 5 161.0	560001	NODAWAYCO 161.0	1	153	147.4	147.6	3.8%	S975 (Humboldt) T4 161-69	CB1206-16&T4
635034	CLRNDA 5 161.0	560001	NODAWAYCO 161.0	1	153	147.3	147.6	3.8%	S1280 to Humboldt	XS300039>541199>\$1
635034	CLRNDA 5 161.0	560001	NODAWAYCO 161.0	1	153	147.3	147.6	3.8%	S1280 to Humboldt	XS541201>345408>\$1
635034	CLRNDA 5 161.0	560001	NODAWAYCO 161.0	1	153	147.2	147.6	3.8%	S1399 to Humboldt	XS640109>640110>\$1
635034	CLRNDA 5 161.0	560001	NODAWAYCO 161.0	1	153	147.2	147.6	3.8%	S1399 to Humboldt	XS636635>636636>\$1
635034	CLRNDA 5 161.0	560001	NODAWAYCO 161.0	1	153	147.2	147.6	3.8%	S1399 to Humboldt	XS640105>640415>\$1
635034	CLRNDA 5 161.0	560001	NODAWAYCO 161.0	1	153	147.2	147.6	3.8%	S1399 to Humboldt	XS645022>645122>\$1
635034	CLRNDA 5 161.0	560001	NODAWAYCO 161.0	1	153	147.2	147.6	3.8%	S1399 to Humboldt	XS645001>645101>\$1
635034	CLRNDA 5 161.0	560001	NODAWAYCO 161.0	1	153	147.2	147.6	3.8%	S1399 to Humboldt	XS640383>640385>\$1
635034	CLRNDA 5 161.0	560001	NODAWAYCO 161.0	1	153	147.2	147.6	3.8%	S1399 to Humboldt	XS640200>640330>\$1
635034	CLRNDA 5 161.0	560001	NODAWAYCO 161.0	1	153	147.3	147.6	3.8%	S1399 to Humboldt	XS640271>640277>\$1
635034	CLRNDA 5 161.0	560001	NODAWAYCO 161.0	1	153	147.2	147.6	3.8%	S1399 to Humboldt	XS646206>647006>648306\$1
635034	CLRNDA 5 161.0	560001	NODAWAYCO 161.0	1	153	147.2	147.6	3.8%	S1399 to Humboldt	XS645456>645459>\$1
635034	CLRNDA 5 161.0	560001	NODAWAYCO 161.0	1	153	147.2	147.6	3.8%	S1399 to Humboldt	XS300076>300249>\$2
635034	CLRNDA 5 161.0	560001	NODAWAYCO 161.0	1	153	147.2	147.6	3.8%	S1399 to Humboldt	XS300076>300249>\$1
635034	CLRNDA 5 161.0	560001	NODAWAYCO 161.0	1	153	147.2	147.6	3.8%	S1399 to Humboldt	XS300718>505472>\$1
635034	CLRNDA 5 161.0	560001	NODAWAYCO 161.0	1	153	147.2	147.6	3.8%	S1399 to Humboldt	XS533002>510422>\$1
635034	CLRNDA 5 161.0	560001	NODAWAYCO 161.0	1	153	147.2	147.6	3.8%	S1399 to Humboldt	XS659240>659300>\$1
635034	CLRNDA 5 161.0	560001	NODAWAYCO 161.0	1	153	147.2	147.6	3.8%	S1399 to Humboldt	XS659132>640303>\$1
635034	CLRNDA 5 161.0	560001	NODAWAYCO 161.0	1	153	147.2	147.6	3.8%	S1399 to Humboldt	LN-FIRTH
635034	CLRNDA 5 161.0	560001	NODAWAYCO 161.0	1	153	147.2	147.6	3.8%	S1399 to Humboldt	LN-1155
635034	CLRNDA 5 161.0	560001	NODAWAYCO 161.0	1	153	147.2	147.6	3.8%	S1399 to Humboldt	CB1214-BUS
635034	CLRNDA 5 161.0	560001	NODAWAYCO 161.0	1	153	147.2	147.6	3.8%	S1399 to Humboldt	XS541204>541221>\$1
635034	CLRNDA 5 161.0	560001	NODAWAYCO 161.0	1	153	147.3	147.6	3.8%	S1399 to Humboldt	XS541221>300307>\$1
635034	CLRNDA 5 161.0	560001	NODAWAYCO 161.0	1	153	147.2	147.6	3.8%	S1399 to Humboldt	XS541198>541200>\$1

635034	CLRND 5	161.0	560001	NODAWAYCO	161.0	1	153	147.2	147.6	3.8%	S1399 to Humboldt	XS542993>541210>\$1
635034	CLRND 5	161.0	560001	NODAWAYCO	161.0	1	153	147.2	147.6	3.8%	S1399 to Humboldt	XS631047>631154>\$1
635034	CLRND 5	161.0	560001	NODAWAYCO	161.0	1	153	147.2	147.6	3.8%	S1399 to Humboldt	XS631021>631022>\$1
635034	CLRND 5	161.0	560001	NODAWAYCO	161.0	1	153	147.2	147.6	3.8%	S1399 to Humboldt	XS631021>629096>\$1
635034	CLRND 5	161.0	560001	NODAWAYCO	161.0	1	153	147.3	147.6	3.8%	S975 (Humboldt) T4 161-69	TWR-ETR-RS
635034	CLRND 5	161.0	560001	NODAWAYCO	161.0	1	153	147.4	147.6	3.8%	S975 (Humboldt) T4 161-69	XS541257>541355>\$1
635034	CLRND 5	161.0	560001	NODAWAYCO	161.0	1	153	147.2	147.5	4.8%	S1399 to Humboldt	XS631123>631154>\$1
635034	CLRND 5	161.0	560001	NODAWAYCO	161.0	1	153	147.2	147.5	4.8%	S1399 to Humboldt	XS635200>652564>\$1
635034	CLRND 5	161.0	560001	NODAWAYCO	161.0	1	153	147.2	147.5	4.8%	S1399 to Humboldt	XS631110>631112>\$1
635034	CLRND 5	161.0	560001	NODAWAYCO	161.0	1	153	147.1	147.5	4.8%	S1399 to Humboldt	XS635651>635653>\$1
635034	CLRND 5	161.0	560001	NODAWAYCO	161.0	1	153	147.2	147.5	4.8%	S1399 to Humboldt	XS635631>635632>\$1
635034	CLRND 5	161.0	560001	NODAWAYCO	161.0	1	153	147.2	147.5	4.8%	S1399 to Humboldt	XS631138>601034>\$1
635034	CLRND 5	161.0	560001	NODAWAYCO	161.0	1	153	147.2	147.5	4.8%	S1399 to Humboldt	XS631099>629092>\$1
635034	CLRND 5	161.0	560001	NODAWAYCO	161.0	1	153	147.2	147.5	4.8%	S1399 to Humboldt	XS631106>631111>\$1
635034	CLRND 5	161.0	560001	NODAWAYCO	161.0	1	153	147.2	147.5	4.8%	S1399 to Humboldt	XS640070>640071>\$1
635034	CLRND 5	161.0	560001	NODAWAYCO	161.0	1	153	147.2	147.5	4.8%	S1399 to Humboldt	XS640054>640176>\$1
635034	CLRND 5	161.0	560001	NODAWAYCO	161.0	1	153	147.2	147.5	4.8%	S1399 to Humboldt	XS640051>640053>\$1
635034	CLRND 5	161.0	560001	NODAWAYCO	161.0	1	153	147.2	147.5	4.8%	S1399 to Humboldt	XS640161>640162>\$1
635034	CLRND 5	161.0	560001	NODAWAYCO	161.0	1	153	147.2	147.5	4.8%	S1399 to Humboldt	XS640157>640158>\$1
635034	CLRND 5	161.0	560001	NODAWAYCO	161.0	1	153	147.2	147.5	4.8%	S1399 to Humboldt	XS640159>640160>\$1
635034	CLRND 5	161.0	560001	NODAWAYCO	161.0	1	153	147.2	147.5	4.8%	S1399 to Humboldt	XS640062>647101>\$1
635034	CLRND 5	161.0	560001	NODAWAYCO	161.0	1	153	147.2	147.5	4.8%	S1399 to Humboldt	XS640176>640177>\$1
635034	CLRND 5	161.0	560001	NODAWAYCO	161.0	1	153	147.2	147.5	4.8%	S1399 to Humboldt	XS640078>640079>\$1
635034	CLRND 5	161.0	560001	NODAWAYCO	161.0	1	153	147.2	147.5	4.8%	S1399 to Humboldt	XS640084>640085>\$1
635034	CLRND 5	161.0	560001	NODAWAYCO	161.0	1	153	147.2	147.5	4.8%	S1399 to Humboldt	XS640144>640146>\$1
635034	CLRND 5	161.0	560001	NODAWAYCO	161.0	1	153	147.1	147.5	4.8%	S1399 to Humboldt	XS640377>640378>643151\$1
635034	CLRND 5	161.0	560001	NODAWAYCO	161.0	1	153	147.2	147.5	4.8%	S1399 to Humboldt	XS640383>640384>\$1

635034	CLRND 5	161.0	560001	NODAWAYCO	161.0	1	153	147.2	147.5	4.8%	S1399 to Humboldt	XS640300>640301>\$1
635034	CLRND 5	161.0	560001	NODAWAYCO	161.0	1	153	147.1	147.5	4.8%	S1399 to Humboldt	XS640300>640378>\$1
635034	CLRND 5	161.0	560001	NODAWAYCO	161.0	1	153	147.1	147.5	4.8%	S1399 to Humboldt	XS640321>640322>\$1
635034	CLRND 5	161.0	560001	NODAWAYCO	161.0	1	153	147.2	147.5	4.8%	S1399 to Humboldt	XS640220>640221>\$1
635034	CLRND 5	161.0	560001	NODAWAYCO	161.0	1	153	147.2	147.5	4.8%	S1399 to Humboldt	XS645023>645123>\$1
635034	CLRND 5	161.0	560001	NODAWAYCO	161.0	1	153	147.2	147.5	4.8%	S1399 to Humboldt	XS640316>640317>\$1
635034	CLRND 5	161.0	560001	NODAWAYCO	161.0	1	153	147.2	147.5	4.8%	S1399 to Humboldt	XS645024>645124>\$1
635034	CLRND 5	161.0	560001	NODAWAYCO	161.0	1	153	147.2	147.5	4.8%	S1399 to Humboldt	XS641083>641092>\$1
635034	CLRND 5	161.0	560001	NODAWAYCO	161.0	1	153	147.2	147.5	4.8%	S1399 to Humboldt	XS640277>640312>\$1
635034	CLRND 5	161.0	560001	NODAWAYCO	161.0	1	153	147.2	147.5	4.8%	S1399 to Humboldt	XS640259>640260>643095\$1
635034	CLRND 5	161.0	560001	NODAWAYCO	161.0	1	153	147.2	147.5	4.8%	S1399 to Humboldt	XS641083>641093>\$1
635034	CLRND 5	161.0	560001	NODAWAYCO	161.0	1	153	147.2	147.5	4.8%	S1399 to Humboldt	XS640256>640258>\$1
635034	CLRND 5	161.0	560001	NODAWAYCO	161.0	1	153	147.2	147.5	4.8%	S1399 to Humboldt	XS640272>640273>643171\$1
635034	CLRND 5	161.0	560001	NODAWAYCO	161.0	1	153	147.2	147.5	4.8%	S1399 to Humboldt	XS640409>640410>\$1
635034	CLRND 5	161.0	560001	NODAWAYCO	161.0	1	153	147.1	147.5	4.8%	S1399 to Humboldt	XS640402>640403>\$1
635034	CLRND 5	161.0	560001	NODAWAYCO	161.0	1	153	147.2	147.5	4.8%	S1399 to Humboldt	XS640392>640393>\$1
635034	CLRND 5	161.0	560001	NODAWAYCO	161.0	1	153	147.2	147.5	4.8%	S1399 to Humboldt	XS641090>641096>\$1
635034	CLRND 5	161.0	560001	NODAWAYCO	161.0	1	153	147.2	147.5	4.8%	S1399 to Humboldt	XS641085>641095>\$1
635034	CLRND 5	161.0	560001	NODAWAYCO	161.0	1	153	147.2	147.5	4.8%	S1399 to Humboldt	XS641084>641094>\$1
635034	CLRND 5	161.0	560001	NODAWAYCO	161.0	1	153	147.2	147.5	4.8%	S1399 to Humboldt	XS640201>640202>\$1
635034	CLRND 5	161.0	560001	NODAWAYCO	161.0	1	153	147.2	147.5	4.8%	S1399 to Humboldt	XS640196>640198>\$1
635034	CLRND 5	161.0	560001	NODAWAYCO	161.0	1	153	147.2	147.5	4.8%	S1399 to Humboldt	XS650169>646214>\$1
635034	CLRND 5	161.0	560001	NODAWAYCO	161.0	1	153	147.2	147.5	4.8%	S1399 to Humboldt	XS650169>650269>650369\$1
635034	CLRND 5	161.0	560001	NODAWAYCO	161.0	1	153	147.2	147.5	4.8%	S1399 to Humboldt	XS646201>646229>\$1
635034	CLRND 5	161.0	560001	NODAWAYCO	161.0	1	153	147.2	147.5	4.8%	S1399 to Humboldt	XS650228>650328>650528\$1
635034	CLRND 5	161.0	560001	NODAWAYCO	161.0	1	153	147.2	147.5	4.8%	S1399 to Humboldt	XS650273>650373>650573\$1
635034	CLRND 5	161.0	560001	NODAWAYCO	161.0	1	153	147.2	147.5	4.8%	S1399 to Humboldt	XS647904>647906>\$1

635034	CLRND 5	161.0	560001	NODAWAYCO	161.0	1	153	147.1	147.5	4.8%	S1399 to Humboldt	XS650272>650372>650572\$1
635034	CLRND 5	161.0	560001	NODAWAYCO	161.0	1	153	147.2	147.5	4.8%	S1399 to Humboldt	XS646206>646216>\$1
635034	CLRND 5	161.0	560001	NODAWAYCO	161.0	1	153	147.2	147.5	4.8%	S1399 to Humboldt	XS647107>647109>\$1
635034	CLRND 5	161.0	560001	NODAWAYCO	161.0	1	153	147.2	147.5	4.8%	S1399 to Humboldt	XS650274>650374>650574\$1
635034	CLRND 5	161.0	560001	NODAWAYCO	161.0	1	153	147.2	147.5	4.8%	S1399 to Humboldt	XS650250>650350>650550\$1
635034	CLRND 5	161.0	560001	NODAWAYCO	161.0	1	153	147.2	147.5	4.8%	S1399 to Humboldt	XS647079>647979>\$1
635034	CLRND 5	161.0	560001	NODAWAYCO	161.0	1	153	147.2	147.5	4.8%	S1399 to Humboldt	XS646216>646217>\$1
635034	CLRND 5	161.0	560001	NODAWAYCO	161.0	1	153	147.2	147.5	4.8%	S1399 to Humboldt	XS650262>650362>650562\$1
635034	CLRND 5	161.0	560001	NODAWAYCO	161.0	1	153	147.2	147.5	4.8%	S1399 to Humboldt	XS650262>650462>650662\$1
635034	CLRND 5	161.0	560001	NODAWAYCO	161.0	1	153	147.2	147.5	4.8%	S1399 to Humboldt	XS650240>650440>650640\$1
635034	CLRND 5	161.0	560001	NODAWAYCO	161.0	1	153	147.2	147.5	4.8%	S1399 to Humboldt	XS650240>650340>650540\$1
635034	CLRND 5	161.0	560001	NODAWAYCO	161.0	1	153	147.2	147.5	4.8%	S1399 to Humboldt	XS650208>650408>650608\$1
635034	CLRND 5	161.0	560001	NODAWAYCO	161.0	1	153	147.2	147.5	4.8%	S1399 to Humboldt	XS650284>650384>650584\$1
635034	CLRND 5	161.0	560001	NODAWAYCO	161.0	1	153	147.2	147.5	4.8%	S1399 to Humboldt	XS650212>650312>650512\$1
635034	CLRND 5	161.0	560001	NODAWAYCO	161.0	1	153	147.2	147.5	4.8%	S1399 to Humboldt	XS650208>650508>650708\$1
635034	CLRND 5	161.0	560001	NODAWAYCO	161.0	1	153	147.1	147.5	4.8%	S1399 to Humboldt	XS650216>650316>650516\$1
635034	CLRND 5	161.0	560001	NODAWAYCO	161.0	1	153	147.2	147.5	4.8%	S1399 to Humboldt	XS647112>647993>\$1
635034	CLRND 5	161.0	560001	NODAWAYCO	161.0	1	153	147.2	147.5	4.8%	S1399 to Humboldt	XS647426>647992>\$1
635034	CLRND 5	161.0	560001	NODAWAYCO	161.0	1	153	147.2	147.5	4.8%	S1399 to Humboldt	XS650283>650383>650583\$1
635034	CLRND 5	161.0	560001	NODAWAYCO	161.0	1	153	147.2	147.5	4.8%	S1399 to Humboldt	XS650283>650483>650683\$1
635034	CLRND 5	161.0	560001	NODAWAYCO	161.0	1	153	147.2	147.5	4.8%	S1399 to Humboldt	XS300030>300016>\$1
635034	CLRND 5	161.0	560001	NODAWAYCO	161.0	1	153	147.2	147.5	4.8%	S1399 to Humboldt	XS300030>300017>\$1
635034	CLRND 5	161.0	560001	NODAWAYCO	161.0	1	153	147.2	147.5	4.8%	S1399 to Humboldt	XS300030>300015>\$1
635034	CLRND 5	161.0	560001	NODAWAYCO	161.0	1	153	147.2	147.5	4.8%	S1399 to Humboldt	MC1216-917
635034	CLRND 5	161.0	560001	NODAWAYCO	161.0	1	153	147.2	147.5	4.8%	S1399 to Humboldt	XS300061>300519>\$1
635034	CLRND 5	161.0	560001	NODAWAYCO	161.0	1	153	147.2	147.5	4.8%	S1399 to Humboldt	XS300057>344532>\$1
635034	CLRND 5	161.0	560001	NODAWAYCO	161.0	1	153	147.1	147.5	4.8%	S1399 to Humboldt	XS300090>300519>\$1

635034	CLRNDA 5	161.0	560001	NODAWAYCO	161.0	1	153	147.2	147.5	4.8%	S1399 to Humboldt	S979TAP
635034	CLRNDA 5	161.0	560001	NODAWAYCO	161.0	1	153	147.2	147.5	4.8%	S1399 to Humboldt	XS300101>549969>\$1
635034	CLRNDA 5	161.0	560001	NODAWAYCO	161.0	1	153	147.2	147.5	4.8%	S1399 to Humboldt	XS300042>300088>\$1
635034	CLRNDA 5	161.0	560001	NODAWAYCO	161.0	1	153	147.2	147.5	4.8%	S1399 to Humboldt	MC1209-1250
635034	CLRNDA 5	161.0	560001	NODAWAYCO	161.0	1	153	147.2	147.5	4.8%	S1399 to Humboldt	XS300718>338120>\$1
635034	CLRNDA 5	161.0	560001	NODAWAYCO	161.0	1	153	147.2	147.5	4.8%	S1399 to Humboldt	XS532801>532727>\$1
635034	CLRNDA 5	161.0	560001	NODAWAYCO	161.0	1	153	147.2	147.5	4.8%	S1399 to Humboldt	XS300123>301107>\$1
635034	CLRNDA 5	161.0	560001	NODAWAYCO	161.0	1	153	147.2	147.5	4.8%	S1399 to Humboldt	XS300617>344815>\$1
635034	CLRNDA 5	161.0	560001	NODAWAYCO	161.0	1	153	147.2	147.5	4.8%	S1399 to Humboldt	XS532801>532728>\$1
635034	CLRNDA 5	161.0	560001	NODAWAYCO	161.0	1	153	147.2	147.5	4.8%	S1399 to Humboldt	XS301107>301124>\$1
635034	CLRNDA 5	161.0	560001	NODAWAYCO	161.0	1	153	147.2	147.5	4.8%	S1399 to Humboldt	XS533332>539665>\$1
635034	CLRNDA 5	161.0	560001	NODAWAYCO	161.0	1	153	147.1	147.5	4.8%	S1399 to Humboldt	XS652609>659198>\$1
635034	CLRNDA 5	161.0	560001	NODAWAYCO	161.0	1	153	147.2	147.5	4.8%	S1399 to Humboldt	XS652565>652562>\$1
635034	CLRNDA 5	161.0	560001	NODAWAYCO	161.0	1	153	147.2	147.5	4.8%	S1399 to Humboldt	XS652521>652285>\$1
635034	CLRNDA 5	161.0	560001	NODAWAYCO	161.0	1	153	147.2	147.5	4.8%	S1399 to Humboldt	XS652500>652271>\$1
635034	CLRNDA 5	161.0	560001	NODAWAYCO	161.0	1	153	147.2	147.5	4.8%	S1399 to Humboldt	XS652522>652209>\$1
635034	CLRNDA 5	161.0	560001	NODAWAYCO	161.0	1	153	147.2	147.5	4.8%	S1399 to Humboldt	XS652517>652230>\$1
635034	CLRNDA 5	161.0	560001	NODAWAYCO	161.0	1	153	147.2	147.5	4.8%	S1399 to Humboldt	XS652529>652530>652237\$1
635034	CLRNDA 5	161.0	560001	NODAWAYCO	161.0	1	153	147.1	147.5	4.8%	S1399 to Humboldt	XS652529>652537>\$1
635034	CLRNDA 5	161.0	560001	NODAWAYCO	161.0	1	153	147.2	147.5	4.8%	S1399 to Humboldt	CB909BUS&937
635034	CLRNDA 5	161.0	560001	NODAWAYCO	161.0	1	153	147.2	147.5	4.8%	S1399 to Humboldt	LES0008
635034	CLRNDA 5	161.0	560001	NODAWAYCO	161.0	1	153	147.2	147.5	4.8%	S1399 to Humboldt	CB972-BUS
635034	CLRNDA 5	161.0	560001	NODAWAYCO	161.0	1	153	147.2	147.5	4.8%	S1399 to Humboldt	LES7006
635034	CLRNDA 5	161.0	560001	NODAWAYCO	161.0	1	153	147.2	147.5	4.8%	S1399 to Humboldt	LES3005
635034	CLRNDA 5	161.0	560001	NODAWAYCO	161.0	1	153	147.2	147.5	4.8%	S1399 to Humboldt	LES3001
635034	CLRNDA 5	161.0	560001	NODAWAYCO	161.0	1	153	147.2	147.5	4.8%	S1399 to Humboldt	CB1206-32&T1
635034	CLRNDA 5	161.0	560001	NODAWAYCO	161.0	1	153	147.2	147.5	4.8%	S1399 to Humboldt	CB975-T4-993

635034	CLRND 5	161.0	560001	NODAWAYCO	161.0	1	153	147.2	147.5	4.8%	S1399 to Humboldt	CB976-BUS
635034	CLRND 5	161.0	560001	NODAWAYCO	161.0	1	153	147.1	147.5	4.8%	S1399 to Humboldt	CB906S-69A
635034	CLRND 5	161.0	560001	NODAWAYCO	161.0	1	153	147.2	147.5	4.8%	S1399 to Humboldt	LES0011
635034	CLRND 5	161.0	560001	NODAWAYCO	161.0	1	153	147.1	147.5	4.8%	S1399 to Humboldt	LES3302
635034	CLRND 5	161.0	560001	NODAWAYCO	161.0	1	153	147.2	147.5	4.8%	S1399 to Humboldt	D-CIRCUIT #6
635034	CLRND 5	161.0	560001	NODAWAYCO	161.0	1	153	147.2	147.5	4.8%	S1399 to Humboldt	CB906S-BT63
635034	CLRND 5	161.0	560001	NODAWAYCO	161.0	1	153	147.2	147.5	4.8%	S1399 to Humboldt	CB975-65-AUB
635034	CLRND 5	161.0	560001	NODAWAYCO	161.0	1	153	147.2	147.5	4.8%	S1399 to Humboldt	LES6701
635034	CLRND 5	161.0	560001	NODAWAYCO	161.0	1	153	147.2	147.5	4.8%	S1399 to Humboldt	LES6702
635034	CLRND 5	161.0	560001	NODAWAYCO	161.0	1	153	147.2	147.5	4.8%	S1399 to Humboldt	CB1250-11&97
635034	CLRND 5	161.0	560001	NODAWAYCO	161.0	1	153	147.2	147.5	4.8%	S1399 to Humboldt	CB1250-09&97
635034	CLRND 5	161.0	560001	NODAWAYCO	161.0	1	153	147.1	147.5	4.8%	S1399 to Humboldt	LES7003
635034	CLRND 5	161.0	560001	NODAWAYCO	161.0	1	153	147.1	147.5	4.8%	S1399 to Humboldt	CB1278-BUS
635034	CLRND 5	161.0	560001	NODAWAYCO	161.0	1	153	147.2	147.5	4.8%	S1399 to Humboldt	CB961-BUS&NH
635034	CLRND 5	161.0	560001	NODAWAYCO	161.0	1	153	147.2	147.5	4.8%	S1399 to Humboldt	LES6908
635034	CLRND 5	161.0	560001	NODAWAYCO	161.0	1	153	147.2	147.5	4.8%	S1399 to Humboldt	LES1405
635034	CLRND 5	161.0	560001	NODAWAYCO	161.0	1	153	147.2	147.5	4.8%	S1399 to Humboldt	LN-1160
635034	CLRND 5	161.0	560001	NODAWAYCO	161.0	1	153	147.1	147.5	4.8%	S1399 to Humboldt	LES0016
635034	CLRND 5	161.0	560001	NODAWAYCO	161.0	1	153	147.1	147.5	4.8%	S1399 to Humboldt	CBFREM-D
635034	CLRND 5	161.0	560001	NODAWAYCO	161.0	1	153	147.1	147.5	4.8%	S1399 to Humboldt	LN-1193
635034	CLRND 5	161.0	560001	NODAWAYCO	161.0	1	153	147.2	147.5	4.8%	S1399 to Humboldt	LES0015
635034	CLRND 5	161.0	560001	NODAWAYCO	161.0	1	153	147.2	147.5	4.8%	S1399 to Humboldt	LES0017
635034	CLRND 5	161.0	560001	NODAWAYCO	161.0	1	153	147.1	147.5	4.8%	S1399 to Humboldt	CBFREM-B
635034	CLRND 5	161.0	560001	NODAWAYCO	161.0	1	153	147.1	147.5	4.8%	S1399 to Humboldt	CBFREM-C
635034	CLRND 5	161.0	560001	NODAWAYCO	161.0	1	153	147.2	147.5	4.8%	S1399 to Humboldt	CB906N-69DT2
635034	CLRND 5	161.0	560001	NODAWAYCO	161.0	1	153	147.2	147.5	4.8%	S1399 to Humboldt	BKR-PLN-3310
635034	CLRND 5	161.0	560001	NODAWAYCO	161.0	1	153	147.2	147.5	4.8%	S1399 to Humboldt	LN-1152

635034	CLRND 5	161.0	560001	NODAWAYCO	161.0	1	153	147.2	147.5	4.8%	S1399 to Humboldt	LES0018
635034	CLRND 5	161.0	560001	NODAWAYCO	161.0	1	153	147.2	147.5	4.8%	S1399 to Humboldt	CB3454-55&T1
635034	CLRND 5	161.0	560001	NODAWAYCO	161.0	1	153	147.2	147.5	4.8%	S1399 to Humboldt	CB906N-BT61
635034	CLRND 5	161.0	560001	NODAWAYCO	161.0	1	153	147.2	147.5	4.8%	S1399 to Humboldt	LES1503A
635034	CLRND 5	161.0	560001	NODAWAYCO	161.0	1	153	147.1	147.5	4.8%	S1399 to Humboldt	XS543028>541203>\$1
635034	CLRND 5	161.0	560001	NODAWAYCO	161.0	1	153	147.2	147.5	4.8%	S1399 to Humboldt	XS541241>345409>\$1
635034	CLRND 5	161.0	560001	NODAWAYCO	161.0	1	153	147.2	147.5	4.8%	S1399 to Humboldt	XS541206>541211>\$1
635034	CLRND 5	161.0	560001	NODAWAYCO	161.0	1	153	147.2	147.5	4.8%	S1399 to Humboldt	XS541206>541233>\$1
635034	CLRND 5	161.0	560001	NODAWAYCO	161.0	1	153	147.2	147.5	4.8%	S1399 to Humboldt	XS542973>543027>\$1
635034	CLRND 5	161.0	560001	NODAWAYCO	161.0	1	153	147.2	147.5	4.8%	S1399 to Humboldt	XS541205>541211>\$1
635034	CLRND 5	161.0	560001	NODAWAYCO	161.0	1	153	147.2	147.5	4.8%	S1399 to Humboldt	XS613370>631042>\$1
635034	CLRND 5	161.0	560001	NODAWAYCO	161.0	1	153	147.2	147.5	4.8%	S1399 to Humboldt	XS631002>631010>\$1
635034	CLRND 5	161.0	560001	NODAWAYCO	161.0	1	153	147.2	147.5	4.8%	S1399 to Humboldt	XS631081>631083>\$1
635034	CLRND 5	161.0	560001	NODAWAYCO	161.0	1	153	147.2	147.5	4.8%	S1399 to Humboldt	XS631012>629102>\$1
635034	CLRND 5	161.0	560001	NODAWAYCO	161.0	1	153	147.2	147.5	4.8%	S1399 to Humboldt	XS631043>631045>\$1
635034	CLRND 5	161.0	560001	NODAWAYCO	161.0	1	153	147.2	147.5	4.8%	S1399 to Humboldt	XS543061>543062>\$1
635034	CLRND 5	161.0	560001	NODAWAYCO	161.0	1	153	147.2	147.5	4.8%	S1399 to Humboldt	XS631068>629121>\$1
635034	CLRND 5	161.0	560001	NODAWAYCO	161.0	1	153	147.1	147.5	4.8%	S1399 to Humboldt	XS560142>560143>\$1
635034	CLRND 5	161.0	560001	NODAWAYCO	161.0	1	153	147.2	147.5	4.8%	S1399 to Humboldt	XS631091>629106>\$1
635034	CLRND 5	161.0	560001	NODAWAYCO	161.0	1	153	147.1	147.5	4.8%	S1399 to Humboldt	XS560141>560142>\$1
635034	CLRND 5	161.0	560001	NODAWAYCO	161.0	1	153	147.2	147.5	3.8%	S1280 to Humboldt	XS640277>650114>\$1
635034	CLRND 5	161.0	560001	NODAWAYCO	161.0	1	153	147.2	147.5	3.8%	S1280 to Humboldt	XS532794>532797>\$1
635034	CLRND 5	161.0	560001	NODAWAYCO	161.0	1	153	147.3	147.5	3.8%	S1280 to Humboldt	XS652565>652567>\$1
635034	CLRND 5	161.0	560001	NODAWAYCO	161.0	1	153	147.3	147.5	3.8%	S1280 to Humboldt	XS541253>541258>\$1
635034	CLRND 5	161.0	560001	NODAWAYCO	161.0	1	153	147.2	147.5	3.8%	S1280 to Humboldt	XS541257>541355>\$1
635034	CLRND 5	161.0	560001	NODAWAYCO	161.0	1	153	147.2	147.5	3.8%	S1399 to Humboldt	XS635690>635693>\$3
635034	CLRND 5	161.0	560001	NODAWAYCO	161.0	1	153	147.2	147.5	3.8%	S1399 to Humboldt	XS640074>640075>\$1

635034	CLRND 5	161.0	560001	NODAWAYCO	161.0	1	153	147.2	147.5	3.8%	S1399 to Humboldt	XS640074>640076>\$1
635034	CLRND 5	161.0	560001	NODAWAYCO	161.0	1	153	147.2	147.5	3.8%	S1399 to Humboldt	XS640192>640193>\$1
635034	CLRND 5	161.0	560001	NODAWAYCO	161.0	1	153	147.2	147.5	3.8%	S1399 to Humboldt	XS645100>645104>\$1
635034	CLRND 5	161.0	560001	NODAWAYCO	161.0	1	153	147.2	147.5	3.8%	S1399 to Humboldt	XS640206>640207>\$1
635034	CLRND 5	161.0	560001	NODAWAYCO	161.0	1	153	147.2	147.5	3.8%	S1399 to Humboldt	XS647114>647115>\$1
635034	CLRND 5	161.0	560001	NODAWAYCO	161.0	1	153	147.2	147.5	3.8%	S1399 to Humboldt	XS647112>647964>\$1
635034	CLRND 5	161.0	560001	NODAWAYCO	161.0	1	153	147.2	147.5	3.8%	S1399 to Humboldt	S962-KM-S971
635034	CLRND 5	161.0	560001	NODAWAYCO	161.0	1	153	147.2	147.5	3.8%	S1399 to Humboldt	XS532920>533182>533885\$1
635034	CLRND 5	161.0	560001	NODAWAYCO	161.0	1	153	147.2	147.5	3.8%	S1399 to Humboldt	XS533152>533165>\$1
635034	CLRND 5	161.0	560001	NODAWAYCO	161.0	1	153	147.2	147.5	3.8%	S1399 to Humboldt	XS659236>659237>\$1
635034	CLRND 5	161.0	560001	NODAWAYCO	161.0	1	153	147.2	147.5	3.8%	S1399 to Humboldt	LES6703
635034	CLRND 5	161.0	560001	NODAWAYCO	161.0	1	153	147.2	147.5	3.8%	S1399 to Humboldt	CB1201-29&86
635034	CLRND 5	161.0	560001	NODAWAYCO	161.0	1	153	147.2	147.5	3.8%	S1399 to Humboldt	LN-1156
635034	CLRND 5	161.0	560001	NODAWAYCO	161.0	1	153	147.2	147.5	3.8%	S1399 to Humboldt	XS541215>541247>\$1
635034	CLRND 5	161.0	560001	NODAWAYCO	161.0	1	153	147.1	147.5	3.8%	S1399 to Humboldt	XS541215>541250>\$1
635034	CLRND 5	161.0	560001	NODAWAYCO	161.0	1	153	147.2	147.5	3.8%	S1399 to Humboldt	XS541250>548808>\$1
635034	CLRND 5	161.0	560001	NODAWAYCO	161.0	1	153	147.2	147.5	3.8%	S1399 to Humboldt	XS541218>541233>\$1
635034	CLRND 5	161.0	560001	NODAWAYCO	161.0	1	153	147.2	147.5	3.8%	S1399 to Humboldt	XS631085>629099>\$1
635034	CLRND 5	161.0	560001	NODAWAYCO	161.0	1	153	147.2	147.5	3.8%	S1399 to Humboldt	XS613370>631043>\$1
635034	CLRND 5	161.0	560001	NODAWAYCO	161.0	1	153	147.3	147.5	3.8%	S975 (Humboldt) T4 161-69	XS640125>650114>\$1
635034	CLRND 5	161.0	560001	NODAWAYCO	161.0	1	153	147.3	147.5	3.8%	S975 (Humboldt) T4 161-69	TWR-ETR-SP
635034	CLRND 5	161.0	560001	NODAWAYCO	161.0	1	153	147.2	147.5	3.8%	S1280 to Humboldt	XS640088>640024>\$1
635034	CLRND 5	161.0	560001	NODAWAYCO	161.0	1	153	147.2	147.5	3.8%	S1280 to Humboldt	XS646258>646263>\$1
635034	CLRND 5	161.0	560001	NODAWAYCO	161.0	1	153	147.2	147.5	3.8%	S1280 to Humboldt	XS646244>646258>\$1
635034	CLRND 5	161.0	560001	NODAWAYCO	161.0	1	153	147.3	147.5	3.8%	S1280 to Humboldt	CB1206-16&T4
635034	CLRND 5	161.0	560001	NODAWAYCO	161.0	1	153	147.2	147.5	3.8%	S1399 to Humboldt	XS631097>629094>\$1
635034	CLRND 5	161.0	560001	NODAWAYCO	161.0	1	153	147.2	147.5	3.8%	S1399 to Humboldt	XS635653>635654>\$1

635034	CLRND 5	161.0	560001	NODAWAYCO	161.0	1	153	147.2	147.5	3.8%	S1399 to Humboldt	XS640397>640398>\$1
635034	CLRND 5	161.0	560001	NODAWAYCO	161.0	1	153	147.2	147.5	3.8%	S1399 to Humboldt	XS640256>640257>\$1
635034	CLRND 5	161.0	560001	NODAWAYCO	161.0	1	153	147.2	147.5	3.8%	S1399 to Humboldt	XS640375>640376>\$1
635034	CLRND 5	161.0	560001	NODAWAYCO	161.0	1	153	147.2	147.5	3.8%	S1399 to Humboldt	XS646222>646229>\$1
635034	CLRND 5	161.0	560001	NODAWAYCO	161.0	1	153	147.2	147.5	3.8%	S1399 to Humboldt	XS300042>300045>\$1
635034	CLRND 5	161.0	560001	NODAWAYCO	161.0	1	153	147.2	147.5	3.8%	S1399 to Humboldt	XS533163>533199>\$1
635034	CLRND 5	161.0	560001	NODAWAYCO	161.0	1	153	147.2	147.5	3.8%	S1399 to Humboldt	XS533165>533199>\$1
635034	CLRND 5	161.0	560001	NODAWAYCO	161.0	1	153	147.2	147.5	3.8%	S1399 to Humboldt	1297TARP
635034	CLRND 5	161.0	560001	NODAWAYCO	161.0	1	153	147.2	147.5	3.8%	S1399 to Humboldt	XS631001>631004>\$1
635034	CLRND 5	161.0	560001	NODAWAYCO	161.0	1	153	147.3	147.5	3.8%	S975 (Humboldt) T4 161-69	XS650290>650092>\$1
635034	CLRND 5	161.0	560001	NODAWAYCO	161.0	1	153	147.3	147.5	3.8%	S975 (Humboldt) T4 161-69	LES9001
635034	CLRND 5	161.0	560001	NODAWAYCO	161.0	1	153	147.3	147.5	3.8%	S975 (Humboldt) T4 161-69	BKR-HLD-3003
635034	CLRND 5	161.0	560001	NODAWAYCO	161.0	1	153	147.1	147.4	4.8%	S1399 to Humboldt	XS635601>635608>\$1
635034	CLRND 5	161.0	560001	NODAWAYCO	161.0	1	153	147.1	147.4	4.8%	S1399 to Humboldt	XS635633>638050>\$1
635034	CLRND 5	161.0	560001	NODAWAYCO	161.0	1	153	147.1	147.4	4.8%	S1399 to Humboldt	XS640169>640170>\$1
635034	CLRND 5	161.0	560001	NODAWAYCO	161.0	1	153	147.1	147.4	4.8%	S1399 to Humboldt	XS640171>640172>\$1
635034	CLRND 5	161.0	560001	NODAWAYCO	161.0	1	153	147.1	147.4	4.8%	S1399 to Humboldt	XS636230>636235>\$1
635034	CLRND 5	161.0	560001	NODAWAYCO	161.0	1	153	147.1	147.4	4.8%	S1399 to Humboldt	XS636620>636630>\$1
635034	CLRND 5	161.0	560001	NODAWAYCO	161.0	1	153	147.1	147.4	4.8%	S1399 to Humboldt	XS640167>640168>\$1
635034	CLRND 5	161.0	560001	NODAWAYCO	161.0	1	153	147.1	147.4	4.8%	S1399 to Humboldt	XS640178>640179>\$1
635034	CLRND 5	161.0	560001	NODAWAYCO	161.0	1	153	147	147.4	4.8%	S1399 to Humboldt	XS640080>640081>\$1
635034	CLRND 5	161.0	560001	NODAWAYCO	161.0	1	153	147.1	147.4	4.8%	S1399 to Humboldt	XS640377>646226>\$1
635034	CLRND 5	161.0	560001	NODAWAYCO	161.0	1	153	147.1	147.4	4.8%	S1399 to Humboldt	XS645011>645112>\$1
635034	CLRND 5	161.0	560001	NODAWAYCO	161.0	1	153	147.1	147.4	4.8%	S1399 to Humboldt	XS640224>640310>\$1
635034	CLRND 5	161.0	560001	NODAWAYCO	161.0	1	153	147.1	147.4	4.8%	S1399 to Humboldt	XS645011>645111>\$1
635034	CLRND 5	161.0	560001	NODAWAYCO	161.0	1	153	147.1	147.4	4.8%	S1399 to Humboldt	XS640310>640311>\$1
635034	CLRND 5	161.0	560001	NODAWAYCO	161.0	1	153	147.1	147.4	4.8%	S1399 to Humboldt	XS640413>640414>\$1

635034	CLRNDA 5	161.0	560001	NODAWAYCO	161.0	1	153	147.1	147.4	4.8%	S1399 to Humboldt	XS640407>640408>\$1
635034	CLRNDA 5	161.0	560001	NODAWAYCO	161.0	1	153	147.1	147.4	4.8%	S1399 to Humboldt	XS640244>640245>\$1
635034	CLRNDA 5	161.0	560001	NODAWAYCO	161.0	1	153	147.1	147.4	4.8%	S1399 to Humboldt	XS640287>640289>\$1
635034	CLRNDA 5	161.0	560001	NODAWAYCO	161.0	1	153	147.1	147.4	4.8%	S1399 to Humboldt	XS640287>640288>\$1
635034	CLRNDA 5	161.0	560001	NODAWAYCO	161.0	1	153	147.1	147.4	4.8%	S1399 to Humboldt	XS641084>641097>\$1
635034	CLRNDA 5	161.0	560001	NODAWAYCO	161.0	1	153	147.1	147.4	4.8%	S1399 to Humboldt	XS640284>640285>\$1
635034	CLRNDA 5	161.0	560001	NODAWAYCO	161.0	1	153	147.1	147.4	4.8%	S1399 to Humboldt	XS640248>640249>\$1
635034	CLRNDA 5	161.0	560001	NODAWAYCO	161.0	1	153	147.1	147.4	4.8%	S1399 to Humboldt	XS640328>640417>\$1
635034	CLRNDA 5	161.0	560001	NODAWAYCO	161.0	1	153	147.1	147.4	4.8%	S1399 to Humboldt	XS640338>640339>\$2
635034	CLRNDA 5	161.0	560001	NODAWAYCO	161.0	1	153	147.1	147.4	4.8%	S1399 to Humboldt	XS640365>640366>\$1
635034	CLRNDA 5	161.0	560001	NODAWAYCO	161.0	1	153	147.1	147.4	4.8%	S1399 to Humboldt	XS640196>640197>\$1
635034	CLRNDA 5	161.0	560001	NODAWAYCO	161.0	1	153	147.1	147.4	4.8%	S1399 to Humboldt	XS650255>650355>650555\$1
635034	CLRNDA 5	161.0	560001	NODAWAYCO	161.0	1	153	147.1	147.4	4.8%	S1399 to Humboldt	XS650267>650467>650667\$1
635034	CLRNDA 5	161.0	560001	NODAWAYCO	161.0	1	153	147.1	147.4	4.8%	S1399 to Humboldt	XS650233>650333>650533\$1
635034	CLRNDA 5	161.0	560001	NODAWAYCO	161.0	1	153	147.1	147.4	4.8%	S1399 to Humboldt	XS647108>647110>\$1
635034	CLRNDA 5	161.0	560001	NODAWAYCO	161.0	1	153	147.1	147.4	4.8%	S1399 to Humboldt	XS650271>650371>650571\$1
635034	CLRNDA 5	161.0	560001	NODAWAYCO	161.0	1	153	147.1	147.4	4.8%	S1399 to Humboldt	XS650256>650356>650556\$1
635034	CLRNDA 5	161.0	560001	NODAWAYCO	161.0	1	153	147.1	147.4	4.8%	S1399 to Humboldt	XS647964>647975>\$1
635034	CLRNDA 5	161.0	560001	NODAWAYCO	161.0	1	153	147.1	147.4	4.8%	S1399 to Humboldt	XS650256>650456>650656\$1
635034	CLRNDA 5	161.0	560001	NODAWAYCO	161.0	1	153	147.1	147.4	4.8%	S1399 to Humboldt	XS650114>650185>\$1
635034	CLRNDA 5	161.0	560001	NODAWAYCO	161.0	1	153	147.1	147.4	4.8%	S1399 to Humboldt	XS650238>650338>650538\$1
635034	CLRNDA 5	161.0	560001	NODAWAYCO	161.0	1	153	147.1	147.4	4.8%	S1399 to Humboldt	XS650238>650438>650638\$1
635034	CLRNDA 5	161.0	560001	NODAWAYCO	161.0	1	153	147.1	147.4	4.8%	S1399 to Humboldt	XS650260>650360>650560\$1
635034	CLRNDA 5	161.0	560001	NODAWAYCO	161.0	1	153	147.1	147.4	4.8%	S1399 to Humboldt	XS650260>650460>650660\$1
635034	CLRNDA 5	161.0	560001	NODAWAYCO	161.0	1	153	147.1	147.4	4.8%	S1399 to Humboldt	XS650217>650417>650617\$1
635034	CLRNDA 5	161.0	560001	NODAWAYCO	161.0	1	153	147.1	147.4	4.8%	S1399 to Humboldt	XS650217>650317>650517\$1
635034	CLRNDA 5	161.0	560001	NODAWAYCO	161.0	1	153	147.1	147.4	4.8%	S1399 to Humboldt	S937NOBKR

635034	CLRND 5	161.0	560001	NODAWAYCO	161.0	1	153	147	147.4	4.8%	S1399 to Humboldt	MC1299SOUTH
635034	CLRND 5	161.0	560001	NODAWAYCO	161.0	1	153	147.1	147.4	4.8%	S1399 to Humboldt	S964-S993
635034	CLRND 5	161.0	560001	NODAWAYCO	161.0	1	153	147.1	147.4	4.8%	S1399 to Humboldt	XS300048>300051>\$1
635034	CLRND 5	161.0	560001	NODAWAYCO	161.0	1	153	147.1	147.4	4.8%	S1399 to Humboldt	XS300041>344327>\$1
635034	CLRND 5	161.0	560001	NODAWAYCO	161.0	1	153	147.1	147.4	4.8%	S1399 to Humboldt	XS300048>300116>\$1
635034	CLRND 5	161.0	560001	NODAWAYCO	161.0	1	153	147.1	147.4	4.8%	S1399 to Humboldt	XS300046>300051>\$1
635034	CLRND 5	161.0	560001	NODAWAYCO	161.0	1	153	147.1	147.4	4.8%	S1399 to Humboldt	MC906-79-28
635034	CLRND 5	161.0	560001	NODAWAYCO	161.0	1	153	147.1	147.4	4.8%	S1399 to Humboldt	XS300116>300011>\$2
635034	CLRND 5	161.0	560001	NODAWAYCO	161.0	1	153	147.1	147.4	4.8%	S1399 to Humboldt	XS300114>300115>\$1
635034	CLRND 5	161.0	560001	NODAWAYCO	161.0	1	153	147.1	147.4	4.8%	S1399 to Humboldt	XS300114>300010>\$1
635034	CLRND 5	161.0	560001	NODAWAYCO	161.0	1	153	147.1	147.4	4.8%	S1399 to Humboldt	XS532768>532774>\$1
635034	CLRND 5	161.0	560001	NODAWAYCO	161.0	1	153	147.1	147.4	4.8%	S1399 to Humboldt	XS532793>510380>\$1
635034	CLRND 5	161.0	560001	NODAWAYCO	161.0	1	153	147.1	147.4	4.8%	S1399 to Humboldt	XS533152>533331>\$1
635034	CLRND 5	161.0	560001	NODAWAYCO	161.0	1	153	147.1	147.4	4.8%	S1399 to Humboldt	XS652626>659292>\$1
635034	CLRND 5	161.0	560001	NODAWAYCO	161.0	1	153	147	147.4	4.8%	S1399 to Humboldt	XS652536>652287>\$1
635034	CLRND 5	161.0	560001	NODAWAYCO	161.0	1	153	147.1	147.4	4.8%	S1399 to Humboldt	XS652531>652242>\$1
635034	CLRND 5	161.0	560001	NODAWAYCO	161.0	1	153	147.1	147.4	4.8%	S1399 to Humboldt	XS652506>652571>\$1
635034	CLRND 5	161.0	560001	NODAWAYCO	161.0	1	153	147.1	147.4	4.8%	S1399 to Humboldt	XS652504>652225>\$1
635034	CLRND 5	161.0	560001	NODAWAYCO	161.0	1	153	147.1	147.4	4.8%	S1399 to Humboldt	XS659240>659301>\$1
635034	CLRND 5	161.0	560001	NODAWAYCO	161.0	1	153	147.1	147.4	4.8%	S1399 to Humboldt	XS652516>652277>\$1
635034	CLRND 5	161.0	560001	NODAWAYCO	161.0	1	153	147.1	147.4	4.8%	S1399 to Humboldt	XS652518>652251>\$1
635034	CLRND 5	161.0	560001	NODAWAYCO	161.0	1	153	147.1	147.4	4.8%	S1399 to Humboldt	D-CIRCUIT#15
635034	CLRND 5	161.0	560001	NODAWAYCO	161.0	1	153	147.1	147.4	4.8%	S1399 to Humboldt	D-CIRCUIT#13
635034	CLRND 5	161.0	560001	NODAWAYCO	161.0	1	153	147.1	147.4	4.8%	S1399 to Humboldt	CB1206-16&T1
635034	CLRND 5	161.0	560001	NODAWAYCO	161.0	1	153	147.1	147.4	4.8%	S1399 to Humboldt	LES3805B
635034	CLRND 5	161.0	560001	NODAWAYCO	161.0	1	153	147.1	147.4	4.8%	S1399 to Humboldt	D-CIRCUIT#2B
635034	CLRND 5	161.0	560001	NODAWAYCO	161.0	1	153	147.1	147.4	4.8%	S1399 to Humboldt	LES6705

635034	CLRNDA 5	161.0	560001	NODAWAYCO	161.0	1	153	147.1	147.4	4.8%	S1399 to Humboldt	CB1259-BUS81
635034	CLRNDA 5	161.0	560001	NODAWAYCO	161.0	1	153	147.1	147.4	4.8%	S1399 to Humboldt	MC1201-20-86
635034	CLRNDA 5	161.0	560001	NODAWAYCO	161.0	1	153	147.1	147.4	4.8%	S1399 to Humboldt	LN-N-BEND
635034	CLRNDA 5	161.0	560001	NODAWAYCO	161.0	1	153	147.1	147.4	4.8%	S1399 to Humboldt	CBFREM-E
635034	CLRNDA 5	161.0	560001	NODAWAYCO	161.0	1	153	147.1	147.4	4.8%	S1399 to Humboldt	CB906N-6979
635034	CLRNDA 5	161.0	560001	NODAWAYCO	161.0	1	153	147.1	147.4	4.8%	S1399 to Humboldt	906N15-25-94
635034	CLRNDA 5	161.0	560001	NODAWAYCO	161.0	1	153	147.1	147.4	4.8%	S1399 to Humboldt	CB984-BUS991
635034	CLRNDA 5	161.0	560001	NODAWAYCO	161.0	1	153	147.1	147.4	4.8%	S1399 to Humboldt	CBTEK-BUS
635034	CLRNDA 5	161.0	560001	NODAWAYCO	161.0	1	153	147.1	147.4	4.8%	S1399 to Humboldt	CB985-BUS
635034	CLRNDA 5	161.0	560001	NODAWAYCO	161.0	1	153	147.1	147.4	4.8%	S1399 to Humboldt	CB994-BUS06N
635034	CLRNDA 5	161.0	560001	NODAWAYCO	161.0	1	153	147.1	147.4	4.8%	S1399 to Humboldt	LES0013
635034	CLRNDA 5	161.0	560001	NODAWAYCO	161.0	1	153	147.1	147.4	4.8%	S1399 to Humboldt	XS542965>542966>543649\$11
635034	CLRNDA 5	161.0	560001	NODAWAYCO	161.0	1	153	147.1	147.4	4.8%	S1399 to Humboldt	XS543015>543016>\$1
635034	CLRNDA 5	161.0	560001	NODAWAYCO	161.0	1	153	147.1	147.4	4.8%	S1399 to Humboldt	XS542968>541198>\$1
635034	CLRNDA 5	161.0	560001	NODAWAYCO	161.0	1	153	147.1	147.4	4.8%	S1399 to Humboldt	XS543062>300120>\$1
635034	CLRNDA 5	161.0	560001	NODAWAYCO	161.0	1	153	147.1	147.4	4.8%	S1399 to Humboldt	XS631013>631014>\$1
635034	CLRNDA 5	161.0	560001	NODAWAYCO	161.0	1	153	147.1	147.4	4.8%	S1399 to Humboldt	XS631073>629095>\$1
635034	CLRNDA 5	161.0	560001	NODAWAYCO	161.0	1	153	147.1	147.4	4.8%	S1399 to Humboldt	XS631071>629111>\$1
635034	CLRNDA 5	161.0	560001	NODAWAYCO	161.0	1	153	147.1	147.4	4.8%	S1399 to Humboldt	XS631063>630174>\$1
635034	CLRNDA 5	161.0	560001	NODAWAYCO	161.0	1	153	147.1	147.4	4.8%	S1399 to Humboldt	XS631074>631077>\$1
635034	CLRNDA 5	161.0	560001	NODAWAYCO	161.0	1	153	147.1	147.4	3.8%	S1280 to Humboldt	XS640088>640022>\$1
635034	CLRNDA 5	161.0	560001	NODAWAYCO	161.0	1	153	147.1	147.4	3.8%	S1280 to Humboldt	XS640088>640023>\$1
635034	CLRNDA 5	161.0	560001	NODAWAYCO	161.0	1	153	147.1	147.4	3.8%	S1280 to Humboldt	XS640125>650114>\$1
635034	CLRNDA 5	161.0	560001	NODAWAYCO	161.0	1	153	147.1	147.4	3.8%	S1280 to Humboldt	XS640278>640019>\$1
635034	CLRNDA 5	161.0	560001	NODAWAYCO	161.0	1	153	147.1	147.4	3.8%	S1280 to Humboldt	XS300097>300258>\$1
635034	CLRNDA 5	161.0	560001	NODAWAYCO	161.0	1	153	147.1	147.4	3.8%	S1280 to Humboldt	XS652541>652545>\$1
635034	CLRNDA 5	161.0	560001	NODAWAYCO	161.0	1	153	147.2	147.4	3.8%	S1280 to Humboldt	LES9004B

635034	CLRND 5	161.0	560001	NODAWAYCO	161.0	1	153	147.1	147.4	3.8%	S1280 to Humboldt	BKR-MOR-3312
635034	CLRND 5	161.0	560001	NODAWAYCO	161.0	1	153	147.2	147.4	3.8%	S1280 to Humboldt	XS541254>541258>\$1
635034	CLRND 5	161.0	560001	NODAWAYCO	161.0	1	153	147.1	147.4	3.8%	S1399 to Humboldt	XS631107>635710>\$1
635034	CLRND 5	161.0	560001	NODAWAYCO	161.0	1	153	147.1	147.4	3.8%	S1399 to Humboldt	XS636050>636235>\$1
635034	CLRND 5	161.0	560001	NODAWAYCO	161.0	1	153	147	147.4	3.8%	S1399 to Humboldt	XS640051>640052>\$1
635034	CLRND 5	161.0	560001	NODAWAYCO	161.0	1	153	147.1	147.4	3.8%	S1399 to Humboldt	XS640355>640356>\$1
635034	CLRND 5	161.0	560001	NODAWAYCO	161.0	1	153	147.1	147.4	3.8%	S1399 to Humboldt	XS645100>646251>\$1
635034	CLRND 5	161.0	560001	NODAWAYCO	161.0	1	153	147.1	147.4	3.8%	S1399 to Humboldt	XS640293>640295>\$1
635034	CLRND 5	161.0	560001	NODAWAYCO	161.0	1	153	147.1	147.4	3.8%	S1399 to Humboldt	XS640411>640412>\$1
635034	CLRND 5	161.0	560001	NODAWAYCO	161.0	1	153	147.1	147.4	3.8%	S1399 to Humboldt	XS640265>640266>\$1
635034	CLRND 5	161.0	560001	NODAWAYCO	161.0	1	153	147.1	147.4	3.8%	S1399 to Humboldt	XS640353>640355>\$1
635034	CLRND 5	161.0	560001	NODAWAYCO	161.0	1	153	147	147.4	3.8%	S1399 to Humboldt	XS640400>640401>\$1
635034	CLRND 5	161.0	560001	NODAWAYCO	161.0	1	153	147.1	147.4	3.8%	S1399 to Humboldt	XS650258>650358>650558\$1
635034	CLRND 5	161.0	560001	NODAWAYCO	161.0	1	153	147.1	147.4	3.8%	S1399 to Humboldt	XS650258>650458>650658\$1
635034	CLRND 5	161.0	560001	NODAWAYCO	161.0	1	153	147	147.4	3.8%	S1399 to Humboldt	XS650205>650305>650505\$1
635034	CLRND 5	161.0	560001	NODAWAYCO	161.0	1	153	147.1	147.4	3.8%	S1399 to Humboldt	XS652397>659258>\$1
635034	CLRND 5	161.0	560001	NODAWAYCO	161.0	1	153	147	147.4	3.8%	S1399 to Humboldt	MC3456-59-16
635034	CLRND 5	161.0	560001	NODAWAYCO	161.0	1	153	147	147.4	3.8%	S1399 to Humboldt	XS300098>300304>548824\$2
635034	CLRND 5	161.0	560001	NODAWAYCO	161.0	1	153	147	147.4	3.8%	S1399 to Humboldt	XS300098>300304>548823\$1
635034	CLRND 5	161.0	560001	NODAWAYCO	161.0	1	153	147.1	147.4	3.8%	S1399 to Humboldt	XS533217>533331>\$1
635034	CLRND 5	161.0	560001	NODAWAYCO	161.0	1	153	147	147.4	3.8%	S1399 to Humboldt	XS652614>659196>\$1
635034	CLRND 5	161.0	560001	NODAWAYCO	161.0	1	153	147.1	147.4	3.8%	S1399 to Humboldt	XS652515>652284>\$1
635034	CLRND 5	161.0	560001	NODAWAYCO	161.0	1	153	147	147.4	3.8%	S1399 to Humboldt	LES3802A
635034	CLRND 5	161.0	560001	NODAWAYCO	161.0	1	153	147.1	147.4	3.8%	S1399 to Humboldt	CB1226-98&TK
635034	CLRND 5	161.0	560001	NODAWAYCO	161.0	1	153	147.1	147.4	3.8%	S1399 to Humboldt	BKR-MOR-3304
635034	CLRND 5	161.0	560001	NODAWAYCO	161.0	1	153	147	147.4	3.8%	S1399 to Humboldt	CB1299-BUS
635034	CLRND 5	161.0	560001	NODAWAYCO	161.0	1	153	147	147.4	3.8%	S1399 to Humboldt	CB975-93-AUB

635034	CLRND 5	161.0	560001	NODAWAYCO	161.0	1	153	147.1	147.4	3.8%	S1399 to Humboldt	XS543062>543064>\$1
635034	CLRND 5	161.0	560001	NODAWAYCO	161.0	1	153	147.1	147.4	3.8%	S1399 to Humboldt	XS631062>630175>\$1
635034	CLRND 5	161.0	560001	NODAWAYCO	161.0	1	153	147.2	147.4	3.8%	S975 (Humboldt) T4 161-69	XS640278>640020>\$1
635034	CLRND 5	161.0	560001	NODAWAYCO	161.0	1	153	147	147.3	4.8%	S1399 to Humboldt	XS635039>635041>\$1
635034	CLRND 5	161.0	560001	NODAWAYCO	161.0	1	153	147	147.3	4.8%	S1399 to Humboldt	XS635041>638050>\$1
635034	CLRND 5	161.0	560001	NODAWAYCO	161.0	1	153	146.9	147.3	4.8%	S1399 to Humboldt	XS631117>635670>\$1
635034	CLRND 5	161.0	560001	NODAWAYCO	161.0	1	153	147	147.3	4.8%	S1399 to Humboldt	XS636001>636050>\$1
635034	CLRND 5	161.0	560001	NODAWAYCO	161.0	1	153	147	147.3	4.8%	S1399 to Humboldt	XS631110>631111>\$1
635034	CLRND 5	161.0	560001	NODAWAYCO	161.0	1	153	147	147.3	4.8%	S1399 to Humboldt	XS631110>631115>\$1
635034	CLRND 5	161.0	560001	NODAWAYCO	161.0	1	153	146.9	147.3	4.8%	S1399 to Humboldt	XS635640>635650>\$1
635034	CLRND 5	161.0	560001	NODAWAYCO	161.0	1	153	146.9	147.3	4.8%	S1399 to Humboldt	XS635003>635005>\$1
635034	CLRND 5	161.0	560001	NODAWAYCO	161.0	1	153	147	147.3	4.8%	S1399 to Humboldt	XS640098>640099>\$1
635034	CLRND 5	161.0	560001	NODAWAYCO	161.0	1	153	147	147.3	4.8%	S1399 to Humboldt	XS636230>636240>\$1
635034	CLRND 5	161.0	560001	NODAWAYCO	161.0	1	153	147	147.3	4.8%	S1399 to Humboldt	XS636225>636240>\$1
635034	CLRND 5	161.0	560001	NODAWAYCO	161.0	1	153	147	147.3	4.8%	S1399 to Humboldt	XS640063>640416>\$1
635034	CLRND 5	161.0	560001	NODAWAYCO	161.0	1	153	147	147.3	4.8%	S1399 to Humboldt	XS640072>640073>\$1
635034	CLRND 5	161.0	560001	NODAWAYCO	161.0	1	153	147	147.3	4.8%	S1399 to Humboldt	XS636635>636640>\$1
635034	CLRND 5	161.0	560001	NODAWAYCO	161.0	1	153	146.9	147.3	4.8%	S1399 to Humboldt	XS640212>640213>\$1
635034	CLRND 5	161.0	560001	NODAWAYCO	161.0	1	153	147	147.3	4.8%	S1399 to Humboldt	XS640372>640373>\$1
635034	CLRND 5	161.0	560001	NODAWAYCO	161.0	1	153	147	147.3	4.8%	S1399 to Humboldt	XS645025>645125>\$1
635034	CLRND 5	161.0	560001	NODAWAYCO	161.0	1	153	147	147.3	4.8%	S1399 to Humboldt	XS640261>640262>\$1
635034	CLRND 5	161.0	560001	NODAWAYCO	161.0	1	153	147	147.3	4.8%	S1399 to Humboldt	XS640293>640294>\$1
635034	CLRND 5	161.0	560001	NODAWAYCO	161.0	1	153	147	147.3	4.8%	S1399 to Humboldt	XS640246>652302>\$1
635034	CLRND 5	161.0	560001	NODAWAYCO	161.0	1	153	147	147.3	4.8%	S1399 to Humboldt	XS640331>640332>\$1
635034	CLRND 5	161.0	560001	NODAWAYCO	161.0	1	153	147	147.3	4.8%	S1399 to Humboldt	XS645061>648500>\$1
635034	CLRND 5	161.0	560001	NODAWAYCO	161.0	1	153	147	147.3	4.8%	S1399 to Humboldt	XS650230>650430>650630\$1
635034	CLRND 5	161.0	560001	NODAWAYCO	161.0	1	153	147	147.3	4.8%	S1399 to Humboldt	XS650270>650370>650570\$1

635034	CLRND 5	161.0	560001	NODAWAYCO	161.0	1	153	147	147.3	4.8%	S1399 to Humboldt	XS650238>650251>\$1
635034	CLRND 5	161.0	560001	NODAWAYCO	161.0	1	153	147	147.3	4.8%	S1399 to Humboldt	XS650230>650330>\$1
635034	CLRND 5	161.0	560001	NODAWAYCO	161.0	1	153	147	147.3	4.8%	S1399 to Humboldt	XS650229>650329>650529\$1
635034	CLRND 5	161.0	560001	NODAWAYCO	161.0	1	153	147	147.3	4.8%	S1399 to Humboldt	XS646214>646287>\$1
635034	CLRND 5	161.0	560001	NODAWAYCO	161.0	1	153	147	147.3	4.8%	S1399 to Humboldt	XS650259>650359>650559\$1
635034	CLRND 5	161.0	560001	NODAWAYCO	161.0	1	153	147	147.3	4.8%	S1399 to Humboldt	XS647016>647915>\$1
635034	CLRND 5	161.0	560001	NODAWAYCO	161.0	1	153	147	147.3	4.8%	S1399 to Humboldt	XS650252>650352>650552\$1
635034	CLRND 5	161.0	560001	NODAWAYCO	161.0	1	153	147	147.3	4.8%	S1399 to Humboldt	XS650251>650351>650551\$1
635034	CLRND 5	161.0	560001	NODAWAYCO	161.0	1	153	147	147.3	4.8%	S1399 to Humboldt	XS650240>650252>\$1
635034	CLRND 5	161.0	560001	NODAWAYCO	161.0	1	153	147	147.3	4.8%	S1399 to Humboldt	XS647100>647900>\$1
635034	CLRND 5	161.0	560001	NODAWAYCO	161.0	1	153	147	147.3	4.8%	S1399 to Humboldt	XS650219>650319>650519\$1
635034	CLRND 5	161.0	560001	NODAWAYCO	161.0	1	153	147	147.3	4.8%	S1399 to Humboldt	XS650218>650318>650518\$1
635034	CLRND 5	161.0	560001	NODAWAYCO	161.0	1	153	147	147.3	4.8%	S1399 to Humboldt	XS652302>659240>\$1
635034	CLRND 5	161.0	560001	NODAWAYCO	161.0	1	153	147	147.3	4.8%	S1399 to Humboldt	XS300076>300107>\$1
635034	CLRND 5	161.0	560001	NODAWAYCO	161.0	1	153	147	147.3	4.8%	S1399 to Humboldt	XS300040>300054>\$1
635034	CLRND 5	161.0	560001	NODAWAYCO	161.0	1	153	147	147.3	4.8%	S1399 to Humboldt	XS532774>542965>\$1
635034	CLRND 5	161.0	560001	NODAWAYCO	161.0	1	153	147	147.3	4.8%	S1399 to Humboldt	XS532800>532801>\$1
635034	CLRND 5	161.0	560001	NODAWAYCO	161.0	1	153	147	147.3	4.8%	S1399 to Humboldt	XS659162>659243>\$1
635034	CLRND 5	161.0	560001	NODAWAYCO	161.0	1	153	147	147.3	4.8%	S1399 to Humboldt	XS652525>652286>\$1
635034	CLRND 5	161.0	560001	NODAWAYCO	161.0	1	153	147	147.3	4.8%	S1399 to Humboldt	XS652524>659250>\$1
635034	CLRND 5	161.0	560001	NODAWAYCO	161.0	1	153	147	147.3	4.8%	S1399 to Humboldt	XS652503>652224>\$1
635034	CLRND 5	161.0	560001	NODAWAYCO	161.0	1	153	147	147.3	4.8%	S1399 to Humboldt	LES0009
635034	CLRND 5	161.0	560001	NODAWAYCO	161.0	1	153	147	147.3	4.8%	S1399 to Humboldt	LES3301
635034	CLRND 5	161.0	560001	NODAWAYCO	161.0	1	153	147	147.3	4.8%	S1399 to Humboldt	D-CIRCUIT#1B
635034	CLRND 5	161.0	560001	NODAWAYCO	161.0	1	153	147	147.3	4.8%	S1399 to Humboldt	LES3003B
635034	CLRND 5	161.0	560001	NODAWAYCO	161.0	1	153	147	147.3	4.8%	S1399 to Humboldt	D-CIR #14A
635034	CLRND 5	161.0	560001	NODAWAYCO	161.0	1	153	147	147.3	4.8%	S1399 to Humboldt	LES3002

635034	CLRND 5	161.0	560001	NODAWAYCO	161.0	1	153	147	147.3	4.8%	S1399 to Humboldt	CB1341-BUS
635034	CLRND 5	161.0	560001	NODAWAYCO	161.0	1	153	147	147.3	4.8%	S1399 to Humboldt	LES3803A
635034	CLRND 5	161.0	560001	NODAWAYCO	161.0	1	153	147	147.3	4.8%	S1399 to Humboldt	LES6202
635034	CLRND 5	161.0	560001	NODAWAYCO	161.0	1	153	147	147.3	4.8%	S1399 to Humboldt	LES3806B
635034	CLRND 5	161.0	560001	NODAWAYCO	161.0	1	153	147	147.3	4.8%	S1399 to Humboldt	LES6201
635034	CLRND 5	161.0	560001	NODAWAYCO	161.0	1	153	147	147.3	4.8%	S1399 to Humboldt	LN-1161
635034	CLRND 5	161.0	560001	NODAWAYCO	161.0	1	153	147	147.3	4.8%	S1399 to Humboldt	CB902-BUS
635034	CLRND 5	161.0	560001	NODAWAYCO	161.0	1	153	147	147.3	4.8%	S1399 to Humboldt	CB906N-6994
635034	CLRND 5	161.0	560001	NODAWAYCO	161.0	1	153	147	147.3	4.8%	S1399 to Humboldt	LES0014
635034	CLRND 5	161.0	560001	NODAWAYCO	161.0	1	153	147	147.3	4.8%	S1399 to Humboldt	LES1502
635034	CLRND 5	161.0	560001	NODAWAYCO	161.0	1	153	147	147.3	4.8%	S1399 to Humboldt	BKR-WAG-3004
635034	CLRND 5	161.0	560001	NODAWAYCO	161.0	1	153	147	147.3	4.8%	S1399 to Humboldt	XS631081>631107>\$1
635034	CLRND 5	161.0	560001	NODAWAYCO	161.0	1	153	147	147.3	3.8%	S1280 to Humboldt	XS631166>631171>\$1
635034	CLRND 5	161.0	560001	NODAWAYCO	161.0	1	153	147	147.3	3.8%	S1280 to Humboldt	XS636610>270866>\$1
635034	CLRND 5	161.0	560001	NODAWAYCO	161.0	1	153	147.1	147.3	3.8%	S1280 to Humboldt	XS640278>640020>\$1
635034	CLRND 5	161.0	560001	NODAWAYCO	161.0	1	153	147	147.3	3.8%	S1280 to Humboldt	XS640234>647975>648275\$1
635034	CLRND 5	161.0	560001	NODAWAYCO	161.0	1	153	147	147.3	3.8%	S1280 to Humboldt	XS650275>650004>\$1
635034	CLRND 5	161.0	560001	NODAWAYCO	161.0	1	153	147	147.3	3.8%	S1280 to Humboldt	XS650275>650003>\$1
635034	CLRND 5	161.0	560001	NODAWAYCO	161.0	1	153	147	147.3	3.8%	S1280 to Humboldt	XS647963>647977>\$1
635034	CLRND 5	161.0	560001	NODAWAYCO	161.0	1	153	147.1	147.3	3.8%	S1280 to Humboldt	XS300098>344558>\$1
635034	CLRND 5	161.0	560001	NODAWAYCO	161.0	1	153	147	147.3	3.8%	S1280 to Humboldt	XS532873>530592>\$1
635034	CLRND 5	161.0	560001	NODAWAYCO	161.0	1	153	147.1	147.3	3.8%	S1280 to Humboldt	XS532793>300045>\$1
635034	CLRND 5	161.0	560001	NODAWAYCO	161.0	1	153	147	147.3	3.8%	S1280 to Humboldt	XS532765>533163>532804\$1
635034	CLRND 5	161.0	560001	NODAWAYCO	161.0	1	153	147.1	147.3	3.8%	S1280 to Humboldt	XS533038>533788>533104\$1
635034	CLRND 5	161.0	560001	NODAWAYCO	161.0	1	153	147.1	147.3	3.8%	S1280 to Humboldt	XS652509>652549>\$1
635034	CLRND 5	161.0	560001	NODAWAYCO	161.0	1	153	147	147.3	3.8%	S1280 to Humboldt	XS652573>659206>\$1
635034	CLRND 5	161.0	560001	NODAWAYCO	161.0	1	153	147	147.3	3.8%	S1280 to Humboldt	D-CIRCUIT#12

635034	CLRND 5	161.0	560001	NODAWAYCO	161.0	1	153	147.1	147.3	3.8%	S1280 to Humboldt	LES7501
635034	CLRND 5	161.0	560001	NODAWAYCO	161.0	1	153	147	147.3	3.8%	S1280 to Humboldt	CB975-T4-965
635034	CLRND 5	161.0	560001	NODAWAYCO	161.0	1	153	147	147.3	3.8%	S1399 to Humboldt	XS636636>636672>\$1
635034	CLRND 5	161.0	560001	NODAWAYCO	161.0	1	153	147	147.3	3.8%	S1399 to Humboldt	XS640313>640314>\$1
635034	CLRND 5	161.0	560001	NODAWAYCO	161.0	1	153	147	147.3	3.8%	S1399 to Humboldt	XS300041>344154>\$1
635034	CLRND 5	161.0	560001	NODAWAYCO	161.0	1	153	147	147.3	3.8%	S1399 to Humboldt	XS652505>652229>652227\$1
635034	CLRND 5	161.0	560001	NODAWAYCO	161.0	1	153	147	147.3	3.8%	S1399 to Humboldt	XS652502>652254>652255\$1
635034	CLRND 5	161.0	560001	NODAWAYCO	161.0	1	153	147	147.3	3.8%	S1399 to Humboldt	1211-50-LS
635034	CLRND 5	161.0	560001	NODAWAYCO	161.0	1	153	147	147.3	3.8%	S1399 to Humboldt	CB1251-97&FC
635034	CLRND 5	161.0	560001	NODAWAYCO	161.0	1	153	147	147.3	3.8%	S1399 to Humboldt	XS542965>542977>\$1
635034	CLRND 5	161.0	560001	NODAWAYCO	161.0	1	153	147	147.3	3.8%	S1399 to Humboldt	XS631007>631030>\$1
635034	CLRND 5	161.0	560001	NODAWAYCO	161.0	1	153	147	147.3	3.8%	S1399 to Humboldt	XS631002>629108>\$1
635034	CLRND 5	161.0	560001	NODAWAYCO	161.0	1	153	147.1	147.3	3.8%	S975 (Humboldt) T4 161-69	XS640234>646280>\$1
635034	CLRND 5	161.0	560001	NODAWAYCO	161.0	1	153	147.1	147.3	3.8%	S975 (Humboldt) T4 161-69	XS300036>344923>\$1
635034	CLRND 5	161.0	560001	NODAWAYCO	161.0	1	153	147	147.3	3.8%	S975 (Humboldt) T4 161-69	XS647401>647977>\$1
635034	CLRND 5	161.0	560001	NODAWAYCO	161.0	1	153	147.1	147.3	3.8%	S975 (Humboldt) T4 161-69	CB1399-BUS
635034	CLRND 5	161.0	560001	NODAWAYCO	161.0	1	153	146.9	147.2	4.8%	S1399 to Humboldt	XS636000>636001>636002\$1
635034	CLRND 5	161.0	560001	NODAWAYCO	161.0	1	153	146.9	147.2	4.8%	S1399 to Humboldt	XS635680>635690>\$1
635034	CLRND 5	161.0	560001	NODAWAYCO	161.0	1	153	146.9	147.2	4.8%	S1399 to Humboldt	XS636000>636010>\$1
635034	CLRND 5	161.0	560001	NODAWAYCO	161.0	1	153	146.9	147.2	4.8%	S1399 to Humboldt	XS631110>631115>\$2
635034	CLRND 5	161.0	560001	NODAWAYCO	161.0	1	153	146.9	147.2	4.8%	S1399 to Humboldt	XS640308>640309>\$1
635034	CLRND 5	161.0	560001	NODAWAYCO	161.0	1	153	146.9	147.2	4.8%	S1399 to Humboldt	XS640323>640324>\$1
635034	CLRND 5	161.0	560001	NODAWAYCO	161.0	1	153	146.9	147.2	4.8%	S1399 to Humboldt	XS640284>640308>\$1
635034	CLRND 5	161.0	560001	NODAWAYCO	161.0	1	153	146.9	147.2	4.8%	S1399 to Humboldt	XS646281>646287>\$1
635034	CLRND 5	161.0	560001	NODAWAYCO	161.0	1	153	146.9	147.2	4.8%	S1399 to Humboldt	XS300030>338187>\$1
635034	CLRND 5	161.0	560001	NODAWAYCO	161.0	1	153	146.9	147.2	4.8%	S1399 to Humboldt	S1210 AUTOV3

635034	CLRNDA 5	161.0	560001	NODAWAYCO	161.0	1	153	146.9	147.2	4.8%	S1399 to Humboldt	XS652551>652298>\$1
635034	CLRNDA 5	161.0	560001	NODAWAYCO	161.0	1	153	146.9	147.2	4.8%	S1399 to Humboldt	XS652534>652290>\$1
635034	CLRNDA 5	161.0	560001	NODAWAYCO	161.0	1	153	146.9	147.2	4.8%	S1399 to Humboldt	XS659185>659243>\$1
635034	CLRNDA 5	161.0	560001	NODAWAYCO	161.0	1	153	146.9	147.2	4.8%	S1399 to Humboldt	D-CIRCUIT#16
635034	CLRNDA 5	161.0	560001	NODAWAYCO	161.0	1	153	146.9	147.2	4.8%	S1399 to Humboldt	LES0007
635034	CLRNDA 5	161.0	560001	NODAWAYCO	161.0	1	153	146.9	147.2	4.8%	S1399 to Humboldt	CB906S69B994
635034	CLRNDA 5	161.0	560001	NODAWAYCO	161.0	1	153	146.9	147.2	4.8%	S1399 to Humboldt	D-CIRCUIT #5
635034	CLRNDA 5	161.0	560001	NODAWAYCO	161.0	1	153	146.9	147.2	4.8%	S1399 to Humboldt	CB924-BUS
635034	CLRNDA 5	161.0	560001	NODAWAYCO	161.0	1	153	146.9	147.2	4.8%	S1399 to Humboldt	LES7005
635034	CLRNDA 5	161.0	560001	NODAWAYCO	161.0	1	153	146.9	147.2	4.8%	S1399 to Humboldt	LES6704
635034	CLRNDA 5	161.0	560001	NODAWAYCO	161.0	1	153	146.8	147.2	4.8%	S1399 to Humboldt	BKR-MOR-3306
635034	CLRNDA 5	161.0	560001	NODAWAYCO	161.0	1	153	146.9	147.2	4.8%	S1399 to Humboldt	LES0012A
635034	CLRNDA 5	161.0	560001	NODAWAYCO	161.0	1	153	146.9	147.2	4.8%	S1399 to Humboldt	XS541218>541157>\$1
635034	CLRNDA 5	161.0	560001	NODAWAYCO	161.0	1	153	146.9	147.2	4.8%	S1399 to Humboldt	XS541218>541158>\$1
635034	CLRNDA 5	161.0	560001	NODAWAYCO	161.0	1	153	146.9	147.2	4.8%	S1399 to Humboldt	XS541218>541155>\$1
635034	CLRNDA 5	161.0	560001	NODAWAYCO	161.0	1	153	146.9	147.2	4.8%	S1399 to Humboldt	XS541218>541156>\$1
635034	CLRNDA 5	161.0	560001	NODAWAYCO	161.0	1	153	146.9	147.2	4.8%	S1399 to Humboldt	XS631089>629088>\$1
635034	CLRNDA 5	161.0	560001	NODAWAYCO	161.0	1	153	146.9	147.2	4.8%	S1399 to Humboldt	XS631078>630395>\$1
635034	CLRNDA 5	161.0	560001	NODAWAYCO	161.0	1	153	146.9	147.2	4.8%	S1399 to Humboldt	XS631082>629133>\$1
635034	CLRNDA 5	161.0	560001	NODAWAYCO	161.0	1	153	146.8	147.2	4.8%	S1399 to Humboldt	XS631072>629113>\$1
635034	CLRNDA 5	161.0	560001	NODAWAYCO	161.0	1	153	146.9	147.2	3.8%	S1280 to Humboldt	XS635201>635202>\$1
635034	CLRNDA 5	161.0	560001	NODAWAYCO	161.0	1	153	147	147.2	3.8%	S1280 to Humboldt	XS631115>631118>\$1
635034	CLRNDA 5	161.0	560001	NODAWAYCO	161.0	1	153	147	147.2	3.8%	S1280 to Humboldt	XS631118>630044>\$1
635034	CLRNDA 5	161.0	560001	NODAWAYCO	161.0	1	153	147	147.2	3.8%	S1280 to Humboldt	XS650275>650002>\$1
635034	CLRNDA 5	161.0	560001	NODAWAYCO	161.0	1	153	147	147.2	3.8%	S1280 to Humboldt	XS647401>647977>\$1
635034	CLRNDA 5	161.0	560001	NODAWAYCO	161.0	1	153	147	147.2	3.8%	S1280 to Humboldt	CB963BUS1263
635034	CLRNDA 5	161.0	560001	NODAWAYCO	161.0	1	153	147	147.2	3.8%	S1280 to Humboldt	CB963-BUSAUB

635034	CLRND 5	161.0	560001	NODAWAYCO	161.0	1	153	147	147.2	3.8%	S1280 to Humboldt	LES4203
635034	CLRND 5	161.0	560001	NODAWAYCO	161.0	1	153	147	147.2	3.8%	S1280 to Humboldt	XS560332>560333>\$1
635034	CLRND 5	161.0	560001	NODAWAYCO	161.0	1	153	147	147.2	3.8%	S1280 to Humboldt	XS560333>560334>\$1
635034	CLRND 5	161.0	560001	NODAWAYCO	161.0	1	153	146.9	147.2	3.8%	S1399 to Humboldt	XS532913>532920>\$1
635034	CLRND 5	161.0	560001	NODAWAYCO	161.0	1	153	146.8	147.2	3.8%	S1399 to Humboldt	906515-25-94
635034	CLRND 5	161.0	560001	NODAWAYCO	161.0	1	153	146.8	147.2	3.8%	S1399 to Humboldt	CB994-BUS065
635034	CLRND 5	161.0	560001	NODAWAYCO	161.0	1	153	147	147.2	3.8%	S975 (Humboldt) T4 161-69	XS631142>636420>\$1
635034	CLRND 5	161.0	560001	NODAWAYCO	161.0	1	153	147	147.2	3.8%	S1280 to Humboldt	XS635640>635641>\$1
635034	CLRND 5	161.0	560001	NODAWAYCO	161.0	1	153	146.9	147.2	3.8%	S1280 to Humboldt	XS635003>635004>\$1
635034	CLRND 5	161.0	560001	NODAWAYCO	161.0	1	153	146.9	147.2	3.8%	S1280 to Humboldt	XS636400>636420>\$1
635034	CLRND 5	161.0	560001	NODAWAYCO	161.0	1	153	147	147.2	3.8%	S1280 to Humboldt	XS650242>640278>\$1
635034	CLRND 5	161.0	560001	NODAWAYCO	161.0	1	153	146.9	147.2	3.8%	S1280 to Humboldt	XS645459>646209>648259\$1
635034	CLRND 5	161.0	560001	NODAWAYCO	161.0	1	153	147	147.2	3.8%	S1280 to Humboldt	XS532871>539679>\$1
635034	CLRND 5	161.0	560001	NODAWAYCO	161.0	1	153	146.9	147.2	3.8%	S1280 to Humboldt	XS652466>659284>\$1
635034	CLRND 5	161.0	560001	NODAWAYCO	161.0	1	153	147	147.2	3.8%	S1280 to Humboldt	XS652511>652577>\$1
635034	CLRND 5	161.0	560001	NODAWAYCO	161.0	1	153	147	147.2	3.8%	S1280 to Humboldt	XS652511>652575>\$1
635034	CLRND 5	161.0	560001	NODAWAYCO	161.0	1	153	147	147.2	3.8%	S1280 to Humboldt	XS652511>652576>\$1
635034	CLRND 5	161.0	560001	NODAWAYCO	161.0	1	153	147	147.2	3.8%	S1280 to Humboldt	CB1209-T1&T3
635034	CLRND 5	161.0	560001	NODAWAYCO	161.0	1	153	146.9	147.2	3.8%	S1280 to Humboldt	CB963-BUS977
635034	CLRND 5	161.0	560001	NODAWAYCO	161.0	1	153	147	147.2	3.8%	S1280 to Humboldt	BKR-HLD-3006
635034	CLRND 5	161.0	560001	NODAWAYCO	161.0	1	153	147	147.2	3.8%	S1280 to Humboldt	CB1255-21&T1
635034	CLRND 5	161.0	560001	NODAWAYCO	161.0	1	153	147	147.2	3.8%	S1280 to Humboldt	XS541255>541355>\$1
635034	CLRND 5	161.0	560001	NODAWAYCO	161.0	1	153	146.9	147.2	3.8%	S1280 to Humboldt	XS541314>505502>\$1
635034	CLRND 5	161.0	560001	NODAWAYCO	161.0	1	153	147	147.2	3.8%	S1399 to Humboldt	XS646399>560610>\$1
635034	CLRND 5	161.0	560001	NODAWAYCO	161.0	1	153	147	147.2	3.8%	S1399 to Humboldt	XS646399>648500>648501\$1
635034	CLRND 5	161.0	560001	NODAWAYCO	161.0	1	153	146.9	147.2	3.8%	S1399 to Humboldt	CB907-BUS
635034	CLRND 5	161.0	560001	NODAWAYCO	161.0	1	153	146.9	147.2	3.8%	S1399 to Humboldt	1281LINBUS

635034	CLRND 5	161.0	560001	NODAWAYCO	161.0	1	153	146.9	147.2	3.8%	S1399 to Humboldt	CB914-BUS
635034	CLRND 5	161.0	560001	NODAWAYCO	161.0	1	153	147	147.2	3.8%	S1399 to Humboldt	CB1399-BUS
635034	CLRND 5	161.0	560001	NODAWAYCO	161.0	1	153	146.9	147.2	3.8%	S1399 to Humboldt	CB1281-BUS
635034	CLRND 5	161.0	560001	NODAWAYCO	161.0	1	153	146.9	147.2	3.8%	S1399 to Humboldt	XS631074>629110>\$1
635034	CLRND 5	161.0	560001	NODAWAYCO	161.0	1	153	147	147.2	3.8%	S975 (Humboldt) T4 161-69	XS652607>659295>\$1
635034	CLRND 5	161.0	560001	NODAWAYCO	161.0	1	153	147	147.2	3.8%	S975 (Humboldt) T4 161-69	XS635202>635300>\$1
635034	CLRND 5	161.0	560001	NODAWAYCO	161.0	1	153	147	147.2	3.8%	S975 (Humboldt) T4 161-69	CB1209-50&T3
635034	CLRND 5	161.0	560001	NODAWAYCO	161.0	1	153	146.8	147.1	4.8%	S1399 to Humboldt	XS640149>640150>\$1
635034	CLRND 5	161.0	560001	NODAWAYCO	161.0	1	153	146.8	147.1	4.8%	S1399 to Humboldt	XS640163>640164>\$1
635034	CLRND 5	161.0	560001	NODAWAYCO	161.0	1	153	146.7	147.1	4.8%	S1399 to Humboldt	XS640277>650189>\$1
635034	CLRND 5	161.0	560001	NODAWAYCO	161.0	1	153	146.8	147.1	4.8%	S1399 to Humboldt	S1217 AUTOV3
635034	CLRND 5	161.0	560001	NODAWAYCO	161.0	1	153	146.8	147.1	4.8%	S1399 to Humboldt	MC1211-1250
635034	CLRND 5	161.0	560001	NODAWAYCO	161.0	1	153	146.8	147.1	4.8%	S1399 to Humboldt	XS300046>300007>\$1
635034	CLRND 5	161.0	560001	NODAWAYCO	161.0	1	153	146.8	147.1	4.8%	S1399 to Humboldt	MC1211-20-LS
635034	CLRND 5	161.0	560001	NODAWAYCO	161.0	1	153	146.8	147.1	4.8%	S1399 to Humboldt	XS533248>532661>\$1
635034	CLRND 5	161.0	560001	NODAWAYCO	161.0	1	153	146.8	147.1	4.8%	S1399 to Humboldt	LES1504A
635034	CLRND 5	161.0	560001	NODAWAYCO	161.0	1	153	146.8	147.1	4.8%	S1399 to Humboldt	D-CIR #17A
635034	CLRND 5	161.0	560001	NODAWAYCO	161.0	1	153	146.8	147.1	4.8%	S1399 to Humboldt	CB916-BUS
635034	CLRND 5	161.0	560001	NODAWAYCO	161.0	1	153	146.8	147.1	4.8%	S1399 to Humboldt	LES3303
635034	CLRND 5	161.0	560001	NODAWAYCO	161.0	1	153	146.8	147.1	4.8%	S1399 to Humboldt	CB902BUS&937
635034	CLRND 5	161.0	560001	NODAWAYCO	161.0	1	153	146.8	147.1	4.8%	S1399 to Humboldt	CB904BUS&985
635034	CLRND 5	161.0	560001	NODAWAYCO	161.0	1	153	146.8	147.1	4.8%	S1399 to Humboldt	XS541221>541350>\$1
635034	CLRND 5	161.0	560001	NODAWAYCO	161.0	1	153	146.8	147.1	3.8%	S1280 to Humboldt	XS635041>635042>\$1
635034	CLRND 5	161.0	560001	NODAWAYCO	161.0	1	153	146.8	147.1	3.8%	S1280 to Humboldt	XS635310>635311>\$1
635034	CLRND 5	161.0	560001	NODAWAYCO	161.0	1	153	146.8	147.1	3.8%	S1280 to Humboldt	XS635041>635043>\$2
635034	CLRND 5	161.0	560001	NODAWAYCO	161.0	1	153	146.8	147.1	3.8%	S1280 to Humboldt	XS635633>635636>\$1
635034	CLRND 5	161.0	560001	NODAWAYCO	161.0	1	153	146.8	147.1	3.8%	S1280 to Humboldt	XS635330>635331>\$1

635034	CLRND 5	161.0	560001	NODAWAYCO	161.0	1	153	146.8	147.1	3.8%	S1280 to Humboldt	XS635633>635634>\$1
635034	CLRND 5	161.0	560001	NODAWAYCO	161.0	1	153	146.8	147.1	3.8%	S1280 to Humboldt	XS635310>635320>\$1
635034	CLRND 5	161.0	560001	NODAWAYCO	161.0	1	153	146.9	147.1	3.8%	S1280 to Humboldt	XS631112>344001>\$1
635034	CLRND 5	161.0	560001	NODAWAYCO	161.0	1	153	146.9	147.1	3.8%	S1280 to Humboldt	XS631122>631176>\$1
635034	CLRND 5	161.0	560001	NODAWAYCO	161.0	1	153	146.9	147.1	3.8%	S1280 to Humboldt	XS640169>640208>\$1
635034	CLRND 5	161.0	560001	NODAWAYCO	161.0	1	153	146.9	147.1	3.8%	S1280 to Humboldt	XS640088>640278>\$1
635034	CLRND 5	161.0	560001	NODAWAYCO	161.0	1	153	146.8	147.1	3.8%	S1280 to Humboldt	S3454T1 AUTO
635034	CLRND 5	161.0	560001	NODAWAYCO	161.0	1	153	146.9	147.1	3.8%	S1280 to Humboldt	MC1221-31-55
635034	CLRND 5	161.0	560001	NODAWAYCO	161.0	1	153	146.8	147.1	3.8%	S1280 to Humboldt	XS532773>532873>532813\$1
635034	CLRND 5	161.0	560001	NODAWAYCO	161.0	1	153	146.8	147.1	3.8%	S1280 to Humboldt	XS532863>532874>\$1
635034	CLRND 5	161.0	560001	NODAWAYCO	161.0	1	153	146.9	147.1	3.8%	S1280 to Humboldt	XS652537>601007>\$1
635034	CLRND 5	161.0	560001	NODAWAYCO	161.0	1	153	146.8	147.1	3.8%	S1280 to Humboldt	CB1221-55&T9
635034	CLRND 5	161.0	560001	NODAWAYCO	161.0	1	153	146.9	147.1	3.8%	S1280 to Humboldt	CB1206CBSC45
635034	CLRND 5	161.0	560001	NODAWAYCO	161.0	1	153	146.8	147.1	3.8%	S1280 to Humboldt	CB3456-58&CB
635034	CLRND 5	161.0	560001	NODAWAYCO	161.0	1	153	146.8	147.1	3.8%	S1280 to Humboldt	FRE7_GEN
635034	CLRND 5	161.0	560001	NODAWAYCO	161.0	1	153	146.8	147.1	3.8%	S1280 to Humboldt	CB1254-BUS
635034	CLRND 5	161.0	560001	NODAWAYCO	161.0	1	153	146.9	147.1	3.8%	S1280 to Humboldt	XS541314>300034>\$1
635034	CLRND 5	161.0	560001	NODAWAYCO	161.0	1	153	146.9	147.1	3.8%	S1280 to Humboldt	XS542972>541201>\$1
635034	CLRND 5	161.0	560001	NODAWAYCO	161.0	1	153	146.8	147.1	3.8%	S1280 to Humboldt	XS631053>629073>\$1
635034	CLRND 5	161.0	560001	NODAWAYCO	161.0	1	153	146.8	147.1	3.8%	S1399 to Humboldt	XS652397>659259>\$1
635034	CLRND 5	161.0	560001	NODAWAYCO	161.0	1	153	146.8	147.1	3.8%	S1399 to Humboldt	XS300103>300006>\$1
635034	CLRND 5	161.0	560001	NODAWAYCO	161.0	1	153	146.8	147.1	3.8%	S1399 to Humboldt	CB3451-RN&T4
635034	CLRND 5	161.0	560001	NODAWAYCO	161.0	1	153	146.8	147.1	3.8%	S1399 to Humboldt	CB900-BUS
635034	CLRND 5	161.0	560001	NODAWAYCO	161.0	1	153	146.8	147.1	3.8%	S975 (Humboldt) T4 161-69	XS631171>631172>\$1
635034	CLRND 5	161.0	560001	NODAWAYCO	161.0	1	153	146.9	147.1	3.8%	S975 (Humboldt) T4 161-69	XS635310>635330>\$1
635034	CLRND 5	161.0	560001	NODAWAYCO	161.0	1	153	146.8	147.1	3.8%	S975 (Humboldt) T4 161-69	XS631171>631173>\$1

635034	CLRND 5 161.0	560001	NODAWAYCO 161.0	1	153	146.9	147.1	3.8%	S975 (Humboldt) T4 161-69	XS640267>640287>\$1
635034	CLRND 5 161.0	560001	NODAWAYCO 161.0	1	153	146.9	147.1	3.8%	S975 (Humboldt) T4 161-69	XS640325>640326>640327>\$1
635034	CLRND 5 161.0	560001	NODAWAYCO 161.0	1	153	146.9	147.1	3.8%	S975 (Humboldt) T4 161-69	XS532766>532770>\$1
635034	CLRND 5 161.0	560001	NODAWAYCO 161.0	1	153	146.8	147.1	3.8%	S975 (Humboldt) T4 161-69	XS300110>300320>\$1
635034	CLRND 5 161.0	560001	NODAWAYCO 161.0	1	153	146.8	147.1	3.8%	S975 (Humboldt) T4 161-69	XS645455>646255>648255\$1
635034	CLRND 5 161.0	560001	NODAWAYCO 161.0	1	153	146.9	147.1	3.8%	S975 (Humboldt) T4 161-69	XS631087>631088>\$1
635034	CLRND 5 161.0	560001	NODAWAYCO 161.0	1	153	146.8	147.1	3.8%	S975 (Humboldt) T4 161-69	XS541228>541229>\$1
635034	CLRND 5 161.0	560001	NODAWAYCO 161.0	1	153	146.9	147.1	3.8%	S975 (Humboldt) T4 161-69	XS541207>541240>\$1
635034	CLRND 5 161.0	560001	NODAWAYCO 161.0	1	153	146.8	147.1	3.8%	S975 (Humboldt) T4 161-69	CB1221-31&T9
635034	CLRND 5 161.0	560001	NODAWAYCO 161.0	1	153	146.7	147	4.8%	S1399 to Humboldt	XS635200>640226>\$1
635034	CLRND 5 161.0	560001	NODAWAYCO 161.0	1	153	146.7	147	4.8%	S1399 to Humboldt	XS635200>645451>\$1
635034	CLRND 5 161.0	560001	NODAWAYCO 161.0	1	153	146.7	147	4.8%	S1399 to Humboldt	XS635632>635633>\$1
635034	CLRND 5 161.0	560001	NODAWAYCO 161.0	1	153	146.7	147	4.8%	S1399 to Humboldt	XS300069>300021>\$22
635034	CLRND 5 161.0	560001	NODAWAYCO 161.0	1	153	146.7	147	4.8%	S1399 to Humboldt	XS300069>300031>\$10
635034	CLRND 5 161.0	560001	NODAWAYCO 161.0	1	153	146.7	147	4.8%	S1399 to Humboldt	XS300069>300020>\$21
635034	CLRND 5 161.0	560001	NODAWAYCO 161.0	1	153	146.7	147	4.8%	S1399 to Humboldt	XS300069>300032>\$11
635034	CLRND 5 161.0	560001	NODAWAYCO 161.0	1	153	146.7	147	4.8%	S1399 to Humboldt	XS300051>300054>\$1
635034	CLRND 5 161.0	560001	NODAWAYCO 161.0	1	153	146.6	147	4.8%	S1399 to Humboldt	XS531451>531429>531452\$1
635034	CLRND 5 161.0	560001	NODAWAYCO 161.0	1	153	146.7	147	4.8%	S1399 to Humboldt	XS533045>532734>\$1
635034	CLRND 5 161.0	560001	NODAWAYCO 161.0	1	153	146.7	147	4.8%	S1399 to Humboldt	XS533180>532671>\$1
635034	CLRND 5 161.0	560001	NODAWAYCO 161.0	1	153	146.6	147	4.8%	S1399 to Humboldt	CB1345-BUS
635034	CLRND 5 161.0	560001	NODAWAYCO 161.0	1	153	146.6	147	4.8%	S1399 to Humboldt	CB928-BUS
635034	CLRND 5 161.0	560001	NODAWAYCO 161.0	1	153	146.7	147	4.8%	S1399 to Humboldt	CB1220-BUS
635034	CLRND 5 161.0	560001	NODAWAYCO 161.0	1	153	146.7	147	4.8%	S1399 to Humboldt	CB3455-56&T1
635034	CLRND 5 161.0	560001	NODAWAYCO 161.0	1	153	146.7	147	4.8%	S1399 to Humboldt	CBFREM-F
635034	CLRND 5 161.0	560001	NODAWAYCO 161.0	1	153	146.7	147	4.8%	S1399 to Humboldt	XS560332>640208>\$1

635034	CLRND 5	161.0	560001	NODAWAYCO	161.0	1	153	146.7	147	3.8%	S1280 to Humboldt	XS635350>635353>\$2
635034	CLRND 5	161.0	560001	NODAWAYCO	161.0	1	153	146.8	147	3.8%	S1280 to Humboldt	XS636029>636028>\$1
635034	CLRND 5	161.0	560001	NODAWAYCO	161.0	1	153	146.7	147	3.8%	S1280 to Humboldt	XS635320>635319>\$1
635034	CLRND 5	161.0	560001	NODAWAYCO	161.0	1	153	146.7	147	3.8%	S1280 to Humboldt	XS635320>635318>\$1
635034	CLRND 5	161.0	560001	NODAWAYCO	161.0	1	153	146.8	147	3.8%	S1280 to Humboldt	XS635650>635651>\$1
635034	CLRND 5	161.0	560001	NODAWAYCO	161.0	1	153	146.7	147	3.8%	S1280 to Humboldt	XS635650>635690>\$1
635034	CLRND 5	161.0	560001	NODAWAYCO	161.0	1	153	146.7	147	3.8%	S1280 to Humboldt	XS636235>636237>\$1
635034	CLRND 5	161.0	560001	NODAWAYCO	161.0	1	153	146.7	147	3.8%	S1280 to Humboldt	XS636400>636630>\$1
635034	CLRND 5	161.0	560001	NODAWAYCO	161.0	1	153	146.7	147	3.8%	S1280 to Humboldt	XS636630>636640>\$1
635034	CLRND 5	161.0	560001	NODAWAYCO	161.0	1	153	146.8	147	3.8%	S1280 to Humboldt	XS640404>652573>\$1
635034	CLRND 5	161.0	560001	NODAWAYCO	161.0	1	153	146.8	147	3.8%	S1280 to Humboldt	XS650275>650001>\$1
635034	CLRND 5	161.0	560001	NODAWAYCO	161.0	1	153	146.7	147	3.8%	S1280 to Humboldt	XS645455>646255>648255\$1
635034	CLRND 5	161.0	560001	NODAWAYCO	161.0	1	153	146.7	147	3.8%	S1280 to Humboldt	XS645454>646254>648254\$1
635034	CLRND 5	161.0	560001	NODAWAYCO	161.0	1	153	146.8	147	3.8%	S1280 to Humboldt	S1221 AUTOV2
635034	CLRND 5	161.0	560001	NODAWAYCO	161.0	1	153	146.8	147	3.8%	S1280 to Humboldt	XS532873>532874>\$1
635034	CLRND 5	161.0	560001	NODAWAYCO	161.0	1	153	146.7	147	3.8%	S1280 to Humboldt	XS300320>548808>\$1
635034	CLRND 5	161.0	560001	NODAWAYCO	161.0	1	153	146.8	147	3.8%	S1280 to Humboldt	XS533332>560141>\$1
635034	CLRND 5	161.0	560001	NODAWAYCO	161.0	1	153	146.7	147	3.8%	S1280 to Humboldt	XS928113>928115>\$1
635034	CLRND 5	161.0	560001	NODAWAYCO	161.0	1	153	146.7	147	3.8%	S1280 to Humboldt	FRE6_GEN
635034	CLRND 5	161.0	560001	NODAWAYCO	161.0	1	153	146.7	147	3.8%	S1280 to Humboldt	CB1255-59&T3
635034	CLRND 5	161.0	560001	NODAWAYCO	161.0	1	153	146.7	147	3.8%	S1280 to Humboldt	CB975-T4-993
635034	CLRND 5	161.0	560001	NODAWAYCO	161.0	1	153	146.8	147	3.8%	S1280 to Humboldt	XS541254>541256>\$1
635034	CLRND 5	161.0	560001	NODAWAYCO	161.0	1	153	146.8	147	3.8%	S1280 to Humboldt	XS543028>543029>\$1
635034	CLRND 5	161.0	560001	NODAWAYCO	161.0	1	153	146.8	147	3.8%	S1280 to Humboldt	XS541240>301342>\$1
635034	CLRND 5	161.0	560001	NODAWAYCO	161.0	1	153	146.8	147	3.8%	S1280 to Humboldt	XS631086>631087>\$1
635034	CLRND 5	161.0	560001	NODAWAYCO	161.0	1	153	146.6	147	3.8%	S1399 to Humboldt	XS300069>300024>\$20
635034	CLRND 5	161.0	560001	NODAWAYCO	161.0	1	153	146.6	147	3.8%	S1399 to Humboldt	XS300069>300033>\$12

635034	CLRND 5 161.0	560001	NODAWAYCO 161.0	1	153	146.7	147	3.8%	S1399 to Humboldt	161T37BK1OR2
635034	CLRND 5 161.0	560001	NODAWAYCO 161.0	1	153	146.8	147	3.8%	S975 (Humboldt) T4 161-69	XS652509>652526>\$1
635034	CLRND 5 161.0	560001	NODAWAYCO 161.0	1	153	146.8	147	3.8%	S975 (Humboldt) T4 161-69	XS652523>652578>\$1
635034	CLRND 5 161.0	560001	NODAWAYCO 161.0	1	153	146.8	147	3.8%	S975 (Humboldt) T4 161-69	XS652607>659122>\$1
635034	CLRND 5 161.0	560001	NODAWAYCO 161.0	1	153	146.8	147	3.8%	S975 (Humboldt) T4 161-69	XS646206>646244>\$1
635034	CLRND 5 161.0	560001	NODAWAYCO 161.0	1	153	146.8	147	3.8%	S975 (Humboldt) T4 161-69	XS631048>656201>\$1
635034	CLRND 5 161.0	560001	NODAWAYCO 161.0	1	153	146.8	147	3.8%	S975 (Humboldt) T4 161-69	XS541208>301342>\$1
635034	CLRND 5 161.0	560001	NODAWAYCO 161.0	1	153	146.8	147	3.8%	S975 (Humboldt) T4 161-69	XS533308>533309>\$1
635034	CLRND 5 161.0	560001	NODAWAYCO 161.0	1	153	146.8	147	3.8%	S975 (Humboldt) T4 161-69	XS541235>541250>\$1
635034	CLRND 5 161.0	560001	NODAWAYCO 161.0	1	153	146.6	146.9	4.8%	S1399 to Humboldt	XS635005>635010>\$1
635034	CLRND 5 161.0	560001	NODAWAYCO 161.0	1	153	146.6	146.9	4.8%	S1399 to Humboldt	XS645454>645455>\$1
635034	CLRND 5 161.0	560001	NODAWAYCO 161.0	1	153	146.6	146.9	4.8%	S1399 to Humboldt	NEB121
635034	CLRND 5 161.0	560001	NODAWAYCO 161.0	1	153	146.6	146.9	4.8%	S1399 to Humboldt	XS532797>542981>\$1
635034	CLRND 5 161.0	560001	NODAWAYCO 161.0	1	153	146.5	146.9	4.8%	S1399 to Humboldt	CB1287-BUS
635034	CLRND 5 161.0	560001	NODAWAYCO 161.0	1	153	146.6	146.9	4.8%	S1399 to Humboldt	CB1253-BUS
635034	CLRND 5 161.0	560001	NODAWAYCO 161.0	1	153	146.6	146.9	4.8%	S1399 to Humboldt	CB1216-BUS
635034	CLRND 5 161.0	560001	NODAWAYCO 161.0	1	153	146.5	146.9	4.8%	S1399 to Humboldt	CB1226-37&52
635034	CLRND 5 161.0	560001	NODAWAYCO 161.0	1	153	146.5	146.9	4.8%	S1399 to Humboldt	CBWAG-T2-54
635034	CLRND 5 161.0	560001	NODAWAYCO 161.0	1	153	146.5	146.9	4.8%	S1399 to Humboldt	CBWAG-T1-54
635034	CLRND 5 161.0	560001	NODAWAYCO 161.0	1	153	146.6	146.9	4.8%	S1399 to Humboldt	LES1501
635034	CLRND 5 161.0	560001	NODAWAYCO 161.0	1	153	146.6	146.9	4.8%	S1399 to Humboldt	CB900BUS&979
635034	CLRND 5 161.0	560001	NODAWAYCO 161.0	1	153	146.6	146.9	4.8%	S1399 to Humboldt	XS542976>542963>\$1
635034	CLRND 5 161.0	560001	NODAWAYCO 161.0	1	153	146.6	146.9	4.8%	S1399 to Humboldt	XS542976>542964>\$1
635034	CLRND 5 161.0	560001	NODAWAYCO 161.0	1	153	146.6	146.9	3.8%	S1280 to Humboldt	XS631143>635730>\$1
635034	CLRND 5 161.0	560001	NODAWAYCO 161.0	1	153	146.7	146.9	3.8%	S1280 to Humboldt	XS631115>631143>\$1
635034	CLRND 5 161.0	560001	NODAWAYCO 161.0	1	153	146.7	146.9	3.8%	S1280 to Humboldt	XS631139>631142>\$1

635034	CLRND 5	161.0	560001	NODAWAYCO	161.0	1	153	146.6	146.9	3.8%	S1280 to Humboldt	XS635200>636010>\$1
635034	CLRND 5	161.0	560001	NODAWAYCO	161.0	1	153	146.7	146.9	3.8%	S1280 to Humboldt	XS635001>635002>\$1
635034	CLRND 5	161.0	560001	NODAWAYCO	161.0	1	153	146.7	146.9	3.8%	S1280 to Humboldt	XS631177>615122>\$1
635034	CLRND 5	161.0	560001	NODAWAYCO	161.0	1	153	146.7	146.9	3.8%	S1280 to Humboldt	XS631176>631177>\$1
635034	CLRND 5	161.0	560001	NODAWAYCO	161.0	1	153	146.7	146.9	3.8%	S1280 to Humboldt	XS636030>636037>\$1
635034	CLRND 5	161.0	560001	NODAWAYCO	161.0	1	153	146.7	146.9	3.8%	S1280 to Humboldt	XS631102>631124>\$1
635034	CLRND 5	161.0	560001	NODAWAYCO	161.0	1	153	146.7	146.9	3.8%	S1280 to Humboldt	XS640050>640051>\$1
635034	CLRND 5	161.0	560001	NODAWAYCO	161.0	1	153	146.7	146.9	3.8%	S1280 to Humboldt	XS640169>640218>\$1
635034	CLRND 5	161.0	560001	NODAWAYCO	161.0	1	153	146.7	146.9	3.8%	S1280 to Humboldt	XS640088>640111>\$1
635034	CLRND 5	161.0	560001	NODAWAYCO	161.0	1	153	146.7	146.9	3.8%	S1280 to Humboldt	XS640111>640278>\$1
635034	CLRND 5	161.0	560001	NODAWAYCO	161.0	1	153	146.7	146.9	3.8%	S1280 to Humboldt	XS636610>636615>\$1
635034	CLRND 5	161.0	560001	NODAWAYCO	161.0	1	153	146.7	146.9	3.8%	S1280 to Humboldt	XS640259>640284>\$1
635034	CLRND 5	161.0	560001	NODAWAYCO	161.0	1	153	146.7	146.9	3.8%	S1280 to Humboldt	XS640396>652573>\$1
635034	CLRND 5	161.0	560001	NODAWAYCO	161.0	1	153	146.7	146.9	3.8%	S1280 to Humboldt	XS640396>640397>640399\$1
635034	CLRND 5	161.0	560001	NODAWAYCO	161.0	1	153	146.7	146.9	3.8%	S1280 to Humboldt	XS647417>647421>\$1
635034	CLRND 5	161.0	560001	NODAWAYCO	161.0	1	153	146.7	146.9	3.8%	S1280 to Humboldt	XS647101>647975>\$1
635034	CLRND 5	161.0	560001	NODAWAYCO	161.0	1	153	146.7	146.9	3.8%	S1280 to Humboldt	XS646249>646254>\$1
635034	CLRND 5	161.0	560001	NODAWAYCO	161.0	1	153	146.7	146.9	3.8%	S1280 to Humboldt	TWR-SCH-CC
635034	CLRND 5	161.0	560001	NODAWAYCO	161.0	1	153	146.7	146.9	3.8%	S1280 to Humboldt	XS300071>300108>\$1
635034	CLRND 5	161.0	560001	NODAWAYCO	161.0	1	153	146.7	146.9	3.8%	S1280 to Humboldt	XS300068>300207>\$1
635034	CLRND 5	161.0	560001	NODAWAYCO	161.0	1	153	146.7	146.9	3.8%	S1280 to Humboldt	XS532771>532773>\$1
635034	CLRND 5	161.0	560001	NODAWAYCO	161.0	1	153	146.7	146.9	3.8%	S1280 to Humboldt	XS532861>532865>\$1
635034	CLRND 5	161.0	560001	NODAWAYCO	161.0	1	153	146.7	146.9	3.8%	S1280 to Humboldt	XS533157>533189>\$1
635034	CLRND 5	161.0	560001	NODAWAYCO	161.0	1	153	146.7	146.9	3.8%	S1280 to Humboldt	XS652507>652606>\$1
635034	CLRND 5	161.0	560001	NODAWAYCO	161.0	1	153	146.7	146.9	3.8%	S1280 to Humboldt	CB1231-21&27
635034	CLRND 5	161.0	560001	NODAWAYCO	161.0	1	153	146.7	146.9	3.8%	S1280 to Humboldt	XS541208>301342>\$1
635034	CLRND 5	161.0	560001	NODAWAYCO	161.0	1	153	146.7	146.9	3.8%	S1280 to Humboldt	XS631075>631076>\$1

635034	CLRND 5 161.0	560001	NODAWAYCO 161.0	1	153	146.7	146.9	3.8%	S1280 to Humboldt	XS631076>345827>\$1
635034	CLRND 5 161.0	560001	NODAWAYCO 161.0	1	153	146.7	146.9	3.8%	S1280 to Humboldt	XS631050>636200>\$1
635034	CLRND 5 161.0	560001	NODAWAYCO 161.0	1	153	146.7	146.9	3.8%	S1280 to Humboldt	XS613330>693755>\$1
635034	CLRND 5 161.0	560001	NODAWAYCO 161.0	1	153	146.6	146.9	3.8%	S1280 to Humboldt	XS631070>630009>\$1
635034	CLRND 5 161.0	560001	NODAWAYCO 161.0	1	153	146.6	146.9	3.8%	S1399 to Humboldt	XS533044>533796>532733\$1
635034	CLRND 5 161.0	560001	NODAWAYCO 161.0	1	153	146.7	146.9	3.8%	S975 (Humboldt) T4 161-69	XS640136>640336>\$1
635034	CLRND 5 161.0	560001	NODAWAYCO 161.0	1	153	146.7	146.9	3.8%	S975 (Humboldt) T4 161-69	XS640226>640342>\$1
635034	CLRND 5 161.0	560001	NODAWAYCO 161.0	1	153	146.7	146.9	3.8%	S975 (Humboldt) T4 161-69	TWR-SCH-MN
635034	CLRND 5 161.0	560001	NODAWAYCO 161.0	1	153	146.7	146.9	3.8%	S975 (Humboldt) T4 161-69	LN-CLATONIA
635034	CLRND 5 161.0	560001	NODAWAYCO 161.0	1	153	146.7	146.9	3.8%	S975 (Humboldt) T4 161-69	XS300110>300124>\$1
635034	CLRND 5 161.0	560001	NODAWAYCO 161.0	1	153	146.7	146.9	3.8%	S975 (Humboldt) T4 161-69	XS532770>532863>532809\$1
635034	CLRND 5 161.0	560001	NODAWAYCO 161.0	1	153	146.7	146.9	3.8%	S975 (Humboldt) T4 161-69	XS650114>650214>650314\$1
635034	CLRND 5 161.0	560001	NODAWAYCO 161.0	1	153	146.7	146.9	3.8%	S975 (Humboldt) T4 161-69	XS631035>629147>\$1
635034	CLRND 5 161.0	560001	NODAWAYCO 161.0	1	153	146.7	146.9	3.8%	S975 (Humboldt) T4 161-69	XS631035>631124>\$1
635034	CLRND 5 161.0	560001	NODAWAYCO 161.0	1	153	146.7	146.9	3.8%	S975 (Humboldt) T4 161-69	XS543057>543068>\$1
635034	CLRND 5 161.0	560001	NODAWAYCO 161.0	1	153	146.7	146.9	3.8%	S975 (Humboldt) T4 161-69	XS543057>543058>\$1
635034	CLRND 5 161.0	560001	NODAWAYCO 161.0	1	153	146.7	146.9	3.8%	S975 (Humboldt) T4 161-69	XS542986>542990>\$1
635034	CLRND 5 161.0	560001	NODAWAYCO 161.0	1	153	146.7	146.9	3.8%	S975 (Humboldt) T4 161-69	XS543064>543072>\$1
635034	CLRND 5 161.0	560001	NODAWAYCO 161.0	1	153	146.6	146.9	3.8%	S1280 to Humboldt	XS631154>631151>\$1
635034	CLRND 5 161.0	560001	NODAWAYCO 161.0	1	153	146.6	146.9	3.8%	S1280 to Humboldt	XS635032>635033>\$1
635034	CLRND 5 161.0	560001	NODAWAYCO 161.0	1	153	146.6	146.9	3.8%	S1280 to Humboldt	XS635300>635330>\$1
635034	CLRND 5 161.0	560001	NODAWAYCO 161.0	1	153	146.6	146.9	3.8%	S1280 to Humboldt	XS631112>630033>\$1
635034	CLRND 5 161.0	560001	NODAWAYCO 161.0	1	153	146.6	146.9	3.8%	S1280 to Humboldt	XS631154>631150>\$1
635034	CLRND 5 161.0	560001	NODAWAYCO 161.0	1	153	146.6	146.9	3.8%	S1280 to Humboldt	XS640096>640381>\$1
635034	CLRND 5 161.0	560001	NODAWAYCO 161.0	1	153	146.6	146.9	3.8%	S1280 to Humboldt	XS640093>640286>\$1

635034	CLRND 5	161.0	560001	NODAWAYCO	161.0	1	153	146.6	146.9	3.8%	S1280 to Humboldt	XS636600>636605>\$1
635034	CLRND 5	161.0	560001	NODAWAYCO	161.0	1	153	146.6	146.9	3.8%	S1280 to Humboldt	XS636400>636401>636406\$1
635034	CLRND 5	161.0	560001	NODAWAYCO	161.0	1	153	146.6	146.9	3.8%	S1280 to Humboldt	XS640125>640342>\$1
635034	CLRND 5	161.0	560001	NODAWAYCO	161.0	1	153	146.6	146.9	3.8%	S1280 to Humboldt	XS640267>640381>\$1
635034	CLRND 5	161.0	560001	NODAWAYCO	161.0	1	153	146.6	146.9	3.8%	S1280 to Humboldt	XS646206>646244>\$1
635034	CLRND 5	161.0	560001	NODAWAYCO	161.0	1	153	146.6	146.9	3.8%	S1280 to Humboldt	XS647102>647970>\$1
635034	CLRND 5	161.0	560001	NODAWAYCO	161.0	1	153	146.6	146.9	3.8%	S1280 to Humboldt	XS647102>647974>\$1
635034	CLRND 5	161.0	560001	NODAWAYCO	161.0	1	153	146.6	146.9	3.8%	S1280 to Humboldt	XS646227>646231>\$1
635034	CLRND 5	161.0	560001	NODAWAYCO	161.0	1	153	146.6	146.9	3.8%	S1280 to Humboldt	TWR-SCH-CM
635034	CLRND 5	161.0	560001	NODAWAYCO	161.0	1	153	146.6	146.9	3.8%	S1280 to Humboldt	XS532796>514715>\$1
635034	CLRND 5	161.0	560001	NODAWAYCO	161.0	1	153	146.6	146.9	3.8%	S1280 to Humboldt	XS533036>539675>\$1
635034	CLRND 5	161.0	560001	NODAWAYCO	161.0	1	153	146.6	146.9	3.8%	S1280 to Humboldt	XS652513>659122>\$1
635034	CLRND 5	161.0	560001	NODAWAYCO	161.0	1	153	146.6	146.9	3.8%	S1280 to Humboldt	CB974-BUS-EN
635034	CLRND 5	161.0	560001	NODAWAYCO	161.0	1	153	146.6	146.9	3.8%	S1280 to Humboldt	CB3451-59&T3
635034	CLRND 5	161.0	560001	NODAWAYCO	161.0	1	153	146.6	146.9	3.8%	S1280 to Humboldt	LN-CLATONIA
635034	CLRND 5	161.0	560001	NODAWAYCO	161.0	1	153	146.6	146.9	3.8%	S1280 to Humboldt	CB974-BUS
635034	CLRND 5	161.0	560001	NODAWAYCO	161.0	1	153	146.6	146.9	3.8%	S1280 to Humboldt	ENRONTAP
635034	CLRND 5	161.0	560001	NODAWAYCO	161.0	1	153	146.6	146.9	3.8%	S1280 to Humboldt	XS541244>541250>\$1
635034	CLRND 5	161.0	560001	NODAWAYCO	161.0	1	153	146.6	146.9	3.8%	S1280 to Humboldt	XS541235>541250>\$1
635034	CLRND 5	161.0	560001	NODAWAYCO	161.0	1	153	146.6	146.9	3.8%	S1280 to Humboldt	XS542969>543057>\$1
635034	CLRND 5	161.0	560001	NODAWAYCO	161.0	1	153	146.6	146.9	3.8%	S1280 to Humboldt	XS631061>631140>\$1
635034	CLRND 5	161.0	560001	NODAWAYCO	161.0	1	153	146.6	146.9	3.8%	S1280 to Humboldt	XS631048>631049>\$1
635034	CLRND 5	161.0	560001	NODAWAYCO	161.0	1	153	146.6	146.9	3.8%	S1280 to Humboldt	XS543060>344558>\$1
635034	CLRND 5	161.0	560001	NODAWAYCO	161.0	1	153	146.6	146.9	3.8%	S1280 to Humboldt	XS543065>543069>\$1
635034	CLRND 5	161.0	560001	NODAWAYCO	161.0	1	153	146.6	146.9	3.8%	S1280 to Humboldt	XS631041>631124>\$1
635034	CLRND 5	161.0	560001	NODAWAYCO	161.0	1	153	146.6	146.9	3.8%	S1280 to Humboldt	XS631081>631082>\$1
635034	CLRND 5	161.0	560001	NODAWAYCO	161.0	1	153	146.6	146.9	3.8%	S975 (Humboldt) T4 161-69	XS652466>652426>\$1

635034	CLRND 5 161.0	560001	NODAWAYCO 161.0	1	153	146.6	146.9	3.8%	S975 (Humboldt) T4 161-69	XS652509>652516>\$1
635034	CLRND 5 161.0	560001	NODAWAYCO 161.0	1	153	146.6	146.9	3.8%	S975 (Humboldt) T4 161-69	XS652565>652564>652304\$1
635034	CLRND 5 161.0	560001	NODAWAYCO 161.0	1	153	146.6	146.9	3.8%	S975 (Humboldt) T4 161-69	XS652482>659153>\$1
635034	CLRND 5 161.0	560001	NODAWAYCO 161.0	1	153	146.7	146.9	3.8%	S975 (Humboldt) T4 161-69	XS635635>635640>\$1
635034	CLRND 5 161.0	560001	NODAWAYCO 161.0	1	153	146.6	146.9	3.8%	S975 (Humboldt) T4 161-69	XS635665>635701>\$1
635034	CLRND 5 161.0	560001	NODAWAYCO 161.0	1	153	146.6	146.9	3.8%	S975 (Humboldt) T4 161-69	XS640136>640181>\$1
635034	CLRND 5 161.0	560001	NODAWAYCO 161.0	1	153	146.6	146.9	3.8%	S975 (Humboldt) T4 161-69	XS640131>640200>\$1
635034	CLRND 5 161.0	560001	NODAWAYCO 161.0	1	153	146.6	146.9	3.8%	S975 (Humboldt) T4 161-69	XS640272>640413>\$1
635034	CLRND 5 161.0	560001	NODAWAYCO 161.0	1	153	146.6	146.9	3.8%	S975 (Humboldt) T4 161-69	XS640242>640015>\$1
635034	CLRND 5 161.0	560001	NODAWAYCO 161.0	1	153	146.6	146.9	3.8%	S975 (Humboldt) T4 161-69	XS640226>640227>643082\$1
635034	CLRND 5 161.0	560001	NODAWAYCO 161.0	1	153	146.6	146.9	3.8%	S975 (Humboldt) T4 161-69	XS640240>640014>\$1
635034	CLRND 5 161.0	560001	NODAWAYCO 161.0	1	153	146.6	146.9	3.8%	S975 (Humboldt) T4 161-69	XS640255>640016>\$1
635034	CLRND 5 161.0	560001	NODAWAYCO 161.0	1	153	146.7	146.9	3.8%	S975 (Humboldt) T4 161-69	XS640374>652571>\$1
635034	CLRND 5 161.0	560001	NODAWAYCO 161.0	1	153	146.6	146.9	3.8%	S975 (Humboldt) T4 161-69	XS640253>640255>\$1
635034	CLRND 5 161.0	560001	NODAWAYCO 161.0	1	153	146.6	146.9	3.8%	S975 (Humboldt) T4 161-69	XS300103>361261>\$1
635034	CLRND 5 161.0	560001	NODAWAYCO 161.0	1	153	146.6	146.9	3.8%	S975 (Humboldt) T4 161-69	XS532871>533413>532892\$1
635034	CLRND 5 161.0	560001	NODAWAYCO 161.0	1	153	146.6	146.9	3.8%	S975 (Humboldt) T4 161-69	XS646233>646234>\$1
635034	CLRND 5 161.0	560001	NODAWAYCO 161.0	1	153	146.6	146.9	3.8%	S975 (Humboldt) T4 161-69	XS646232>646278>\$1
635034	CLRND 5 161.0	560001	NODAWAYCO 161.0	1	153	146.6	146.9	3.8%	S975 (Humboldt) T4 161-69	XS646253>646256>\$1
635034	CLRND 5 161.0	560001	NODAWAYCO 161.0	1	153	146.6	146.9	3.8%	S975 (Humboldt) T4 161-69	XS646250>646297>\$1
635034	CLRND 5 161.0	560001	NODAWAYCO 161.0	1	153	146.6	146.9	3.8%	S975 (Humboldt) T4 161-69	XS646217>646227>\$1
635034	CLRND 5 161.0	560001	NODAWAYCO 161.0	1	153	146.6	146.9	3.8%	S975 (Humboldt) T4 161-69	XS631034>631092>\$1
635034	CLRND 5 161.0	560001	NODAWAYCO 161.0	1	153	146.6	146.9	3.8%	S975 (Humboldt) T4 161-69	XS631034>631093>\$1
635034	CLRND 5 161.0	560001	NODAWAYCO 161.0	1	153	146.6	146.9	3.8%	S975 (Humboldt) T4 161-69	XS631050>631139>\$1

635034	CLRND 5 161.0	560001	NODAWAYCO 161.0	1	153	146.6	146.9	3.8%	S975 (Humboldt) T4 161-69	XS631093>636400>\$1
635034	CLRND 5 161.0	560001	NODAWAYCO 161.0	1	153	146.7	146.9	3.8%	S975 (Humboldt) T4 161-69	XS631074>656283>\$1
635034	CLRND 5 161.0	560001	NODAWAYCO 161.0	1	153	146.6	146.9	3.8%	S975 (Humboldt) T4 161-69	XS543072>543073>\$1
635034	CLRND 5 161.0	560001	NODAWAYCO 161.0	1	153	146.6	146.9	3.8%	S975 (Humboldt) T4 161-69	CB1206-44&T1
635034	CLRND 5 161.0	560001	NODAWAYCO 161.0	1	153	146.6	146.8	4.8%	S1280 to Humboldt	XS640234>640235>643087\$1
635034	CLRND 5 161.0	560001	NODAWAYCO 161.0	1	153	146.5	146.8	4.8%	S1280 to Humboldt	XS640235>640361>\$1
635034	CLRND 5 161.0	560001	NODAWAYCO 161.0	1	153	146.5	146.8	4.8%	S1399 to Humboldt	XS652397>652398>652396\$1
635034	CLRND 5 161.0	560001	NODAWAYCO 161.0	1	153	146.5	146.8	4.8%	S1399 to Humboldt	MC1211-50-LS
635034	CLRND 5 161.0	560001	NODAWAYCO 161.0	1	153	146.5	146.8	4.8%	S1399 to Humboldt	XS300120>300001>\$1
635034	CLRND 5 161.0	560001	NODAWAYCO 161.0	1	153	146.5	146.8	4.8%	S1399 to Humboldt	CB1209-26&31
635034	CLRND 5 161.0	560001	NODAWAYCO 161.0	1	153	146.5	146.8	4.8%	S1399 to Humboldt	CBRAUN-FC-HO
635034	CLRND 5 161.0	560001	NODAWAYCO 161.0	1	153	146.5	146.8	4.8%	S1399 to Humboldt	1252TARP
635034	CLRND 5 161.0	560001	NODAWAYCO 161.0	1	153	146.5	146.8	4.8%	S1399 to Humboldt	XS542965>542981>\$1
635034	CLRND 5 161.0	560001	NODAWAYCO 161.0	1	153	146.4	146.8	4.8%	S1399 to Humboldt	XS560611>560612>\$1
635034	CLRND 5 161.0	560001	NODAWAYCO 161.0	1	153	146.4	146.8	4.8%	S1399 to Humboldt	XS560610>560611>\$1
635034	CLRND 5 161.0	560001	NODAWAYCO 161.0	1	153	146.5	146.8	3.8%	S1280 to Humboldt	XS631115>631134>\$1
635034	CLRND 5 161.0	560001	NODAWAYCO 161.0	1	153	146.6	146.8	3.8%	S1280 to Humboldt	XS635700>635701>635706\$1
635034	CLRND 5 161.0	560001	NODAWAYCO 161.0	1	153	146.5	146.8	3.8%	S1280 to Humboldt	XS635700>635701>635707\$2
635034	CLRND 5 161.0	560001	NODAWAYCO 161.0	1	153	146.6	146.8	3.8%	S1280 to Humboldt	XS635635>635640>\$1
635034	CLRND 5 161.0	560001	NODAWAYCO 161.0	1	153	146.5	146.8	3.8%	S1280 to Humboldt	XS635605>635606>\$1
635034	CLRND 5 161.0	560001	NODAWAYCO 161.0	1	153	146.5	146.8	3.8%	S1280 to Humboldt	XS635651>635660>\$1
635034	CLRND 5 161.0	560001	NODAWAYCO 161.0	1	153	146.6	146.8	3.8%	S1280 to Humboldt	XS635320>656283>\$1
635034	CLRND 5 161.0	560001	NODAWAYCO 161.0	1	153	146.5	146.8	3.8%	S1280 to Humboldt	XS635300>635301>\$1
635034	CLRND 5 161.0	560001	NODAWAYCO 161.0	1	153	146.6	146.8	3.8%	S1280 to Humboldt	XS631113>635870>\$1
635034	CLRND 5 161.0	560001	NODAWAYCO 161.0	1	153	146.6	146.8	3.8%	S1280 to Humboldt	XS635632>635833>\$1
635034	CLRND 5 161.0	560001	NODAWAYCO 161.0	1	153	146.5	146.8	3.8%	S1280 to Humboldt	XS635003>646211>\$1

635034	CLRNDA 5 161.0	560001	NODAWAYCO 161.0	1	153	146.5	146.8	3.8%	S1280 to Humboldt	XS640098>640267>\$1
635034	CLRNDA 5 161.0	560001	NODAWAYCO 161.0	1	153	146.5	146.8	3.8%	S1280 to Humboldt	XS640093>640094>643026\$1
635034	CLRNDA 5 161.0	560001	NODAWAYCO 161.0	1	153	146.6	146.8	3.8%	S1280 to Humboldt	XS640171>640278>\$1
635034	CLRNDA 5 161.0	560001	NODAWAYCO 161.0	1	153	146.6	146.8	3.8%	S1280 to Humboldt	XS640107>640201>\$1
635034	CLRNDA 5 161.0	560001	NODAWAYCO 161.0	1	153	146.5	146.8	3.8%	S1280 to Humboldt	XS640089>640094>\$1
635034	CLRNDA 5 161.0	560001	NODAWAYCO 161.0	1	153	146.5	146.8	3.8%	S1280 to Humboldt	XS640084>640419>\$1
635034	CLRNDA 5 161.0	560001	NODAWAYCO 161.0	1	153	146.6	146.8	3.8%	S1280 to Humboldt	XS640082>640326>\$1
635034	CLRNDA 5 161.0	560001	NODAWAYCO 161.0	1	153	146.5	146.8	3.8%	S1280 to Humboldt	XS640065>640374>\$1
635034	CLRNDA 5 161.0	560001	NODAWAYCO 161.0	1	153	146.5	146.8	3.8%	S1280 to Humboldt	XS640139>640140>643172\$1
635034	CLRNDA 5 161.0	560001	NODAWAYCO 161.0	1	153	146.5	146.8	3.8%	S1280 to Humboldt	XS640139>640140>640142\$1
635034	CLRNDA 5 161.0	560001	NODAWAYCO 161.0	1	153	146.6	146.8	3.8%	S1280 to Humboldt	XS640109>640334>\$1
635034	CLRNDA 5 161.0	560001	NODAWAYCO 161.0	1	153	146.5	146.8	3.8%	S1280 to Humboldt	XS640444>640433>\$1
635034	CLRNDA 5 161.0	560001	NODAWAYCO 161.0	1	153	146.6	146.8	3.8%	S1280 to Humboldt	XS640183>640374>\$1
635034	CLRNDA 5 161.0	560001	NODAWAYCO 161.0	1	153	146.5	146.8	3.8%	S1280 to Humboldt	XS640287>640018>\$1
635034	CLRNDA 5 161.0	560001	NODAWAYCO 161.0	1	153	146.5	146.8	3.8%	S1280 to Humboldt	XS640201>640353>\$1
635034	CLRNDA 5 161.0	560001	NODAWAYCO 161.0	1	153	146.5	146.8	3.8%	S1280 to Humboldt	XS645451>646251>648351\$1
635034	CLRNDA 5 161.0	560001	NODAWAYCO 161.0	1	153	146.5	146.8	3.8%	S1280 to Humboldt	XS645451>646251>648251\$1
635034	CLRNDA 5 161.0	560001	NODAWAYCO 161.0	1	153	146.6	146.8	3.8%	S1280 to Humboldt	XS646214>647014>648214\$1
635034	CLRNDA 5 161.0	560001	NODAWAYCO 161.0	1	153	146.6	146.8	3.8%	S1280 to Humboldt	XS646233>646255>\$1
635034	CLRNDA 5 161.0	560001	NODAWAYCO 161.0	1	153	146.6	146.8	3.8%	S1280 to Humboldt	XS650238>650242>\$1
635034	CLRNDA 5 161.0	560001	NODAWAYCO 161.0	1	153	146.5	146.8	3.8%	S1280 to Humboldt	XS650269>650275>\$1
635034	CLRNDA 5 161.0	560001	NODAWAYCO 161.0	1	153	146.5	146.8	3.8%	S1280 to Humboldt	XS647101>647963>\$1
635034	CLRNDA 5 161.0	560001	NODAWAYCO 161.0	1	153	146.6	146.8	3.8%	S1280 to Humboldt	XS647402>647970>\$1
635034	CLRNDA 5 161.0	560001	NODAWAYCO 161.0	1	153	146.5	146.8	3.8%	S1280 to Humboldt	XS647402>647971>\$1
635034	CLRNDA 5 161.0	560001	NODAWAYCO 161.0	1	153	146.6	146.8	3.8%	S1280 to Humboldt	XS646251>646297>\$1
635034	CLRNDA 5 161.0	560001	NODAWAYCO 161.0	1	153	146.6	146.8	3.8%	S1280 to Humboldt	XS650114>650214>650314\$1
635034	CLRNDA 5 161.0	560001	NODAWAYCO 161.0	1	153	146.5	146.8	3.8%	S1280 to Humboldt	XS646249>646256>\$1

635034	CLRND 5	161.0	560001	NODAWAYCO	161.0	1	153	146.6	146.8	3.8%	S1280 to Humboldt	XS646259>646278>\$1
635034	CLRND 5	161.0	560001	NODAWAYCO	161.0	1	153	146.6	146.8	3.8%	S1280 to Humboldt	XS300090>300523>\$1
635034	CLRND 5	161.0	560001	NODAWAYCO	161.0	1	153	146.5	146.8	3.8%	S1280 to Humboldt	XS300066>300953>\$1
635034	CLRND 5	161.0	560001	NODAWAYCO	161.0	1	153	146.6	146.8	3.8%	S1280 to Humboldt	XS300058>344697>\$1
635034	CLRND 5	161.0	560001	NODAWAYCO	161.0	1	153	146.6	146.8	3.8%	S1280 to Humboldt	XS300099>300523>\$1
635034	CLRND 5	161.0	560001	NODAWAYCO	161.0	1	153	146.6	146.8	3.8%	S1280 to Humboldt	XS300101>505498>\$1
635034	CLRND 5	161.0	560001	NODAWAYCO	161.0	1	153	146.6	146.8	3.8%	S1280 to Humboldt	XS300098>548808>\$1
635034	CLRND 5	161.0	560001	NODAWAYCO	161.0	1	153	146.6	146.8	3.8%	S1280 to Humboldt	TWR-SCH-NH
635034	CLRND 5	161.0	560001	NODAWAYCO	161.0	1	153	146.5	146.8	3.8%	S1280 to Humboldt	MC1214-14-46
635034	CLRND 5	161.0	560001	NODAWAYCO	161.0	1	153	146.5	146.8	3.8%	S1280 to Humboldt	XS300555>300563>\$1
635034	CLRND 5	161.0	560001	NODAWAYCO	161.0	1	153	146.5	146.8	3.8%	S1280 to Humboldt	XS300499>300953>\$1
635034	CLRND 5	161.0	560001	NODAWAYCO	161.0	1	153	146.6	146.8	3.8%	S1280 to Humboldt	XS532772>533268>532816\$1
635034	CLRND 5	161.0	560001	NODAWAYCO	161.0	1	153	146.6	146.8	3.8%	S1280 to Humboldt	XS532772>533268>532811\$1
635034	CLRND 5	161.0	560001	NODAWAYCO	161.0	1	153	146.5	146.8	3.8%	S1280 to Humboldt	XS300499>343001>\$1
635034	CLRND 5	161.0	560001	NODAWAYCO	161.0	1	153	146.6	146.8	3.8%	S1280 to Humboldt	XS533369>533380>\$1
635034	CLRND 5	161.0	560001	NODAWAYCO	161.0	1	153	146.6	146.8	3.8%	S1280 to Humboldt	XS533302>533308>\$1
635034	CLRND 5	161.0	560001	NODAWAYCO	161.0	1	153	146.5	146.8	3.8%	S1280 to Humboldt	XS533220>533226>\$1
635034	CLRND 5	161.0	560001	NODAWAYCO	161.0	1	153	146.5	146.8	3.8%	S1280 to Humboldt	XS533342>533344>\$1
635034	CLRND 5	161.0	560001	NODAWAYCO	161.0	1	153	146.6	146.8	3.8%	S1280 to Humboldt	XS533151>533155>\$1
635034	CLRND 5	161.0	560001	NODAWAYCO	161.0	1	153	146.5	146.8	3.8%	S1280 to Humboldt	XS533249>533250>\$1
635034	CLRND 5	161.0	560001	NODAWAYCO	161.0	1	153	146.5	146.8	3.8%	S1280 to Humboldt	XS533015>533016>\$1
635034	CLRND 5	161.0	560001	NODAWAYCO	161.0	1	153	146.5	146.8	3.8%	S1280 to Humboldt	XS533217>533337>\$1
635034	CLRND 5	161.0	560001	NODAWAYCO	161.0	1	153	146.5	146.8	3.8%	S1280 to Humboldt	XS652523>652606>\$1
635034	CLRND 5	161.0	560001	NODAWAYCO	161.0	1	153	146.5	146.8	3.8%	S1280 to Humboldt	XS652507>652516>\$1
635034	CLRND 5	161.0	560001	NODAWAYCO	161.0	1	153	146.5	146.8	3.8%	S1280 to Humboldt	XS652507>652509>\$1
635034	CLRND 5	161.0	560001	NODAWAYCO	161.0	1	153	146.5	146.8	3.8%	S1280 to Humboldt	XS652570>659197>\$1
635034	CLRND 5	161.0	560001	NODAWAYCO	161.0	1	153	146.5	146.8	3.8%	S1280 to Humboldt	XS652565>652564>652305\$1

635034	CLRND 5	161.0	560001	NODAWAYCO	161.0	1	153	146.6	146.8	3.8%	S1280 to Humboldt	XS652529>659160>\$1
635034	CLRND 5	161.0	560001	NODAWAYCO	161.0	1	153	146.5	146.8	3.8%	S1280 to Humboldt	XS652513>652523>\$1
635034	CLRND 5	161.0	560001	NODAWAYCO	161.0	1	153	146.6	146.8	3.8%	S1280 to Humboldt	CB975-93-AUB
635034	CLRND 5	161.0	560001	NODAWAYCO	161.0	1	153	146.5	146.8	3.8%	S1280 to Humboldt	ELKCITY_GEN
635034	CLRND 5	161.0	560001	NODAWAYCO	161.0	1	153	146.5	146.8	3.8%	S1280 to Humboldt	CB921-BUS
635034	CLRND 5	161.0	560001	NODAWAYCO	161.0	1	153	146.5	146.8	3.8%	S1280 to Humboldt	CB1206-44&T1
635034	CLRND 5	161.0	560001	NODAWAYCO	161.0	1	153	146.5	146.8	3.8%	S1280 to Humboldt	CB975-65-AUB
635034	CLRND 5	161.0	560001	NODAWAYCO	161.0	1	153	146.5	146.8	3.8%	S1280 to Humboldt	CB962-BUS&NH
635034	CLRND 5	161.0	560001	NODAWAYCO	161.0	1	153	146.5	146.8	3.8%	S1280 to Humboldt	LES7502
635034	CLRND 5	161.0	560001	NODAWAYCO	161.0	1	153	146.5	146.8	3.8%	S1280 to Humboldt	CB971-BUS
635034	CLRND 5	161.0	560001	NODAWAYCO	161.0	1	153	146.5	146.8	3.8%	S1280 to Humboldt	CB1298-51&05
635034	CLRND 5	161.0	560001	NODAWAYCO	161.0	1	153	146.6	146.8	3.8%	S1280 to Humboldt	LES3804B
635034	CLRND 5	161.0	560001	NODAWAYCO	161.0	1	153	146.5	146.8	3.8%	S1280 to Humboldt	CB1251-98&T3
635034	CLRND 5	161.0	560001	NODAWAYCO	161.0	1	153	146.5	146.8	3.8%	S1280 to Humboldt	CB1251-41&T4
635034	CLRND 5	161.0	560001	NODAWAYCO	161.0	1	153	146.6	146.8	3.8%	S1280 to Humboldt	CB914A-46-T1
635034	CLRND 5	161.0	560001	NODAWAYCO	161.0	1	153	146.5	146.8	3.8%	S1280 to Humboldt	LN-1176
635034	CLRND 5	161.0	560001	NODAWAYCO	161.0	1	153	146.5	146.8	3.8%	S1280 to Humboldt	LN-1175B
635034	CLRND 5	161.0	560001	NODAWAYCO	161.0	1	153	146.5	146.8	3.8%	S1280 to Humboldt	AUBNOBKR
635034	CLRND 5	161.0	560001	NODAWAYCO	161.0	1	153	146.5	146.8	3.8%	S1280 to Humboldt	XS533435>533527>533446\$1
635034	CLRND 5	161.0	560001	NODAWAYCO	161.0	1	153	146.5	146.8	3.8%	S1280 to Humboldt	XS542986>542996>\$1
635034	CLRND 5	161.0	560001	NODAWAYCO	161.0	1	153	146.5	146.8	3.8%	S1280 to Humboldt	XS533414>533505>533453\$1
635034	CLRND 5	161.0	560001	NODAWAYCO	161.0	1	153	146.6	146.8	3.8%	S1280 to Humboldt	XS542986>542990>\$1
635034	CLRND 5	161.0	560001	NODAWAYCO	161.0	1	153	146.5	146.8	3.8%	S1280 to Humboldt	XS541225>541239>\$1
635034	CLRND 5	161.0	560001	NODAWAYCO	161.0	1	153	146.5	146.8	3.8%	S1280 to Humboldt	XS541205>541226>\$1
635034	CLRND 5	161.0	560001	NODAWAYCO	161.0	1	153	146.6	146.8	3.8%	S1280 to Humboldt	XS543019>541230>\$1
635034	CLRND 5	161.0	560001	NODAWAYCO	161.0	1	153	146.5	146.8	3.8%	S1280 to Humboldt	XS543007>543010>\$1
635034	CLRND 5	161.0	560001	NODAWAYCO	161.0	1	153	146.5	146.8	3.8%	S1280 to Humboldt	XS543006>543009>\$1

635034	CLRNDA 5 161.0	560001	NODAWAYCO 161.0	1	153	146.5	146.8	3.8%	S1280 to Humboldt	XS541255>541256>\$1
635034	CLRNDA 5 161.0	560001	NODAWAYCO 161.0	1	153	146.6	146.8	3.8%	S1280 to Humboldt	XS541232>541236>\$1
635034	CLRNDA 5 161.0	560001	NODAWAYCO 161.0	1	153	146.5	146.8	3.8%	S1280 to Humboldt	XS541228>541234>\$1
635034	CLRNDA 5 161.0	560001	NODAWAYCO 161.0	1	153	146.5	146.8	3.8%	S1280 to Humboldt	XS543051>543075>\$1
635034	CLRNDA 5 161.0	560001	NODAWAYCO 161.0	1	153	146.5	146.8	3.8%	S1280 to Humboldt	XS541226>541227>\$1
635034	CLRNDA 5 161.0	560001	NODAWAYCO 161.0	1	153	146.5	146.8	3.8%	S1280 to Humboldt	XS541217>300071>\$1
635034	CLRNDA 5 161.0	560001	NODAWAYCO 161.0	1	153	146.6	146.8	3.8%	S1280 to Humboldt	XS541204>541349>\$1
635034	CLRNDA 5 161.0	560001	NODAWAYCO 161.0	1	153	146.5	146.8	3.8%	S1280 to Humboldt	XS543074>543076>\$1
635034	CLRNDA 5 161.0	560001	NODAWAYCO 161.0	1	153	146.6	146.8	3.8%	S1280 to Humboldt	XS631051>636210>\$1
635034	CLRNDA 5 161.0	560001	NODAWAYCO 161.0	1	153	146.5	146.8	3.8%	S1280 to Humboldt	XS631066>631068>\$1
635034	CLRNDA 5 161.0	560001	NODAWAYCO 161.0	1	153	146.6	146.8	3.8%	S1280 to Humboldt	XS631067>631068>\$1
635034	CLRNDA 5 161.0	560001	NODAWAYCO 161.0	1	153	146.5	146.8	3.8%	S1280 to Humboldt	XS631063>631141>\$1
635034	CLRNDA 5 161.0	560001	NODAWAYCO 161.0	1	153	146.6	146.8	3.8%	S1280 to Humboldt	XS543067>543068>\$1
635034	CLRNDA 5 161.0	560001	NODAWAYCO 161.0	1	153	146.5	146.8	3.8%	S1399 to Humboldt	XS532768>532741>\$1
635034	CLRNDA 5 161.0	560001	NODAWAYCO 161.0	1	153	146.5	146.8	3.8%	S1399 to Humboldt	XS532768>532740>\$1
635034	CLRNDA 5 161.0	560001	NODAWAYCO 161.0	1	153	146.6	146.8	3.8%	S975 (Humboldt) T4 161-69	XS656087>656089>\$1
635034	CLRNDA 5 161.0	560001	NODAWAYCO 161.0	1	153	146.6	146.8	3.8%	S975 (Humboldt) T4 161-69	XS652526>652536>\$1
635034	CLRNDA 5 161.0	560001	NODAWAYCO 161.0	1	153	146.6	146.8	3.8%	S975 (Humboldt) T4 161-69	XS652609>660004>\$1
635034	CLRNDA 5 161.0	560001	NODAWAYCO 161.0	1	153	146.6	146.8	3.8%	S975 (Humboldt) T4 161-69	XS652514>652614>\$1
635034	CLRNDA 5 161.0	560001	NODAWAYCO 161.0	1	153	146.6	146.8	3.8%	S975 (Humboldt) T4 161-69	XS652512>660001>\$1
635034	CLRNDA 5 161.0	560001	NODAWAYCO 161.0	1	153	146.6	146.8	3.8%	S975 (Humboldt) T4 161-69	XS635603>635604>\$1
635034	CLRNDA 5 161.0	560001	NODAWAYCO 161.0	1	153	146.6	146.8	3.8%	S975 (Humboldt) T4 161-69	XS636220>636221>\$1
635034	CLRNDA 5 161.0	560001	NODAWAYCO 161.0	1	153	146.6	146.8	3.8%	S975 (Humboldt) T4 161-69	XS636210>636211>\$1
635034	CLRNDA 5 161.0	560001	NODAWAYCO 161.0	1	153	146.6	146.8	3.8%	S975 (Humboldt) T4 161-69	XS635200>635201>\$2
635034	CLRNDA 5 161.0	560001	NODAWAYCO 161.0	1	153	146.6	146.8	3.8%	S975 (Humboldt) T4 161-69	XS635200>635201>635205\$1

635034	CLRND 5 161.0	560001	NODAWAYCO 161.0	1	153	146.6	146.8	3.8%	S975 (Humboldt) T4 161-69	XS636601>636656>\$1
635034	CLRND 5 161.0	560001	NODAWAYCO 161.0	1	153	146.6	146.8	3.8%	S975 (Humboldt) T4 161-69	XS636001>636025>\$1
635034	CLRND 5 161.0	560001	NODAWAYCO 161.0	1	153	146.6	146.8	3.8%	S975 (Humboldt) T4 161-69	XS635870>635871>\$1
635034	CLRND 5 161.0	560001	NODAWAYCO 161.0	1	153	146.6	146.8	3.8%	S975 (Humboldt) T4 161-69	XS631166>631170>\$1
635034	CLRND 5 161.0	560001	NODAWAYCO 161.0	1	153	146.6	146.8	3.8%	S975 (Humboldt) T4 161-69	XS636300>636301>\$1
635034	CLRND 5 161.0	560001	NODAWAYCO 161.0	1	153	146.6	146.8	3.8%	S975 (Humboldt) T4 161-69	XS640163>640387>\$1
635034	CLRND 5 161.0	560001	NODAWAYCO 161.0	1	153	146.6	146.8	3.8%	S975 (Humboldt) T4 161-69	XS640134>640136>\$1
635034	CLRND 5 161.0	560001	NODAWAYCO 161.0	1	153	146.6	146.8	3.8%	S975 (Humboldt) T4 161-69	XS636656>636657>\$1
635034	CLRND 5 161.0	560001	NODAWAYCO 161.0	1	153	146.6	146.8	3.8%	S975 (Humboldt) T4 161-69	XS640091>659132>\$1
635034	CLRND 5 161.0	560001	NODAWAYCO 161.0	1	153	146.6	146.8	3.8%	S975 (Humboldt) T4 161-69	XS640107>640345>\$1
635034	CLRND 5 161.0	560001	NODAWAYCO 161.0	1	153	146.6	146.8	3.8%	S975 (Humboldt) T4 161-69	XS640082>640167>\$1
635034	CLRND 5 161.0	560001	NODAWAYCO 161.0	1	153	146.6	146.8	3.8%	S975 (Humboldt) T4 161-69	XS640184>640286>\$1
635034	CLRND 5 161.0	560001	NODAWAYCO 161.0	1	153	146.6	146.8	3.8%	S975 (Humboldt) T4 161-69	XS640109>640147>\$1
635034	CLRND 5 161.0	560001	NODAWAYCO 161.0	1	153	146.6	146.8	3.8%	S975 (Humboldt) T4 161-69	XS640184>640286>\$3
635034	CLRND 5 161.0	560001	NODAWAYCO 161.0	1	153	146.6	146.8	3.8%	S975 (Humboldt) T4 161-69	XS640184>640286>\$2
635034	CLRND 5 161.0	560001	NODAWAYCO 161.0	1	153	146.6	146.8	3.8%	S975 (Humboldt) T4 161-69	XS640105>640178>\$1
635034	CLRND 5 161.0	560001	NODAWAYCO 161.0	1	153	146.6	146.8	3.8%	S975 (Humboldt) T4 161-69	XS640076>640361>\$1
635034	CLRND 5 161.0	560001	NODAWAYCO 161.0	1	153	146.6	146.8	3.8%	S975 (Humboldt) T4 161-69	XS640136>640151>\$1
635034	CLRND 5 161.0	560001	NODAWAYCO 161.0	1	153	146.6	146.8	3.8%	S975 (Humboldt) T4 161-69	XS640068>640086>\$1
635034	CLRND 5 161.0	560001	NODAWAYCO 161.0	1	153	146.6	146.8	3.8%	S975 (Humboldt) T4 161-69	XS640133>640134>640135\$1
635034	CLRND 5 161.0	560001	NODAWAYCO 161.0	1	153	146.6	146.8	3.8%	S975 (Humboldt) T4 161-69	XS640212>652511>\$1
635034	CLRND 5 161.0	560001	NODAWAYCO 161.0	1	153	146.6	146.8	3.8%	S975 (Humboldt) T4 161-69	XS640323>640331>\$1
635034	CLRND 5 161.0	560001	NODAWAYCO 161.0	1	153	146.6	146.8	3.8%	S975 (Humboldt) T4 161-69	XS640235>640361>\$1
635034	CLRND 5 161.0	560001	NODAWAYCO 161.0	1	153	146.6	146.8	3.8%	S975 (Humboldt) T4 161-69	MC1237-45-53

635034	CLRND 5 161.0	560001	NODAWAYCO 161.0	1	153	146.6	146.8	3.8%	S975 (Humboldt) T4 161-69	MC1226-98
635034	CLRND 5 161.0	560001	NODAWAYCO 161.0	1	153	146.6	146.8	3.8%	S975 (Humboldt) T4 161-69	XS300070>300794>\$1
635034	CLRND 5 161.0	560001	NODAWAYCO 161.0	1	153	146.6	146.8	3.8%	S975 (Humboldt) T4 161-69	XS300070>300793>\$1
635034	CLRND 5 161.0	560001	NODAWAYCO 161.0	1	153	146.6	146.8	3.8%	S975 (Humboldt) T4 161-69	LES9005B
635034	CLRND 5 161.0	560001	NODAWAYCO 161.0	1	153	146.6	146.8	3.8%	S975 (Humboldt) T4 161-69	LES9006
635034	CLRND 5 161.0	560001	NODAWAYCO 161.0	1	153	146.6	146.8	3.8%	S975 (Humboldt) T4 161-69	XS300072>300088>\$1
635034	CLRND 5 161.0	560001	NODAWAYCO 161.0	1	153	146.6	146.8	3.8%	S975 (Humboldt) T4 161-69	TRF-KELLY
635034	CLRND 5 161.0	560001	NODAWAYCO 161.0	1	153	146.6	146.8	3.8%	S975 (Humboldt) T4 161-69	XS300129>505480>\$1
635034	CLRND 5 161.0	560001	NODAWAYCO 161.0	1	153	146.6	146.8	3.8%	S975 (Humboldt) T4 161-69	XS300167>300597>\$1
635034	CLRND 5 161.0	560001	NODAWAYCO 161.0	1	153	146.6	146.8	3.8%	S975 (Humboldt) T4 161-69	XS300794>300651>\$1
635034	CLRND 5 161.0	560001	NODAWAYCO 161.0	1	153	146.6	146.8	3.8%	S975 (Humboldt) T4 161-69	XS300563>300566>\$1
635034	CLRND 5 161.0	560001	NODAWAYCO 161.0	1	153	146.6	146.8	3.8%	S975 (Humboldt) T4 161-69	XS300082>300531>\$1
635034	CLRND 5 161.0	560001	NODAWAYCO 161.0	1	153	146.6	146.8	3.8%	S975 (Humboldt) T4 161-69	XS533003>533008>\$1
635034	CLRND 5 161.0	560001	NODAWAYCO 161.0	1	153	146.6	146.8	3.8%	S975 (Humboldt) T4 161-69	XS533008>533021>\$1
635034	CLRND 5 161.0	560001	NODAWAYCO 161.0	1	153	146.6	146.8	3.8%	S975 (Humboldt) T4 161-69	XS532768>532769>\$1
635034	CLRND 5 161.0	560001	NODAWAYCO 161.0	1	153	146.6	146.8	3.8%	S975 (Humboldt) T4 161-69	XS532769>533304>532808\$1
635034	CLRND 5 161.0	560001	NODAWAYCO 161.0	1	153	146.6	146.8	3.8%	S975 (Humboldt) T4 161-69	XS532937>547469>\$1
635034	CLRND 5 161.0	560001	NODAWAYCO 161.0	1	153	146.6	146.8	3.8%	S975 (Humboldt) T4 161-69	XS532793>533021>532824\$1
635034	CLRND 5 161.0	560001	NODAWAYCO 161.0	1	153	146.6	146.8	3.8%	S975 (Humboldt) T4 161-69	XS532856>532863>\$1
635034	CLRND 5 161.0	560001	NODAWAYCO 161.0	1	153	146.6	146.8	3.8%	S975 (Humboldt) T4 161-69	XS647968>647969>\$1
635034	CLRND 5 161.0	560001	NODAWAYCO 161.0	1	153	146.6	146.8	3.8%	S975 (Humboldt) T4 161-69	XS646254>646281>\$1
635034	CLRND 5 161.0	560001	NODAWAYCO 161.0	1	153	146.6	146.8	3.8%	S975 (Humboldt) T4 161-69	XS647014>647846>\$1
635034	CLRND 5 161.0	560001	NODAWAYCO 161.0	1	153	146.6	146.8	3.8%	S975 (Humboldt) T4 161-69	XS647921>647940>\$1
635034	CLRND 5 161.0	560001	NODAWAYCO 161.0	1	153	146.6	146.8	3.8%	S975 (Humboldt) T4 161-69	XS647090>647982>\$1

635034	CLRNDA 5 161.0	560001	NODAWAYCO 161.0	1	153	146.6	146.8	3.8%	S975 (Humboldt) T4 161-69	XS646226>646252>\$1
635034	CLRNDA 5 161.0	560001	NODAWAYCO 161.0	1	153	146.6	146.8	3.8%	S975 (Humboldt) T4 161-69	XS647909>647939>\$1
635034	CLRNDA 5 161.0	560001	NODAWAYCO 161.0	1	153	146.6	146.8	3.8%	S975 (Humboldt) T4 161-69	XS650229>650290>\$1
635034	CLRNDA 5 161.0	560001	NODAWAYCO 161.0	1	153	146.6	146.8	3.8%	S975 (Humboldt) T4 161-69	XS631100>630019>\$1
635034	CLRNDA 5 161.0	560001	NODAWAYCO 161.0	1	153	146.6	146.8	3.8%	S975 (Humboldt) T4 161-69	XS631104>631116>\$1
635034	CLRNDA 5 161.0	560001	NODAWAYCO 161.0	1	153	146.6	146.8	3.8%	S975 (Humboldt) T4 161-69	XS631024>631095>\$1
635034	CLRNDA 5 161.0	560001	NODAWAYCO 161.0	1	153	146.6	146.8	3.8%	S975 (Humboldt) T4 161-69	XS631053>630003>\$1
635034	CLRNDA 5 161.0	560001	NODAWAYCO 161.0	1	153	146.6	146.8	3.8%	S975 (Humboldt) T4 161-69	XS631023>631024>\$1
635034	CLRNDA 5 161.0	560001	NODAWAYCO 161.0	1	153	146.6	146.8	3.8%	S975 (Humboldt) T4 161-69	XS631109>630038>\$1
635034	CLRNDA 5 161.0	560001	NODAWAYCO 161.0	1	153	146.6	146.8	3.8%	S975 (Humboldt) T4 161-69	XS631052>631053>\$1
635034	CLRNDA 5 161.0	560001	NODAWAYCO 161.0	1	153	146.6	146.8	3.8%	S975 (Humboldt) T4 161-69	XS631088>631142>\$1
635034	CLRNDA 5 161.0	560001	NODAWAYCO 161.0	1	153	146.6	146.8	3.8%	S975 (Humboldt) T4 161-69	XS631083>630027>\$1
635034	CLRNDA 5 161.0	560001	NODAWAYCO 161.0	1	153	146.6	146.8	3.8%	S975 (Humboldt) T4 161-69	XS541209>541234>\$1
635034	CLRNDA 5 161.0	560001	NODAWAYCO 161.0	1	153	146.6	146.8	3.8%	S975 (Humboldt) T4 161-69	XS533413>533416>\$1
635034	CLRNDA 5 161.0	560001	NODAWAYCO 161.0	1	153	146.6	146.8	3.8%	S975 (Humboldt) T4 161-69	XS541207>541341>\$1
635034	CLRNDA 5 161.0	560001	NODAWAYCO 161.0	1	153	146.6	146.8	3.8%	S975 (Humboldt) T4 161-69	XS542985>542990>\$1
635034	CLRNDA 5 161.0	560001	NODAWAYCO 161.0	1	153	146.6	146.8	3.8%	S975 (Humboldt) T4 161-69	XS631011>631170>\$1
635034	CLRNDA 5 161.0	560001	NODAWAYCO 161.0	1	153	146.6	146.8	3.8%	S975 (Humboldt) T4 161-69	XS631012>631015>\$1
635034	CLRNDA 5 161.0	560001	NODAWAYCO 161.0	1	153	146.6	146.8	3.8%	S975 (Humboldt) T4 161-69	XS613330>630189>\$1
635034	CLRNDA 5 161.0	560001	NODAWAYCO 161.0	1	153	146.6	146.8	3.8%	S975 (Humboldt) T4 161-69	XS543015>543018>\$1
635034	CLRNDA 5 161.0	560001	NODAWAYCO 161.0	1	153	146.5	146.8	3.8%	S975 (Humboldt) T4 161-69	XS580070>580071>\$1
635034	CLRNDA 5 161.0	560001	NODAWAYCO 161.0	1	153	146.5	146.8	3.8%	S975 (Humboldt) T4 161-69	XS580070>648500>\$1
635034	CLRNDA 5 161.0	560001	NODAWAYCO 161.0	1	153	146.6	146.8	3.8%	S975 (Humboldt) T4 161-69	CB1253-35&37
635034	CLRNDA 5 161.0	560001	NODAWAYCO 161.0	1	153	146.6	146.8	3.8%	S975 (Humboldt) T4 161-69	CB1237-BUS

635034	CLRNDA 5 161.0	560001	NODAWAYCO 161.0	1	153	146.6	146.8	3.8%	S975 (Humboldt) T4 161-69	CB1209-311T1
635034	CLRNDA 5 161.0	560001	NODAWAYCO 161.0	1	153	146.6	146.8	3.8%	S975 (Humboldt) T4 161-69	CB939-09-MUD
635034	CLRNDA 5 161.0	560001	NODAWAYCO 161.0	1	153	146.6	146.8	3.8%	S1280 to Humboldt	XS636029>636036>\$1
635034	CLRNDA 5 161.0	560001	NODAWAYCO 161.0	1	153	146.6	146.8	3.8%	S1280 to Humboldt	XS640050>640096>\$1
635034	CLRNDA 5 161.0	560001	NODAWAYCO 161.0	1	153	146.6	146.8	3.8%	S1280 to Humboldt	XS640404>652484>\$1
635034	CLRNDA 5 161.0	560001	NODAWAYCO 161.0	1	153	146.6	146.8	3.8%	S1280 to Humboldt	XS647401>647962>\$1
635034	CLRNDA 5 161.0	560001	NODAWAYCO 161.0	1	153	146.6	146.8	3.8%	S1280 to Humboldt	XS300058>345034>\$1
635034	CLRNDA 5 161.0	560001	NODAWAYCO 161.0	1	153	146.6	146.8	3.8%	S1280 to Humboldt	XS300816>505498>\$1
635034	CLRNDA 5 161.0	560001	NODAWAYCO 161.0	1	153	146.6	146.8	3.8%	S1280 to Humboldt	XS532872>532873>\$1
635034	CLRNDA 5 161.0	560001	NODAWAYCO 161.0	1	153	146.6	146.8	3.8%	S1280 to Humboldt	XS300108>300816>\$1
635034	CLRNDA 5 161.0	560001	NODAWAYCO 161.0	1	153	146.6	146.8	3.8%	S1280 to Humboldt	XS533001>533674>533086\$1
635034	CLRNDA 5 161.0	560001	NODAWAYCO 161.0	1	153	146.6	146.8	3.8%	S1280 to Humboldt	XS533361>533887>\$1
635034	CLRNDA 5 161.0	560001	NODAWAYCO 161.0	1	153	146.6	146.8	3.8%	S1280 to Humboldt	XS652514>659205>\$1
635034	CLRNDA 5 161.0	560001	NODAWAYCO 161.0	1	153	146.6	146.8	3.8%	S1280 to Humboldt	XS541236>541244>\$1
635034	CLRNDA 5 161.0	560001	NODAWAYCO 161.0	1	153	146.6	146.8	3.8%	S1280 to Humboldt	XS543044>543056>\$1
635034	CLRNDA 5 161.0	560001	NODAWAYCO 161.0	1	153	146.6	146.8	3.8%	S1280 to Humboldt	XS533419>530618>\$1
635034	CLRNDA 5 161.0	560001	NODAWAYCO 161.0	1	153	146.6	146.8	3.8%	S1280 to Humboldt	XS541208>300070>\$1
635034	CLRNDA 5 161.0	560001	NODAWAYCO 161.0	1	153	146.6	146.8	3.8%	S1280 to Humboldt	XS541205>541235>\$1
635034	CLRNDA 5 161.0	560001	NODAWAYCO 161.0	1	153	146.6	146.8	3.8%	S975 (Humboldt) T4 161-69	XS640050>640025>\$1
635034	CLRNDA 5 161.0	560001	NODAWAYCO 161.0	1	153	146.6	146.8	3.8%	S975 (Humboldt) T4 161-69	XS542997>543010>\$1
635034	CLRNDA 5 161.0	560001	NODAWAYCO 161.0	1	153	146.4	146.7	5.7%	S1399 to Humboldt	CB3454-51&WG
635034	CLRNDA 5 161.0	560001	NODAWAYCO 161.0	1	153	146.4	146.7	4.8%	S1399 to Humboldt	XS635641>635653>\$1
635034	CLRNDA 5 161.0	560001	NODAWAYCO 161.0	1	153	146.4	146.7	4.8%	S1399 to Humboldt	XS640424>640425>643170\$1
635034	CLRNDA 5 161.0	560001	NODAWAYCO 161.0	1	153	146.4	146.7	4.8%	S1399 to Humboldt	XS650185>645454>\$1
635034	CLRNDA 5 161.0	560001	NODAWAYCO 161.0	1	153	146.4	146.7	4.8%	S1399 to Humboldt	XS300120>300002>\$1
635034	CLRNDA 5 161.0	560001	NODAWAYCO 161.0	1	153	146.4	146.7	4.8%	S1399 to Humboldt	CB1227-BUS

635034	CLRNDA 5 161.0	560001	NODAWAYCO 161.0	1	153	146.4	146.7	4.8%	S1399 to Humboldt	BKR-WAG-3006
635034	CLRNDA 5 161.0	560001	NODAWAYCO 161.0	1	153	146.4	146.7	4.8%	S1399 to Humboldt	CB3454-55&WG
635034	CLRNDA 5 161.0	560001	NODAWAYCO 161.0	1	153	146.4	146.7	4.8%	S1399 to Humboldt	XS542995>542954>\$1
635034	CLRNDA 5 161.0	560001	NODAWAYCO 161.0	1	153	146.4	146.7	3.8%	S1280 to Humboldt	XS631102>630023>\$1
635034	CLRNDA 5 161.0	560001	NODAWAYCO 161.0	1	153	146.4	146.7	3.8%	S1280 to Humboldt	XS631098>629091>\$1
635034	CLRNDA 5 161.0	560001	NODAWAYCO 161.0	1	153	146.4	146.7	3.8%	S1280 to Humboldt	XS636025>636026>\$1
635034	CLRNDA 5 161.0	560001	NODAWAYCO 161.0	1	153	146.4	146.7	3.8%	S1280 to Humboldt	XS635681>635703>\$1
635034	CLRNDA 5 161.0	560001	NODAWAYCO 161.0	1	153	146.4	146.7	3.8%	S1280 to Humboldt	XS635610>635611>\$2
635034	CLRNDA 5 161.0	560001	NODAWAYCO 161.0	1	153	146.4	146.7	3.8%	S1280 to Humboldt	XS631122>613040>\$1
635034	CLRNDA 5 161.0	560001	NODAWAYCO 161.0	1	153	146.4	146.7	3.8%	S1280 to Humboldt	XS636023>636025>\$1
635034	CLRNDA 5 161.0	560001	NODAWAYCO 161.0	1	153	146.4	146.7	3.8%	S1280 to Humboldt	XS631144>631157>\$1
635034	CLRNDA 5 161.0	560001	NODAWAYCO 161.0	1	153	146.4	146.7	3.8%	S1280 to Humboldt	XS631106>631108>\$1
635034	CLRNDA 5 161.0	560001	NODAWAYCO 161.0	1	153	146.4	146.7	3.8%	S1280 to Humboldt	XS635201>635203>\$1
635034	CLRNDA 5 161.0	560001	NODAWAYCO 161.0	1	153	146.4	146.7	3.8%	S1280 to Humboldt	XS631183>656570>\$1
635034	CLRNDA 5 161.0	560001	NODAWAYCO 161.0	1	153	146.4	146.7	3.8%	S1280 to Humboldt	XS635610>635611>\$1
635034	CLRNDA 5 161.0	560001	NODAWAYCO 161.0	1	153	146.5	146.7	3.8%	S1280 to Humboldt	XS635223>635260>\$1
635034	CLRNDA 5 161.0	560001	NODAWAYCO 161.0	1	153	146.4	146.7	3.8%	S1280 to Humboldt	XS631101>630024>\$1
635034	CLRNDA 5 161.0	560001	NODAWAYCO 161.0	1	153	146.4	146.7	3.8%	S1280 to Humboldt	XS636020>636023>\$1
635034	CLRNDA 5 161.0	560001	NODAWAYCO 161.0	1	153	146.4	146.7	3.8%	S1280 to Humboldt	XS631144>631158>\$1
635034	CLRNDA 5 161.0	560001	NODAWAYCO 161.0	1	153	146.5	146.7	3.8%	S1280 to Humboldt	XS635223>652566>\$1
635034	CLRNDA 5 161.0	560001	NODAWAYCO 161.0	1	153	146.4	146.7	3.8%	S1280 to Humboldt	XS631111>630036>\$1
635034	CLRNDA 5 161.0	560001	NODAWAYCO 161.0	1	153	146.4	146.7	3.8%	S1280 to Humboldt	XS635670>635671>\$2
635034	CLRNDA 5 161.0	560001	NODAWAYCO 161.0	1	153	146.4	146.7	3.8%	S1280 to Humboldt	XS631122>630139>\$1
635034	CLRNDA 5 161.0	560001	NODAWAYCO 161.0	1	153	146.4	146.7	3.8%	S1280 to Humboldt	XS635220>635221>\$1
635034	CLRNDA 5 161.0	560001	NODAWAYCO 161.0	1	153	146.4	146.7	3.8%	S1280 to Humboldt	XS631108>631109>\$1
635034	CLRNDA 5 161.0	560001	NODAWAYCO 161.0	1	153	146.5	146.7	3.8%	S1280 to Humboldt	XS635680>635700>\$1
635034	CLRNDA 5 161.0	560001	NODAWAYCO 161.0	1	153	146.4	146.7	3.8%	S1280 to Humboldt	XS635201>635203>\$2

635034	CLRNDA 5	161.0	560001	NODAWAYCO	161.0	1	153	146.5	146.7	3.8%	S1280 to Humboldt	XS635360>635361>\$1
635034	CLRNDA 5	161.0	560001	NODAWAYCO	161.0	1	153	146.4	146.7	3.8%	S1280 to Humboldt	XS631106>300439>\$2
635034	CLRNDA 5	161.0	560001	NODAWAYCO	161.0	1	153	146.4	146.7	3.8%	S1280 to Humboldt	XS636029>636030>\$1
635034	CLRNDA 5	161.0	560001	NODAWAYCO	161.0	1	153	146.4	146.7	3.8%	S1280 to Humboldt	XS635673>635681>\$1
635034	CLRNDA 5	161.0	560001	NODAWAYCO	161.0	1	153	146.5	146.7	3.8%	S1280 to Humboldt	XS635260>635261>\$1
635034	CLRNDA 5	161.0	560001	NODAWAYCO	161.0	1	153	146.4	146.7	3.8%	S1280 to Humboldt	XS631102>630023>\$2
635034	CLRNDA 5	161.0	560001	NODAWAYCO	161.0	1	153	146.5	146.7	3.8%	S1280 to Humboldt	XS635235>635236>\$1
635034	CLRNDA 5	161.0	560001	NODAWAYCO	161.0	1	153	146.4	146.7	3.8%	S1280 to Humboldt	XS631099>630022>\$1
635034	CLRNDA 5	161.0	560001	NODAWAYCO	161.0	1	153	146.4	146.7	3.8%	S1280 to Humboldt	XS631181>631182>\$1
635034	CLRNDA 5	161.0	560001	NODAWAYCO	161.0	1	153	146.4	146.7	3.8%	S1280 to Humboldt	XS631155>631169>\$1
635034	CLRNDA 5	161.0	560001	NODAWAYCO	161.0	1	153	146.4	146.7	3.8%	S1280 to Humboldt	XS635604>635610>\$1
635034	CLRNDA 5	161.0	560001	NODAWAYCO	161.0	1	153	146.4	146.7	3.8%	S1280 to Humboldt	XS635203>635204>\$1
635034	CLRNDA 5	161.0	560001	NODAWAYCO	161.0	1	153	146.4	146.7	3.8%	S1280 to Humboldt	XS631166>636230>\$1
635034	CLRNDA 5	161.0	560001	NODAWAYCO	161.0	1	153	146.4	146.7	3.8%	S1280 to Humboldt	XS635710>638000>\$1
635034	CLRNDA 5	161.0	560001	NODAWAYCO	161.0	1	153	146.4	146.7	3.8%	S1280 to Humboldt	XS631156>631153>\$1
635034	CLRNDA 5	161.0	560001	NODAWAYCO	161.0	1	153	146.4	146.7	3.8%	S1280 to Humboldt	XS631107>631119>\$1
635034	CLRNDA 5	161.0	560001	NODAWAYCO	161.0	1	153	146.4	146.7	3.8%	S1280 to Humboldt	XS631100>630019>\$1
635034	CLRNDA 5	161.0	560001	NODAWAYCO	161.0	1	153	146.4	146.7	3.8%	S1280 to Humboldt	XS631163>681529>\$1
635034	CLRNDA 5	161.0	560001	NODAWAYCO	161.0	1	153	146.5	146.7	3.8%	S1280 to Humboldt	XS635601>635605>\$1
635034	CLRNDA 5	161.0	560001	NODAWAYCO	161.0	1	153	146.4	146.7	3.8%	S1280 to Humboldt	XS631164>629984>\$1
635034	CLRNDA 5	161.0	560001	NODAWAYCO	161.0	1	153	146.4	146.7	3.8%	S1280 to Humboldt	XS631107>630046>\$1
635034	CLRNDA 5	161.0	560001	NODAWAYCO	161.0	1	153	146.5	146.7	3.8%	S1280 to Humboldt	XS635203>635235>\$1
635034	CLRNDA 5	161.0	560001	NODAWAYCO	161.0	1	153	146.5	146.7	3.8%	S1280 to Humboldt	XS635601>635602>\$1
635034	CLRNDA 5	161.0	560001	NODAWAYCO	161.0	1	153	146.4	146.7	3.8%	S1280 to Humboldt	XS631164>631183>\$1
635034	CLRNDA 5	161.0	560001	NODAWAYCO	161.0	1	153	146.4	146.7	3.8%	S1280 to Humboldt	XS631119>630053>\$1
635034	CLRNDA 5	161.0	560001	NODAWAYCO	161.0	1	153	146.4	146.7	3.8%	S1280 to Humboldt	XS635221>635222>\$1
635034	CLRNDA 5	161.0	560001	NODAWAYCO	161.0	1	153	146.5	146.7	3.8%	S1280 to Humboldt	XS635602>635603>\$1

635034	CLRNDA 5	161.0	560001	NODAWAYCO	161.0	1	153	146.5	146.7	3.8%	S1280 to Humboldt	XS631156>631175>\$1
635034	CLRNDA 5	161.0	560001	NODAWAYCO	161.0	1	153	146.4	146.7	3.8%	S1280 to Humboldt	XS635223>635224>\$1
635034	CLRNDA 5	161.0	560001	NODAWAYCO	161.0	1	153	146.4	146.7	3.8%	S1280 to Humboldt	XS631163>629983>\$1
635034	CLRNDA 5	161.0	560001	NODAWAYCO	161.0	1	153	146.4	146.7	3.8%	S1280 to Humboldt	XS635260>635360>\$1
635034	CLRNDA 5	161.0	560001	NODAWAYCO	161.0	1	153	146.4	146.7	3.8%	S1280 to Humboldt	XS635223>635226>\$1
635034	CLRNDA 5	161.0	560001	NODAWAYCO	161.0	1	153	146.4	146.7	3.8%	S1280 to Humboldt	XS636020>636021>\$3
635034	CLRNDA 5	161.0	560001	NODAWAYCO	161.0	1	153	146.4	146.7	3.8%	S1280 to Humboldt	XS631146>631147>\$1
635034	CLRNDA 5	161.0	560001	NODAWAYCO	161.0	1	153	146.4	146.7	3.8%	S1280 to Humboldt	XS631098>629091>\$2
635034	CLRNDA 5	161.0	560001	NODAWAYCO	161.0	1	153	146.4	146.7	3.8%	S1280 to Humboldt	XS635201>635220>\$1
635034	CLRNDA 5	161.0	560001	NODAWAYCO	161.0	1	153	146.5	146.7	3.8%	S1280 to Humboldt	XS635606>635607>\$1
635034	CLRNDA 5	161.0	560001	NODAWAYCO	161.0	1	153	146.4	146.7	3.8%	S1280 to Humboldt	XS631169>629987>\$1
635034	CLRNDA 5	161.0	560001	NODAWAYCO	161.0	1	153	146.4	146.7	3.8%	S1280 to Humboldt	XS631155>631152>\$1
635034	CLRNDA 5	161.0	560001	NODAWAYCO	161.0	1	153	146.4	146.7	3.8%	S1280 to Humboldt	XS635701>635703>\$1
635034	CLRNDA 5	161.0	560001	NODAWAYCO	161.0	1	153	146.4	146.7	3.8%	S1280 to Humboldt	XS636020>636021>\$2
635034	CLRNDA 5	161.0	560001	NODAWAYCO	161.0	1	153	146.4	146.7	3.8%	S1280 to Humboldt	XS631174>680542>\$1
635034	CLRNDA 5	161.0	560001	NODAWAYCO	161.0	1	153	146.4	146.7	3.8%	S1280 to Humboldt	XS636020>636021>\$1
635034	CLRNDA 5	161.0	560001	NODAWAYCO	161.0	1	153	146.4	146.7	3.8%	S1280 to Humboldt	XS635701>635702>\$2
635034	CLRNDA 5	161.0	560001	NODAWAYCO	161.0	1	153	146.4	146.7	3.8%	S1280 to Humboldt	XS631117>631119>\$1
635034	CLRNDA 5	161.0	560001	NODAWAYCO	161.0	1	153	146.4	146.7	3.8%	S1280 to Humboldt	XS635701>635702>\$1
635034	CLRNDA 5	161.0	560001	NODAWAYCO	161.0	1	153	146.4	146.7	3.8%	S1280 to Humboldt	XS631116>630047>\$1
635034	CLRNDA 5	161.0	560001	NODAWAYCO	161.0	1	153	146.5	146.7	3.8%	S1280 to Humboldt	XS635201>640377>\$1
635034	CLRNDA 5	161.0	560001	NODAWAYCO	161.0	1	153	146.4	146.7	3.8%	S1280 to Humboldt	XS636200>636225>\$1
635034	CLRNDA 5	161.0	560001	NODAWAYCO	161.0	1	153	146.4	146.7	3.8%	S1280 to Humboldt	XS631096>630018>\$1
635034	CLRNDA 5	161.0	560001	NODAWAYCO	161.0	1	153	146.5	146.7	3.8%	S1280 to Humboldt	XS631113>630050>\$1
635034	CLRNDA 5	161.0	560001	NODAWAYCO	161.0	1	153	146.4	146.7	3.8%	S1280 to Humboldt	XS631103>630821>\$1
635034	CLRNDA 5	161.0	560001	NODAWAYCO	161.0	1	153	146.4	146.7	3.8%	S1280 to Humboldt	XS636202>636203>\$1
635034	CLRNDA 5	161.0	560001	NODAWAYCO	161.0	1	153	146.4	146.7	3.8%	S1280 to Humboldt	XS631134>629985>\$1

635034	CLRNDA 5	161.0	560001	NODAWAYCO	161.0	1	153	146.4	146.7	3.8%	S1280 to Humboldt	XS635631>635641>\$1
635034	CLRNDA 5	161.0	560001	NODAWAYCO	161.0	1	153	146.5	146.7	3.8%	S1280 to Humboldt	XS635261>635262>\$1
635034	CLRNDA 5	161.0	560001	NODAWAYCO	161.0	1	153	146.4	146.7	3.8%	S1280 to Humboldt	XS631134>629985>\$2
635034	CLRNDA 5	161.0	560001	NODAWAYCO	161.0	1	153	146.4	146.7	3.8%	S1280 to Humboldt	XS631114>633241>\$1
635034	CLRNDA 5	161.0	560001	NODAWAYCO	161.0	1	153	146.4	146.7	3.8%	S1280 to Humboldt	XS636200>636205>\$1
635034	CLRNDA 5	161.0	560001	NODAWAYCO	161.0	1	153	146.5	146.7	3.8%	S1280 to Humboldt	XS635660>635661>\$1
635034	CLRNDA 5	161.0	560001	NODAWAYCO	161.0	1	153	146.5	146.7	3.8%	S1280 to Humboldt	XS631103>629084>\$1
635034	CLRNDA 5	161.0	560001	NODAWAYCO	161.0	1	153	146.4	146.7	3.8%	S1280 to Humboldt	XS636200>636202>\$1
635034	CLRNDA 5	161.0	560001	NODAWAYCO	161.0	1	153	146.4	146.7	3.8%	S1280 to Humboldt	XS636205>636206>\$1
635034	CLRNDA 5	161.0	560001	NODAWAYCO	161.0	1	153	146.4	146.7	3.8%	S1280 to Humboldt	XS631103>656423>\$1
635034	CLRNDA 5	161.0	560001	NODAWAYCO	161.0	1	153	146.4	146.7	3.8%	S1280 to Humboldt	XS636204>636210>\$1
635034	CLRNDA 5	161.0	560001	NODAWAYCO	161.0	1	153	146.4	146.7	3.8%	S1280 to Humboldt	XS631123>631127>\$1
635034	CLRNDA 5	161.0	560001	NODAWAYCO	161.0	1	153	146.4	146.7	3.8%	S1280 to Humboldt	XS631113>631117>\$1
635034	CLRNDA 5	161.0	560001	NODAWAYCO	161.0	1	153	146.4	146.7	3.8%	S1280 to Humboldt	XS636203>636206>\$1
635034	CLRNDA 5	161.0	560001	NODAWAYCO	161.0	1	153	146.4	146.7	3.8%	S1280 to Humboldt	XS631104>630030>\$1
635034	CLRNDA 5	161.0	560001	NODAWAYCO	161.0	1	153	146.4	146.7	3.8%	S1280 to Humboldt	XS631103>630821>\$2
635034	CLRNDA 5	161.0	560001	NODAWAYCO	161.0	1	153	146.4	146.7	3.8%	S1280 to Humboldt	XS631127>630128>\$1
635034	CLRNDA 5	161.0	560001	NODAWAYCO	161.0	1	153	146.4	146.7	3.8%	S1280 to Humboldt	XS636203>636204>\$1
635034	CLRNDA 5	161.0	560001	NODAWAYCO	161.0	1	153	146.4	146.7	3.8%	S1280 to Humboldt	XS635320>635321>\$2
635034	CLRNDA 5	161.0	560001	NODAWAYCO	161.0	1	153	146.5	146.7	3.8%	S1280 to Humboldt	XS631128>631156>\$1
635034	CLRNDA 5	161.0	560001	NODAWAYCO	161.0	1	153	146.4	146.7	3.8%	S1280 to Humboldt	XS631114>630052>\$1
635034	CLRNDA 5	161.0	560001	NODAWAYCO	161.0	1	153	146.4	146.7	3.8%	S1280 to Humboldt	XS635320>635321>\$1
635034	CLRNDA 5	161.0	560001	NODAWAYCO	161.0	1	153	146.4	146.7	3.8%	S1280 to Humboldt	XS635665>635666>\$2
635034	CLRNDA 5	161.0	560001	NODAWAYCO	161.0	1	153	146.4	146.7	3.8%	S1280 to Humboldt	XS635614>635701>\$1
635034	CLRNDA 5	161.0	560001	NODAWAYCO	161.0	1	153	146.4	146.7	3.8%	S1280 to Humboldt	XS631106>300439>\$1
635034	CLRNDA 5	161.0	560001	NODAWAYCO	161.0	1	153	146.4	146.7	3.8%	S1280 to Humboldt	XS631122>631123>\$1
635034	CLRNDA 5	161.0	560001	NODAWAYCO	161.0	1	153	146.4	146.7	3.8%	S1280 to Humboldt	XS635100>635101>\$2

635034	CLRNDA 5	161.0	560001	NODAWAYCO	161.0	1	153	146.4	146.7	3.8%	S1280 to Humboldt	XS635662>635664>\$1
635034	CLRNDA 5	161.0	560001	NODAWAYCO	161.0	1	153	146.4	146.7	3.8%	S1280 to Humboldt	XS635615>635616>\$1
635034	CLRNDA 5	161.0	560001	NODAWAYCO	161.0	1	153	146.4	146.7	3.8%	S1280 to Humboldt	XS631102>631183>\$1
635034	CLRNDA 5	161.0	560001	NODAWAYCO	161.0	1	153	146.5	146.7	3.8%	S1280 to Humboldt	XS635280>635281>\$1
635034	CLRNDA 5	161.0	560001	NODAWAYCO	161.0	1	153	146.4	146.7	3.8%	S1280 to Humboldt	XS635664>635665>\$1
635034	CLRNDA 5	161.0	560001	NODAWAYCO	161.0	1	153	146.4	146.7	3.8%	S1280 to Humboldt	XS631138>629992>\$1
635034	CLRNDA 5	161.0	560001	NODAWAYCO	161.0	1	153	146.4	146.7	3.8%	S1280 to Humboldt	XS635665>635666>\$1
635034	CLRNDA 5	161.0	560001	NODAWAYCO	161.0	1	153	146.5	146.7	3.8%	S1280 to Humboldt	XS631115>631116>\$1
635034	CLRNDA 5	161.0	560001	NODAWAYCO	161.0	1	153	146.5	146.7	3.8%	S1280 to Humboldt	XS631096>631098>\$1
635034	CLRNDA 5	161.0	560001	NODAWAYCO	161.0	1	153	146.4	146.7	3.8%	S1280 to Humboldt	XS635340>636029>\$1
635034	CLRNDA 5	161.0	560001	NODAWAYCO	161.0	1	153	146.5	146.7	3.8%	S1280 to Humboldt	XS635614>635615>\$1
635034	CLRNDA 5	161.0	560001	NODAWAYCO	161.0	1	153	146.4	146.7	3.8%	S1280 to Humboldt	XS636200>636201>\$1
635034	CLRNDA 5	161.0	560001	NODAWAYCO	161.0	1	153	146.4	146.7	3.8%	S1280 to Humboldt	XS631096>630018>\$2
635034	CLRNDA 5	161.0	560001	NODAWAYCO	161.0	1	153	146.4	146.7	3.8%	S1280 to Humboldt	XS635662>635663>\$1
635034	CLRNDA 5	161.0	560001	NODAWAYCO	161.0	1	153	146.5	146.7	3.8%	S1280 to Humboldt	XS635340>635341>\$1
635034	CLRNDA 5	161.0	560001	NODAWAYCO	161.0	1	153	146.4	146.7	3.8%	S1280 to Humboldt	XS635670>635671>\$1
635034	CLRNDA 5	161.0	560001	NODAWAYCO	161.0	1	153	146.4	146.7	3.8%	S1280 to Humboldt	XS635100>635101>\$1
635034	CLRNDA 5	161.0	560001	NODAWAYCO	161.0	1	153	146.4	146.7	3.8%	S1280 to Humboldt	XS631109>630037>\$1
635034	CLRNDA 5	161.0	560001	NODAWAYCO	161.0	1	153	146.4	146.7	3.8%	S1280 to Humboldt	XS631104>631134>\$1
635034	CLRNDA 5	161.0	560001	NODAWAYCO	161.0	1	153	146.4	146.7	3.8%	S1280 to Humboldt	XS635662>635663>\$2
635034	CLRNDA 5	161.0	560001	NODAWAYCO	161.0	1	153	146.4	146.7	3.8%	S1280 to Humboldt	XS631109>630038>\$1
635034	CLRNDA 5	161.0	560001	NODAWAYCO	161.0	1	153	146.4	146.7	3.8%	S1280 to Humboldt	XS631108>631109>\$2
635034	CLRNDA 5	161.0	560001	NODAWAYCO	161.0	1	153	146.4	146.7	3.8%	S1280 to Humboldt	XS635280>656570>\$1
635034	CLRNDA 5	161.0	560001	NODAWAYCO	161.0	1	153	146.4	146.7	3.8%	S1280 to Humboldt	XS640153>640278>\$1
635034	CLRNDA 5	161.0	560001	NODAWAYCO	161.0	1	153	146.4	146.7	3.8%	S1280 to Humboldt	XS636681>636682>\$1
635034	CLRNDA 5	161.0	560001	NODAWAYCO	161.0	1	153	146.4	146.7	3.8%	S1280 to Humboldt	XS640100>640269>\$1
635034	CLRNDA 5	161.0	560001	NODAWAYCO	161.0	1	153	146.4	146.7	3.8%	S1280 to Humboldt	XS636670>636675>\$1

635034	CLRNDA 5	161.0	560001	NODAWAYCO	161.0	1	153	146.4	146.7	3.8%	S1280 to Humboldt	XS636670>636671>\$3
635034	CLRNDA 5	161.0	560001	NODAWAYCO	161.0	1	153	146.4	146.7	3.8%	S1280 to Humboldt	XS636686>636687>\$1
635034	CLRNDA 5	161.0	560001	NODAWAYCO	161.0	1	153	146.4	146.7	3.8%	S1280 to Humboldt	XS636685>636690>\$1
635034	CLRNDA 5	161.0	560001	NODAWAYCO	161.0	1	153	146.4	146.7	3.8%	S1280 to Humboldt	XS636680>636681>\$1
635034	CLRNDA 5	161.0	560001	NODAWAYCO	161.0	1	153	146.4	146.7	3.8%	S1280 to Humboldt	XS636685>636686>\$1
635034	CLRNDA 5	161.0	560001	NODAWAYCO	161.0	1	153	146.4	146.7	3.8%	S1280 to Humboldt	XS636683>636685>\$1
635034	CLRNDA 5	161.0	560001	NODAWAYCO	161.0	1	153	146.4	146.7	3.8%	S1280 to Humboldt	XS636682>636683>\$1
635034	CLRNDA 5	161.0	560001	NODAWAYCO	161.0	1	153	146.4	146.7	3.8%	S1280 to Humboldt	XS640167>659244>\$1
635034	CLRNDA 5	161.0	560001	NODAWAYCO	161.0	1	153	146.4	146.7	3.8%	S1280 to Humboldt	XS636681>636685>\$1
635034	CLRNDA 5	161.0	560001	NODAWAYCO	161.0	1	153	146.4	146.7	3.8%	S1280 to Humboldt	XS640103>640161>\$1
635034	CLRNDA 5	161.0	560001	NODAWAYCO	161.0	1	153	146.4	146.7	3.8%	S1280 to Humboldt	XS636650>636651>\$2
635034	CLRNDA 5	161.0	560001	NODAWAYCO	161.0	1	153	146.4	146.7	3.8%	S1280 to Humboldt	XS640103>640005>\$1
635034	CLRNDA 5	161.0	560001	NODAWAYCO	161.0	1	153	146.4	146.7	3.8%	S1280 to Humboldt	XS640107>640108>\$1
635034	CLRNDA 5	161.0	560001	NODAWAYCO	161.0	1	153	146.4	146.7	3.8%	S1280 to Humboldt	XS636650>636692>\$1
635034	CLRNDA 5	161.0	560001	NODAWAYCO	161.0	1	153	146.4	146.7	3.8%	S1280 to Humboldt	XS640107>640108>\$2
635034	CLRNDA 5	161.0	560001	NODAWAYCO	161.0	1	153	146.4	146.7	3.8%	S1280 to Humboldt	XS636650>636657>\$1
635034	CLRNDA 5	161.0	560001	NODAWAYCO	161.0	1	153	146.4	146.7	3.8%	S1280 to Humboldt	XS640153>640154>\$2
635034	CLRNDA 5	161.0	560001	NODAWAYCO	161.0	1	153	146.4	146.7	3.8%	S1280 to Humboldt	XS640153>640154>\$1
635034	CLRNDA 5	161.0	560001	NODAWAYCO	161.0	1	153	146.5	146.7	3.8%	S1280 to Humboldt	XS640076>640361>\$1
635034	CLRNDA 5	161.0	560001	NODAWAYCO	161.0	1	153	146.5	146.7	3.8%	S1280 to Humboldt	XS640171>640362>\$1
635034	CLRNDA 5	161.0	560001	NODAWAYCO	161.0	1	153	146.4	146.7	3.8%	S1280 to Humboldt	XS640103>640242>\$2
635034	CLRNDA 5	161.0	560001	NODAWAYCO	161.0	1	153	146.4	146.7	3.8%	S1280 to Humboldt	XS636670>636671>\$1
635034	CLRNDA 5	161.0	560001	NODAWAYCO	161.0	1	153	146.4	146.7	3.8%	S1280 to Humboldt	XS636668>636694>\$1
635034	CLRNDA 5	161.0	560001	NODAWAYCO	161.0	1	153	146.4	146.7	3.8%	S1280 to Humboldt	XS640103>640242>\$1
635034	CLRNDA 5	161.0	560001	NODAWAYCO	161.0	1	153	146.5	146.7	3.8%	S1280 to Humboldt	XS640105>640218>\$1
635034	CLRNDA 5	161.0	560001	NODAWAYCO	161.0	1	153	146.4	146.7	3.8%	S1280 to Humboldt	XS636670>636671>\$2
635034	CLRNDA 5	161.0	560001	NODAWAYCO	161.0	1	153	146.4	146.7	3.8%	S1280 to Humboldt	XS636665>636667>\$1

635034	CLRND 5	161.0	560001	NODAWAYCO	161.0	1	153	146.4	146.7	3.8%	S1280 to Humboldt	XS640103>640256>\$1
635034	CLRND 5	161.0	560001	NODAWAYCO	161.0	1	153	146.4	146.7	3.8%	S1280 to Humboldt	XS636665>636666>\$1
635034	CLRND 5	161.0	560001	NODAWAYCO	161.0	1	153	146.4	146.7	3.8%	S1280 to Humboldt	XS636662>636665>\$1
635034	CLRND 5	161.0	560001	NODAWAYCO	161.0	1	153	146.4	146.7	3.8%	S1280 to Humboldt	XS636660>636662>\$1
635034	CLRND 5	161.0	560001	NODAWAYCO	161.0	1	153	146.4	146.7	3.8%	S1280 to Humboldt	XS636668>636670>\$1
635034	CLRND 5	161.0	560001	NODAWAYCO	161.0	1	153	146.5	146.7	3.8%	S1280 to Humboldt	XS640065>640066>640067\$1
635034	CLRND 5	161.0	560001	NODAWAYCO	161.0	1	153	146.5	146.7	3.8%	S1280 to Humboldt	XS640089>640259>\$1
635034	CLRND 5	161.0	560001	NODAWAYCO	161.0	1	153	146.4	146.7	3.8%	S1280 to Humboldt	XS640066>640275>\$1
635034	CLRND 5	161.0	560001	NODAWAYCO	161.0	1	153	146.4	146.7	3.8%	S1280 to Humboldt	XS640066>640250>\$1
635034	CLRND 5	161.0	560001	NODAWAYCO	161.0	1	153	146.4	146.7	3.8%	S1280 to Humboldt	XS640066>640224>\$1
635034	CLRND 5	161.0	560001	NODAWAYCO	161.0	1	153	146.4	146.7	3.8%	S1280 to Humboldt	XS640068>640246>\$1
635034	CLRND 5	161.0	560001	NODAWAYCO	161.0	1	153	146.4	146.7	3.8%	S1280 to Humboldt	XS640063>640411>\$1
635034	CLRND 5	161.0	560001	NODAWAYCO	161.0	1	153	146.4	146.7	3.8%	S1280 to Humboldt	XS640063>640201>\$1
635034	CLRND 5	161.0	560001	NODAWAYCO	161.0	1	153	146.4	146.7	3.8%	S1280 to Humboldt	XS640086>659193>\$1
635034	CLRND 5	161.0	560001	NODAWAYCO	161.0	1	153	146.4	146.7	3.8%	S1280 to Humboldt	XS640161>640250>\$1
635034	CLRND 5	161.0	560001	NODAWAYCO	161.0	1	153	146.4	146.7	3.8%	S1280 to Humboldt	XS640155>650269>\$1
635034	CLRND 5	161.0	560001	NODAWAYCO	161.0	1	153	146.4	146.7	3.8%	S1280 to Humboldt	XS640080>640387>\$1
635034	CLRND 5	161.0	560001	NODAWAYCO	161.0	1	153	146.4	146.7	3.8%	S1280 to Humboldt	XS640078>640357>\$1
635034	CLRND 5	161.0	560001	NODAWAYCO	161.0	1	153	146.4	146.7	3.8%	S1280 to Humboldt	XS640080>640212>\$1
635034	CLRND 5	161.0	560001	NODAWAYCO	161.0	1	153	146.4	146.7	3.8%	S1280 to Humboldt	XS640076>640077>\$1
635034	CLRND 5	161.0	560001	NODAWAYCO	161.0	1	153	146.4	146.7	3.8%	S1280 to Humboldt	XS640159>640282>\$1
635034	CLRND 5	161.0	560001	NODAWAYCO	161.0	1	153	146.4	146.7	3.8%	S1280 to Humboldt	XS640068>640091>\$1
635034	CLRND 5	161.0	560001	NODAWAYCO	161.0	1	153	146.4	146.7	3.8%	S1280 to Humboldt	XS640157>640402>\$1
635034	CLRND 5	161.0	560001	NODAWAYCO	161.0	1	153	146.4	146.7	3.8%	S1280 to Humboldt	XS640082>640083>\$1
635034	CLRND 5	161.0	560001	NODAWAYCO	161.0	1	153	146.4	146.7	3.8%	S1280 to Humboldt	XS640082>640083>\$2
635034	CLRND 5	161.0	560001	NODAWAYCO	161.0	1	153	146.4	146.7	3.8%	S1280 to Humboldt	XS640159>642071>\$1
635034	CLRND 5	161.0	560001	NODAWAYCO	161.0	1	153	146.4	146.7	3.8%	S1280 to Humboldt	XS640080>640228>\$1

635034	CLRND 5	161.0	560001	NODAWAYCO	161.0	1	153	146.4	146.7	3.8%	S1280 to Humboldt	XS638030>638040>\$1
635034	CLRND 5	161.0	560001	NODAWAYCO	161.0	1	153	146.4	146.7	3.8%	S1280 to Humboldt	XS640089>640090>\$1
635034	CLRND 5	161.0	560001	NODAWAYCO	161.0	1	153	146.4	146.7	3.8%	S1280 to Humboldt	XS640076>640077>\$2
635034	CLRND 5	161.0	560001	NODAWAYCO	161.0	1	153	146.4	146.7	3.8%	S1280 to Humboldt	XS638050>638051>\$2
635034	CLRND 5	161.0	560001	NODAWAYCO	161.0	1	153	146.4	146.7	3.8%	S1280 to Humboldt	XS640089>640090>\$2
635034	CLRND 5	161.0	560001	NODAWAYCO	161.0	1	153	146.4	146.7	3.8%	S1280 to Humboldt	XS640155>640402>\$1
635034	CLRND 5	161.0	560001	NODAWAYCO	161.0	1	153	146.5	146.7	3.8%	S1280 to Humboldt	XS638030>638031>\$1
635034	CLRND 5	161.0	560001	NODAWAYCO	161.0	1	153	146.4	146.7	3.8%	S1280 to Humboldt	XS638010>638011>\$1
635034	CLRND 5	161.0	560001	NODAWAYCO	161.0	1	153	146.4	146.7	3.8%	S1280 to Humboldt	XS638000>638010>\$1
635034	CLRND 5	161.0	560001	NODAWAYCO	161.0	1	153	146.4	146.7	3.8%	S1280 to Humboldt	XS638000>638001>\$1
635034	CLRND 5	161.0	560001	NODAWAYCO	161.0	1	153	146.4	146.7	3.8%	S1280 to Humboldt	XS636692>636693>\$1
635034	CLRND 5	161.0	560001	NODAWAYCO	161.0	1	153	146.4	146.7	3.8%	S1280 to Humboldt	XS638050>638051>\$1
635034	CLRND 5	161.0	560001	NODAWAYCO	161.0	1	153	146.4	146.7	3.8%	S1280 to Humboldt	XS636636>636670>\$2
635034	CLRND 5	161.0	560001	NODAWAYCO	161.0	1	153	146.4	146.7	3.8%	S1280 to Humboldt	XS640056>640057>\$2
635034	CLRND 5	161.0	560001	NODAWAYCO	161.0	1	153	146.4	146.7	3.8%	S1280 to Humboldt	XS640056>640057>\$1
635034	CLRND 5	161.0	560001	NODAWAYCO	161.0	1	153	146.4	146.7	3.8%	S1280 to Humboldt	XS640144>640196>\$1
635034	CLRND 5	161.0	560001	NODAWAYCO	161.0	1	153	146.5	146.7	3.8%	S1280 to Humboldt	XS640054>640181>\$1
635034	CLRND 5	161.0	560001	NODAWAYCO	161.0	1	153	146.4	146.7	3.8%	S1280 to Humboldt	XS640054>640055>\$2
635034	CLRND 5	161.0	560001	NODAWAYCO	161.0	1	153	146.4	146.7	3.8%	S1280 to Humboldt	XS640054>640055>\$1
635034	CLRND 5	161.0	560001	NODAWAYCO	161.0	1	153	146.4	146.7	3.8%	S1280 to Humboldt	XS640051>640392>\$1
635034	CLRND 5	161.0	560001	NODAWAYCO	161.0	1	153	146.4	146.7	3.8%	S1280 to Humboldt	XS636415>636425>\$1
635034	CLRND 5	161.0	560001	NODAWAYCO	161.0	1	153	146.4	146.7	3.8%	S1280 to Humboldt	XS640127>640136>\$1
635034	CLRND 5	161.0	560001	NODAWAYCO	161.0	1	153	146.4	146.7	3.8%	S1280 to Humboldt	XS636401>636423>\$1
635034	CLRND 5	161.0	560001	NODAWAYCO	161.0	1	153	146.5	146.7	3.8%	S1280 to Humboldt	XS640136>640008>\$1
635034	CLRND 5	161.0	560001	NODAWAYCO	161.0	1	153	146.5	146.7	3.8%	S1280 to Humboldt	XS640136>640007>\$1
635034	CLRND 5	161.0	560001	NODAWAYCO	161.0	1	153	146.5	146.7	3.8%	S1280 to Humboldt	XS640136>640006>\$1
635034	CLRND 5	161.0	560001	NODAWAYCO	161.0	1	153	146.4	146.7	3.8%	S1280 to Humboldt	XS636403>636404>\$1

635034	CLRND 5	161.0	560001	NODAWAYCO	161.0	1	153	146.4	146.7	3.8%	S1280 to Humboldt	XS636404>636405>\$1
635034	CLRND 5	161.0	560001	NODAWAYCO	161.0	1	153	146.4	146.7	3.8%	S1280 to Humboldt	XS636405>636410>\$1
635034	CLRND 5	161.0	560001	NODAWAYCO	161.0	1	153	146.4	146.7	3.8%	S1280 to Humboldt	XS636410>636411>\$1
635034	CLRND 5	161.0	560001	NODAWAYCO	161.0	1	153	146.4	146.7	3.8%	S1280 to Humboldt	XS640136>640137>\$1
635034	CLRND 5	161.0	560001	NODAWAYCO	161.0	1	153	146.4	146.7	3.8%	S1280 to Humboldt	XS636650>636651>\$1
635034	CLRND 5	161.0	560001	NODAWAYCO	161.0	1	153	146.4	146.7	3.8%	S1280 to Humboldt	XS636600>636635>\$1
635034	CLRND 5	161.0	560001	NODAWAYCO	161.0	1	153	146.4	146.7	3.8%	S1280 to Humboldt	XS640149>640293>\$1
635034	CLRND 5	161.0	560001	NODAWAYCO	161.0	1	153	146.5	146.7	3.8%	S1280 to Humboldt	XS636600>636601>\$1
635034	CLRND 5	161.0	560001	NODAWAYCO	161.0	1	153	146.4	146.7	3.8%	S1280 to Humboldt	XS640127>640157>\$1
635034	CLRND 5	161.0	560001	NODAWAYCO	161.0	1	153	146.4	146.7	3.8%	S1280 to Humboldt	XS636410>636415>\$1
635034	CLRND 5	161.0	560001	NODAWAYCO	161.0	1	153	146.4	146.7	3.8%	S1280 to Humboldt	XS636423>636425>\$1
635034	CLRND 5	161.0	560001	NODAWAYCO	161.0	1	153	146.4	146.7	3.8%	S1280 to Humboldt	XS636410>636422>\$1
635034	CLRND 5	161.0	560001	NODAWAYCO	161.0	1	153	146.4	146.7	3.8%	S1280 to Humboldt	XS636421>636422>\$1
635034	CLRND 5	161.0	560001	NODAWAYCO	161.0	1	153	146.5	146.7	3.8%	S1280 to Humboldt	XS636421>630679>\$1
635034	CLRND 5	161.0	560001	NODAWAYCO	161.0	1	153	146.4	146.7	3.8%	S1280 to Humboldt	XS636420>636421>\$1
635034	CLRND 5	161.0	560001	NODAWAYCO	161.0	1	153	146.4	146.7	3.8%	S1280 to Humboldt	XS640131>640132>643040\$2
635034	CLRND 5	161.0	560001	NODAWAYCO	161.0	1	153	146.4	146.7	3.8%	S1280 to Humboldt	XS640131>640133>\$1
635034	CLRND 5	161.0	560001	NODAWAYCO	161.0	1	153	146.4	146.7	3.8%	S1280 to Humboldt	XS636401>636402>\$2
635034	CLRND 5	161.0	560001	NODAWAYCO	161.0	1	153	146.4	146.7	3.8%	S1280 to Humboldt	XS636425>636426>\$1
635034	CLRND 5	161.0	560001	NODAWAYCO	161.0	1	153	146.4	146.7	3.8%	S1280 to Humboldt	XS636205>636207>\$1
635034	CLRND 5	161.0	560001	NODAWAYCO	161.0	1	153	146.4	146.7	3.8%	S1280 to Humboldt	XS636207>636208>\$1
635034	CLRND 5	161.0	560001	NODAWAYCO	161.0	1	153	146.4	146.7	3.8%	S1280 to Humboldt	XS640144>640407>\$1
635034	CLRND 5	161.0	560001	NODAWAYCO	161.0	1	153	146.4	146.7	3.8%	S1280 to Humboldt	XS636208>636220>\$1
635034	CLRND 5	161.0	560001	NODAWAYCO	161.0	1	153	146.4	146.7	3.8%	S1280 to Humboldt	XS640143>647973>\$1
635034	CLRND 5	161.0	560001	NODAWAYCO	161.0	1	153	146.4	146.7	3.8%	S1280 to Humboldt	XS636208>638040>\$1
635034	CLRND 5	161.0	560001	NODAWAYCO	161.0	1	153	146.4	146.7	3.8%	S1280 to Humboldt	XS636210>636211>\$1
635034	CLRND 5	161.0	560001	NODAWAYCO	161.0	1	153	146.4	146.7	3.8%	S1280 to Humboldt	XS640140>640446>643173\$1

635034	CLRND 5	161.0	560001	NODAWAYCO	161.0	1	153	146.4	146.7	3.8%	S1280 to Humboldt	XS636220>636222>\$1
635034	CLRND 5	161.0	560001	NODAWAYCO	161.0	1	153	146.4	146.7	3.8%	S1280 to Humboldt	XS640181>640182>\$2
635034	CLRND 5	161.0	560001	NODAWAYCO	161.0	1	153	146.4	146.7	3.8%	S1280 to Humboldt	XS636220>636223>\$1
635034	CLRND 5	161.0	560001	NODAWAYCO	161.0	1	153	146.4	146.7	3.8%	S1280 to Humboldt	XS636401>636403>\$1
635034	CLRND 5	161.0	560001	NODAWAYCO	161.0	1	153	146.4	146.7	3.8%	S1280 to Humboldt	XS640136>640137>\$2
635034	CLRND 5	161.0	560001	NODAWAYCO	161.0	1	153	146.4	146.7	3.8%	S1280 to Humboldt	XS636401>636402>\$1
635034	CLRND 5	161.0	560001	NODAWAYCO	161.0	1	153	146.4	146.7	3.8%	S1280 to Humboldt	XS640178>640372>\$1
635034	CLRND 5	161.0	560001	NODAWAYCO	161.0	1	153	146.4	146.7	3.8%	S1280 to Humboldt	XS636235>636236>\$1
635034	CLRND 5	161.0	560001	NODAWAYCO	161.0	1	153	146.4	146.7	3.8%	S1280 to Humboldt	XS640181>640182>\$1
635034	CLRND 5	161.0	560001	NODAWAYCO	161.0	1	153	146.4	146.7	3.8%	S1280 to Humboldt	XS640131>640132>643039\$1
635034	CLRND 5	161.0	560001	NODAWAYCO	161.0	1	153	146.4	146.7	3.8%	S1280 to Humboldt	XS640113>640293>\$1
635034	CLRND 5	161.0	560001	NODAWAYCO	161.0	1	153	146.4	146.7	3.8%	S1280 to Humboldt	XS640119>640122>\$2
635034	CLRND 5	161.0	560001	NODAWAYCO	161.0	1	153	146.4	146.7	3.8%	S1280 to Humboldt	XS636611>636690>\$1
635034	CLRND 5	161.0	560001	NODAWAYCO	161.0	1	153	146.4	146.7	3.8%	S1280 to Humboldt	XS640119>640122>\$1
635034	CLRND 5	161.0	560001	NODAWAYCO	161.0	1	153	146.4	146.7	3.8%	S1280 to Humboldt	XS640151>640152>\$2
635034	CLRND 5	161.0	560001	NODAWAYCO	161.0	1	153	146.4	146.7	3.8%	S1280 to Humboldt	XS636601>636602>\$1
635034	CLRND 5	161.0	560001	NODAWAYCO	161.0	1	153	146.4	146.7	3.8%	S1280 to Humboldt	XS636616>636617>\$1
635034	CLRND 5	161.0	560001	NODAWAYCO	161.0	1	153	146.4	146.7	3.8%	S1280 to Humboldt	XS636616>636618>\$2
635034	CLRND 5	161.0	560001	NODAWAYCO	161.0	1	153	146.4	146.7	3.8%	S1280 to Humboldt	XS636616>636626>\$1
635034	CLRND 5	161.0	560001	NODAWAYCO	161.0	1	153	146.4	146.7	3.8%	S1280 to Humboldt	XS640113>640305>\$1
635034	CLRND 5	161.0	560001	NODAWAYCO	161.0	1	153	146.4	146.7	3.8%	S1280 to Humboldt	XS636611>636687>\$1
635034	CLRND 5	161.0	560001	NODAWAYCO	161.0	1	153	146.4	146.7	3.8%	S1280 to Humboldt	XS636636>636670>\$1
635034	CLRND 5	161.0	560001	NODAWAYCO	161.0	1	153	146.4	146.7	3.8%	S1280 to Humboldt	XS636625>636628>\$1
635034	CLRND 5	161.0	560001	NODAWAYCO	161.0	1	153	146.4	146.7	3.8%	S1280 to Humboldt	XS636616>636675>\$1
635034	CLRND 5	161.0	560001	NODAWAYCO	161.0	1	153	146.4	146.7	3.8%	S1280 to Humboldt	XS640109>640405>\$1
635034	CLRND 5	161.0	560001	NODAWAYCO	161.0	1	153	146.4	146.7	3.8%	S1280 to Humboldt	XS640173>640409>\$1
635034	CLRND 5	161.0	560001	NODAWAYCO	161.0	1	153	146.4	146.7	3.8%	S1280 to Humboldt	XS640151>640263>\$1

635034	CLRND 5	161.0	560001	NODAWAYCO	161.0	1	153	146.4	146.7	3.8%	S1280 to Humboldt	XS640109>652311>\$1
635034	CLRND 5	161.0	560001	NODAWAYCO	161.0	1	153	146.4	146.7	3.8%	S1280 to Humboldt	XS636616>636680>\$1
635034	CLRND 5	161.0	560001	NODAWAYCO	161.0	1	153	146.4	146.7	3.8%	S1280 to Humboldt	XS640173>647976>\$1
635034	CLRND 5	161.0	560001	NODAWAYCO	161.0	1	153	146.4	146.7	3.8%	S1280 to Humboldt	XS640151>640152>\$1
635034	CLRND 5	161.0	560001	NODAWAYCO	161.0	1	153	146.4	146.7	3.8%	S1280 to Humboldt	XS640125>640127>640129\$1
635034	CLRND 5	161.0	560001	NODAWAYCO	161.0	1	153	146.4	146.7	3.8%	S1280 to Humboldt	XS640126>640133>\$1
635034	CLRND 5	161.0	560001	NODAWAYCO	161.0	1	153	146.4	146.7	3.8%	S1280 to Humboldt	XS636601>636660>\$1
635034	CLRND 5	161.0	560001	NODAWAYCO	161.0	1	153	146.4	146.7	3.8%	S1280 to Humboldt	XS640127>640128>\$1
635034	CLRND 5	161.0	560001	NODAWAYCO	161.0	1	153	146.4	146.7	3.8%	S1280 to Humboldt	XS636601>636694>\$1
635034	CLRND 5	161.0	560001	NODAWAYCO	161.0	1	153	146.4	146.7	3.8%	S1280 to Humboldt	XS636605>274698>\$1
635034	CLRND 5	161.0	560001	NODAWAYCO	161.0	1	153	146.4	146.7	3.8%	S1280 to Humboldt	XS636605>270867>\$1
635034	CLRND 5	161.0	560001	NODAWAYCO	161.0	1	153	146.4	146.7	3.8%	S1280 to Humboldt	XS640126>640127>643036\$1
635034	CLRND 5	161.0	560001	NODAWAYCO	161.0	1	153	146.4	146.7	3.8%	S1280 to Humboldt	XS636605>274698>\$2
635034	CLRND 5	161.0	560001	NODAWAYCO	161.0	1	153	146.4	146.7	3.8%	S1280 to Humboldt	XS640124>640328>\$1
635034	CLRND 5	161.0	560001	NODAWAYCO	161.0	1	153	146.4	146.7	3.8%	S1280 to Humboldt	XS640124>640136>\$1
635034	CLRND 5	161.0	560001	NODAWAYCO	161.0	1	153	146.4	146.7	3.8%	S1280 to Humboldt	XS640127>640128>\$2
635034	CLRND 5	161.0	560001	NODAWAYCO	161.0	1	153	146.4	146.7	3.8%	S1280 to Humboldt	XS640119>640127>\$1
635034	CLRND 5	161.0	560001	NODAWAYCO	161.0	1	153	146.4	146.7	3.8%	S1280 to Humboldt	XS640173>647976>\$4
635034	CLRND 5	161.0	560001	NODAWAYCO	161.0	1	153	146.4	146.7	3.8%	S1280 to Humboldt	XS640119>640124>\$1
635034	CLRND 5	161.0	560001	NODAWAYCO	161.0	1	153	146.4	146.7	3.8%	S1280 to Humboldt	XS640286>640287>640291\$2
635034	CLRND 5	161.0	560001	NODAWAYCO	161.0	1	153	146.4	146.7	3.8%	S1280 to Humboldt	XS640286>640287>640290\$1
635034	CLRND 5	161.0	560001	NODAWAYCO	161.0	1	153	146.4	146.7	3.8%	S1280 to Humboldt	XS640215>641088>\$1
635034	CLRND 5	161.0	560001	NODAWAYCO	161.0	1	153	146.5	146.7	3.8%	S1280 to Humboldt	XS640196>640238>\$1
635034	CLRND 5	161.0	560001	NODAWAYCO	161.0	1	153	146.4	146.7	3.8%	S1280 to Humboldt	XS641082>641084>\$1
635034	CLRND 5	161.0	560001	NODAWAYCO	161.0	1	153	146.4	146.7	3.8%	S1280 to Humboldt	XS640282>641082>\$1
635034	CLRND 5	161.0	560001	NODAWAYCO	161.0	1	153	146.4	146.7	3.8%	S1280 to Humboldt	XS640240>640244>\$1
635034	CLRND 5	161.0	560001	NODAWAYCO	161.0	1	153	146.4	146.7	3.8%	S1280 to Humboldt	XS640218>640012>\$1

635034	CLRNDA 5	161.0	560001	NODAWAYCO	161.0	1	153	146.4	146.7	3.8%	S1280 to Humboldt	XS640200>640201>640203\$1
635034	CLRNDA 5	161.0	560001	NODAWAYCO	161.0	1	153	146.5	146.7	3.8%	S1280 to Humboldt	XS640226>640228>640231\$1
635034	CLRNDA 5	161.0	560001	NODAWAYCO	161.0	1	153	146.4	146.7	3.8%	S1280 to Humboldt	XS641083>641084>\$1
635034	CLRNDA 5	161.0	560001	NODAWAYCO	161.0	1	153	146.4	146.7	3.8%	S1280 to Humboldt	XS640248>640250>\$1
635034	CLRNDA 5	161.0	560001	NODAWAYCO	161.0	1	153	146.4	146.7	3.8%	S1280 to Humboldt	XS641083>641090>\$1
635034	CLRNDA 5	161.0	560001	NODAWAYCO	161.0	1	153	146.5	146.7	3.8%	S1280 to Humboldt	XS640218>640220>\$1
635034	CLRNDA 5	161.0	560001	NODAWAYCO	161.0	1	153	146.4	146.7	3.8%	S1280 to Humboldt	XS640340>640341>\$2
635034	CLRNDA 5	161.0	560001	NODAWAYCO	161.0	1	153	146.4	146.7	3.8%	S1280 to Humboldt	XS645032>647906>\$1
635034	CLRNDA 5	161.0	560001	NODAWAYCO	161.0	1	153	146.4	146.7	3.8%	S1280 to Humboldt	XS640248>640331>\$1
635034	CLRNDA 5	161.0	560001	NODAWAYCO	161.0	1	153	146.5	146.7	3.8%	S1280 to Humboldt	XS640183>640374>\$2
635034	CLRNDA 5	161.0	560001	NODAWAYCO	161.0	1	153	146.4	146.7	3.8%	S1280 to Humboldt	XS641082>641085>\$1
635034	CLRNDA 5	161.0	560001	NODAWAYCO	161.0	1	153	146.4	146.7	3.8%	S1280 to Humboldt	XS640278>640021>\$1
635034	CLRNDA 5	161.0	560001	NODAWAYCO	161.0	1	153	146.4	146.7	3.8%	S1280 to Humboldt	XS640215>640216>\$2
635034	CLRNDA 5	161.0	560001	NODAWAYCO	161.0	1	153	146.4	146.7	3.8%	S1280 to Humboldt	XS640298>640299>\$2
635034	CLRNDA 5	161.0	560001	NODAWAYCO	161.0	1	153	146.4	146.7	3.8%	S1280 to Humboldt	XS640298>640299>\$1
635034	CLRNDA 5	161.0	560001	NODAWAYCO	161.0	1	153	146.4	146.7	3.8%	S1280 to Humboldt	XS640296>640298>\$1
635034	CLRNDA 5	161.0	560001	NODAWAYCO	161.0	1	153	146.4	146.7	3.8%	S1280 to Humboldt	XS640200>640214>\$1
635034	CLRNDA 5	161.0	560001	NODAWAYCO	161.0	1	153	146.4	146.7	3.8%	S1280 to Humboldt	XS640296>640297>\$2
635034	CLRNDA 5	161.0	560001	NODAWAYCO	161.0	1	153	146.4	146.7	3.8%	S1280 to Humboldt	XS640215>640313>\$1
635034	CLRNDA 5	161.0	560001	NODAWAYCO	161.0	1	153	146.4	146.7	3.8%	S1280 to Humboldt	XS640242>640244>\$1
635034	CLRNDA 5	161.0	560001	NODAWAYCO	161.0	1	153	146.4	146.7	3.8%	S1280 to Humboldt	XS640296>640297>\$1
635034	CLRNDA 5	161.0	560001	NODAWAYCO	161.0	1	153	146.4	146.7	3.8%	S1280 to Humboldt	XS645052>647901>\$1
635034	CLRNDA 5	161.0	560001	NODAWAYCO	161.0	1	153	146.4	146.7	3.8%	S1280 to Humboldt	XS640246>652300>\$1
635034	CLRNDA 5	161.0	560001	NODAWAYCO	161.0	1	153	146.4	146.7	3.8%	S1280 to Humboldt	XS640215>640313>\$2
635034	CLRNDA 5	161.0	560001	NODAWAYCO	161.0	1	153	146.4	146.7	3.8%	S1280 to Humboldt	XS640250>640251>\$1
635034	CLRNDA 5	161.0	560001	NODAWAYCO	161.0	1	153	146.4	146.7	3.8%	S1280 to Humboldt	XS640215>641087>\$1
635034	CLRNDA 5	161.0	560001	NODAWAYCO	161.0	1	153	146.5	146.7	3.8%	S1280 to Humboldt	XS640411>640413>\$1

635034	CLRND 5	161.0	560001	NODAWAYCO	161.0	1	153	146.4	146.7	3.8%	S1280 to Humboldt	XS640404>640405>640406\$1
635034	CLRND 5	161.0	560001	NODAWAYCO	161.0	1	153	146.4	146.7	3.8%	S1280 to Humboldt	XS645051>647901>\$1
635034	CLRND 5	161.0	560001	NODAWAYCO	161.0	1	153	146.4	146.7	3.8%	S1280 to Humboldt	XS640200>640201>643070\$2
635034	CLRND 5	161.0	560001	NODAWAYCO	161.0	1	153	146.4	146.7	3.8%	S1280 to Humboldt	XS640242>640407>\$1
635034	CLRND 5	161.0	560001	NODAWAYCO	161.0	1	153	146.5	146.7	3.8%	S1280 to Humboldt	XS640292>647961>\$1
635034	CLRND 5	161.0	560001	NODAWAYCO	161.0	1	153	146.4	146.7	3.8%	S1280 to Humboldt	XS640253>659132>\$1
635034	CLRND 5	161.0	560001	NODAWAYCO	161.0	1	153	146.4	146.7	3.8%	S1280 to Humboldt	XS641085>641088>\$1
635034	CLRND 5	161.0	560001	NODAWAYCO	161.0	1	153	146.4	146.7	3.8%	S1280 to Humboldt	XS642068>642071>\$1
635034	CLRND 5	161.0	560001	NODAWAYCO	161.0	1	153	146.4	146.7	3.8%	S1280 to Humboldt	XS640269>640017>\$1
635034	CLRND 5	161.0	560001	NODAWAYCO	161.0	1	153	146.4	146.7	3.8%	S1280 to Humboldt	XS642069>642073>\$1
635034	CLRND 5	161.0	560001	NODAWAYCO	161.0	1	153	146.4	146.7	3.8%	S1280 to Humboldt	XS642070>642072>\$1
635034	CLRND 5	161.0	560001	NODAWAYCO	161.0	1	153	146.4	146.7	3.8%	S1280 to Humboldt	XS642070>642073>\$1
635034	CLRND 5	161.0	560001	NODAWAYCO	161.0	1	153	146.4	146.7	3.8%	S1280 to Humboldt	XS640265>640370>\$1
635034	CLRND 5	161.0	560001	NODAWAYCO	161.0	1	153	146.4	146.7	3.8%	S1280 to Humboldt	XS640184>640302>\$1
635034	CLRND 5	161.0	560001	NODAWAYCO	161.0	1	153	146.4	146.7	3.8%	S1280 to Humboldt	XS640265>640287>\$1
635034	CLRND 5	161.0	560001	NODAWAYCO	161.0	1	153	146.4	146.7	3.8%	S1280 to Humboldt	XS640269>640270>\$1
635034	CLRND 5	161.0	560001	NODAWAYCO	161.0	1	153	146.4	146.7	3.8%	S1280 to Humboldt	XS642068>642069>\$1
635034	CLRND 5	161.0	560001	NODAWAYCO	161.0	1	153	146.4	146.7	3.8%	S1280 to Humboldt	XS640224>640225>\$1
635034	CLRND 5	161.0	560001	NODAWAYCO	161.0	1	153	146.4	146.7	3.8%	S1280 to Humboldt	XS640261>640275>\$1
635034	CLRND 5	161.0	560001	NODAWAYCO	161.0	1	153	146.5	146.7	3.8%	S1280 to Humboldt	XS640259>640353>\$1
635034	CLRND 5	161.0	560001	NODAWAYCO	161.0	1	153	146.4	146.7	3.8%	S1280 to Humboldt	XS640224>640242>\$1
635034	CLRND 5	161.0	560001	NODAWAYCO	161.0	1	153	146.4	146.7	3.8%	S1280 to Humboldt	XS640224>640225>\$2
635034	CLRND 5	161.0	560001	NODAWAYCO	161.0	1	153	146.4	146.7	3.8%	S1280 to Humboldt	XS640256>640331>\$1
635034	CLRND 5	161.0	560001	NODAWAYCO	161.0	1	153	146.4	146.7	3.8%	S1280 to Humboldt	XS640263>640298>\$1
635034	CLRND 5	161.0	560001	NODAWAYCO	161.0	1	153	146.4	146.7	3.8%	S1280 to Humboldt	XS641087>641088>\$1
635034	CLRND 5	161.0	560001	NODAWAYCO	161.0	1	153	146.4	146.7	3.8%	S1280 to Humboldt	XS645030>645033>\$1
635034	CLRND 5	161.0	560001	NODAWAYCO	161.0	1	153	146.4	146.7	3.8%	S1280 to Humboldt	XS640275>640276>\$2

635034	CLRNDA 5	161.0	560001	NODAWAYCO	161.0	1	153	146.4	146.7	3.8%	S1280 to Humboldt	XS640220>640368>\$1
635034	CLRNDA 5	161.0	560001	NODAWAYCO	161.0	1	153	146.4	146.7	3.8%	S1280 to Humboldt	XS640250>640251>\$2
635034	CLRNDA 5	161.0	560001	NODAWAYCO	161.0	1	153	146.4	146.7	3.8%	S1280 to Humboldt	XS640275>640276>\$1
635034	CLRNDA 5	161.0	560001	NODAWAYCO	161.0	1	153	146.4	146.7	3.8%	S1280 to Humboldt	XS641087>641090>\$1
635034	CLRNDA 5	161.0	560001	NODAWAYCO	161.0	1	153	146.4	146.7	3.8%	S1280 to Humboldt	XS640252>640253>640254\$1
635034	CLRNDA 5	161.0	560001	NODAWAYCO	161.0	1	153	146.4	146.7	3.8%	S1280 to Humboldt	XS642066>642064>\$1
635034	CLRNDA 5	161.0	560001	NODAWAYCO	161.0	1	153	146.4	146.7	3.8%	S1280 to Humboldt	XS645031>647006>\$1
635034	CLRNDA 5	161.0	560001	NODAWAYCO	161.0	1	153	146.4	146.7	3.8%	S1280 to Humboldt	XS640250>640261>\$1
635034	CLRNDA 5	161.0	560001	NODAWAYCO	161.0	1	153	146.4	146.7	3.8%	S1280 to Humboldt	XS642066>642065>\$1
635034	CLRNDA 5	161.0	560001	NODAWAYCO	161.0	1	153	146.4	146.7	3.8%	S1280 to Humboldt	XS642066>642071>\$1
635034	CLRNDA 5	161.0	560001	NODAWAYCO	161.0	1	153	146.4	146.7	3.8%	S1280 to Humboldt	XS640271>640272>640274\$1
635034	CLRNDA 5	161.0	560001	NODAWAYCO	161.0	1	153	146.4	146.7	3.8%	S1280 to Humboldt	XS640269>640326>\$2
635034	CLRNDA 5	161.0	560001	NODAWAYCO	161.0	1	153	146.4	146.7	3.8%	S1280 to Humboldt	XS642066>642072>\$1
635034	CLRNDA 5	161.0	560001	NODAWAYCO	161.0	1	153	146.4	146.7	3.8%	S1280 to Humboldt	XS640269>640326>\$1
635034	CLRNDA 5	161.0	560001	NODAWAYCO	161.0	1	153	146.4	146.7	3.8%	S1280 to Humboldt	XS642066>642074>\$1
635034	CLRNDA 5	161.0	560001	NODAWAYCO	161.0	1	153	146.4	146.7	3.8%	S1280 to Humboldt	XS640250>640383>\$1
635034	CLRNDA 5	161.0	560001	NODAWAYCO	161.0	1	153	146.4	146.7	3.8%	S1280 to Humboldt	XS642066>642075>\$1
635034	CLRNDA 5	161.0	560001	NODAWAYCO	161.0	1	153	146.4	146.7	3.8%	S1280 to Humboldt	XS640269>640270>\$2
635034	CLRNDA 5	161.0	560001	NODAWAYCO	161.0	1	153	146.5	146.7	3.8%	S1280 to Humboldt	XS640192>659152>\$1
635034	CLRNDA 5	161.0	560001	NODAWAYCO	161.0	1	153	146.4	146.7	3.8%	S1280 to Humboldt	XS640328>640340>\$1
635034	CLRNDA 5	161.0	560001	NODAWAYCO	161.0	1	153	146.4	146.7	3.8%	S1280 to Humboldt	XS640336>640337>\$1
635034	CLRNDA 5	161.0	560001	NODAWAYCO	161.0	1	153	146.4	146.7	3.8%	S1280 to Humboldt	XS640331>640383>\$1
635034	CLRNDA 5	161.0	560001	NODAWAYCO	161.0	1	153	146.4	146.7	3.8%	S1280 to Humboldt	XS640183>640184>643066\$2
635034	CLRNDA 5	161.0	560001	NODAWAYCO	161.0	1	153	146.4	146.7	3.8%	S1280 to Humboldt	XS640370>659186>\$1
635034	CLRNDA 5	161.0	560001	NODAWAYCO	161.0	1	153	146.4	146.7	3.8%	S1280 to Humboldt	XS640330>640331>643128\$1
635034	CLRNDA 5	161.0	560001	NODAWAYCO	161.0	1	153	146.4	146.7	3.8%	S1280 to Humboldt	XS640336>640337>\$2
635034	CLRNDA 5	161.0	560001	NODAWAYCO	161.0	1	153	146.4	146.7	3.8%	S1280 to Humboldt	XS645116>646258>\$1

635034	CLRND 5	161.0	560001	NODAWAYCO	161.0	1	153	146.4	146.7	3.8%	S1280 to Humboldt	XS640210>640392>\$1
635034	CLRND 5	161.0	560001	NODAWAYCO	161.0	1	153	146.4	146.7	3.8%	S1280 to Humboldt	XS640210>640351>\$1
635034	CLRND 5	161.0	560001	NODAWAYCO	161.0	1	153	146.4	146.7	3.8%	S1280 to Humboldt	XS640375>640411>\$1
635034	CLRND 5	161.0	560001	NODAWAYCO	161.0	1	153	146.4	146.7	3.8%	S1280 to Humboldt	XS640372>641087>\$1
635034	CLRND 5	161.0	560001	NODAWAYCO	161.0	1	153	146.4	146.7	3.8%	S1280 to Humboldt	XS640326>640365>\$1
635034	CLRND 5	161.0	560001	NODAWAYCO	161.0	1	153	146.4	146.7	3.8%	S1280 to Humboldt	XS640340>640375>\$1
635034	CLRND 5	161.0	560001	NODAWAYCO	161.0	1	153	146.4	146.7	3.8%	S1280 to Humboldt	XS640347>640348>643169\$2
635034	CLRND 5	161.0	560001	NODAWAYCO	161.0	1	153	146.4	146.7	3.8%	S1280 to Humboldt	XS640228>640229>\$1
635034	CLRND 5	161.0	560001	NODAWAYCO	161.0	1	153	146.4	146.7	3.8%	S1280 to Humboldt	XS640347>640348>643139\$1
635034	CLRND 5	161.0	560001	NODAWAYCO	161.0	1	153	146.4	146.7	3.8%	S1280 to Humboldt	XS640183>640184>640185\$1
635034	CLRND 5	161.0	560001	NODAWAYCO	161.0	1	153	146.4	146.7	3.8%	S1280 to Humboldt	XS640345>640346>\$2
635034	CLRND 5	161.0	560001	NODAWAYCO	161.0	1	153	146.4	146.7	3.8%	S1280 to Humboldt	XS640345>640346>\$1
635034	CLRND 5	161.0	560001	NODAWAYCO	161.0	1	153	146.4	146.7	3.8%	S1280 to Humboldt	XS640228>640229>\$2
635034	CLRND 5	161.0	560001	NODAWAYCO	161.0	1	153	146.4	146.7	3.8%	S1280 to Humboldt	XS640351>652482>\$1
635034	CLRND 5	161.0	560001	NODAWAYCO	161.0	1	153	146.4	146.7	3.8%	S1280 to Humboldt	XS640201>642071>\$1
635034	CLRND 5	161.0	560001	NODAWAYCO	161.0	1	153	146.4	146.7	3.8%	S1280 to Humboldt	XS640227>640386>\$1
635034	CLRND 5	161.0	560001	NODAWAYCO	161.0	1	153	146.5	146.7	3.8%	S1280 to Humboldt	XS640362>647974>\$1
635034	CLRND 5	161.0	560001	NODAWAYCO	161.0	1	153	146.4	146.7	3.8%	S1280 to Humboldt	XS640361>647966>\$1
635034	CLRND 5	161.0	560001	NODAWAYCO	161.0	1	153	146.4	146.7	3.8%	S1280 to Humboldt	XS640206>640368>\$1
635034	CLRND 5	161.0	560001	NODAWAYCO	161.0	1	153	146.4	146.7	3.8%	S1280 to Humboldt	XS640228>640298>\$1
635034	CLRND 5	161.0	560001	NODAWAYCO	161.0	1	153	146.4	146.7	3.8%	S1280 to Humboldt	XS640357>640363>\$1
635034	CLRND 5	161.0	560001	NODAWAYCO	161.0	1	153	146.4	146.7	3.8%	S1280 to Humboldt	XS640340>640341>\$1
635034	CLRND 5	161.0	560001	NODAWAYCO	161.0	1	153	146.4	146.7	3.8%	S1280 to Humboldt	XS640201>642072>\$1
635034	CLRND 5	161.0	560001	NODAWAYCO	161.0	1	153	146.4	146.7	3.8%	S1280 to Humboldt	XS645451>645459>\$1
635034	CLRND 5	161.0	560001	NODAWAYCO	161.0	1	153	146.4	146.7	3.8%	S1280 to Humboldt	XS640228>640296>\$1
635034	CLRND 5	161.0	560001	NODAWAYCO	161.0	1	153	146.5	146.7	3.8%	S1280 to Humboldt	XS640338>659242>\$1
635034	CLRND 5	161.0	560001	NODAWAYCO	161.0	1	153	146.4	146.7	3.8%	S1280 to Humboldt	XS640386>640387>643156\$2

635034	CLRNDA 5	161.0	560001	NODAWAYCO	161.0	1	153	146.4	146.7	3.8%	S1280 to Humboldt	XS640387>640388>\$1
635034	CLRNDA 5	161.0	560001	NODAWAYCO	161.0	1	153	146.4	146.7	3.8%	S1280 to Humboldt	XS640200>652571>652316\$2
635034	CLRNDA 5	161.0	560001	NODAWAYCO	161.0	1	153	146.4	146.7	3.8%	S1280 to Humboldt	XS640387>640424>\$1
635034	CLRNDA 5	161.0	560001	NODAWAYCO	161.0	1	153	146.4	146.7	3.8%	S1280 to Humboldt	XS640305>640306>\$1
635034	CLRNDA 5	161.0	560001	NODAWAYCO	161.0	1	153	146.4	146.7	3.8%	S1280 to Humboldt	XS640200>652571>643071\$3
635034	CLRNDA 5	161.0	560001	NODAWAYCO	161.0	1	153	146.4	146.7	3.8%	S1280 to Humboldt	XS640386>640387>643155\$1
635034	CLRNDA 5	161.0	560001	NODAWAYCO	161.0	1	153	146.4	146.7	3.8%	S1280 to Humboldt	XS640305>640306>\$2
635034	CLRNDA 5	161.0	560001	NODAWAYCO	161.0	1	153	146.4	146.7	3.8%	S1280 to Humboldt	XS640387>640424>\$2
635034	CLRNDA 5	161.0	560001	NODAWAYCO	161.0	1	153	146.4	146.7	3.8%	S1280 to Humboldt	XS640238>640240>\$1
635034	CLRNDA 5	161.0	560001	NODAWAYCO	161.0	1	153	146.4	146.7	3.8%	S1280 to Humboldt	XS640387>640388>\$2
635034	CLRNDA 5	161.0	560001	NODAWAYCO	161.0	1	153	146.5	146.7	3.8%	S1280 to Humboldt	XS640238>640013>\$1
635034	CLRNDA 5	161.0	560001	NODAWAYCO	161.0	1	153	146.5	146.7	3.8%	S1280 to Humboldt	XS640305>640349>\$1
635034	CLRNDA 5	161.0	560001	NODAWAYCO	161.0	1	153	146.4	146.7	3.8%	S1280 to Humboldt	XS645113>646258>\$1
635034	CLRNDA 5	161.0	560001	NODAWAYCO	161.0	1	153	146.4	146.7	3.8%	S1280 to Humboldt	XS640227>640228>643083\$1
635034	CLRNDA 5	161.0	560001	NODAWAYCO	161.0	1	153	146.4	146.7	3.8%	S1280 to Humboldt	XS640214>641088>643075\$1
635034	CLRNDA 5	161.0	560001	NODAWAYCO	161.0	1	153	146.4	146.7	3.8%	S1280 to Humboldt	XS640200>652571>652314\$1
635034	CLRNDA 5	161.0	560001	NODAWAYCO	161.0	1	153	146.4	146.7	3.8%	S1280 to Humboldt	XS645115>646258>\$1
635034	CLRNDA 5	161.0	560001	NODAWAYCO	161.0	1	153	146.4	146.7	3.8%	S1280 to Humboldt	XS645114>646258>\$1
635034	CLRNDA 5	161.0	560001	NODAWAYCO	161.0	1	153	146.5	146.7	3.8%	S1280 to Humboldt	XS640238>640287>\$1
635034	CLRNDA 5	161.0	560001	NODAWAYCO	161.0	1	153	146.4	146.7	3.8%	S1280 to Humboldt	XS640300>640409>\$1
635034	CLRNDA 5	161.0	560001	NODAWAYCO	161.0	1	153	146.4	146.7	3.8%	S1280 to Humboldt	XS640215>640216>\$1
635034	CLRNDA 5	161.0	560001	NODAWAYCO	161.0	1	153	146.4	146.7	3.8%	S1280 to Humboldt	XS647424>647425>\$1
635034	CLRNDA 5	161.0	560001	NODAWAYCO	161.0	1	153	146.4	146.7	3.8%	S1280 to Humboldt	XS647006>647938>\$1
635034	CLRNDA 5	161.0	560001	NODAWAYCO	161.0	1	153	146.4	146.7	3.8%	S1280 to Humboldt	XS647425>647426>\$1
635034	CLRNDA 5	161.0	560001	NODAWAYCO	161.0	1	153	146.4	146.7	3.8%	S1280 to Humboldt	XS647846>647983>\$1
635034	CLRNDA 5	161.0	560001	NODAWAYCO	161.0	1	153	146.4	146.7	3.8%	S1280 to Humboldt	XS647006>647916>\$1
635034	CLRNDA 5	161.0	560001	NODAWAYCO	161.0	1	153	146.4	146.7	3.8%	S1280 to Humboldt	XS650238>650270>\$1

635034	CLRNDA 5	161.0	560001	NODAWAYCO	161.0	1	153	146.4	146.7	3.8%	S1280 to Humboldt	XS647421>647426>\$1
635034	CLRNDA 5	161.0	560001	NODAWAYCO	161.0	1	153	146.5	146.7	3.8%	S1280 to Humboldt	XS646221>646231>\$1
635034	CLRNDA 5	161.0	560001	NODAWAYCO	161.0	1	153	146.4	146.7	3.8%	S1280 to Humboldt	XS647015>647017>\$1
635034	CLRNDA 5	161.0	560001	NODAWAYCO	161.0	1	153	146.4	146.7	3.8%	S1280 to Humboldt	XS647423>647424>\$1
635034	CLRNDA 5	161.0	560001	NODAWAYCO	161.0	1	153	146.4	146.7	3.8%	S1280 to Humboldt	XS647421>647422>\$1
635034	CLRNDA 5	161.0	560001	NODAWAYCO	161.0	1	153	146.4	146.7	3.8%	S1280 to Humboldt	XS647423>647427>\$1
635034	CLRNDA 5	161.0	560001	NODAWAYCO	161.0	1	153	146.4	146.7	3.8%	S1280 to Humboldt	XS650250>650255>\$1
635034	CLRNDA 5	161.0	560001	NODAWAYCO	161.0	1	153	146.4	146.7	3.8%	S1280 to Humboldt	XS647421>647427>\$1
635034	CLRNDA 5	161.0	560001	NODAWAYCO	161.0	1	153	146.4	146.7	3.8%	S1280 to Humboldt	XS647422>647424>\$1
635034	CLRNDA 5	161.0	560001	NODAWAYCO	161.0	1	153	146.5	146.7	3.8%	S1280 to Humboldt	XS647014>647914>\$1
635034	CLRNDA 5	161.0	560001	NODAWAYCO	161.0	1	153	146.4	146.7	3.8%	S1280 to Humboldt	XS650242>650290>\$1
635034	CLRNDA 5	161.0	560001	NODAWAYCO	161.0	1	153	146.4	146.7	3.8%	S1280 to Humboldt	XS650238>650258>\$1
635034	CLRNDA 5	161.0	560001	NODAWAYCO	161.0	1	153	146.4	146.7	3.8%	S1280 to Humboldt	XS650230>650238>\$1
635034	CLRNDA 5	161.0	560001	NODAWAYCO	161.0	1	153	146.4	146.7	3.8%	S1280 to Humboldt	XS650233>650240>\$1
635034	CLRNDA 5	161.0	560001	NODAWAYCO	161.0	1	153	146.4	146.7	3.8%	S1280 to Humboldt	XS646305>646341>\$1
635034	CLRNDA 5	161.0	560001	NODAWAYCO	161.0	1	153	146.4	146.7	3.8%	S1280 to Humboldt	XS650275>650283>\$1
635034	CLRNDA 5	161.0	560001	NODAWAYCO	161.0	1	153	146.5	146.7	3.8%	S1280 to Humboldt	XS647906>647924>\$1
635034	CLRNDA 5	161.0	560001	NODAWAYCO	161.0	1	153	146.4	146.7	3.8%	S1280 to Humboldt	XS650283>650285>\$1
635034	CLRNDA 5	161.0	560001	NODAWAYCO	161.0	1	153	146.4	146.7	3.8%	S1280 to Humboldt	XS647906>647938>\$1
635034	CLRNDA 5	161.0	560001	NODAWAYCO	161.0	1	153	146.4	146.7	3.8%	S1280 to Humboldt	XS646298>646305>\$1
635034	CLRNDA 5	161.0	560001	NODAWAYCO	161.0	1	153	146.4	146.7	3.8%	S1280 to Humboldt	XS650229>650250>\$1
635034	CLRNDA 5	161.0	560001	NODAWAYCO	161.0	1	153	146.4	146.7	3.8%	S1280 to Humboldt	XS647900>647914>\$1
635034	CLRNDA 5	161.0	560001	NODAWAYCO	161.0	1	153	146.4	146.7	3.8%	S1280 to Humboldt	XS647900>647985>\$1
635034	CLRNDA 5	161.0	560001	NODAWAYCO	161.0	1	153	146.4	146.7	3.8%	S1280 to Humboldt	XS647006>647017>\$1
635034	CLRNDA 5	161.0	560001	NODAWAYCO	161.0	1	153	146.4	146.7	3.8%	S1280 to Humboldt	XS647902>647983>\$1
635034	CLRNDA 5	161.0	560001	NODAWAYCO	161.0	1	153	146.4	146.7	3.8%	S1280 to Humboldt	XS650256>650260>\$1
635034	CLRNDA 5	161.0	560001	NODAWAYCO	161.0	1	153	146.4	146.7	3.8%	S1280 to Humboldt	XS650233>650259>\$1

635034	CLRND 5	161.0	560001	NODAWAYCO	161.0	1	153	146.4	146.7	3.8%	S1280 to Humboldt	XS647416>647421>\$1
635034	CLRND 5	161.0	560001	NODAWAYCO	161.0	1	153	146.4	146.7	3.8%	S1280 to Humboldt	XS647091>647984>\$1
635034	CLRND 5	161.0	560001	NODAWAYCO	161.0	1	153	146.4	146.7	3.8%	S1280 to Humboldt	XS647107>647994>\$1
635034	CLRND 5	161.0	560001	NODAWAYCO	161.0	1	153	146.4	146.7	3.8%	S1280 to Humboldt	XS647091>647427>\$1
635034	CLRND 5	161.0	560001	NODAWAYCO	161.0	1	153	146.4	146.7	3.8%	S1280 to Humboldt	XS650255>650274>\$1
635034	CLRND 5	161.0	560001	NODAWAYCO	161.0	1	153	146.4	146.7	3.8%	S1280 to Humboldt	XS647105>647910>\$1
635034	CLRND 5	161.0	560001	NODAWAYCO	161.0	1	153	146.4	146.7	3.8%	S1280 to Humboldt	XS646226>646237>\$1
635034	CLRND 5	161.0	560001	NODAWAYCO	161.0	1	153	146.4	146.7	3.8%	S1280 to Humboldt	XS647108>647994>\$1
635034	CLRND 5	161.0	560001	NODAWAYCO	161.0	1	153	146.4	146.7	3.8%	S1280 to Humboldt	XS650270>650271>\$1
635034	CLRND 5	161.0	560001	NODAWAYCO	161.0	1	153	146.4	146.7	3.8%	S1280 to Humboldt	XS650260>650262>\$1
635034	CLRND 5	161.0	560001	NODAWAYCO	161.0	1	153	146.5	146.7	3.8%	S1280 to Humboldt	XS647090>647982>\$1
635034	CLRND 5	161.0	560001	NODAWAYCO	161.0	1	153	146.4	146.7	3.8%	S1280 to Humboldt	XS650267>650285>\$1
635034	CLRND 5	161.0	560001	NODAWAYCO	161.0	1	153	146.4	146.7	3.8%	S1280 to Humboldt	XS647102>647103>\$1
635034	CLRND 5	161.0	560001	NODAWAYCO	161.0	1	153	146.4	146.7	3.8%	S1280 to Humboldt	XS646226>646298>\$1
635034	CLRND 5	161.0	560001	NODAWAYCO	161.0	1	153	146.4	146.7	3.8%	S1280 to Humboldt	XS650267>650273>\$1
635034	CLRND 5	161.0	560001	NODAWAYCO	161.0	1	153	146.4	146.7	3.8%	S1280 to Humboldt	XS650267>650272>\$1
635034	CLRND 5	161.0	560001	NODAWAYCO	161.0	1	153	146.4	146.7	3.8%	S1280 to Humboldt	XS650267>650367>\$1
635034	CLRND 5	161.0	560001	NODAWAYCO	161.0	1	153	146.4	146.7	3.8%	S1280 to Humboldt	XS647104>647939>\$1
635034	CLRND 5	161.0	560001	NODAWAYCO	161.0	1	153	146.4	146.7	3.8%	S1280 to Humboldt	XS646226>646252>\$1
635034	CLRND 5	161.0	560001	NODAWAYCO	161.0	1	153	146.4	146.7	3.8%	S1280 to Humboldt	XS646226>646298>\$2
635034	CLRND 5	161.0	560001	NODAWAYCO	161.0	1	153	146.4	146.7	3.8%	S1280 to Humboldt	XS647105>647901>\$1
635034	CLRND 5	161.0	560001	NODAWAYCO	161.0	1	153	146.4	146.7	3.8%	S1280 to Humboldt	XS650267>650367>\$2
635034	CLRND 5	161.0	560001	NODAWAYCO	161.0	1	153	146.5	146.7	3.8%	S1280 to Humboldt	XS647111>647967>\$1
635034	CLRND 5	161.0	560001	NODAWAYCO	161.0	1	153	146.4	146.7	3.8%	S1280 to Humboldt	XS647017>647108>\$1
635034	CLRND 5	161.0	560001	NODAWAYCO	161.0	1	153	146.4	146.7	3.8%	S1280 to Humboldt	XS647972>647982>\$1
635034	CLRND 5	161.0	560001	NODAWAYCO	161.0	1	153	146.4	146.7	3.8%	S1280 to Humboldt	XS650271>650274>\$1
635034	CLRND 5	161.0	560001	NODAWAYCO	161.0	1	153	146.4	146.7	3.8%	S1280 to Humboldt	XS650256>650257>\$1

635034	CLRND 5	161.0	560001	NODAWAYCO	161.0	1	153	146.4	146.7	3.8%	S1280 to Humboldt	XS647016>647906>\$1
635034	CLRND 5	161.0	560001	NODAWAYCO	161.0	1	153	146.4	146.7	3.8%	S1280 to Humboldt	XS647411>647427>\$1
635034	CLRND 5	161.0	560001	NODAWAYCO	161.0	1	153	146.4	146.7	3.8%	S1280 to Humboldt	XS647016>647107>\$1
635034	CLRND 5	161.0	560001	NODAWAYCO	161.0	1	153	146.4	146.7	3.8%	S1280 to Humboldt	XS647908>647910>\$1
635034	CLRND 5	161.0	560001	NODAWAYCO	161.0	1	153	146.4	146.7	3.8%	S1280 to Humboldt	XS646201>646206>\$1
635034	CLRND 5	161.0	560001	NODAWAYCO	161.0	1	153	146.4	146.7	3.8%	S1280 to Humboldt	XS647112>647113>\$1
635034	CLRND 5	161.0	560001	NODAWAYCO	161.0	1	153	146.4	146.7	3.8%	S1280 to Humboldt	XS650259>650262>\$1
635034	CLRND 5	161.0	560001	NODAWAYCO	161.0	1	153	146.5	146.7	3.8%	S1280 to Humboldt	XS647090>647971>\$1
635034	CLRND 5	161.0	560001	NODAWAYCO	161.0	1	153	146.4	146.7	3.8%	S1280 to Humboldt	XS650270>650273>\$1
635034	CLRND 5	161.0	560001	NODAWAYCO	161.0	1	153	146.4	146.7	3.8%	S1280 to Humboldt	XS650270>650272>\$1
635034	CLRND 5	161.0	560001	NODAWAYCO	161.0	1	153	146.4	146.7	3.8%	S1280 to Humboldt	XS650257>650270>\$1
635034	CLRND 5	161.0	560001	NODAWAYCO	161.0	1	153	146.4	146.7	3.8%	S1280 to Humboldt	XS647114>647962>\$1
635034	CLRND 5	161.0	560001	NODAWAYCO	161.0	1	153	146.4	146.7	3.8%	S1280 to Humboldt	XS650257>650258>\$1
635034	CLRND 5	161.0	560001	NODAWAYCO	161.0	1	153	146.4	146.7	3.8%	S1280 to Humboldt	XS647114>647971>\$1
635034	CLRND 5	161.0	560001	NODAWAYCO	161.0	1	153	146.4	146.7	3.8%	S1280 to Humboldt	XS647938>647995>\$1
635034	CLRND 5	161.0	560001	NODAWAYCO	161.0	1	153	146.4	146.7	3.8%	S1280 to Humboldt	XS646210>647910>648210\$1
635034	CLRND 5	161.0	560001	NODAWAYCO	161.0	1	153	146.4	146.7	3.8%	S1280 to Humboldt	XS650215>650226>\$1
635034	CLRND 5	161.0	560001	NODAWAYCO	161.0	1	153	146.4	146.7	3.8%	S1280 to Humboldt	XS646251>646341>\$1
635034	CLRND 5	161.0	560001	NODAWAYCO	161.0	1	153	146.4	146.7	3.8%	S1280 to Humboldt	XS647930>647939>\$1
635034	CLRND 5	161.0	560001	NODAWAYCO	161.0	1	153	146.4	146.7	3.8%	S1280 to Humboldt	XS646235>646253>\$1
635034	CLRND 5	161.0	560001	NODAWAYCO	161.0	1	153	146.5	146.7	3.8%	S1280 to Humboldt	XS652312>659197>\$1
635034	CLRND 5	161.0	560001	NODAWAYCO	161.0	1	153	146.4	146.7	3.8%	S1280 to Humboldt	XS650215>650228>\$1
635034	CLRND 5	161.0	560001	NODAWAYCO	161.0	1	153	146.4	146.7	3.8%	S1280 to Humboldt	XS650214>650226>\$1
635034	CLRND 5	161.0	560001	NODAWAYCO	161.0	1	153	146.4	146.7	3.8%	S1280 to Humboldt	XS646251>646298>\$1
635034	CLRND 5	161.0	560001	NODAWAYCO	161.0	1	153	146.4	146.7	3.8%	S1280 to Humboldt	XS647961>640320>\$1
635034	CLRND 5	161.0	560001	NODAWAYCO	161.0	1	153	146.4	146.7	3.8%	S1280 to Humboldt	XS647916>647940>\$1
635034	CLRND 5	161.0	560001	NODAWAYCO	161.0	1	153	146.4	146.7	3.8%	S1280 to Humboldt	XS650214>650290>\$1

635034	CLRND 5	161.0	560001	NODAWAYCO	161.0	1	153	146.4	146.7	3.8%	S1280 to Humboldt	XS650217>650230>\$1
635034	CLRND 5	161.0	560001	NODAWAYCO	161.0	1	153	146.4	146.7	3.8%	S1280 to Humboldt	XS647917>647918>\$1
635034	CLRND 5	161.0	560001	NODAWAYCO	161.0	1	153	146.4	146.7	3.8%	S1280 to Humboldt	XS650217>650219>\$1
635034	CLRND 5	161.0	560001	NODAWAYCO	161.0	1	153	146.4	146.7	3.8%	S1280 to Humboldt	XS647918>647930>\$1
635034	CLRND 5	161.0	560001	NODAWAYCO	161.0	1	153	146.4	146.7	3.8%	S1280 to Humboldt	XS652300>659238>\$1
635034	CLRND 5	161.0	560001	NODAWAYCO	161.0	1	153	146.5	146.7	3.8%	S1280 to Humboldt	XS646255>646259>\$1
635034	CLRND 5	161.0	560001	NODAWAYCO	161.0	1	153	146.5	146.7	3.8%	S1280 to Humboldt	XS647921>647942>\$1
635034	CLRND 5	161.0	560001	NODAWAYCO	161.0	1	153	146.5	146.7	3.8%	S1280 to Humboldt	XS650214>650216>\$1
635034	CLRND 5	161.0	560001	NODAWAYCO	161.0	1	153	146.4	146.7	3.8%	S1280 to Humboldt	XS647994>647995>\$1
635034	CLRND 5	161.0	560001	NODAWAYCO	161.0	1	153	146.5	146.7	3.8%	S1280 to Humboldt	XS646210>646217>\$1
635034	CLRND 5	161.0	560001	NODAWAYCO	161.0	1	153	146.4	146.7	3.8%	S1280 to Humboldt	XS650208>650212>\$1
635034	CLRND 5	161.0	560001	NODAWAYCO	161.0	1	153	146.4	146.7	3.8%	S1280 to Humboldt	XS650185>650285>650485\$2
635034	CLRND 5	161.0	560001	NODAWAYCO	161.0	1	153	146.4	146.7	3.8%	S1280 to Humboldt	XS646237>646345>\$1
635034	CLRND 5	161.0	560001	NODAWAYCO	161.0	1	153	146.4	146.7	3.8%	S1280 to Humboldt	XS650185>650285>650385\$1
635034	CLRND 5	161.0	560001	NODAWAYCO	161.0	1	153	146.4	146.7	3.8%	S1280 to Humboldt	XS652398>652523>\$1
635034	CLRND 5	161.0	560001	NODAWAYCO	161.0	1	153	146.4	146.7	3.8%	S1280 to Humboldt	XS646237>646253>\$1
635034	CLRND 5	161.0	560001	NODAWAYCO	161.0	1	153	146.4	146.7	3.8%	S1280 to Humboldt	XS652398>652399>\$1
635034	CLRND 5	161.0	560001	NODAWAYCO	161.0	1	153	146.5	146.7	3.8%	S1280 to Humboldt	XS652312>659242>\$1
635034	CLRND 5	161.0	560001	NODAWAYCO	161.0	1	153	146.4	146.7	3.8%	S1280 to Humboldt	XS647965>647975>\$1
635034	CLRND 5	161.0	560001	NODAWAYCO	161.0	1	153	146.4	146.7	3.8%	S1280 to Humboldt	XS650208>650308>\$3
635034	CLRND 5	161.0	560001	NODAWAYCO	161.0	1	153	146.4	146.7	3.8%	S1280 to Humboldt	XS647928>647942>\$1
635034	CLRND 5	161.0	560001	NODAWAYCO	161.0	1	153	146.4	146.7	3.8%	S1280 to Humboldt	XS650208>650308>\$2
635034	CLRND 5	161.0	560001	NODAWAYCO	161.0	1	153	146.4	146.7	3.8%	S1280 to Humboldt	XS646236>646345>\$1
635034	CLRND 5	161.0	560001	NODAWAYCO	161.0	1	153	146.4	146.7	3.8%	S1280 to Humboldt	XS650208>650230>\$1
635034	CLRND 5	161.0	560001	NODAWAYCO	161.0	1	153	146.5	146.7	3.8%	S1280 to Humboldt	XS647967>647968>\$1
635034	CLRND 5	161.0	560001	NODAWAYCO	161.0	1	153	146.4	146.7	3.8%	S1280 to Humboldt	XS647912>647923>\$1
635034	CLRND 5	161.0	560001	NODAWAYCO	161.0	1	153	146.4	146.7	3.8%	S1280 to Humboldt	XS647908>647913>\$1

635034	CLRNDA 5	161.0	560001	NODAWAYCO	161.0	1	153	146.4	146.7	3.8%	S1280 to Humboldt	XS650228>650233>\$1
635034	CLRNDA 5	161.0	560001	NODAWAYCO	161.0	1	153	146.4	146.7	3.8%	S1280 to Humboldt	XS647909>647918>\$1
635034	CLRNDA 5	161.0	560001	NODAWAYCO	161.0	1	153	146.4	146.7	3.8%	S1280 to Humboldt	XS652294>652538>\$1
635034	CLRNDA 5	161.0	560001	NODAWAYCO	161.0	1	153	146.4	146.7	3.8%	S1280 to Humboldt	XS647912>647924>\$1
635034	CLRNDA 5	161.0	560001	NODAWAYCO	161.0	1	153	146.4	146.7	3.8%	S1280 to Humboldt	XS650219>650240>\$1
635034	CLRNDA 5	161.0	560001	NODAWAYCO	161.0	1	153	146.4	146.7	3.8%	S1280 to Humboldt	XS650218>650230>\$1
635034	CLRNDA 5	161.0	560001	NODAWAYCO	161.0	1	153	146.4	146.7	3.8%	S1280 to Humboldt	XS652294>652295>\$1
635034	CLRNDA 5	161.0	560001	NODAWAYCO	161.0	1	153	146.4	146.7	3.8%	S1280 to Humboldt	XS650218>650238>\$1
635034	CLRNDA 5	161.0	560001	NODAWAYCO	161.0	1	153	146.4	146.7	3.8%	S1280 to Humboldt	XS647911>647913>\$1
635034	CLRNDA 5	161.0	560001	NODAWAYCO	161.0	1	153	146.4	146.7	3.8%	S1280 to Humboldt	XS647910>647923>\$1
635034	CLRNDA 5	161.0	560001	NODAWAYCO	161.0	1	153	146.4	146.7	3.8%	S1280 to Humboldt	XS647909>647921>\$1
635034	CLRNDA 5	161.0	560001	NODAWAYCO	161.0	1	153	146.5	146.7	3.8%	S1280 to Humboldt	XS646263>647111>648263\$1
635034	CLRNDA 5	161.0	560001	NODAWAYCO	161.0	1	153	146.4	146.7	3.8%	S1280 to Humboldt	XS650290>650093>\$1
635034	CLRNDA 5	161.0	560001	NODAWAYCO	161.0	1	153	146.4	146.7	3.8%	S1280 to Humboldt	XS647916>647917>\$1
635034	CLRNDA 5	161.0	560001	NODAWAYCO	161.0	1	153	146.4	146.7	3.8%	S1280 to Humboldt	XS650290>650091>\$1
635034	CLRNDA 5	161.0	560001	NODAWAYCO	161.0	1	153	146.4	146.7	3.8%	S1280 to Humboldt	XS300074>301149>\$1
635034	CLRNDA 5	161.0	560001	NODAWAYCO	161.0	1	153	146.4	146.7	3.8%	S1280 to Humboldt	XS300084>505438>\$1
635034	CLRNDA 5	161.0	560001	NODAWAYCO	161.0	1	153	146.4	146.7	3.8%	S1280 to Humboldt	XS300065>301059>\$1
635034	CLRNDA 5	161.0	560001	NODAWAYCO	161.0	1	153	146.4	146.7	3.8%	S1280 to Humboldt	XS300064>301044>\$1
635034	CLRNDA 5	161.0	560001	NODAWAYCO	161.0	1	153	146.4	146.7	3.8%	S1280 to Humboldt	XS300092>301065>\$1
635034	CLRNDA 5	161.0	560001	NODAWAYCO	161.0	1	153	146.4	146.7	3.8%	S1280 to Humboldt	XS300043>300090>\$1
635034	CLRNDA 5	161.0	560001	NODAWAYCO	161.0	1	153	146.5	146.7	3.8%	S1280 to Humboldt	NCU GEN OFF
635034	CLRNDA 5	161.0	560001	NODAWAYCO	161.0	1	153	146.4	146.7	3.8%	S1280 to Humboldt	XS300089>300673>\$2
635034	CLRNDA 5	161.0	560001	NODAWAYCO	161.0	1	153	146.4	146.7	3.8%	S1280 to Humboldt	XS300089>300678>\$1
635034	CLRNDA 5	161.0	560001	NODAWAYCO	161.0	1	153	146.4	146.7	3.8%	S1280 to Humboldt	XS300089>300726>\$1
635034	CLRNDA 5	161.0	560001	NODAWAYCO	161.0	1	153	146.4	146.7	3.8%	S1280 to Humboldt	XS300046>300103>\$2
635034	CLRNDA 5	161.0	560001	NODAWAYCO	161.0	1	153	146.4	146.7	3.8%	S1280 to Humboldt	XS300075>345790>\$1

635034	CLRND 5	161.0	560001	NODAWAYCO	161.0	1	153	146.4	146.7	3.8%	S1280 to Humboldt	XS300090>300517>\$3
635034	CLRND 5	161.0	560001	NODAWAYCO	161.0	1	153	146.4	146.7	3.8%	S1280 to Humboldt	XS300046>300103>\$1
635034	CLRND 5	161.0	560001	NODAWAYCO	161.0	1	153	146.4	146.7	3.8%	S1280 to Humboldt	XS300092>301065>\$2
635034	CLRND 5	161.0	560001	NODAWAYCO	161.0	1	153	146.4	146.7	3.8%	S1280 to Humboldt	XS300090>300517>\$2
635034	CLRND 5	161.0	560001	NODAWAYCO	161.0	1	153	146.4	146.7	3.8%	S1280 to Humboldt	XS300067>300111>\$1
635034	CLRND 5	161.0	560001	NODAWAYCO	161.0	1	153	146.4	146.7	3.8%	S1280 to Humboldt	XS300072>300092>\$1
635034	CLRND 5	161.0	560001	NODAWAYCO	161.0	1	153	146.4	146.7	3.8%	S1280 to Humboldt	XS300095>301168>\$1
635034	CLRND 5	161.0	560001	NODAWAYCO	161.0	1	153	146.5	146.7	3.8%	S1280 to Humboldt	XS300041>300047>\$1
635034	CLRND 5	161.0	560001	NODAWAYCO	161.0	1	153	146.4	146.7	3.8%	S1280 to Humboldt	XS300095>301128>\$1
635034	CLRND 5	161.0	560001	NODAWAYCO	161.0	1	153	146.4	146.7	3.8%	S1280 to Humboldt	XS300096>300643>\$1
635034	CLRND 5	161.0	560001	NODAWAYCO	161.0	1	153	146.4	146.7	3.8%	S1280 to Humboldt	XS300096>301184>\$1
635034	CLRND 5	161.0	560001	NODAWAYCO	161.0	1	153	146.4	146.7	3.8%	S1280 to Humboldt	XS300096>301184>\$2
635034	CLRND 5	161.0	560001	NODAWAYCO	161.0	1	153	146.4	146.7	3.8%	S1280 to Humboldt	XS300095>301168>\$2
635034	CLRND 5	161.0	560001	NODAWAYCO	161.0	1	153	146.4	146.7	3.8%	S1280 to Humboldt	XS300074>301136>\$1
635034	CLRND 5	161.0	560001	NODAWAYCO	161.0	1	153	146.4	146.7	3.8%	S1280 to Humboldt	XS300089>300673>\$1
635034	CLRND 5	161.0	560001	NODAWAYCO	161.0	1	153	146.4	146.7	3.8%	S1280 to Humboldt	XS300093>301212>\$1
635034	CLRND 5	161.0	560001	NODAWAYCO	161.0	1	153	146.4	146.7	3.8%	S1280 to Humboldt	XS300066>300126>\$1
635034	CLRND 5	161.0	560001	NODAWAYCO	161.0	1	153	146.4	146.7	3.8%	S1280 to Humboldt	XS300072>301048>\$1
635034	CLRND 5	161.0	560001	NODAWAYCO	161.0	1	153	146.4	146.7	3.8%	S1280 to Humboldt	XS300043>300044>\$1
635034	CLRND 5	161.0	560001	NODAWAYCO	161.0	1	153	146.4	146.7	3.8%	S1280 to Humboldt	XS300093>301212>\$2
635034	CLRND 5	161.0	560001	NODAWAYCO	161.0	1	153	146.4	146.7	3.8%	S1280 to Humboldt	XS300060>300067>\$1
635034	CLRND 5	161.0	560001	NODAWAYCO	161.0	1	153	146.4	146.7	3.8%	S1280 to Humboldt	XS300078>300096>\$2
635034	CLRND 5	161.0	560001	NODAWAYCO	161.0	1	153	146.5	146.7	3.8%	S1280 to Humboldt	XS300059>345941>\$1
635034	CLRND 5	161.0	560001	NODAWAYCO	161.0	1	153	146.4	146.7	3.8%	S1280 to Humboldt	XS300057>344026>\$1
635034	CLRND 5	161.0	560001	NODAWAYCO	161.0	1	153	146.4	146.7	3.8%	S1280 to Humboldt	XS300060>300100>\$1
635034	CLRND 5	161.0	560001	NODAWAYCO	161.0	1	153	146.4	146.7	3.8%	S1280 to Humboldt	XS300078>300096>\$1
635034	CLRND 5	161.0	560001	NODAWAYCO	161.0	1	153	146.4	146.7	3.8%	S1280 to Humboldt	XS300059>345542>\$1

635034	CLRNDA 5	161.0	560001	NODAWAYCO	161.0	1	153	146.4	146.7	3.8%	S1280 to Humboldt	XS300083>301291>\$1
635034	CLRNDA 5	161.0	560001	NODAWAYCO	161.0	1	153	146.4	146.7	3.8%	S1280 to Humboldt	XS300083>338202>\$1
635034	CLRNDA 5	161.0	560001	NODAWAYCO	161.0	1	153	146.5	146.7	3.8%	S1280 to Humboldt	S1263T1 AUTO
635034	CLRNDA 5	161.0	560001	NODAWAYCO	161.0	1	153	146.4	146.7	3.8%	S1280 to Humboldt	XS300079>345976>\$1
635034	CLRNDA 5	161.0	560001	NODAWAYCO	161.0	1	153	146.4	146.7	3.8%	S1280 to Humboldt	XS300059>300597>\$1
635034	CLRNDA 5	161.0	560001	NODAWAYCO	161.0	1	153	146.4	146.7	3.8%	S1280 to Humboldt	XS300059>300099>\$1
635034	CLRNDA 5	161.0	560001	NODAWAYCO	161.0	1	153	146.4	146.7	3.8%	S1280 to Humboldt	XS300079>301283>\$1
635034	CLRNDA 5	161.0	560001	NODAWAYCO	161.0	1	153	146.4	146.7	3.8%	S1280 to Humboldt	XS300079>344586>\$1
635034	CLRNDA 5	161.0	560001	NODAWAYCO	161.0	1	153	146.4	146.7	3.8%	S1280 to Humboldt	XS300081>301090>\$1
635034	CLRNDA 5	161.0	560001	NODAWAYCO	161.0	1	153	146.4	146.7	3.8%	S1280 to Humboldt	XS300059>300608>\$1
635034	CLRNDA 5	161.0	560001	NODAWAYCO	161.0	1	153	146.4	146.7	3.8%	S1280 to Humboldt	XS300080>301188>\$2
635034	CLRNDA 5	161.0	560001	NODAWAYCO	161.0	1	153	146.4	146.7	3.8%	S1280 to Humboldt	S1221 AUTOV3
635034	CLRNDA 5	161.0	560001	NODAWAYCO	161.0	1	153	146.4	146.7	3.8%	S1280 to Humboldt	XS300079>301283>\$2
635034	CLRNDA 5	161.0	560001	NODAWAYCO	161.0	1	153	146.4	146.7	3.8%	S1280 to Humboldt	XS300080>301188>\$1
635034	CLRNDA 5	161.0	560001	NODAWAYCO	161.0	1	153	146.4	146.7	3.8%	S1280 to Humboldt	XS300062>300160>\$1
635034	CLRNDA 5	161.0	560001	NODAWAYCO	161.0	1	153	146.4	146.7	3.8%	S1280 to Humboldt	XS300077>344179>\$1
635034	CLRNDA 5	161.0	560001	NODAWAYCO	161.0	1	153	146.4	146.7	3.8%	S1280 to Humboldt	S1210 AUTOV2
635034	CLRNDA 5	161.0	560001	NODAWAYCO	161.0	1	153	146.5	146.7	3.8%	S1280 to Humboldt	XS300087>300094>\$1
635034	CLRNDA 5	161.0	560001	NODAWAYCO	161.0	1	153	146.4	146.7	3.8%	S1280 to Humboldt	XS300053>345024>\$1
635034	CLRNDA 5	161.0	560001	NODAWAYCO	161.0	1	153	146.4	146.7	3.8%	S1280 to Humboldt	XS300053>300096>\$1
635034	CLRNDA 5	161.0	560001	NODAWAYCO	161.0	1	153	146.4	146.7	3.8%	S1280 to Humboldt	XS300077>300093>\$1
635034	CLRNDA 5	161.0	560001	NODAWAYCO	161.0	1	153	146.4	146.7	3.8%	S1280 to Humboldt	XS300075>300029>\$1
635034	CLRNDA 5	161.0	560001	NODAWAYCO	161.0	1	153	146.4	146.7	3.8%	S1280 to Humboldt	XS300071>300692>\$3
635034	CLRNDA 5	161.0	560001	NODAWAYCO	161.0	1	153	146.4	146.7	3.8%	S1280 to Humboldt	XS300062>301159>\$1
635034	CLRNDA 5	161.0	560001	NODAWAYCO	161.0	1	153	146.4	146.7	3.8%	S1280 to Humboldt	XS300089>300348>\$1
635034	CLRNDA 5	161.0	560001	NODAWAYCO	161.0	1	153	146.4	146.7	3.8%	S1280 to Humboldt	XS300077>345511>\$1
635034	CLRNDA 5	161.0	560001	NODAWAYCO	161.0	1	153	146.4	146.7	3.8%	S1280 to Humboldt	XS300084>301207>\$1

635034	CLRND 5	161.0	560001	NODAWAYCO	161.0	1	153	146.4	146.7	3.8%	S1280 to Humboldt	S1217 AUTOV2
635034	CLRND 5	161.0	560001	NODAWAYCO	161.0	1	153	146.4	146.7	3.8%	S1280 to Humboldt	XS300061>300493>\$1
635034	CLRND 5	161.0	560001	NODAWAYCO	161.0	1	153	146.4	146.7	3.8%	S1280 to Humboldt	XS300056>301194>\$2
635034	CLRND 5	161.0	560001	NODAWAYCO	161.0	1	153	146.4	146.7	3.8%	S1280 to Humboldt	XS300061>300501>\$1
635034	CLRND 5	161.0	560001	NODAWAYCO	161.0	1	153	146.4	146.7	3.8%	S1280 to Humboldt	XS300055>300609>\$1
635034	CLRND 5	161.0	560001	NODAWAYCO	161.0	1	153	146.4	146.7	3.8%	S1280 to Humboldt	XS300055>300060>\$1
635034	CLRND 5	161.0	560001	NODAWAYCO	161.0	1	153	146.4	146.7	3.8%	S1280 to Humboldt	XS300077>344566>\$1
635034	CLRND 5	161.0	560001	NODAWAYCO	161.0	1	153	146.5	146.7	3.8%	S1280 to Humboldt	XS300086>300563>\$1
635034	CLRND 5	161.0	560001	NODAWAYCO	161.0	1	153	146.4	146.7	3.8%	S1280 to Humboldt	S993 GEN OFF
635034	CLRND 5	161.0	560001	NODAWAYCO	161.0	1	153	146.4	146.7	3.8%	S1280 to Humboldt	XS300056>301194>\$1
635034	CLRND 5	161.0	560001	NODAWAYCO	161.0	1	153	146.4	146.7	3.8%	S1280 to Humboldt	XS300035>300046>\$2
635034	CLRND 5	161.0	560001	NODAWAYCO	161.0	1	153	146.4	146.7	3.8%	S1280 to Humboldt	XS300037>300606>\$1
635034	CLRND 5	161.0	560001	NODAWAYCO	161.0	1	153	146.4	146.7	3.8%	S1280 to Humboldt	XS300070>300802>\$1
635034	CLRND 5	161.0	560001	NODAWAYCO	161.0	1	153	146.4	146.7	3.8%	S1280 to Humboldt	XS300035>338187>\$1
635034	CLRND 5	161.0	560001	NODAWAYCO	161.0	1	153	146.4	146.7	3.8%	S1280 to Humboldt	XS300102>301163>\$1
635034	CLRND 5	161.0	560001	NODAWAYCO	161.0	1	153	146.4	146.7	3.8%	S1280 to Humboldt	XS300037>300604>\$1
635034	CLRND 5	161.0	560001	NODAWAYCO	161.0	1	153	146.4	146.7	3.8%	S1280 to Humboldt	XS300067>300626>\$1
635034	CLRND 5	161.0	560001	NODAWAYCO	161.0	1	153	146.4	146.7	3.8%	S1280 to Humboldt	XS300099>300575>\$1
635034	CLRND 5	161.0	560001	NODAWAYCO	161.0	1	153	146.5	146.7	3.8%	S1280 to Humboldt	XS300038>300046>\$1
635034	CLRND 5	161.0	560001	NODAWAYCO	161.0	1	153	146.4	146.7	3.8%	S1280 to Humboldt	XS300068>300194>\$2
635034	CLRND 5	161.0	560001	NODAWAYCO	161.0	1	153	146.4	146.7	3.8%	S1280 to Humboldt	XS300070>300793>\$1
635034	CLRND 5	161.0	560001	NODAWAYCO	161.0	1	153	146.5	146.7	3.8%	S1280 to Humboldt	XS300101>547478>\$1
635034	CLRND 5	161.0	560001	NODAWAYCO	161.0	1	153	146.4	146.7	3.8%	S1280 to Humboldt	XS300068>300194>\$1
635034	CLRND 5	161.0	560001	NODAWAYCO	161.0	1	153	146.4	146.7	3.8%	S1280 to Humboldt	XS300099>300100>\$1
635034	CLRND 5	161.0	560001	NODAWAYCO	161.0	1	153	146.4	146.7	3.8%	S1280 to Humboldt	XS300101>300782>\$1
635034	CLRND 5	161.0	560001	NODAWAYCO	161.0	1	153	146.4	146.7	3.8%	S1280 to Humboldt	XS300035>300046>\$1
635034	CLRND 5	161.0	560001	NODAWAYCO	161.0	1	153	146.4	146.7	3.8%	S1280 to Humboldt	XS300071>300692>\$1

635034	CLRNDA 5	161.0	560001	NODAWAYCO	161.0	1	153	146.4	146.7	3.8%	S1280 to Humboldt	XS300069>512648>\$1
635034	CLRNDA 5	161.0	560001	NODAWAYCO	161.0	1	153	146.4	146.7	3.8%	S1280 to Humboldt	XS300067>300119>\$1
635034	CLRNDA 5	161.0	560001	NODAWAYCO	161.0	1	153	146.4	146.7	3.8%	S1280 to Humboldt	XS300102>301163>\$2
635034	CLRNDA 5	161.0	560001	NODAWAYCO	161.0	1	153	146.4	146.7	3.8%	S1280 to Humboldt	XS300597>345544>\$1
635034	CLRNDA 5	161.0	560001	NODAWAYCO	161.0	1	153	146.4	146.7	3.8%	S1280 to Humboldt	XS300596>344773>\$1
635034	CLRNDA 5	161.0	560001	NODAWAYCO	161.0	1	153	146.4	146.7	3.8%	S1280 to Humboldt	XS300596>300612>\$1
635034	CLRNDA 5	161.0	560001	NODAWAYCO	161.0	1	153	146.4	146.7	3.8%	S1280 to Humboldt	XS300606>344449>\$1
635034	CLRNDA 5	161.0	560001	NODAWAYCO	161.0	1	153	146.4	146.7	3.8%	S1280 to Humboldt	XS300508>300505>\$2
635034	CLRNDA 5	161.0	560001	NODAWAYCO	161.0	1	153	146.4	146.7	3.8%	S1280 to Humboldt	XS300508>300505>\$1
635034	CLRNDA 5	161.0	560001	NODAWAYCO	161.0	1	153	146.4	146.7	3.8%	S1280 to Humboldt	XS300593>345091>\$1
635034	CLRNDA 5	161.0	560001	NODAWAYCO	161.0	1	153	146.4	146.7	3.8%	S1280 to Humboldt	XS300719>505472>\$1
635034	CLRNDA 5	161.0	560001	NODAWAYCO	161.0	1	153	146.4	146.7	3.8%	S1280 to Humboldt	XS300138>300996>\$1
635034	CLRNDA 5	161.0	560001	NODAWAYCO	161.0	1	153	146.4	146.7	3.8%	S1280 to Humboldt	XS300766>300767>\$1
635034	CLRNDA 5	161.0	560001	NODAWAYCO	161.0	1	153	146.4	146.7	3.8%	S1280 to Humboldt	XS300756>338804>\$1
635034	CLRNDA 5	161.0	560001	NODAWAYCO	161.0	1	153	146.4	146.7	3.8%	S1280 to Humboldt	XS300756>338200>\$1
635034	CLRNDA 5	161.0	560001	NODAWAYCO	161.0	1	153	146.4	146.7	3.8%	S1280 to Humboldt	XS300756>300769>\$1
635034	CLRNDA 5	161.0	560001	NODAWAYCO	161.0	1	153	146.4	146.7	3.8%	S1280 to Humboldt	XS300740>300741>\$1
635034	CLRNDA 5	161.0	560001	NODAWAYCO	161.0	1	153	146.4	146.7	3.8%	S1280 to Humboldt	XS300600>300608>\$1
635034	CLRNDA 5	161.0	560001	NODAWAYCO	161.0	1	153	146.5	146.7	3.8%	S1280 to Humboldt	XS532871>532872>\$1
635034	CLRNDA 5	161.0	560001	NODAWAYCO	161.0	1	153	146.4	146.7	3.8%	S1280 to Humboldt	XS300719>300727>\$1
635034	CLRNDA 5	161.0	560001	NODAWAYCO	161.0	1	153	146.4	146.7	3.8%	S1280 to Humboldt	XS300678>505492>\$1
635034	CLRNDA 5	161.0	560001	NODAWAYCO	161.0	1	153	146.4	146.7	3.8%	S1280 to Humboldt	XS300608>300609>\$1
635034	CLRNDA 5	161.0	560001	NODAWAYCO	161.0	1	153	146.5	146.7	3.8%	S1280 to Humboldt	XS300606>344480>\$1
635034	CLRNDA 5	161.0	560001	NODAWAYCO	161.0	1	153	146.4	146.7	3.8%	S1280 to Humboldt	XS300740>300741>\$2
635034	CLRNDA 5	161.0	560001	NODAWAYCO	161.0	1	153	146.4	146.7	3.8%	S1280 to Humboldt	XS300600>300612>\$1
635034	CLRNDA 5	161.0	560001	NODAWAYCO	161.0	1	153	146.4	146.7	3.8%	S1280 to Humboldt	XS300726>300805>\$1
635034	CLRNDA 5	161.0	560001	NODAWAYCO	161.0	1	153	146.4	146.7	3.8%	S1280 to Humboldt	XS300146>301339>\$1

635034	CLRNDA 5	161.0	560001	NODAWAYCO	161.0	1	153	146.4	146.7	3.8%	S1280 to Humboldt	XS300145>300931>\$1
635034	CLRNDA 5	161.0	560001	NODAWAYCO	161.0	1	153	146.4	146.7	3.8%	S1280 to Humboldt	XS300143>300850>\$1
635034	CLRNDA 5	161.0	560001	NODAWAYCO	161.0	1	153	146.4	146.7	3.8%	S1280 to Humboldt	XS300143>300844>\$1
635034	CLRNDA 5	161.0	560001	NODAWAYCO	161.0	1	153	146.4	146.7	3.8%	S1280 to Humboldt	XS300141>512731>\$1
635034	CLRNDA 5	161.0	560001	NODAWAYCO	161.0	1	153	146.4	146.7	3.8%	S1280 to Humboldt	XS300141>300845>\$2
635034	CLRNDA 5	161.0	560001	NODAWAYCO	161.0	1	153	146.4	146.7	3.8%	S1280 to Humboldt	XS300141>300844>\$1
635034	CLRNDA 5	161.0	560001	NODAWAYCO	161.0	1	153	146.4	146.7	3.8%	S1280 to Humboldt	XS300165>300948>\$1
635034	CLRNDA 5	161.0	560001	NODAWAYCO	161.0	1	153	146.4	146.7	3.8%	S1280 to Humboldt	XS300140>300943>\$2
635034	CLRNDA 5	161.0	560001	NODAWAYCO	161.0	1	153	146.4	146.7	3.8%	S1280 to Humboldt	XS300140>300943>\$1
635034	CLRNDA 5	161.0	560001	NODAWAYCO	161.0	1	153	146.4	146.7	3.8%	S1280 to Humboldt	XS300139>510377>\$1
635034	CLRNDA 5	161.0	560001	NODAWAYCO	161.0	1	153	146.4	146.7	3.8%	S1280 to Humboldt	XS300139>300929>\$1
635034	CLRNDA 5	161.0	560001	NODAWAYCO	161.0	1	153	146.4	146.7	3.8%	S1280 to Humboldt	XS300141>300845>\$1
635034	CLRNDA 5	161.0	560001	NODAWAYCO	161.0	1	153	146.4	146.7	3.8%	S1280 to Humboldt	XS300766>512704>\$1
635034	CLRNDA 5	161.0	560001	NODAWAYCO	161.0	1	153	146.5	146.7	3.8%	S1280 to Humboldt	XS300500>343004>\$1
635034	CLRNDA 5	161.0	560001	NODAWAYCO	161.0	1	153	146.4	146.7	3.8%	S1280 to Humboldt	XS300793>300798>\$1
635034	CLRNDA 5	161.0	560001	NODAWAYCO	161.0	1	153	146.4	146.7	3.8%	S1280 to Humboldt	XS300480>345091>\$1
635034	CLRNDA 5	161.0	560001	NODAWAYCO	161.0	1	153	146.4	146.7	3.8%	S1280 to Humboldt	XS300480>300597>\$1
635034	CLRNDA 5	161.0	560001	NODAWAYCO	161.0	1	153	146.5	146.7	3.8%	S1280 to Humboldt	XS300146>512649>\$1
635034	CLRNDA 5	161.0	560001	NODAWAYCO	161.0	1	153	146.4	146.7	3.8%	S1280 to Humboldt	XS300339>300363>\$1
635034	CLRNDA 5	161.0	560001	NODAWAYCO	161.0	1	153	146.4	146.7	3.8%	S1280 to Humboldt	XS300146>512705>\$1
635034	CLRNDA 5	161.0	560001	NODAWAYCO	161.0	1	153	146.5	146.7	3.8%	S1280 to Humboldt	XS300274>512655>\$1
635034	CLRNDA 5	161.0	560001	NODAWAYCO	161.0	1	153	146.5	146.7	3.8%	S1280 to Humboldt	XS300274>512648>\$1
635034	CLRNDA 5	161.0	560001	NODAWAYCO	161.0	1	153	146.4	146.7	3.8%	S1280 to Humboldt	XS300168>300173>\$2
635034	CLRNDA 5	161.0	560001	NODAWAYCO	161.0	1	153	146.4	146.7	3.8%	S1280 to Humboldt	XS300168>300173>\$1
635034	CLRNDA 5	161.0	560001	NODAWAYCO	161.0	1	153	146.4	146.7	3.8%	S1280 to Humboldt	XS300167>300606>\$1
635034	CLRNDA 5	161.0	560001	NODAWAYCO	161.0	1	153	146.4	146.7	3.8%	S1280 to Humboldt	XS300165>301339>\$1
635034	CLRNDA 5	161.0	560001	NODAWAYCO	161.0	1	153	146.4	146.7	3.8%	S1280 to Humboldt	XS300501>345071>\$1

635034	CLRNDA 5 161.0	560001	NODAWAYCO 161.0	1	153	146.4	146.7	3.8%	S1280 to Humboldt	XS300348>549954>\$1
635034	CLRNDA 5 161.0	560001	NODAWAYCO 161.0	1	153	146.4	146.7	3.8%	S1280 to Humboldt	XS300766>512655>\$1
635034	CLRNDA 5 161.0	560001	NODAWAYCO 161.0	1	153	146.4	146.7	3.8%	S1280 to Humboldt	XS532774>532856>532815\$1
635034	CLRNDA 5 161.0	560001	NODAWAYCO 161.0	1	153	146.5	146.7	3.8%	S1280 to Humboldt	XS532771>533416>532810\$1
635034	CLRNDA 5 161.0	560001	NODAWAYCO 161.0	1	153	146.5	146.7	3.8%	S1280 to Humboldt	XS532853>532856>\$1
635034	CLRNDA 5 161.0	560001	NODAWAYCO 161.0	1	153	146.4	146.7	3.8%	S1280 to Humboldt	XS532771>532796>\$1
635034	CLRNDA 5 161.0	560001	NODAWAYCO 161.0	1	153	146.4	146.7	3.8%	S1280 to Humboldt	XS532780>532793>\$1
635034	CLRNDA 5 161.0	560001	NODAWAYCO 161.0	1	153	146.4	146.7	3.8%	S1280 to Humboldt	XS532769>533304>532808\$1
635034	CLRNDA 5 161.0	560001	NODAWAYCO 161.0	1	153	146.4	146.7	3.8%	S1280 to Humboldt	XS532768>532770>\$1
635034	CLRNDA 5 161.0	560001	NODAWAYCO 161.0	1	153	146.4	146.7	3.8%	S1280 to Humboldt	XS532768>532769>\$1
635034	CLRNDA 5 161.0	560001	NODAWAYCO 161.0	1	153	146.5	146.7	3.8%	S1280 to Humboldt	XS532771>533416>532807\$1
635034	CLRNDA 5 161.0	560001	NODAWAYCO 161.0	1	153	146.5	146.7	3.8%	S1280 to Humboldt	XS532797>533653>\$1
635034	CLRNDA 5 161.0	560001	NODAWAYCO 161.0	1	153	146.4	146.7	3.8%	S1280 to Humboldt	XS532796>533040>532830\$1
635034	CLRNDA 5 161.0	560001	NODAWAYCO 161.0	1	153	146.4	146.7	3.8%	S1280 to Humboldt	XS532796>533040>532829\$1
635034	CLRNDA 5 161.0	560001	NODAWAYCO 161.0	1	153	146.4	146.7	3.8%	S1280 to Humboldt	XS532794>533062>532827\$1
635034	CLRNDA 5 161.0	560001	NODAWAYCO 161.0	1	153	146.4	146.7	3.8%	S1280 to Humboldt	XS532794>533062>532826\$1
635034	CLRNDA 5 161.0	560001	NODAWAYCO 161.0	1	153	146.4	146.7	3.8%	S1280 to Humboldt	XS532774>532856>532819\$2
635034	CLRNDA 5 161.0	560001	NODAWAYCO 161.0	1	153	146.4	146.7	3.8%	S1280 to Humboldt	XS532766>532852>532806\$1
635034	CLRNDA 5 161.0	560001	NODAWAYCO 161.0	1	153	146.4	146.7	3.8%	S1280 to Humboldt	XS532791>532986>532822\$1
635034	CLRNDA 5 161.0	560001	NODAWAYCO 161.0	1	153	146.4	146.7	3.8%	S1280 to Humboldt	XS532791>532986>532821\$1
635034	CLRNDA 5 161.0	560001	NODAWAYCO 161.0	1	153	146.4	146.7	3.8%	S1280 to Humboldt	XS532791>532796>\$1
635034	CLRNDA 5 161.0	560001	NODAWAYCO 161.0	1	153	146.4	146.7	3.8%	S1280 to Humboldt	XS300858>300881>\$1
635034	CLRNDA 5 161.0	560001	NODAWAYCO 161.0	1	153	146.4	146.7	3.8%	S1280 to Humboldt	XS300997>512651>\$1
635034	CLRNDA 5 161.0	560001	NODAWAYCO 161.0	1	153	146.4	146.7	3.8%	S1280 to Humboldt	XS300997>512627>\$1
635034	CLRNDA 5 161.0	560001	NODAWAYCO 161.0	1	153	146.4	146.7	3.8%	S1280 to Humboldt	XS300996>301339>\$1
635034	CLRNDA 5 161.0	560001	NODAWAYCO 161.0	1	153	146.4	146.7	3.8%	S1280 to Humboldt	XS300993>512638>\$1
635034	CLRNDA 5 161.0	560001	NODAWAYCO 161.0	1	153	146.4	146.7	3.8%	S1280 to Humboldt	XS300993>512627>\$1

635034	CLRNDA 5	161.0	560001	NODAWAYCO	161.0	1	153	146.4	146.7	3.8%	S1280 to Humboldt	XS300867>300869>\$1
635034	CLRNDA 5	161.0	560001	NODAWAYCO	161.0	1	153	146.4	146.7	3.8%	S1280 to Humboldt	XS300844>512712>\$1
635034	CLRNDA 5	161.0	560001	NODAWAYCO	161.0	1	153	146.4	146.7	3.8%	S1280 to Humboldt	XS300832>301165>\$1
635034	CLRNDA 5	161.0	560001	NODAWAYCO	161.0	1	153	146.4	146.7	3.8%	S1280 to Humboldt	XS300832>301159>\$1
635034	CLRNDA 5	161.0	560001	NODAWAYCO	161.0	1	153	146.4	146.7	3.8%	S1280 to Humboldt	XS300805>547621>\$1
635034	CLRNDA 5	161.0	560001	NODAWAYCO	161.0	1	153	146.4	146.7	3.8%	S1280 to Humboldt	XS300795>512707>\$1
635034	CLRNDA 5	161.0	560001	NODAWAYCO	161.0	1	153	146.4	146.7	3.8%	S1280 to Humboldt	XS300795>510396>\$1
635034	CLRNDA 5	161.0	560001	NODAWAYCO	161.0	1	153	146.4	146.7	3.8%	S1280 to Humboldt	XS532863>533305>532890\$1
635034	CLRNDA 5	161.0	560001	NODAWAYCO	161.0	1	153	146.4	146.7	3.8%	S1280 to Humboldt	XS301342>300689>\$1
635034	CLRNDA 5	161.0	560001	NODAWAYCO	161.0	1	153	146.4	146.7	3.8%	S1280 to Humboldt	XS532766>532852>532805\$1
635034	CLRNDA 5	161.0	560001	NODAWAYCO	161.0	1	153	146.4	146.7	3.8%	S1280 to Humboldt	XS532861>533326>532888\$1
635034	CLRNDA 5	161.0	560001	NODAWAYCO	161.0	1	153	146.4	146.7	3.8%	S1280 to Humboldt	XS301347>301356>\$1
635034	CLRNDA 5	161.0	560001	NODAWAYCO	161.0	1	153	146.4	146.7	3.8%	S1280 to Humboldt	XS301059>301062>\$1
635034	CLRNDA 5	161.0	560001	NODAWAYCO	161.0	1	153	146.5	146.7	3.8%	S1280 to Humboldt	XS301307>512655>\$1
635034	CLRNDA 5	161.0	560001	NODAWAYCO	161.0	1	153	146.4	146.7	3.8%	S1280 to Humboldt	XS301159>549968>\$1
635034	CLRNDA 5	161.0	560001	NODAWAYCO	161.0	1	153	146.4	146.7	3.8%	S1280 to Humboldt	XS301144>301154>\$1
635034	CLRNDA 5	161.0	560001	NODAWAYCO	161.0	1	153	146.4	146.7	3.8%	S1280 to Humboldt	XS301124>338215>\$1
635034	CLRNDA 5	161.0	560001	NODAWAYCO	161.0	1	153	146.4	146.7	3.8%	S1280 to Humboldt	XS301347>301356>\$2
635034	CLRNDA 5	161.0	560001	NODAWAYCO	161.0	1	153	146.4	146.7	3.8%	S1280 to Humboldt	XS300105>300540>\$1
635034	CLRNDA 5	161.0	560001	NODAWAYCO	161.0	1	153	146.4	146.7	3.8%	S1280 to Humboldt	XS300121>345790>\$1
635034	CLRNDA 5	161.0	560001	NODAWAYCO	161.0	1	153	146.4	146.7	3.8%	S1280 to Humboldt	XS300130>300805>\$1
635034	CLRNDA 5	161.0	560001	NODAWAYCO	161.0	1	153	146.4	146.7	3.8%	S1280 to Humboldt	XS300111>300643>\$1
635034	CLRNDA 5	161.0	560001	NODAWAYCO	161.0	1	153	146.4	146.7	3.8%	S1280 to Humboldt	XS532926>532932>\$1
635034	CLRNDA 5	161.0	560001	NODAWAYCO	161.0	1	153	146.4	146.7	3.8%	S1280 to Humboldt	XS300131>300140>\$1
635034	CLRNDA 5	161.0	560001	NODAWAYCO	161.0	1	153	146.4	146.7	3.8%	S1280 to Humboldt	XS300106>300363>\$1
635034	CLRNDA 5	161.0	560001	NODAWAYCO	161.0	1	153	146.4	146.7	3.8%	S1280 to Humboldt	XS300122>301114>\$1
635034	CLRNDA 5	161.0	560001	NODAWAYCO	161.0	1	153	146.4	146.7	3.8%	S1280 to Humboldt	XS300122>301114>\$2

635034	CLRND 5	161.0	560001	NODAWAYCO	161.0	1	153	146.4	146.7	3.8%	S1280 to Humboldt	XS300130>300738>\$1
635034	CLRND 5	161.0	560001	NODAWAYCO	161.0	1	153	146.4	146.7	3.8%	S1280 to Humboldt	XS532932>533765>532953\$1
635034	CLRND 5	161.0	560001	NODAWAYCO	161.0	1	153	146.4	146.7	3.8%	S1280 to Humboldt	XS300131>505610>\$1
635034	CLRND 5	161.0	560001	NODAWAYCO	161.0	1	153	146.4	146.7	3.8%	S1280 to Humboldt	XS532937>533021>532958\$1
635034	CLRND 5	161.0	560001	NODAWAYCO	161.0	1	153	146.4	146.7	3.8%	S1280 to Humboldt	XS300124>300013>\$2
635034	CLRND 5	161.0	560001	NODAWAYCO	161.0	1	153	146.4	146.7	3.8%	S1280 to Humboldt	XS300131>300145>\$1
635034	CLRND 5	161.0	560001	NODAWAYCO	161.0	1	153	146.4	146.7	3.8%	S1280 to Humboldt	XS532932>532934>\$1
635034	CLRND 5	161.0	560001	NODAWAYCO	161.0	1	153	146.4	146.7	3.8%	S1280 to Humboldt	XS300108>300811>\$1
635034	CLRND 5	161.0	560001	NODAWAYCO	161.0	1	153	146.4	146.7	3.8%	S1280 to Humboldt	XS300124>300014>\$3
635034	CLRND 5	161.0	560001	NODAWAYCO	161.0	1	153	146.4	146.7	3.8%	S1280 to Humboldt	XS300124>300012>\$1
635034	CLRND 5	161.0	560001	NODAWAYCO	161.0	1	153	146.4	146.7	3.8%	S1280 to Humboldt	XS300123>505448>\$1
635034	CLRND 5	161.0	560001	NODAWAYCO	161.0	1	153	146.4	146.7	3.8%	S1280 to Humboldt	XS300124>300336>\$1
635034	CLRND 5	161.0	560001	NODAWAYCO	161.0	1	153	146.4	146.7	3.8%	S1280 to Humboldt	XS300111>300636>\$1
635034	CLRND 5	161.0	560001	NODAWAYCO	161.0	1	153	146.4	146.7	3.8%	S1280 to Humboldt	XS300104>300026>\$2
635034	CLRND 5	161.0	560001	NODAWAYCO	161.0	1	153	146.4	146.7	3.8%	S1280 to Humboldt	XS532937>533021>532959\$1
635034	CLRND 5	161.0	560001	NODAWAYCO	161.0	1	153	146.4	146.7	3.8%	S1280 to Humboldt	XS532932>533765>532952\$1
635034	CLRND 5	161.0	560001	NODAWAYCO	161.0	1	153	146.4	146.7	3.8%	S1280 to Humboldt	XS532926>532937>\$1
635034	CLRND 5	161.0	560001	NODAWAYCO	161.0	1	153	146.5	146.7	3.8%	S1280 to Humboldt	XS300129>505486>\$1
635034	CLRND 5	161.0	560001	NODAWAYCO	161.0	1	153	146.4	146.7	3.8%	S1280 to Humboldt	XS300106>344001>\$1
635034	CLRND 5	161.0	560001	NODAWAYCO	161.0	1	153	146.4	146.7	3.8%	S1280 to Humboldt	XS300130>300727>\$1
635034	CLRND 5	161.0	560001	NODAWAYCO	161.0	1	153	146.4	146.7	3.8%	S1280 to Humboldt	XS300110>300331>\$1
635034	CLRND 5	161.0	560001	NODAWAYCO	161.0	1	153	146.5	146.7	3.8%	S1280 to Humboldt	XS300107>300290>\$1
635034	CLRND 5	161.0	560001	NODAWAYCO	161.0	1	153	146.4	146.7	3.8%	S1280 to Humboldt	XS300119>301152>\$2
635034	CLRND 5	161.0	560001	NODAWAYCO	161.0	1	153	146.4	146.7	3.8%	S1280 to Humboldt	XS532981>532982>\$1
635034	CLRND 5	161.0	560001	NODAWAYCO	161.0	1	153	146.4	146.7	3.8%	S1280 to Humboldt	XS300137>300889>\$1
635034	CLRND 5	161.0	560001	NODAWAYCO	161.0	1	153	146.4	146.7	3.8%	S1280 to Humboldt	XS300119>301152>\$1
635034	CLRND 5	161.0	560001	NODAWAYCO	161.0	1	153	146.4	146.7	3.8%	S1280 to Humboldt	XS300119>301136>\$1

635034	CLRNDA 5	161.0	560001	NODAWAYCO	161.0	1	153	146.4	146.7	3.8%	S1280 to Humboldt	XS300137>300889>\$2
635034	CLRNDA 5	161.0	560001	NODAWAYCO	161.0	1	153	146.4	146.7	3.8%	S1280 to Humboldt	XS300103>338201>\$1
635034	CLRNDA 5	161.0	560001	NODAWAYCO	161.0	1	153	146.4	146.7	3.8%	S1280 to Humboldt	XS532934>533639>532955\$1
635034	CLRNDA 5	161.0	560001	NODAWAYCO	161.0	1	153	146.4	146.7	3.8%	S1280 to Humboldt	XS300112>301027>\$1
635034	CLRNDA 5	161.0	560001	NODAWAYCO	161.0	1	153	146.4	146.7	3.8%	S1280 to Humboldt	XS300138>300140>\$1
635034	CLRNDA 5	161.0	560001	NODAWAYCO	161.0	1	153	146.4	146.7	3.8%	S1280 to Humboldt	XS300118>547605>547719\$1
635034	CLRNDA 5	161.0	560001	NODAWAYCO	161.0	1	153	146.4	146.7	3.8%	S1280 to Humboldt	XS300115>338202>\$1
635034	CLRNDA 5	161.0	560001	NODAWAYCO	161.0	1	153	146.4	146.7	3.8%	S1280 to Humboldt	XS300138>300927>\$1
635034	CLRNDA 5	161.0	560001	NODAWAYCO	161.0	1	153	146.4	146.7	3.8%	S1280 to Humboldt	XS532934>543065>\$1
635034	CLRNDA 5	161.0	560001	NODAWAYCO	161.0	1	153	146.4	146.7	3.8%	S1280 to Humboldt	XS300137>521026>\$1
635034	CLRNDA 5	161.0	560001	NODAWAYCO	161.0	1	153	146.4	146.7	3.8%	S1280 to Humboldt	XS300113>300339>\$1
635034	CLRNDA 5	161.0	560001	NODAWAYCO	161.0	1	153	146.4	146.7	3.8%	S1280 to Humboldt	XS300121>345375>\$1
635034	CLRNDA 5	161.0	560001	NODAWAYCO	161.0	1	153	146.4	146.7	3.8%	S1280 to Humboldt	XS300121>301255>\$1
635034	CLRNDA 5	161.0	560001	NODAWAYCO	161.0	1	153	146.4	146.7	3.8%	S1280 to Humboldt	XS300112>301027>\$2
635034	CLRNDA 5	161.0	560001	NODAWAYCO	161.0	1	153	146.4	146.7	3.8%	S1280 to Humboldt	XS300112>301149>\$1
635034	CLRNDA 5	161.0	560001	NODAWAYCO	161.0	1	153	146.4	146.7	3.8%	S1280 to Humboldt	XS300138>300927>\$2
635034	CLRNDA 5	161.0	560001	NODAWAYCO	161.0	1	153	146.5	146.7	3.8%	S1280 to Humboldt	XS300500>345409>\$1
635034	CLRNDA 5	161.0	560001	NODAWAYCO	161.0	1	153	146.4	146.7	3.8%	S1280 to Humboldt	XS300103>505400>\$1
635034	CLRNDA 5	161.0	560001	NODAWAYCO	161.0	1	153	146.4	146.7	3.8%	S1280 to Humboldt	XS300137>300140>\$1
635034	CLRNDA 5	161.0	560001	NODAWAYCO	161.0	1	153	146.4	146.7	3.8%	S1280 to Humboldt	XS300103>505428>\$1
635034	CLRNDA 5	161.0	560001	NODAWAYCO	161.0	1	153	146.4	146.7	3.8%	S1280 to Humboldt	XS300104>300025>\$1
635034	CLRNDA 5	161.0	560001	NODAWAYCO	161.0	1	153	146.4	146.7	3.8%	S1280 to Humboldt	XS533370>533371>\$1
635034	CLRNDA 5	161.0	560001	NODAWAYCO	161.0	1	153	146.4	146.7	3.8%	S1280 to Humboldt	XS533159>533168>\$1
635034	CLRNDA 5	161.0	560001	NODAWAYCO	161.0	1	153	146.4	146.7	3.8%	S1280 to Humboldt	XS533361>533886>\$2
635034	CLRNDA 5	161.0	560001	NODAWAYCO	161.0	1	153	146.4	146.7	3.8%	S1280 to Humboldt	XS533266>533272>\$1
635034	CLRNDA 5	161.0	560001	NODAWAYCO	161.0	1	153	146.4	146.7	3.8%	S1280 to Humboldt	XS533159>533174>\$1
635034	CLRNDA 5	161.0	560001	NODAWAYCO	161.0	1	153	146.4	146.7	3.8%	S1280 to Humboldt	XS533034>533038>\$1

635034	CLRND 5	161.0	560001	NODAWAYCO	161.0	1	153	146.4	146.7	3.8%	S1280 to Humboldt	XS533265>533273>\$1
635034	CLRND 5	161.0	560001	NODAWAYCO	161.0	1	153	146.4	146.7	3.8%	S1280 to Humboldt	XS533159>533184>\$1
635034	CLRND 5	161.0	560001	NODAWAYCO	161.0	1	153	146.4	146.7	3.8%	S1280 to Humboldt	XS533158>533195>\$1
635034	CLRND 5	161.0	560001	NODAWAYCO	161.0	1	153	146.4	146.7	3.8%	S1280 to Humboldt	XS532986>533037>\$1
635034	CLRND 5	161.0	560001	NODAWAYCO	161.0	1	153	146.4	146.7	3.8%	S1280 to Humboldt	XS533268>533272>\$1
635034	CLRND 5	161.0	560001	NODAWAYCO	161.0	1	153	146.4	146.7	3.8%	S1280 to Humboldt	XS533160>533187>\$1
635034	CLRND 5	161.0	560001	NODAWAYCO	161.0	1	153	146.4	146.7	3.8%	S1280 to Humboldt	XS533033>533043>\$1
635034	CLRND 5	161.0	560001	NODAWAYCO	161.0	1	153	146.4	146.7	3.8%	S1280 to Humboldt	XS533362>533365>\$1
635034	CLRND 5	161.0	560001	NODAWAYCO	161.0	1	153	146.4	146.7	3.8%	S1280 to Humboldt	XS533262>533265>\$1
635034	CLRND 5	161.0	560001	NODAWAYCO	161.0	1	153	146.4	146.7	3.8%	S1280 to Humboldt	XS533160>533189>\$1
635034	CLRND 5	161.0	560001	NODAWAYCO	161.0	1	153	146.4	146.7	3.8%	S1280 to Humboldt	XS533160>533189>\$2
635034	CLRND 5	161.0	560001	NODAWAYCO	161.0	1	153	146.4	146.7	3.8%	S1280 to Humboldt	XS533032>533039>\$1
635034	CLRND 5	161.0	560001	NODAWAYCO	161.0	1	153	146.4	146.7	3.8%	S1280 to Humboldt	XS533362>533365>\$2
635034	CLRND 5	161.0	560001	NODAWAYCO	161.0	1	153	146.5	146.7	3.8%	S1280 to Humboldt	XS533261>533281>\$1
635034	CLRND 5	161.0	560001	NODAWAYCO	161.0	1	153	146.4	146.7	3.8%	S1280 to Humboldt	XS533033>533784>533101\$1
635034	CLRND 5	161.0	560001	NODAWAYCO	161.0	1	153	146.4	146.7	3.8%	S1280 to Humboldt	XS533035>533064>\$1
635034	CLRND 5	161.0	560001	NODAWAYCO	161.0	1	153	146.4	146.7	3.8%	S1280 to Humboldt	XS532984>532992>\$1
635034	CLRND 5	161.0	560001	NODAWAYCO	161.0	1	153	146.4	146.7	3.8%	S1280 to Humboldt	XS533361>533365>\$1
635034	CLRND 5	161.0	560001	NODAWAYCO	161.0	1	153	146.4	146.7	3.8%	S1280 to Humboldt	XS533153>533192>\$1
635034	CLRND 5	161.0	560001	NODAWAYCO	161.0	1	153	146.4	146.7	3.8%	S1280 to Humboldt	XS533001>533006>\$1
635034	CLRND 5	161.0	560001	NODAWAYCO	161.0	1	153	146.4	146.7	3.8%	S1280 to Humboldt	XS533278>533283>\$1
635034	CLRND 5	161.0	560001	NODAWAYCO	161.0	1	153	146.4	146.7	3.8%	S1280 to Humboldt	XS533153>533192>\$2
635034	CLRND 5	161.0	560001	NODAWAYCO	161.0	1	153	146.4	146.7	3.8%	S1280 to Humboldt	XS533361>533365>\$2
635034	CLRND 5	161.0	560001	NODAWAYCO	161.0	1	153	146.4	146.7	3.8%	S1280 to Humboldt	XS533273>533283>\$1
635034	CLRND 5	161.0	560001	NODAWAYCO	161.0	1	153	146.4	146.7	3.8%	S1280 to Humboldt	XS533034>533072>\$1
635034	CLRND 5	161.0	560001	NODAWAYCO	161.0	1	153	146.4	146.7	3.8%	S1280 to Humboldt	XS533364>533376>\$1
635034	CLRND 5	161.0	560001	NODAWAYCO	161.0	1	153	146.4	146.7	3.8%	S1280 to Humboldt	XS533271>533277>\$1

635034	CLRNDA 5	161.0	560001	NODAWAYCO	161.0	1	153	146.4	146.7	3.8%	S1280 to Humboldt	XS533361>533371>\$1
635034	CLRNDA 5	161.0	560001	NODAWAYCO	161.0	1	153	146.4	146.7	3.8%	S1280 to Humboldt	XS533156>533198>\$1
635034	CLRNDA 5	161.0	560001	NODAWAYCO	161.0	1	153	146.5	146.7	3.8%	S1280 to Humboldt	XS533269>533270>\$1
635034	CLRNDA 5	161.0	560001	NODAWAYCO	161.0	1	153	146.4	146.7	3.8%	S1280 to Humboldt	XS532991>533067>\$1
635034	CLRNDA 5	161.0	560001	NODAWAYCO	161.0	1	153	146.4	146.7	3.8%	S1280 to Humboldt	XS533158>533173>\$1
635034	CLRNDA 5	161.0	560001	NODAWAYCO	161.0	1	153	146.4	146.7	3.8%	S1280 to Humboldt	XS533035>533054>\$1
635034	CLRNDA 5	161.0	560001	NODAWAYCO	161.0	1	153	146.4	146.7	3.8%	S1280 to Humboldt	XS533361>533371>\$2
635034	CLRNDA 5	161.0	560001	NODAWAYCO	161.0	1	153	146.5	146.7	3.8%	S1280 to Humboldt	XS533170>533171>\$1
635034	CLRNDA 5	161.0	560001	NODAWAYCO	161.0	1	153	146.4	146.7	3.8%	S1280 to Humboldt	XS533028>533067>\$1
635034	CLRNDA 5	161.0	560001	NODAWAYCO	161.0	1	153	146.4	146.7	3.8%	S1280 to Humboldt	XS533166>533175>\$1
635034	CLRNDA 5	161.0	560001	NODAWAYCO	161.0	1	153	146.4	146.7	3.8%	S1280 to Humboldt	XS533167>533339>\$1
635034	CLRNDA 5	161.0	560001	NODAWAYCO	161.0	1	153	146.4	146.7	3.8%	S1280 to Humboldt	XS533028>533048>\$1
635034	CLRNDA 5	161.0	560001	NODAWAYCO	161.0	1	153	146.4	146.7	3.8%	S1280 to Humboldt	XS533368>533372>\$1
635034	CLRNDA 5	161.0	560001	NODAWAYCO	161.0	1	153	146.4	146.7	3.8%	S1280 to Humboldt	XS533167>533339>\$2
635034	CLRNDA 5	161.0	560001	NODAWAYCO	161.0	1	153	146.4	146.7	3.8%	S1280 to Humboldt	XS533162>533166>\$1
635034	CLRNDA 5	161.0	560001	NODAWAYCO	161.0	1	153	146.4	146.7	3.8%	S1280 to Humboldt	XS533250>533280>\$1
635034	CLRNDA 5	161.0	560001	NODAWAYCO	161.0	1	153	146.4	146.7	3.8%	S1280 to Humboldt	XS533026>533060>\$1
635034	CLRNDA 5	161.0	560001	NODAWAYCO	161.0	1	153	146.4	146.7	3.8%	S1280 to Humboldt	XS532991>533032>\$1
635034	CLRNDA 5	161.0	560001	NODAWAYCO	161.0	1	153	146.4	146.7	3.8%	S1280 to Humboldt	XS533171>533173>\$1
635034	CLRNDA 5	161.0	560001	NODAWAYCO	161.0	1	153	146.4	146.7	3.8%	S1280 to Humboldt	XS533250>533264>\$1
635034	CLRNDA 5	161.0	560001	NODAWAYCO	161.0	1	153	146.4	146.7	3.8%	S1280 to Humboldt	XS533171>533306>\$1
635034	CLRNDA 5	161.0	560001	NODAWAYCO	161.0	1	153	146.4	146.7	3.8%	S1280 to Humboldt	XS533024>533060>\$1
635034	CLRNDA 5	161.0	560001	NODAWAYCO	161.0	1	153	146.4	146.7	3.8%	S1280 to Humboldt	XS533250>533253>\$1
635034	CLRNDA 5	161.0	560001	NODAWAYCO	161.0	1	153	146.4	146.7	3.8%	S1280 to Humboldt	XS533368>533381>\$1
635034	CLRNDA 5	161.0	560001	NODAWAYCO	161.0	1	153	146.4	146.7	3.8%	S1280 to Humboldt	XS533029>533046>\$1
635034	CLRNDA 5	161.0	560001	NODAWAYCO	161.0	1	153	146.4	146.7	3.8%	S1280 to Humboldt	XS533361>532681>\$1
635034	CLRNDA 5	161.0	560001	NODAWAYCO	161.0	1	153	146.4	146.7	3.8%	S1280 to Humboldt	XS533259>533268>\$1

635034	CLRND 5	161.0	560001	NODAWAYCO	161.0	1	153	146.4	146.7	3.8%	S1280 to Humboldt	XS533162>533168>\$1
635034	CLRND 5	161.0	560001	NODAWAYCO	161.0	1	153	146.4	146.7	3.8%	S1280 to Humboldt	XS533162>533169>\$1
635034	CLRND 5	161.0	560001	NODAWAYCO	161.0	1	153	146.4	146.7	3.8%	S1280 to Humboldt	XS533030>533033>\$1
635034	CLRND 5	161.0	560001	NODAWAYCO	161.0	1	153	146.4	146.7	3.8%	S1280 to Humboldt	XS533060>533822>533110\$1
635034	CLRND 5	161.0	560001	NODAWAYCO	161.0	1	153	146.4	146.7	3.8%	S1280 to Humboldt	XS533163>533169>\$1
635034	CLRND 5	161.0	560001	NODAWAYCO	161.0	1	153	146.4	146.7	3.8%	S1280 to Humboldt	XS533364>533377>\$1
635034	CLRND 5	161.0	560001	NODAWAYCO	161.0	1	153	146.4	146.7	3.8%	S1280 to Humboldt	XS532987>532990>\$1
635034	CLRND 5	161.0	560001	NODAWAYCO	161.0	1	153	146.4	146.7	3.8%	S1280 to Humboldt	XS533257>533280>\$1
635034	CLRND 5	161.0	560001	NODAWAYCO	161.0	1	153	146.5	146.7	3.8%	S1280 to Humboldt	XS533367>533368>\$1
635034	CLRND 5	161.0	560001	NODAWAYCO	161.0	1	153	146.4	146.7	3.8%	S1280 to Humboldt	XS532982>532984>\$1
635034	CLRND 5	161.0	560001	NODAWAYCO	161.0	1	153	146.4	146.7	3.8%	S1280 to Humboldt	XS533163>533198>\$1
635034	CLRND 5	161.0	560001	NODAWAYCO	161.0	1	153	146.5	146.7	3.8%	S1280 to Humboldt	XS533366>533380>\$1
635034	CLRND 5	161.0	560001	NODAWAYCO	161.0	1	153	146.4	146.7	3.8%	S1280 to Humboldt	XS533257>533271>\$1
635034	CLRND 5	161.0	560001	NODAWAYCO	161.0	1	153	146.4	146.7	3.8%	S1280 to Humboldt	XS533255>533273>\$1
635034	CLRND 5	161.0	560001	NODAWAYCO	161.0	1	153	146.4	146.7	3.8%	S1280 to Humboldt	XS533029>533039>\$1
635034	CLRND 5	161.0	560001	NODAWAYCO	161.0	1	153	146.5	146.7	3.8%	S1280 to Humboldt	XS533164>533165>\$1
635034	CLRND 5	161.0	560001	NODAWAYCO	161.0	1	153	146.5	146.7	3.8%	S1280 to Humboldt	XS533040>533041>\$1
635034	CLRND 5	161.0	560001	NODAWAYCO	161.0	1	153	146.5	146.7	3.8%	S1280 to Humboldt	XS533328>533335>\$1
635034	CLRND 5	161.0	560001	NODAWAYCO	161.0	1	153	146.4	146.7	3.8%	S1280 to Humboldt	XS533045>533072>\$1
635034	CLRND 5	161.0	560001	NODAWAYCO	161.0	1	153	146.4	146.7	3.8%	S1280 to Humboldt	XS533335>533341>\$1
635034	CLRND 5	161.0	560001	NODAWAYCO	161.0	1	153	146.4	146.7	3.8%	S1280 to Humboldt	XS533046>532739>\$1
635034	CLRND 5	161.0	560001	NODAWAYCO	161.0	1	153	146.4	146.7	3.8%	S1280 to Humboldt	XS533328>533330>\$1
635034	CLRND 5	161.0	560001	NODAWAYCO	161.0	1	153	146.4	146.7	3.8%	S1280 to Humboldt	XS533040>533054>\$1
635034	CLRND 5	161.0	560001	NODAWAYCO	161.0	1	153	146.4	146.7	3.8%	S1280 to Humboldt	XS533046>533795>533106\$1
635034	CLRND 5	161.0	560001	NODAWAYCO	161.0	1	153	146.4	146.7	3.8%	S1280 to Humboldt	XS533337>533348>\$1
635034	CLRND 5	161.0	560001	NODAWAYCO	161.0	1	153	146.4	146.7	3.8%	S1280 to Humboldt	XS533339>533340>\$2
635034	CLRND 5	161.0	560001	NODAWAYCO	161.0	1	153	146.4	146.7	3.8%	S1280 to Humboldt	XS533048>533066>\$1

635034	CLRND 5	161.0	560001	NODAWAYCO	161.0	1	153	146.4	146.7	3.8%	S1280 to Humboldt	XS533328>533335>\$3
635034	CLRND 5	161.0	560001	NODAWAYCO	161.0	1	153	146.4	146.7	3.8%	S1280 to Humboldt	XS532986>532990>\$1
635034	CLRND 5	161.0	560001	NODAWAYCO	161.0	1	153	146.4	146.7	3.8%	S1280 to Humboldt	XS533326>533334>\$1
635034	CLRND 5	161.0	560001	NODAWAYCO	161.0	1	153	146.4	146.7	3.8%	S1280 to Humboldt	XS533049>533051>\$1
635034	CLRND 5	161.0	560001	NODAWAYCO	161.0	1	153	146.4	146.7	3.8%	S1280 to Humboldt	XS533040>532729>\$1
635034	CLRND 5	161.0	560001	NODAWAYCO	161.0	1	153	146.4	146.7	3.8%	S1280 to Humboldt	XS533323>533362>\$1
635034	CLRND 5	161.0	560001	NODAWAYCO	161.0	1	153	146.4	146.7	3.8%	S1280 to Humboldt	XS533049>533053>\$1
635034	CLRND 5	161.0	560001	NODAWAYCO	161.0	1	153	146.4	146.7	3.8%	S1280 to Humboldt	XS533339>533340>\$1
635034	CLRND 5	161.0	560001	NODAWAYCO	161.0	1	153	146.4	146.7	3.8%	S1280 to Humboldt	XS532992>533558>533120\$1
635034	CLRND 5	161.0	560001	NODAWAYCO	161.0	1	153	146.4	146.7	3.8%	S1280 to Humboldt	XS533153>533182>\$1
635034	CLRND 5	161.0	560001	NODAWAYCO	161.0	1	153	146.4	146.7	3.8%	S1280 to Humboldt	XS533326>533335>\$1
635034	CLRND 5	161.0	560001	NODAWAYCO	161.0	1	153	146.4	146.7	3.8%	S1280 to Humboldt	XS533044>533051>\$1
635034	CLRND 5	161.0	560001	NODAWAYCO	161.0	1	153	146.5	146.7	3.8%	S1280 to Humboldt	XS532985>532992>\$1
635034	CLRND 5	161.0	560001	NODAWAYCO	161.0	1	153	146.4	146.7	3.8%	S1280 to Humboldt	XS533041>533074>\$1
635034	CLRND 5	161.0	560001	NODAWAYCO	161.0	1	153	146.4	146.7	3.8%	S1280 to Humboldt	XS533041>533053>\$1
635034	CLRND 5	161.0	560001	NODAWAYCO	161.0	1	153	146.4	146.7	3.8%	S1280 to Humboldt	XS533333>533334>\$1
635034	CLRND 5	161.0	560001	NODAWAYCO	161.0	1	153	146.4	146.7	3.8%	S1280 to Humboldt	XS533043>533064>\$1
635034	CLRND 5	161.0	560001	NODAWAYCO	161.0	1	153	146.4	146.7	3.8%	S1280 to Humboldt	XS533044>533045>\$1
635034	CLRND 5	161.0	560001	NODAWAYCO	161.0	1	153	146.4	146.7	3.8%	S1280 to Humboldt	XS533329>533342>\$1
635034	CLRND 5	161.0	560001	NODAWAYCO	161.0	1	153	146.4	146.7	3.8%	S1280 to Humboldt	XS533045>533046>\$1
635034	CLRND 5	161.0	560001	NODAWAYCO	161.0	1	153	146.4	146.7	3.8%	S1280 to Humboldt	XS533041>532724>\$1
635034	CLRND 5	161.0	560001	NODAWAYCO	161.0	1	153	146.4	146.7	3.8%	S1280 to Humboldt	XS533328>533343>\$2
635034	CLRND 5	161.0	560001	NODAWAYCO	161.0	1	153	146.4	146.7	3.8%	S1280 to Humboldt	XS533335>533340>\$1
635034	CLRND 5	161.0	560001	NODAWAYCO	161.0	1	153	146.4	146.7	3.8%	S1280 to Humboldt	XS533041>532723>\$1
635034	CLRND 5	161.0	560001	NODAWAYCO	161.0	1	153	146.4	146.7	3.8%	S1280 to Humboldt	XS533328>533343>\$1
635034	CLRND 5	161.0	560001	NODAWAYCO	161.0	1	153	146.4	146.7	3.8%	S1280 to Humboldt	XS533335>533340>\$2
635034	CLRND 5	161.0	560001	NODAWAYCO	161.0	1	153	146.4	146.7	3.8%	S1280 to Humboldt	XS533049>533806>533108\$1

635034	CLRND 5	161.0	560001	NODAWAYCO	161.0	1	153	146.4	146.7	3.8%	S1280 to Humboldt	XS533333>533347>\$1
635034	CLRND 5	161.0	560001	NODAWAYCO	161.0	1	153	146.4	146.7	3.8%	S1280 to Humboldt	XS533307>533309>\$1
635034	CLRND 5	161.0	560001	NODAWAYCO	161.0	1	153	146.4	146.7	3.8%	S1280 to Humboldt	XS533151>533167>\$1
635034	CLRND 5	161.0	560001	NODAWAYCO	161.0	1	153	146.5	146.7	3.8%	S1280 to Humboldt	XS533039>533042>\$1
635034	CLRND 5	161.0	560001	NODAWAYCO	161.0	1	153	146.4	146.7	3.8%	S1280 to Humboldt	XS533305>533309>\$1
635034	CLRND 5	161.0	560001	NODAWAYCO	161.0	1	153	146.4	146.7	3.8%	S1280 to Humboldt	XS533344>533362>\$2
635034	CLRND 5	161.0	560001	NODAWAYCO	161.0	1	153	146.4	146.7	3.8%	S1280 to Humboldt	XS533151>533167>\$2
635034	CLRND 5	161.0	560001	NODAWAYCO	161.0	1	153	146.4	146.7	3.8%	S1280 to Humboldt	XS533151>533194>\$1
635034	CLRND 5	161.0	560001	NODAWAYCO	161.0	1	153	146.4	146.7	3.8%	S1280 to Humboldt	XS533049>533805>533109\$1
635034	CLRND 5	161.0	560001	NODAWAYCO	161.0	1	153	146.4	146.7	3.8%	S1280 to Humboldt	XS533038>533074>\$1
635034	CLRND 5	161.0	560001	NODAWAYCO	161.0	1	153	146.4	146.7	3.8%	S1280 to Humboldt	XS533039>533062>\$1
635034	CLRND 5	161.0	560001	NODAWAYCO	161.0	1	153	146.4	146.7	3.8%	S1280 to Humboldt	XS532991>533604>533083\$1
635034	CLRND 5	161.0	560001	NODAWAYCO	161.0	1	153	146.4	146.7	3.8%	S1280 to Humboldt	XS532986>533035>\$1
635034	CLRND 5	161.0	560001	NODAWAYCO	161.0	1	153	146.5	146.7	3.8%	S1280 to Humboldt	XS533359>533360>\$1
635034	CLRND 5	161.0	560001	NODAWAYCO	161.0	1	153	146.4	146.7	3.8%	S1280 to Humboldt	XS533037>533060>\$1
635034	CLRND 5	161.0	560001	NODAWAYCO	161.0	1	153	146.4	146.7	3.8%	S1280 to Humboldt	XS533153>533156>\$1
635034	CLRND 5	161.0	560001	NODAWAYCO	161.0	1	153	146.4	146.7	3.8%	S1280 to Humboldt	XS533301>533309>\$1
635034	CLRND 5	161.0	560001	NODAWAYCO	161.0	1	153	146.4	146.7	3.8%	S1280 to Humboldt	XS533153>533162>\$1
635034	CLRND 5	161.0	560001	NODAWAYCO	161.0	1	153	146.4	146.7	3.8%	S1280 to Humboldt	XS533259>533266>\$1
635034	CLRND 5	161.0	560001	NODAWAYCO	161.0	1	153	146.4	146.7	3.8%	S1280 to Humboldt	XS533304>533307>\$1
635034	CLRND 5	161.0	560001	NODAWAYCO	161.0	1	153	146.4	146.7	3.8%	S1280 to Humboldt	XS533001>533005>\$1
635034	CLRND 5	161.0	560001	NODAWAYCO	161.0	1	153	146.4	146.7	3.8%	S1280 to Humboldt	XS533321>533342>\$1
635034	CLRND 5	161.0	560001	NODAWAYCO	161.0	1	153	146.4	146.7	3.8%	S1280 to Humboldt	XS533211>533471>533449\$1
635034	CLRND 5	161.0	560001	NODAWAYCO	161.0	1	153	146.4	146.7	3.8%	S1280 to Humboldt	XS533321>533330>\$1
635034	CLRND 5	161.0	560001	NODAWAYCO	161.0	1	153	146.4	146.7	3.8%	S1280 to Humboldt	XS533060>533822>533111\$1
635034	CLRND 5	161.0	560001	NODAWAYCO	161.0	1	153	146.4	146.7	3.8%	S1280 to Humboldt	XS533039>533068>\$1
635034	CLRND 5	161.0	560001	NODAWAYCO	161.0	1	153	146.4	146.7	3.8%	S1280 to Humboldt	XS533344>533362>\$1

635034	CLRND 5	161.0	560001	NODAWAYCO	161.0	1	153	146.5	146.7	3.8%	S1280 to Humboldt	XS533311>533366>\$1
635034	CLRND 5	161.0	560001	NODAWAYCO	161.0	1	153	146.4	146.7	3.8%	S1280 to Humboldt	XS533151>533166>\$1
635034	CLRND 5	161.0	560001	NODAWAYCO	161.0	1	153	146.4	146.7	3.8%	S1280 to Humboldt	XS532986>533024>\$1
635034	CLRND 5	161.0	560001	NODAWAYCO	161.0	1	153	146.4	146.7	3.8%	S1280 to Humboldt	XS533310>533311>\$1
635034	CLRND 5	161.0	560001	NODAWAYCO	161.0	1	153	146.4	146.7	3.8%	S1280 to Humboldt	XS533064>533840>533112\$1
635034	CLRND 5	161.0	560001	NODAWAYCO	161.0	1	153	146.4	146.7	3.8%	S1280 to Humboldt	XS533039>533066>\$1
635034	CLRND 5	161.0	560001	NODAWAYCO	161.0	1	153	146.4	146.7	3.8%	S1280 to Humboldt	XS533066>533842>\$1
635034	CLRND 5	161.0	560001	NODAWAYCO	161.0	1	153	146.5	146.7	3.8%	S1280 to Humboldt	XS533309>533311>\$1
635034	CLRND 5	161.0	560001	NODAWAYCO	161.0	1	153	146.4	146.7	3.8%	S1280 to Humboldt	XS533301>533304>\$1
635034	CLRND 5	161.0	560001	NODAWAYCO	161.0	1	153	146.5	146.7	3.8%	S1280 to Humboldt	XS533342>533343>\$1
635034	CLRND 5	161.0	560001	NODAWAYCO	161.0	1	153	146.4	146.7	3.8%	S1280 to Humboldt	XS533373>533378>\$1
635034	CLRND 5	161.0	560001	NODAWAYCO	161.0	1	153	146.4	146.7	3.8%	S1280 to Humboldt	XS533373>533378>\$2
635034	CLRND 5	161.0	560001	NODAWAYCO	161.0	1	153	146.4	146.7	3.8%	S1280 to Humboldt	XS533013>533429>533096\$1
635034	CLRND 5	161.0	560001	NODAWAYCO	161.0	1	153	146.4	146.7	3.8%	S1280 to Humboldt	XS533243>533261>\$1
635034	CLRND 5	161.0	560001	NODAWAYCO	161.0	1	153	146.4	146.7	3.8%	S1280 to Humboldt	XS533380>533429>\$1
635034	CLRND 5	161.0	560001	NODAWAYCO	161.0	1	153	146.4	146.7	3.8%	S1280 to Humboldt	XS533003>533697>533090\$1
635034	CLRND 5	161.0	560001	NODAWAYCO	161.0	1	153	146.4	146.7	3.8%	S1280 to Humboldt	XS533242>533272>\$1
635034	CLRND 5	161.0	560001	NODAWAYCO	161.0	1	153	146.4	146.7	3.8%	S1280 to Humboldt	XS533216>533259>\$1
635034	CLRND 5	161.0	560001	NODAWAYCO	161.0	1	153	146.5	146.7	3.8%	S1280 to Humboldt	XS533212>533217>\$1
635034	CLRND 5	161.0	560001	NODAWAYCO	161.0	1	153	146.4	146.7	3.8%	S1280 to Humboldt	XS533242>533246>\$1
635034	CLRND 5	161.0	560001	NODAWAYCO	161.0	1	153	146.4	146.7	3.8%	S1280 to Humboldt	XS533180>533192>\$1
635034	CLRND 5	161.0	560001	NODAWAYCO	161.0	1	153	146.4	146.7	3.8%	S1280 to Humboldt	XS533012>533015>\$1
635034	CLRND 5	161.0	560001	NODAWAYCO	161.0	1	153	146.4	146.7	3.8%	S1280 to Humboldt	XS532981>533543>533080\$1
635034	CLRND 5	161.0	560001	NODAWAYCO	161.0	1	153	146.4	146.7	3.8%	S1280 to Humboldt	XS532987>533583>\$1
635034	CLRND 5	161.0	560001	NODAWAYCO	161.0	1	153	146.4	146.7	3.8%	S1280 to Humboldt	XS533012>533736>533092\$1
635034	CLRND 5	161.0	560001	NODAWAYCO	161.0	1	153	146.4	146.7	3.8%	S1280 to Humboldt	XS533244>533249>\$1
635034	CLRND 5	161.0	560001	NODAWAYCO	161.0	1	153	146.4	146.7	3.8%	S1280 to Humboldt	XS532987>533583>533118\$1

635034	CLRND 5	161.0	560001	NODAWAYCO	161.0	1	153	146.4	146.7	3.8%	S1280 to Humboldt	XS532991>533026>\$1
635034	CLRND 5	161.0	560001	NODAWAYCO	161.0	1	153	146.4	146.7	3.8%	S1280 to Humboldt	XS533233>533243>\$1
635034	CLRND 5	161.0	560001	NODAWAYCO	161.0	1	153	146.4	146.7	3.8%	S1280 to Humboldt	XS533178>533190>\$2
635034	CLRND 5	161.0	560001	NODAWAYCO	161.0	1	153	146.4	146.7	3.8%	S1280 to Humboldt	XS533411>533412>\$1
635034	CLRND 5	161.0	560001	NODAWAYCO	161.0	1	153	146.4	146.7	3.8%	S1280 to Humboldt	XS533234>533236>\$1
635034	CLRND 5	161.0	560001	NODAWAYCO	161.0	1	153	146.4	146.7	3.8%	S1280 to Humboldt	XS533372>533374>\$1
635034	CLRND 5	161.0	560001	NODAWAYCO	161.0	1	153	146.4	146.7	3.8%	S1280 to Humboldt	XS533241>533264>\$1
635034	CLRND 5	161.0	560001	NODAWAYCO	161.0	1	153	146.4	146.7	3.8%	S1280 to Humboldt	XS533179>533185>\$1
635034	CLRND 5	161.0	560001	NODAWAYCO	161.0	1	153	146.4	146.7	3.8%	S1280 to Humboldt	XS533233>533244>\$1
635034	CLRND 5	161.0	560001	NODAWAYCO	161.0	1	153	146.4	146.7	3.8%	S1280 to Humboldt	XS533179>533194>\$1
635034	CLRND 5	161.0	560001	NODAWAYCO	161.0	1	153	146.4	146.7	3.8%	S1280 to Humboldt	XS533244>533246>\$1
635034	CLRND 5	161.0	560001	NODAWAYCO	161.0	1	153	146.4	146.7	3.8%	S1280 to Humboldt	XS533236>533256>\$1
635034	CLRND 5	161.0	560001	NODAWAYCO	161.0	1	153	146.4	146.7	3.8%	S1280 to Humboldt	XS533372>533377>\$1
635034	CLRND 5	161.0	560001	NODAWAYCO	161.0	1	153	146.4	146.7	3.8%	S1280 to Humboldt	XS533013>533742>533095\$1
635034	CLRND 5	161.0	560001	NODAWAYCO	161.0	1	153	146.4	146.7	3.8%	S1280 to Humboldt	XS533236>533277>\$1
635034	CLRND 5	161.0	560001	NODAWAYCO	161.0	1	153	146.4	146.7	3.8%	S1280 to Humboldt	XS533234>533241>\$1
635034	CLRND 5	161.0	560001	NODAWAYCO	161.0	1	153	146.4	146.7	3.8%	S1280 to Humboldt	XS532987>533001>\$1
635034	CLRND 5	161.0	560001	NODAWAYCO	161.0	1	153	146.4	146.7	3.8%	S1280 to Humboldt	XS533185>533186>\$1
635034	CLRND 5	161.0	560001	NODAWAYCO	161.0	1	153	146.4	146.7	3.8%	S1280 to Humboldt	XS533211>533218>\$1
635034	CLRND 5	161.0	560001	NODAWAYCO	161.0	1	153	146.4	146.7	3.8%	S1280 to Humboldt	XS533378>533379>\$1
635034	CLRND 5	161.0	560001	NODAWAYCO	161.0	1	153	146.4	146.7	3.8%	S1280 to Humboldt	XS533211>533268>\$1
635034	CLRND 5	161.0	560001	NODAWAYCO	161.0	1	153	146.4	146.7	3.8%	S1280 to Humboldt	XS533004>533698>533091\$1
635034	CLRND 5	161.0	560001	NODAWAYCO	161.0	1	153	146.4	146.7	3.8%	S1280 to Humboldt	XS533189>533190>\$1
635034	CLRND 5	161.0	560001	NODAWAYCO	161.0	1	153	146.4	146.7	3.8%	S1280 to Humboldt	XS533211>533216>\$1
635034	CLRND 5	161.0	560001	NODAWAYCO	161.0	1	153	146.4	146.7	3.8%	S1280 to Humboldt	XS533375>533381>\$1
635034	CLRND 5	161.0	560001	NODAWAYCO	161.0	1	153	146.4	146.7	3.8%	S1280 to Humboldt	XS532990>533597>533082\$1
635034	CLRND 5	161.0	560001	NODAWAYCO	161.0	1	153	146.4	146.7	3.8%	S1280 to Humboldt	XS533375>533379>\$2

635034	CLRND 5	161.0	560001	NODAWAYCO	161.0	1	153	146.4	146.7	3.8%	S1280 to Humboldt	XS533172>533177>\$1
635034	CLRND 5	161.0	560001	NODAWAYCO	161.0	1	153	146.4	146.7	3.8%	S1280 to Humboldt	XS533180>533252>\$1
635034	CLRND 5	161.0	560001	NODAWAYCO	161.0	1	153	146.4	146.7	3.8%	S1280 to Humboldt	XS533011>533736>533093\$1
635034	CLRND 5	161.0	560001	NODAWAYCO	161.0	1	153	146.4	146.7	3.8%	S1280 to Humboldt	XS533180>533462>533448\$1
635034	CLRND 5	161.0	560001	NODAWAYCO	161.0	1	153	146.4	146.7	3.8%	S1280 to Humboldt	XS533234>533252>\$1
635034	CLRND 5	161.0	560001	NODAWAYCO	161.0	1	153	146.4	146.7	3.8%	S1280 to Humboldt	XS533374>533438>\$1
635034	CLRND 5	161.0	560001	NODAWAYCO	161.0	1	153	146.4	146.7	3.8%	S1280 to Humboldt	XS533011>533012>\$1
635034	CLRND 5	161.0	560001	NODAWAYCO	161.0	1	153	146.4	146.7	3.8%	S1280 to Humboldt	XS533378>533379>\$2
635034	CLRND 5	161.0	560001	NODAWAYCO	161.0	1	153	146.4	146.7	3.8%	S1280 to Humboldt	XS533216>533475>533450\$1
635034	CLRND 5	161.0	560001	NODAWAYCO	161.0	1	153	146.4	146.7	3.8%	S1280 to Humboldt	XS533239>533278>\$1
635034	CLRND 5	161.0	560001	NODAWAYCO	161.0	1	153	146.4	146.7	3.8%	S1280 to Humboldt	XS533011>533013>\$1
635034	CLRND 5	161.0	560001	NODAWAYCO	161.0	1	153	146.4	146.7	3.8%	S1280 to Humboldt	XS533004>533006>\$1
635034	CLRND 5	161.0	560001	NODAWAYCO	161.0	1	153	146.4	146.7	3.8%	S1280 to Humboldt	XS533375>533379>\$1
635034	CLRND 5	161.0	560001	NODAWAYCO	161.0	1	153	146.4	146.7	3.8%	S1280 to Humboldt	XS533239>533255>\$1
635034	CLRND 5	161.0	560001	NODAWAYCO	161.0	1	153	146.5	146.7	3.8%	S1280 to Humboldt	XS533182>533884>\$1
635034	CLRND 5	161.0	560001	NODAWAYCO	161.0	1	153	146.4	146.7	3.8%	S1280 to Humboldt	XS533176>533182>\$1
635034	CLRND 5	161.0	560001	NODAWAYCO	161.0	1	153	146.4	146.7	3.8%	S1280 to Humboldt	XS533172>533184>\$1
635034	CLRND 5	161.0	560001	NODAWAYCO	161.0	1	153	146.4	146.7	3.8%	S1280 to Humboldt	XS533245>533256>\$1
635034	CLRND 5	161.0	560001	NODAWAYCO	161.0	1	153	146.4	146.7	3.8%	S1280 to Humboldt	XS533232>533271>\$1
635034	CLRND 5	161.0	560001	NODAWAYCO	161.0	1	153	146.4	146.7	3.8%	S1280 to Humboldt	XS533177>533182>\$1
635034	CLRND 5	161.0	560001	NODAWAYCO	161.0	1	153	146.4	146.7	3.8%	S1280 to Humboldt	XS533245>533257>\$1
635034	CLRND 5	161.0	560001	NODAWAYCO	161.0	1	153	146.4	146.7	3.8%	S1280 to Humboldt	XS533172>533186>\$1
635034	CLRND 5	161.0	560001	NODAWAYCO	161.0	1	153	146.4	146.7	3.8%	S1280 to Humboldt	XS533370>533376>\$2
635034	CLRND 5	161.0	560001	NODAWAYCO	161.0	1	153	146.4	146.7	3.8%	S1280 to Humboldt	XS533176>533195>\$1
635034	CLRND 5	161.0	560001	NODAWAYCO	161.0	1	153	146.4	146.7	3.8%	S1280 to Humboldt	XS533370>533371>\$2
635034	CLRND 5	161.0	560001	NODAWAYCO	161.0	1	153	146.4	146.7	3.8%	S1280 to Humboldt	XS532987>532991>\$1
635034	CLRND 5	161.0	560001	NODAWAYCO	161.0	1	153	146.4	146.7	3.8%	S1280 to Humboldt	XS533178>533179>\$1

635034	CLRND 5	161.0	560001	NODAWAYCO	161.0	1	153	146.4	146.7	3.8%	S1280 to Humboldt	XS533174>533461>533447\$1
635034	CLRND 5	161.0	560001	NODAWAYCO	161.0	1	153	146.4	146.7	3.8%	S1280 to Humboldt	XS533002>533003>\$1
635034	CLRND 5	161.0	560001	NODAWAYCO	161.0	1	153	146.4	146.7	3.8%	S1280 to Humboldt	XS533248>533250>\$1
635034	CLRND 5	161.0	560001	NODAWAYCO	161.0	1	153	146.4	146.7	3.8%	S1280 to Humboldt	XS533232>533250>\$1
635034	CLRND 5	161.0	560001	NODAWAYCO	161.0	1	153	146.4	146.7	3.8%	S1280 to Humboldt	XS533372>533373>\$1
635034	CLRND 5	161.0	560001	NODAWAYCO	161.0	1	153	146.4	146.7	3.8%	S1280 to Humboldt	XS533021>533768>533100\$1
635034	CLRND 5	161.0	560001	NODAWAYCO	161.0	1	153	146.4	146.7	3.8%	S1280 to Humboldt	XS533370>533376>\$1
635034	CLRND 5	161.0	560001	NODAWAYCO	161.0	1	153	146.4	146.7	3.8%	S1280 to Humboldt	XS533021>533768>533099\$1
635034	CLRND 5	161.0	560001	NODAWAYCO	161.0	1	153	146.4	146.7	3.8%	S1280 to Humboldt	XS533218>533220>\$1
635034	CLRND 5	161.0	560001	NODAWAYCO	161.0	1	153	146.4	146.7	3.8%	S1280 to Humboldt	XS533175>533185>\$1
635034	CLRND 5	161.0	560001	NODAWAYCO	161.0	1	153	146.4	146.7	3.8%	S1280 to Humboldt	XS533413>530623>\$1
635034	CLRND 5	161.0	560001	NODAWAYCO	161.0	1	153	146.4	146.7	3.8%	S1280 to Humboldt	XS533248>533252>\$1
635034	CLRND 5	161.0	560001	NODAWAYCO	161.0	1	153	146.4	146.7	3.8%	S1280 to Humboldt	XS533178>533190>\$1
635034	CLRND 5	161.0	560001	NODAWAYCO	161.0	1	153	146.5	146.7	3.8%	S1280 to Humboldt	XS533244>533268>\$2
635034	CLRND 5	161.0	560001	NODAWAYCO	161.0	1	153	146.4	146.7	3.8%	S1280 to Humboldt	XS533021>533768>532711\$1
635034	CLRND 5	161.0	560001	NODAWAYCO	161.0	1	153	146.4	146.7	3.8%	S1280 to Humboldt	XS533021>533768>533100\$2
635034	CLRND 5	161.0	560001	NODAWAYCO	161.0	1	153	146.4	146.7	3.8%	S1280 to Humboldt	XS533412>533413>\$1
635034	CLRND 5	161.0	560001	NODAWAYCO	161.0	1	153	146.4	146.7	3.8%	S1280 to Humboldt	XS532981>533543>533081\$1
635034	CLRND 5	161.0	560001	NODAWAYCO	161.0	1	153	146.4	146.7	3.8%	S1280 to Humboldt	XS533220>533484>533451\$1
635034	CLRND 5	161.0	560001	NODAWAYCO	161.0	1	153	146.5	146.7	3.8%	S1280 to Humboldt	XS652511>652532>\$1
635034	CLRND 5	161.0	560001	NODAWAYCO	161.0	1	153	146.4	146.7	3.8%	S1280 to Humboldt	XS652514>652530>\$2
635034	CLRND 5	161.0	560001	NODAWAYCO	161.0	1	153	146.4	146.7	3.8%	S1280 to Humboldt	XS652522>652531>\$1
635034	CLRND 5	161.0	560001	NODAWAYCO	161.0	1	153	146.5	146.7	3.8%	S1280 to Humboldt	XS652504>652474>\$1
635034	CLRND 5	161.0	560001	NODAWAYCO	161.0	1	153	146.4	146.7	3.8%	S1280 to Humboldt	XS659152>652479>\$1
635034	CLRND 5	161.0	560001	NODAWAYCO	161.0	1	153	146.4	146.7	3.8%	S1280 to Humboldt	XS652551>620211>\$1
635034	CLRND 5	161.0	560001	NODAWAYCO	161.0	1	153	146.4	146.7	3.8%	S1280 to Humboldt	XS652504>652531>\$1
635034	CLRND 5	161.0	560001	NODAWAYCO	161.0	1	153	146.4	146.7	3.8%	S1280 to Humboldt	XS659192>659239>\$1

635034	CLRNDA 5	161.0	560001	NODAWAYCO	161.0	1	153	146.4	146.7	3.8%	S1280 to Humboldt	XS652537>601031>\$1
635034	CLRNDA 5	161.0	560001	NODAWAYCO	161.0	1	153	146.4	146.7	3.8%	S1280 to Humboldt	XS652522>652326>\$1
635034	CLRNDA 5	161.0	560001	NODAWAYCO	161.0	1	153	146.4	146.7	3.8%	S1280 to Humboldt	XS652537>601031>\$2
635034	CLRNDA 5	161.0	560001	NODAWAYCO	161.0	1	153	146.5	146.7	3.8%	S1280 to Humboldt	XS652505>652474>\$1
635034	CLRNDA 5	161.0	560001	NODAWAYCO	161.0	1	153	146.5	146.7	3.8%	S1280 to Humboldt	XS652537>652538>652293\$1
635034	CLRNDA 5	161.0	560001	NODAWAYCO	161.0	1	153	146.4	146.7	3.8%	S1280 to Humboldt	XS652505>652524>\$1
635034	CLRNDA 5	161.0	560001	NODAWAYCO	161.0	1	153	146.4	146.7	3.8%	S1280 to Humboldt	XS652522>652533>\$1
635034	CLRNDA 5	161.0	560001	NODAWAYCO	161.0	1	153	146.4	146.7	3.8%	S1280 to Humboldt	XS652572>659134>659137\$1
635034	CLRNDA 5	161.0	560001	NODAWAYCO	161.0	1	153	146.4	146.7	3.8%	S1280 to Humboldt	XS652501>652249>\$1
635034	CLRNDA 5	161.0	560001	NODAWAYCO	161.0	1	153	146.4	146.7	3.8%	S1280 to Humboldt	XS652501>652249>\$2
635034	CLRNDA 5	161.0	560001	NODAWAYCO	161.0	1	153	146.4	146.7	3.8%	S1280 to Humboldt	XS652501>652510>\$1
635034	CLRNDA 5	161.0	560001	NODAWAYCO	161.0	1	153	146.4	146.7	3.8%	S1280 to Humboldt	XS652511>660006>\$1
635034	CLRNDA 5	161.0	560001	NODAWAYCO	161.0	1	153	146.4	146.7	3.8%	S1280 to Humboldt	XS652501>652518>\$1
635034	CLRNDA 5	161.0	560001	NODAWAYCO	161.0	1	153	146.4	146.7	3.8%	S1280 to Humboldt	XS652572>659238>\$1
635034	CLRNDA 5	161.0	560001	NODAWAYCO	161.0	1	153	146.5	146.7	3.8%	S1280 to Humboldt	XS659185>659187>\$1
635034	CLRNDA 5	161.0	560001	NODAWAYCO	161.0	1	153	146.5	146.7	3.8%	S1280 to Humboldt	XS652503>652550>\$1
635034	CLRNDA 5	161.0	560001	NODAWAYCO	161.0	1	153	146.4	146.7	3.8%	S1280 to Humboldt	XS652565>652536>\$1
635034	CLRNDA 5	161.0	560001	NODAWAYCO	161.0	1	153	146.4	146.7	3.8%	S1280 to Humboldt	XS652582>652604>652605\$1
635034	CLRNDA 5	161.0	560001	NODAWAYCO	161.0	1	153	146.4	146.7	3.8%	S1280 to Humboldt	XS652502>652517>\$1
635034	CLRNDA 5	161.0	560001	NODAWAYCO	161.0	1	153	146.4	146.7	3.8%	S1280 to Humboldt	XS659185>659186>\$1
635034	CLRNDA 5	161.0	560001	NODAWAYCO	161.0	1	153	146.4	146.7	3.8%	S1280 to Humboldt	XS652514>652515>652281\$1
635034	CLRNDA 5	161.0	560001	NODAWAYCO	161.0	1	153	146.4	146.7	3.8%	S1280 to Humboldt	XS652523>652524>652233\$1
635034	CLRNDA 5	161.0	560001	NODAWAYCO	161.0	1	153	146.4	146.7	3.8%	S1280 to Humboldt	XS652523>652524>652232\$1
635034	CLRNDA 5	161.0	560001	NODAWAYCO	161.0	1	153	146.4	146.7	3.8%	S1280 to Humboldt	XS652514>652515>652282\$2
635034	CLRNDA 5	161.0	560001	NODAWAYCO	161.0	1	153	146.5	146.7	3.8%	S1280 to Humboldt	XS652523>602004>\$1
635034	CLRNDA 5	161.0	560001	NODAWAYCO	161.0	1	153	146.4	146.7	3.8%	S1280 to Humboldt	XS652506>652507>652273\$1
635034	CLRNDA 5	161.0	560001	NODAWAYCO	161.0	1	153	146.4	146.7	3.8%	S1280 to Humboldt	XS652550>652551>652297\$1

635034	CLRNDA 5	161.0	560001	NODAWAYCO	161.0	1	153	146.4	146.7	3.8%	S1280 to Humboldt	XS652551>603030>\$1
635034	CLRNDA 5	161.0	560001	NODAWAYCO	161.0	1	153	146.4	146.7	3.8%	S1280 to Humboldt	XS652507>652514>\$2
635034	CLRNDA 5	161.0	560001	NODAWAYCO	161.0	1	153	146.4	146.7	3.8%	S1280 to Humboldt	XS652507>652519>\$1
635034	CLRNDA 5	161.0	560001	NODAWAYCO	161.0	1	153	146.4	146.7	3.8%	S1280 to Humboldt	XS652626>660007>\$1
635034	CLRNDA 5	161.0	560001	NODAWAYCO	161.0	1	153	146.4	146.7	3.8%	S1280 to Humboldt	XS652515>660003>\$1
635034	CLRNDA 5	161.0	560001	NODAWAYCO	161.0	1	153	146.4	146.7	3.8%	S1280 to Humboldt	XS652507>652519>\$2
635034	CLRNDA 5	161.0	560001	NODAWAYCO	161.0	1	153	146.4	146.7	3.8%	S1280 to Humboldt	XS652518>652252>\$1
635034	CLRNDA 5	161.0	560001	NODAWAYCO	161.0	1	153	146.4	146.7	3.8%	S1280 to Humboldt	XS652507>652519>\$3
635034	CLRNDA 5	161.0	560001	NODAWAYCO	161.0	1	153	146.4	146.7	3.8%	S1280 to Humboldt	XS652550>602007>\$1
635034	CLRNDA 5	161.0	560001	NODAWAYCO	161.0	1	153	146.4	146.7	3.8%	S1280 to Humboldt	XS652515>652535>\$1
635034	CLRNDA 5	161.0	560001	NODAWAYCO	161.0	1	153	146.4	146.7	3.8%	S1280 to Humboldt	XS652507>652519>\$4
635034	CLRNDA 5	161.0	560001	NODAWAYCO	161.0	1	153	146.4	146.7	3.8%	S1280 to Humboldt	XS652515>660009>\$1
635034	CLRNDA 5	161.0	560001	NODAWAYCO	161.0	1	153	146.4	146.7	3.8%	S1280 to Humboldt	XS652517>659121>\$1
635034	CLRNDA 5	161.0	560001	NODAWAYCO	161.0	1	153	146.4	146.7	3.8%	S1280 to Humboldt	XS652607>662100>\$1
635034	CLRNDA 5	161.0	560001	NODAWAYCO	161.0	1	153	146.4	146.7	3.8%	S1280 to Humboldt	XS652550>619975>\$1
635034	CLRNDA 5	161.0	560001	NODAWAYCO	161.0	1	153	146.4	146.7	3.8%	S1280 to Humboldt	XS652550>652551>652292\$1
635034	CLRNDA 5	161.0	560001	NODAWAYCO	161.0	1	153	146.4	146.7	3.8%	S1280 to Humboldt	XS652626>660006>\$1
635034	CLRNDA 5	161.0	560001	NODAWAYCO	161.0	1	153	146.4	146.7	3.8%	S1280 to Humboldt	XS652507>652276>\$1
635034	CLRNDA 5	161.0	560001	NODAWAYCO	161.0	1	153	146.4	146.7	3.8%	S1280 to Humboldt	XS659154>659195>\$1
635034	CLRNDA 5	161.0	560001	NODAWAYCO	161.0	1	153	146.4	146.7	3.8%	S1280 to Humboldt	XS652506>652507>652274\$1
635034	CLRNDA 5	161.0	560001	NODAWAYCO	161.0	1	153	146.5	146.7	3.8%	S1280 to Humboldt	XS659132>659187>\$1
635034	CLRNDA 5	161.0	560001	NODAWAYCO	161.0	1	153	146.5	146.7	3.8%	S1280 to Humboldt	XS652506>659105>\$1
635034	CLRNDA 5	161.0	560001	NODAWAYCO	161.0	1	153	146.4	146.7	3.8%	S1280 to Humboldt	XS652550>652554>\$1
635034	CLRNDA 5	161.0	560001	NODAWAYCO	161.0	1	153	146.4	146.7	3.8%	S1280 to Humboldt	XS652515>652528>\$1
635034	CLRNDA 5	161.0	560001	NODAWAYCO	161.0	1	153	146.4	146.7	3.8%	S1280 to Humboldt	XS652507>652276>\$2
635034	CLRNDA 5	161.0	560001	NODAWAYCO	161.0	1	153	146.5	146.7	3.8%	S1280 to Humboldt	XS652606>652609>652608\$1
635034	CLRNDA 5	161.0	560001	NODAWAYCO	161.0	1	153	146.4	146.7	3.8%	S1280 to Humboldt	XS652519>652520>\$1

635034	CLRNDA 5	161.0	560001	NODAWAYCO	161.0	1	153	146.4	146.7	3.8%	S1280 to Humboldt	XS652507>652514>\$1
635034	CLRNDA 5	161.0	560001	NODAWAYCO	161.0	1	153	146.4	146.7	3.8%	S1280 to Humboldt	XS652512>652534>\$1
635034	CLRNDA 5	161.0	560001	NODAWAYCO	161.0	1	153	146.5	146.7	3.8%	S1280 to Humboldt	XS652463>652525>\$1
635034	CLRNDA 5	161.0	560001	NODAWAYCO	161.0	1	153	146.4	146.7	3.8%	S1280 to Humboldt	XS652525>660006>\$1
635034	CLRNDA 5	161.0	560001	NODAWAYCO	161.0	1	153	146.5	146.7	3.8%	S1280 to Humboldt	XS652512>659287>\$1
635034	CLRNDA 5	161.0	560001	NODAWAYCO	161.0	1	153	146.4	146.7	3.8%	S1280 to Humboldt	XS652513>652278>\$1
635034	CLRNDA 5	161.0	560001	NODAWAYCO	161.0	1	153	146.4	146.7	3.8%	S1280 to Humboldt	XS659195>659245>\$1
635034	CLRNDA 5	161.0	560001	NODAWAYCO	161.0	1	153	146.4	146.7	3.8%	S1280 to Humboldt	XS652570>659236>\$1
635034	CLRNDA 5	161.0	560001	NODAWAYCO	161.0	1	153	146.4	146.7	3.8%	S1280 to Humboldt	XS652464>652453>\$1
635034	CLRNDA 5	161.0	560001	NODAWAYCO	161.0	1	153	146.4	146.7	3.8%	S1280 to Humboldt	XS652565>652566>652310\$1
635034	CLRNDA 5	161.0	560001	NODAWAYCO	161.0	1	153	146.4	146.7	3.8%	S1280 to Humboldt	XS652532>652288>\$1
635034	CLRNDA 5	161.0	560001	NODAWAYCO	161.0	1	153	146.4	146.7	3.8%	S1280 to Humboldt	XS652530>652531>652239\$1
635034	CLRNDA 5	161.0	560001	NODAWAYCO	161.0	1	153	146.4	146.7	3.8%	S1280 to Humboldt	XS659244>659245>\$1
635034	CLRNDA 5	161.0	560001	NODAWAYCO	161.0	1	153	146.4	146.7	3.8%	S1280 to Humboldt	XS652464>659113>\$1
635034	CLRNDA 5	161.0	560001	NODAWAYCO	161.0	1	153	146.4	146.7	3.8%	S1280 to Humboldt	XS652512>652250>\$2
635034	CLRNDA 5	161.0	560001	NODAWAYCO	161.0	1	153	146.4	146.7	3.8%	S1280 to Humboldt	XS652530>652614>\$1
635034	CLRNDA 5	161.0	560001	NODAWAYCO	161.0	1	153	146.4	146.7	3.8%	S1280 to Humboldt	XS652512>652535>\$1
635034	CLRNDA 5	161.0	560001	NODAWAYCO	161.0	1	153	146.4	146.7	3.8%	S1280 to Humboldt	XS652565>652566>652308\$1
635034	CLRNDA 5	161.0	560001	NODAWAYCO	161.0	1	153	146.4	146.7	3.8%	S1280 to Humboldt	XS652512>652533>\$1
635034	CLRNDA 5	161.0	560001	NODAWAYCO	161.0	1	153	146.4	146.7	3.8%	S1280 to Humboldt	XS652500>652531>\$1
635034	CLRNDA 5	161.0	560001	NODAWAYCO	161.0	1	153	146.4	146.7	3.8%	S1280 to Humboldt	XS652482>652264>\$1
635034	CLRNDA 5	161.0	560001	NODAWAYCO	161.0	1	153	146.4	146.7	3.8%	S1280 to Humboldt	XS652530>652539>\$1
635034	CLRNDA 5	161.0	560001	NODAWAYCO	161.0	1	153	146.4	146.7	3.8%	S1280 to Humboldt	XS652530>652531>652240\$1
635034	CLRNDA 5	161.0	560001	NODAWAYCO	161.0	1	153	146.4	146.7	3.8%	S1280 to Humboldt	XS652526>652626>652627\$1
635034	CLRNDA 5	161.0	560001	NODAWAYCO	161.0	1	153	146.5	146.7	3.8%	S1280 to Humboldt	XS652532>659121>\$1
635034	CLRNDA 5	161.0	560001	NODAWAYCO	161.0	1	153	146.4	146.7	3.8%	S1280 to Humboldt	XS659193>659239>\$1
635034	CLRNDA 5	161.0	560001	NODAWAYCO	161.0	1	153	146.4	146.7	3.8%	S1280 to Humboldt	XS652500>652504>\$1

635034	CLRNDA 5	161.0	560001	NODAWAYCO	161.0	1	153	146.4	146.7	3.8%	S1280 to Humboldt	XS652528>659123>\$1
635034	CLRNDA 5	161.0	560001	NODAWAYCO	161.0	1	153	146.4	146.7	3.8%	S1280 to Humboldt	XS652513>652279>\$1
635034	CLRNDA 5	161.0	560001	NODAWAYCO	161.0	1	153	146.4	146.7	3.8%	S1280 to Humboldt	XS652531>658094>\$1
635034	CLRNDA 5	161.0	560001	NODAWAYCO	161.0	1	153	146.5	146.7	3.8%	S1280 to Humboldt	XS652466>652441>\$1
635034	CLRNDA 5	161.0	560001	NODAWAYCO	161.0	1	153	146.4	146.7	3.8%	S1280 to Humboldt	XS652531>658088>\$1
635034	CLRNDA 5	161.0	560001	NODAWAYCO	161.0	1	153	146.5	146.7	3.8%	S1280 to Humboldt	XS652463>652510>\$1
635034	CLRNDA 5	161.0	560001	NODAWAYCO	161.0	1	153	146.4	146.7	3.8%	S1280 to Humboldt	XS652512>652250>\$1
635034	CLRNDA 5	161.0	560001	NODAWAYCO	161.0	1	153	146.4	146.7	3.8%	S1280 to Humboldt	CB938-06N-95
635034	CLRNDA 5	161.0	560001	NODAWAYCO	161.0	1	153	146.4	146.7	3.8%	S1280 to Humboldt	LES7001
635034	CLRNDA 5	161.0	560001	NODAWAYCO	161.0	1	153	146.5	146.7	3.8%	S1280 to Humboldt	CB1210-17&T7
635034	CLRNDA 5	161.0	560001	NODAWAYCO	161.0	1	153	146.4	146.7	3.8%	S1280 to Humboldt	D-CIRCUIT#8B
635034	CLRNDA 5	161.0	560001	NODAWAYCO	161.0	1	153	146.4	146.7	3.8%	S1280 to Humboldt	CB938-06S-95
635034	CLRNDA 5	161.0	560001	NODAWAYCO	161.0	1	153	146.4	146.7	3.8%	S1280 to Humboldt	CB939-30-MUD
635034	CLRNDA 5	161.0	560001	NODAWAYCO	161.0	1	153	146.4	146.7	3.8%	S1280 to Humboldt	CB930-18-39
635034	CLRNDA 5	161.0	560001	NODAWAYCO	161.0	1	153	146.4	146.7	3.8%	S1280 to Humboldt	LES6203
635034	CLRNDA 5	161.0	560001	NODAWAYCO	161.0	1	153	146.5	146.7	3.8%	S1280 to Humboldt	CB1235-34&53
635034	CLRNDA 5	161.0	560001	NODAWAYCO	161.0	1	153	146.5	146.7	3.8%	S1280 to Humboldt	ELKCTY3_GEN
635034	CLRNDA 5	161.0	560001	NODAWAYCO	161.0	1	153	146.4	146.7	3.8%	S1280 to Humboldt	LES8504
635034	CLRNDA 5	161.0	560001	NODAWAYCO	161.0	1	153	146.4	146.7	3.8%	S1280 to Humboldt	LES8505
635034	CLRNDA 5	161.0	560001	NODAWAYCO	161.0	1	153	146.5	146.7	3.8%	S1280 to Humboldt	CB971-BUSNCU
635034	CLRNDA 5	161.0	560001	NODAWAYCO	161.0	1	153	146.4	146.7	3.8%	S1280 to Humboldt	LES9002
635034	CLRNDA 5	161.0	560001	NODAWAYCO	161.0	1	153	146.4	146.7	3.8%	S1280 to Humboldt	LES9003
635034	CLRNDA 5	161.0	560001	NODAWAYCO	161.0	1	153	146.5	146.7	3.8%	S1280 to Humboldt	LES8506
635034	CLRNDA 5	161.0	560001	NODAWAYCO	161.0	1	153	146.4	146.7	3.8%	S1280 to Humboldt	CB1209-312T1
635034	CLRNDA 5	161.0	560001	NODAWAYCO	161.0	1	153	146.4	146.7	3.8%	S1280 to Humboldt	LES8503
635034	CLRNDA 5	161.0	560001	NODAWAYCO	161.0	1	153	146.4	146.7	3.8%	S1280 to Humboldt	LES7504
635034	CLRNDA 5	161.0	560001	NODAWAYCO	161.0	1	153	146.4	146.7	3.8%	S1280 to Humboldt	LES8501

635034	CLRNDA 5	161.0	560001	NODAWAYCO	161.0	1	153	146.4	146.7	3.8%	S1280 to Humboldt	CB970-EN-NCU
635034	CLRNDA 5	161.0	560001	NODAWAYCO	161.0	1	153	146.4	146.7	3.8%	S1280 to Humboldt	CB916-06-40
635034	CLRNDA 5	161.0	560001	NODAWAYCO	161.0	1	153	146.4	146.7	3.8%	S1280 to Humboldt	CB1298-51&26
635034	CLRNDA 5	161.0	560001	NODAWAYCO	161.0	1	153	146.4	146.7	3.8%	S1280 to Humboldt	CB1298-05&26
635034	CLRNDA 5	161.0	560001	NODAWAYCO	161.0	1	153	146.4	146.7	3.8%	S1280 to Humboldt	LES0006
635034	CLRNDA 5	161.0	560001	NODAWAYCO	161.0	1	153	146.4	146.7	3.8%	S1280 to Humboldt	LES3004B
635034	CLRNDA 5	161.0	560001	NODAWAYCO	161.0	1	153	146.5	146.7	3.8%	S1280 to Humboldt	CB906S69BSC2
635034	CLRNDA 5	161.0	560001	NODAWAYCO	161.0	1	153	146.4	146.7	3.8%	S1280 to Humboldt	CB914A-14-88
635034	CLRNDA 5	161.0	560001	NODAWAYCO	161.0	1	153	146.4	146.7	3.8%	S1280 to Humboldt	LES3801B
635034	CLRNDA 5	161.0	560001	NODAWAYCO	161.0	1	153	146.5	146.7	3.8%	S1280 to Humboldt	CB1259-BUS
635034	CLRNDA 5	161.0	560001	NODAWAYCO	161.0	1	153	146.4	146.7	3.8%	S1280 to Humboldt	LES3802B
635034	CLRNDA 5	161.0	560001	NODAWAYCO	161.0	1	153	146.4	146.7	3.8%	S1280 to Humboldt	CBFREM-G
635034	CLRNDA 5	161.0	560001	NODAWAYCO	161.0	1	153	146.4	146.7	3.8%	S1280 to Humboldt	901-JCT-910
635034	CLRNDA 5	161.0	560001	NODAWAYCO	161.0	1	153	146.4	146.7	3.8%	S1280 to Humboldt	CB994-BUS
635034	CLRNDA 5	161.0	560001	NODAWAYCO	161.0	1	153	146.4	146.7	3.8%	S1280 to Humboldt	BASE CASE
635034	CLRNDA 5	161.0	560001	NODAWAYCO	161.0	1	153	146.5	146.7	3.8%	S1280 to Humboldt	XS533415>533506>533444\$1
635034	CLRNDA 5	161.0	560001	NODAWAYCO	161.0	1	153	146.4	146.7	3.8%	S1280 to Humboldt	XS542966>543105>\$1
635034	CLRNDA 5	161.0	560001	NODAWAYCO	161.0	1	153	146.4	146.7	3.8%	S1280 to Humboldt	XS533435>533441>\$2
635034	CLRNDA 5	161.0	560001	NODAWAYCO	161.0	1	153	146.4	146.7	3.8%	S1280 to Humboldt	XS542992>543035>\$1
635034	CLRNDA 5	161.0	560001	NODAWAYCO	161.0	1	153	146.4	146.7	3.8%	S1280 to Humboldt	XS543031>546742>\$1
635034	CLRNDA 5	161.0	560001	NODAWAYCO	161.0	1	153	146.4	146.7	3.8%	S1280 to Humboldt	XS541222>541246>\$1
635034	CLRNDA 5	161.0	560001	NODAWAYCO	161.0	1	153	146.4	146.7	3.8%	S1280 to Humboldt	XS542992>542993>\$1
635034	CLRNDA 5	161.0	560001	NODAWAYCO	161.0	1	153	146.4	146.7	3.8%	S1280 to Humboldt	XS541229>541267>\$1
635034	CLRNDA 5	161.0	560001	NODAWAYCO	161.0	1	153	146.4	146.7	3.8%	S1280 to Humboldt	XS533441>533455>\$1
635034	CLRNDA 5	161.0	560001	NODAWAYCO	161.0	1	153	146.5	146.7	3.8%	S1280 to Humboldt	XS541214>541161>\$1
635034	CLRNDA 5	161.0	560001	NODAWAYCO	161.0	1	153	146.5	146.7	3.8%	S1280 to Humboldt	XS541209>541217>\$1
635034	CLRNDA 5	161.0	560001	NODAWAYCO	161.0	1	153	146.4	146.7	3.8%	S1280 to Humboldt	XS533428>533438>\$1

635034	CLRND 5	161.0	560001	NODAWAYCO	161.0	1	153	146.5	146.7	3.8%	S1280 to Humboldt	XS542993>543010>\$1
635034	CLRND 5	161.0	560001	NODAWAYCO	161.0	1	153	146.5	146.7	3.8%	S1280 to Humboldt	XS542966>543077>\$1
635034	CLRND 5	161.0	560001	NODAWAYCO	161.0	1	153	146.4	146.7	3.8%	S1280 to Humboldt	XS541230>541260>\$1
635034	CLRND 5	161.0	560001	NODAWAYCO	161.0	1	153	146.4	146.7	3.8%	S1280 to Humboldt	XS542993>543008>\$1
635034	CLRND 5	161.0	560001	NODAWAYCO	161.0	1	153	146.4	146.7	3.8%	S1280 to Humboldt	XS543031>543032>\$1
635034	CLRND 5	161.0	560001	NODAWAYCO	161.0	1	153	146.4	146.7	3.8%	S1280 to Humboldt	XS533435>533441>\$1
635034	CLRND 5	161.0	560001	NODAWAYCO	161.0	1	153	146.4	146.7	3.8%	S1280 to Humboldt	XS542985>543637>\$1
635034	CLRND 5	161.0	560001	NODAWAYCO	161.0	1	153	146.4	146.7	3.8%	S1280 to Humboldt	XS541209>541272>\$1
635034	CLRND 5	161.0	560001	NODAWAYCO	161.0	1	153	146.5	146.7	3.8%	S1280 to Humboldt	XS541213>541214>\$1
635034	CLRND 5	161.0	560001	NODAWAYCO	161.0	1	153	146.4	146.7	3.8%	S1280 to Humboldt	XS543034>543047>\$1
635034	CLRND 5	161.0	560001	NODAWAYCO	161.0	1	153	146.4	146.7	3.8%	S1280 to Humboldt	XS542969>542995>\$1
635034	CLRND 5	161.0	560001	NODAWAYCO	161.0	1	153	146.4	146.7	3.8%	S1280 to Humboldt	XS543034>543076>\$1
635034	CLRND 5	161.0	560001	NODAWAYCO	161.0	1	153	146.4	146.7	3.8%	S1280 to Humboldt	XS542985>543018>\$1
635034	CLRND 5	161.0	560001	NODAWAYCO	161.0	1	153	146.5	146.7	3.8%	S1280 to Humboldt	XS541229>541232>\$1
635034	CLRND 5	161.0	560001	NODAWAYCO	161.0	1	153	146.5	146.7	3.8%	S1280 to Humboldt	XS541214>541230>\$1
635034	CLRND 5	161.0	560001	NODAWAYCO	161.0	1	153	146.4	146.7	3.8%	S1280 to Humboldt	XS533421>532697>\$1
635034	CLRND 5	161.0	560001	NODAWAYCO	161.0	1	153	146.4	146.7	3.8%	S1280 to Humboldt	XS533415>533416>\$1
635034	CLRND 5	161.0	560001	NODAWAYCO	161.0	1	153	146.4	146.7	3.8%	S1280 to Humboldt	XS533426>533438>\$1
635034	CLRND 5	161.0	560001	NODAWAYCO	161.0	1	153	146.4	146.7	3.8%	S1280 to Humboldt	XS533438>533439>\$1
635034	CLRND 5	161.0	560001	NODAWAYCO	161.0	1	153	146.4	146.7	3.8%	S1280 to Humboldt	XS542988>542989>\$2
635034	CLRND 5	161.0	560001	NODAWAYCO	161.0	1	153	146.4	146.7	3.8%	S1280 to Humboldt	XS542969>541341>\$1
635034	CLRND 5	161.0	560001	NODAWAYCO	161.0	1	153	146.4	146.7	3.8%	S1280 to Humboldt	XS543033>543051>\$1
635034	CLRND 5	161.0	560001	NODAWAYCO	161.0	1	153	146.4	146.7	3.8%	S1280 to Humboldt	XS542988>542989>\$1
635034	CLRND 5	161.0	560001	NODAWAYCO	161.0	1	153	146.4	146.7	3.8%	S1280 to Humboldt	XS533439>530620>\$1
635034	CLRND 5	161.0	560001	NODAWAYCO	161.0	1	153	146.4	146.7	3.8%	S1280 to Humboldt	XS542987>543636>\$1
635034	CLRND 5	161.0	560001	NODAWAYCO	161.0	1	153	146.5	146.7	3.8%	S1280 to Humboldt	XS543033>543047>\$1
635034	CLRND 5	161.0	560001	NODAWAYCO	161.0	1	153	146.4	146.7	3.8%	S1280 to Humboldt	XS542987>542989>\$1

635034	CLRNDA 5	161.0	560001	NODAWAYCO	161.0	1	153	146.4	146.7	3.8%	S1280 to Humboldt	XS533416>533438>\$1
635034	CLRNDA 5	161.0	560001	NODAWAYCO	161.0	1	153	146.4	146.7	3.8%	S1280 to Humboldt	XS543032>543047>\$1
635034	CLRNDA 5	161.0	560001	NODAWAYCO	161.0	1	153	146.4	146.7	3.8%	S1280 to Humboldt	XS541341>541165>\$1
635034	CLRNDA 5	161.0	560001	NODAWAYCO	161.0	1	153	146.5	146.7	3.8%	S1280 to Humboldt	XS543017>543026>\$1
635034	CLRNDA 5	161.0	560001	NODAWAYCO	161.0	1	153	146.4	146.7	3.8%	S1280 to Humboldt	XS533426>532705>\$1
635034	CLRNDA 5	161.0	560001	NODAWAYCO	161.0	1	153	146.4	146.7	3.8%	S1280 to Humboldt	XS541341>541166>\$1
635034	CLRNDA 5	161.0	560001	NODAWAYCO	161.0	1	153	146.5	146.7	3.8%	S1280 to Humboldt	XS543019>543025>\$1
635034	CLRNDA 5	161.0	560001	NODAWAYCO	161.0	1	153	146.4	146.7	3.8%	S1280 to Humboldt	XS541208>541308>\$1
635034	CLRNDA 5	161.0	560001	NODAWAYCO	161.0	1	153	146.5	146.7	3.8%	S1280 to Humboldt	XS541232>541264>\$1
635034	CLRNDA 5	161.0	560001	NODAWAYCO	161.0	1	153	146.4	146.7	3.8%	S1280 to Humboldt	XS541341>541167>\$1
635034	CLRNDA 5	161.0	560001	NODAWAYCO	161.0	1	153	146.5	146.7	3.8%	S1280 to Humboldt	XS542998>543009>\$1
635034	CLRNDA 5	161.0	560001	NODAWAYCO	161.0	1	153	146.4	146.7	3.8%	S1280 to Humboldt	XS541341>541343>\$1
635034	CLRNDA 5	161.0	560001	NODAWAYCO	161.0	1	153	146.4	146.7	3.8%	S1280 to Humboldt	XS542997>543639>\$1
635034	CLRNDA 5	161.0	560001	NODAWAYCO	161.0	1	153	146.4	146.7	3.8%	S1280 to Humboldt	XS541341>541344>\$1
635034	CLRNDA 5	161.0	560001	NODAWAYCO	161.0	1	153	146.4	146.7	3.8%	S1280 to Humboldt	XS533421>532698>\$1
635034	CLRNDA 5	161.0	560001	NODAWAYCO	161.0	1	153	146.5	146.7	3.8%	S1280 to Humboldt	XS541214>541160>\$1
635034	CLRNDA 5	161.0	560001	NODAWAYCO	161.0	1	153	146.4	146.7	3.8%	S1280 to Humboldt	XS543004>548808>\$1
635034	CLRNDA 5	161.0	560001	NODAWAYCO	161.0	1	153	146.4	146.7	3.8%	S1280 to Humboldt	XS533421>532696>\$1
635034	CLRNDA 5	161.0	560001	NODAWAYCO	161.0	1	153	146.4	146.7	3.8%	S1280 to Humboldt	XS541224>541245>\$1
635034	CLRNDA 5	161.0	560001	NODAWAYCO	161.0	1	153	146.4	146.7	3.8%	S1280 to Humboldt	XS533419>533513>533445\$1
635034	CLRNDA 5	161.0	560001	NODAWAYCO	161.0	1	153	146.5	146.7	3.8%	S1280 to Humboldt	XS543016>543029>\$1
635034	CLRNDA 5	161.0	560001	NODAWAYCO	161.0	1	153	146.4	146.7	3.8%	S1280 to Humboldt	XS543004>548807>\$1
635034	CLRNDA 5	161.0	560001	NODAWAYCO	161.0	1	153	146.4	146.7	3.8%	S1280 to Humboldt	XS542965>542968>\$1
635034	CLRNDA 5	161.0	560001	NODAWAYCO	161.0	1	153	146.4	146.7	3.8%	S1280 to Humboldt	XS541255>541169>\$2
635034	CLRNDA 5	161.0	560001	NODAWAYCO	161.0	1	153	146.4	146.7	3.8%	S1280 to Humboldt	XS533428>532703>\$1
635034	CLRNDA 5	161.0	560001	NODAWAYCO	161.0	1	153	146.4	146.7	3.8%	S1280 to Humboldt	XS533417>533426>\$1
635034	CLRNDA 5	161.0	560001	NODAWAYCO	161.0	1	153	146.4	146.7	3.8%	S1280 to Humboldt	XS541206>541246>\$1

635034	CLRND 5	161.0	560001	NODAWAYCO	161.0	1	153	146.4	146.7	3.8%	S1280 to Humboldt	XS541224>541282>\$1
635034	CLRND 5	161.0	560001	NODAWAYCO	161.0	1	153	146.4	146.7	3.8%	S1280 to Humboldt	XS541255>541169>\$1
635034	CLRND 5	161.0	560001	NODAWAYCO	161.0	1	153	146.4	146.7	3.8%	S1280 to Humboldt	XS533428>532704>\$1
635034	CLRND 5	161.0	560001	NODAWAYCO	161.0	1	153	146.4	146.7	3.8%	S1280 to Humboldt	XS542996>543638>\$1
635034	CLRND 5	161.0	560001	NODAWAYCO	161.0	1	153	146.4	146.7	3.8%	S1280 to Humboldt	XS541223>541224>\$1
635034	CLRND 5	161.0	560001	NODAWAYCO	161.0	1	153	146.4	146.7	3.8%	S1280 to Humboldt	XS533427>533428>\$1
635034	CLRND 5	161.0	560001	NODAWAYCO	161.0	1	153	146.4	146.7	3.8%	S1280 to Humboldt	XS543020>541248>\$1
635034	CLRND 5	161.0	560001	NODAWAYCO	161.0	1	153	146.4	146.7	3.8%	S1280 to Humboldt	XS541208>541308>\$2
635034	CLRND 5	161.0	560001	NODAWAYCO	161.0	1	153	146.5	146.7	3.8%	S1280 to Humboldt	XS542997>543009>\$1
635034	CLRND 5	161.0	560001	NODAWAYCO	161.0	1	153	146.4	146.7	3.8%	S1280 to Humboldt	XS542996>543001>\$1
635034	CLRND 5	161.0	560001	NODAWAYCO	161.0	1	153	146.4	146.7	3.8%	S1280 to Humboldt	XS543020>543023>\$1
635034	CLRND 5	161.0	560001	NODAWAYCO	161.0	1	153	146.4	146.7	3.8%	S1280 to Humboldt	XS541209>300082>\$1
635034	CLRND 5	161.0	560001	NODAWAYCO	161.0	1	153	146.5	146.7	3.8%	S1280 to Humboldt	XS541207>541239>\$1
635034	CLRND 5	161.0	560001	NODAWAYCO	161.0	1	153	146.4	146.7	3.8%	S1280 to Humboldt	XS533428>532702>\$1
635034	CLRND 5	161.0	560001	NODAWAYCO	161.0	1	153	146.4	146.7	3.8%	S1280 to Humboldt	XS542996>543040>\$1
635034	CLRND 5	161.0	560001	NODAWAYCO	161.0	1	153	146.4	146.7	3.8%	S1280 to Humboldt	XS543021>543025>\$1
635034	CLRND 5	161.0	560001	NODAWAYCO	161.0	1	153	146.4	146.7	3.8%	S1280 to Humboldt	XS542988>542990>\$1
635034	CLRND 5	161.0	560001	NODAWAYCO	161.0	1	153	146.4	146.7	3.8%	S1280 to Humboldt	XS541342>541344>\$1
635034	CLRND 5	161.0	560001	NODAWAYCO	161.0	1	153	146.4	146.7	3.8%	S1280 to Humboldt	XS541228>541269>\$1
635034	CLRND 5	161.0	560001	NODAWAYCO	161.0	1	153	146.4	146.7	3.8%	S1280 to Humboldt	XS542973>543080>\$11
635034	CLRND 5	161.0	560001	NODAWAYCO	161.0	1	153	146.4	146.7	3.8%	S1280 to Humboldt	XS541239>300709>\$1
635034	CLRND 5	161.0	560001	NODAWAYCO	161.0	1	153	146.4	146.7	3.8%	S1280 to Humboldt	XS543041>546651>\$1
635034	CLRND 5	161.0	560001	NODAWAYCO	161.0	1	153	146.4	146.7	3.8%	S1280 to Humboldt	XS542985>542971>542970\$1
635034	CLRND 5	161.0	560001	NODAWAYCO	161.0	1	153	146.4	146.7	3.8%	S1280 to Humboldt	XS542985>542959>542958\$1
635034	CLRND 5	161.0	560001	NODAWAYCO	161.0	1	153	146.4	146.7	3.8%	S1280 to Humboldt	XS533413>533421>\$1
635034	CLRND 5	161.0	560001	NODAWAYCO	161.0	1	153	146.4	146.7	3.8%	S1280 to Humboldt	XS542978>543049>\$1
635034	CLRND 5	161.0	560001	NODAWAYCO	161.0	1	153	146.4	146.7	3.8%	S1280 to Humboldt	XS533414>533415>\$1

635034	CLRND 5	161.0	560001	NODAWAYCO	161.0	1	153	146.4	146.7	3.8%	S1280 to Humboldt	XS541219>541220>\$1
635034	CLRND 5	161.0	560001	NODAWAYCO	161.0	1	153	146.5	146.7	3.8%	S1280 to Humboldt	XS541248>300098>\$1
635034	CLRND 5	161.0	560001	NODAWAYCO	161.0	1	153	146.4	146.7	3.8%	S1280 to Humboldt	XS542985>542975>542974>\$1
635034	CLRND 5	161.0	560001	NODAWAYCO	161.0	1	153	146.5	146.7	3.8%	S1280 to Humboldt	XS543055>543066>\$1
635034	CLRND 5	161.0	560001	NODAWAYCO	161.0	1	153	146.4	146.7	3.8%	S1280 to Humboldt	XS542973>542976>\$1
635034	CLRND 5	161.0	560001	NODAWAYCO	161.0	1	153	146.4	146.7	3.8%	S1280 to Humboldt	XS542976>542985>\$1
635034	CLRND 5	161.0	560001	NODAWAYCO	161.0	1	153	146.5	146.7	3.8%	S1280 to Humboldt	XS542973>542997>\$2
635034	CLRND 5	161.0	560001	NODAWAYCO	161.0	1	153	146.4	146.7	3.8%	S1280 to Humboldt	XS541210>541287>\$1
635034	CLRND 5	161.0	560001	NODAWAYCO	161.0	1	153	146.4	146.7	3.8%	S1280 to Humboldt	XS533413>533416>\$2
635034	CLRND 5	161.0	560001	NODAWAYCO	161.0	1	153	146.5	146.7	3.8%	S1280 to Humboldt	XS542973>542997>\$1
635034	CLRND 5	161.0	560001	NODAWAYCO	161.0	1	153	146.5	146.7	3.8%	S1280 to Humboldt	XS541227>541229>\$1
635034	CLRND 5	161.0	560001	NODAWAYCO	161.0	1	153	146.5	146.7	3.8%	S1280 to Humboldt	XS543036>543048>\$1
635034	CLRND 5	161.0	560001	NODAWAYCO	161.0	1	153	146.4	146.7	3.8%	S1280 to Humboldt	XS542973>543080>\$12
635034	CLRND 5	161.0	560001	NODAWAYCO	161.0	1	153	146.4	146.7	3.8%	S1280 to Humboldt	XS542985>542989>\$1
635034	CLRND 5	161.0	560001	NODAWAYCO	161.0	1	153	146.5	146.7	3.8%	S1280 to Humboldt	XS542978>543048>\$1
635034	CLRND 5	161.0	560001	NODAWAYCO	161.0	1	153	146.4	146.7	3.8%	S1280 to Humboldt	XS541210>541223>\$1
635034	CLRND 5	161.0	560001	NODAWAYCO	161.0	1	153	146.4	146.7	3.8%	S1280 to Humboldt	XS542973>543000>\$1
635034	CLRND 5	161.0	560001	NODAWAYCO	161.0	1	153	146.4	146.7	3.8%	S1280 to Humboldt	XS541200>541225>541361>\$1
635034	CLRND 5	161.0	560001	NODAWAYCO	161.0	1	153	146.5	146.7	3.8%	S1280 to Humboldt	XS533413>533419>\$1
635034	CLRND 5	161.0	560001	NODAWAYCO	161.0	1	153	146.5	146.7	3.8%	S1280 to Humboldt	XS541212>541221>\$1
635034	CLRND 5	161.0	560001	NODAWAYCO	161.0	1	153	146.4	146.7	3.8%	S1280 to Humboldt	XS543035>543076>\$1
635034	CLRND 5	161.0	560001	NODAWAYCO	161.0	1	153	146.4	146.7	3.8%	S1280 to Humboldt	XS541250>541263>\$2
635034	CLRND 5	161.0	560001	NODAWAYCO	161.0	1	153	146.5	146.7	3.8%	S1280 to Humboldt	XS541212>541213>\$1
635034	CLRND 5	161.0	560001	NODAWAYCO	161.0	1	153	146.4	146.7	3.8%	S1280 to Humboldt	XS533414>533435>\$1
635034	CLRND 5	161.0	560001	NODAWAYCO	161.0	1	153	146.4	146.7	3.8%	S1280 to Humboldt	XS542985>543011>\$1
635034	CLRND 5	161.0	560001	NODAWAYCO	161.0	1	153	146.4	146.7	3.8%	S1280 to Humboldt	XS541242>541303>\$1
635034	CLRND 5	161.0	560001	NODAWAYCO	161.0	1	153	146.4	146.7	3.8%	S1280 to Humboldt	XS542985>542984>542983>\$1

635034	CLRNDA 5	161.0	560001	NODAWAYCO	161.0	1	153	146.4	146.7	3.8%	S1280 to Humboldt	XS541242>541303>\$2
635034	CLRNDA 5	161.0	560001	NODAWAYCO	161.0	1	153	146.4	146.7	3.8%	S1280 to Humboldt	XS542973>543000>\$2
635034	CLRNDA 5	161.0	560001	NODAWAYCO	161.0	1	153	146.5	146.7	3.8%	S1280 to Humboldt	XS543055>543077>\$1
635034	CLRNDA 5	161.0	560001	NODAWAYCO	161.0	1	153	146.4	146.7	3.8%	S1280 to Humboldt	XS542973>543011>\$1
635034	CLRNDA 5	161.0	560001	NODAWAYCO	161.0	1	153	146.4	146.7	3.8%	S1280 to Humboldt	XS541250>541263>\$1
635034	CLRNDA 5	161.0	560001	NODAWAYCO	161.0	1	153	146.4	146.7	3.8%	S1280 to Humboldt	XS541225>541280>\$1
635034	CLRNDA 5	161.0	560001	NODAWAYCO	161.0	1	153	146.4	146.7	3.8%	S1280 to Humboldt	XS533441>533455>\$2
635034	CLRNDA 5	161.0	560001	NODAWAYCO	161.0	1	153	146.4	146.7	3.8%	S1280 to Humboldt	XS631003>629109>\$1
635034	CLRNDA 5	161.0	560001	NODAWAYCO	161.0	1	153	146.4	146.7	3.8%	S1280 to Humboldt	XS631034>630340>\$1
635034	CLRNDA 5	161.0	560001	NODAWAYCO	161.0	1	153	146.4	146.7	3.8%	S1280 to Humboldt	XS631003>631010>\$1
635034	CLRNDA 5	161.0	560001	NODAWAYCO	161.0	1	153	146.4	146.7	3.8%	S1280 to Humboldt	XS543636>543637>\$1
635034	CLRNDA 5	161.0	560001	NODAWAYCO	161.0	1	153	146.4	146.7	3.8%	S1280 to Humboldt	XS631075>630006>\$1
635034	CLRNDA 5	161.0	560001	NODAWAYCO	161.0	1	153	146.5	146.7	3.8%	S1280 to Humboldt	XS631088>631089>\$1
635034	CLRNDA 5	161.0	560001	NODAWAYCO	161.0	1	153	146.4	146.7	3.8%	S1280 to Humboldt	XS631044>613040>\$1
635034	CLRNDA 5	161.0	560001	NODAWAYCO	161.0	1	153	146.4	146.7	3.8%	S1280 to Humboldt	XS543105>543109>\$1
635034	CLRNDA 5	161.0	560001	NODAWAYCO	161.0	1	153	146.5	146.7	3.8%	S1280 to Humboldt	XS631057>631061>\$1
635034	CLRNDA 5	161.0	560001	NODAWAYCO	161.0	1	153	146.5	146.7	3.8%	S1280 to Humboldt	XS631075>344290>\$1
635034	CLRNDA 5	161.0	560001	NODAWAYCO	161.0	1	153	146.4	146.7	3.8%	S1280 to Humboldt	XS543112>543078>\$1
635034	CLRNDA 5	161.0	560001	NODAWAYCO	161.0	1	153	146.4	146.7	3.8%	S1280 to Humboldt	XS631045>630097>\$1
635034	CLRNDA 5	161.0	560001	NODAWAYCO	161.0	1	153	146.4	146.7	3.8%	S1280 to Humboldt	XS631043>602003>\$1
635034	CLRNDA 5	161.0	560001	NODAWAYCO	161.0	1	153	146.4	146.7	3.8%	S1280 to Humboldt	XS631056>631125>\$1
635034	CLRNDA 5	161.0	560001	NODAWAYCO	161.0	1	153	146.4	146.7	3.8%	S1280 to Humboldt	XS631077>629112>\$2
635034	CLRNDA 5	161.0	560001	NODAWAYCO	161.0	1	153	146.4	146.7	3.8%	S1280 to Humboldt	XS631088>631094>\$1
635034	CLRNDA 5	161.0	560001	NODAWAYCO	161.0	1	153	146.4	146.7	3.8%	S1280 to Humboldt	XS631077>629112>\$1
635034	CLRNDA 5	161.0	560001	NODAWAYCO	161.0	1	153	146.4	146.7	3.8%	S1280 to Humboldt	XS631043>630096>\$1
635034	CLRNDA 5	161.0	560001	NODAWAYCO	161.0	1	153	146.4	146.7	3.8%	S1280 to Humboldt	XS631056>631100>\$1
635034	CLRNDA 5	161.0	560001	NODAWAYCO	161.0	1	153	146.4	146.7	3.8%	S1280 to Humboldt	XS543638>543639>\$1

635034	CLRND 5	161.0	560001	NODAWAYCO	161.0	1	153	146.4	146.7	3.8%	S1280 to Humboldt	XS631051>630256>\$1
635034	CLRND 5	161.0	560001	NODAWAYCO	161.0	1	153	146.4	146.7	3.8%	S1280 to Humboldt	XS631059>630290>\$1
635034	CLRND 5	161.0	560001	NODAWAYCO	161.0	1	153	146.4	146.7	3.8%	S1280 to Humboldt	XS631058>631061>\$1
635034	CLRND 5	161.0	560001	NODAWAYCO	161.0	1	153	146.4	146.7	3.8%	S1280 to Humboldt	XS631028>631029>\$1
635034	CLRND 5	161.0	560001	NODAWAYCO	161.0	1	153	146.4	146.7	3.8%	S1280 to Humboldt	XS631089>630017>\$1
635034	CLRND 5	161.0	560001	NODAWAYCO	161.0	1	153	146.4	146.7	3.8%	S1280 to Humboldt	XS631029>630341>\$1
635034	CLRND 5	161.0	560001	NODAWAYCO	161.0	1	153	146.5	146.7	3.8%	S1280 to Humboldt	XS543071>543072>\$1
635034	CLRND 5	161.0	560001	NODAWAYCO	161.0	1	153	146.4	146.7	3.8%	S1280 to Humboldt	XS631050>630257>\$1
635034	CLRND 5	161.0	560001	NODAWAYCO	161.0	1	153	146.4	146.7	3.8%	S1280 to Humboldt	XS631089>631147>\$1
635034	CLRND 5	161.0	560001	NODAWAYCO	161.0	1	153	146.4	146.7	3.8%	S1280 to Humboldt	XS631027>631146>\$1
635034	CLRND 5	161.0	560001	NODAWAYCO	161.0	1	153	146.4	146.7	3.8%	S1280 to Humboldt	XS631004>631008>\$1
635034	CLRND 5	161.0	560001	NODAWAYCO	161.0	1	153	146.4	146.7	3.8%	S1280 to Humboldt	XS631077>635607>\$1
635034	CLRND 5	161.0	560001	NODAWAYCO	161.0	1	153	146.4	146.7	3.8%	S1280 to Humboldt	XS543105>543108>\$1
635034	CLRND 5	161.0	560001	NODAWAYCO	161.0	1	153	146.4	146.7	3.8%	S1280 to Humboldt	XS631044>630129>\$1
635034	CLRND 5	161.0	560001	NODAWAYCO	161.0	1	153	146.5	146.7	3.8%	S1280 to Humboldt	XS631057>631120>\$1
635034	CLRND 5	161.0	560001	NODAWAYCO	161.0	1	153	146.4	146.7	3.8%	S1280 to Humboldt	XS631004>629105>\$2
635034	CLRND 5	161.0	560001	NODAWAYCO	161.0	1	153	146.4	146.7	3.8%	S1280 to Humboldt	XS543105>543107>\$1
635034	CLRND 5	161.0	560001	NODAWAYCO	161.0	1	153	146.4	146.7	3.8%	S1280 to Humboldt	XS631050>631051>\$1
635034	CLRND 5	161.0	560001	NODAWAYCO	161.0	1	153	146.4	146.7	3.8%	S1280 to Humboldt	XS631058>631059>\$1
635034	CLRND 5	161.0	560001	NODAWAYCO	161.0	1	153	146.4	146.7	3.8%	S1280 to Humboldt	XS631030>629109>\$2
635034	CLRND 5	161.0	560001	NODAWAYCO	161.0	1	153	146.4	146.7	3.8%	S1280 to Humboldt	XS543105>543106>\$1
635034	CLRND 5	161.0	560001	NODAWAYCO	161.0	1	153	146.4	146.7	3.8%	S1280 to Humboldt	XS631038>630056>\$1
635034	CLRND 5	161.0	560001	NODAWAYCO	161.0	1	153	146.4	146.7	3.8%	S1280 to Humboldt	XS631004>631081>\$1
635034	CLRND 5	161.0	560001	NODAWAYCO	161.0	1	153	146.4	146.7	3.8%	S1280 to Humboldt	XS631004>629105>\$1
635034	CLRND 5	161.0	560001	NODAWAYCO	161.0	1	153	146.4	146.7	3.8%	S1280 to Humboldt	XS631031>631167>\$1
635034	CLRND 5	161.0	560001	NODAWAYCO	161.0	1	153	146.4	146.7	3.8%	S1280 to Humboldt	XS631054>629065>\$1
635034	CLRND 5	161.0	560001	NODAWAYCO	161.0	1	153	146.5	146.7	3.8%	S1280 to Humboldt	XS631084>344290>\$1

635034	CLRND 5	161.0	560001	NODAWAYCO	161.0	1	153	146.4	146.7	3.8%	S1280 to Humboldt	XS613330>681527>\$1
635034	CLRND 5	161.0	560001	NODAWAYCO	161.0	1	153	146.4	146.7	3.8%	S1280 to Humboldt	XS631039>630064>\$1
635034	CLRND 5	161.0	560001	NODAWAYCO	161.0	1	153	146.4	146.7	3.8%	S1280 to Humboldt	XS631041>631138>\$1
635034	CLRND 5	161.0	560001	NODAWAYCO	161.0	1	153	146.4	146.7	3.8%	S1280 to Humboldt	XS631054>629064>\$1
635034	CLRND 5	161.0	560001	NODAWAYCO	161.0	1	153	146.4	146.7	3.8%	S1280 to Humboldt	XS631080>631088>\$1
635034	CLRND 5	161.0	560001	NODAWAYCO	161.0	1	153	146.4	146.7	3.8%	S1280 to Humboldt	XS631084>630013>\$1
635034	CLRND 5	161.0	560001	NODAWAYCO	161.0	1	153	146.4	146.7	3.8%	S1280 to Humboldt	XS613370>613350>\$1
635034	CLRND 5	161.0	560001	NODAWAYCO	161.0	1	153	146.4	146.7	3.8%	S1280 to Humboldt	XS613370>613350>\$2
635034	CLRND 5	161.0	560001	NODAWAYCO	161.0	1	153	146.4	146.7	3.8%	S1280 to Humboldt	XS631079>638010>\$1
635034	CLRND 5	161.0	560001	NODAWAYCO	161.0	1	153	146.5	146.7	3.8%	S1280 to Humboldt	XS631054>631055>\$1
635034	CLRND 5	161.0	560001	NODAWAYCO	161.0	1	153	146.4	146.7	3.8%	S1280 to Humboldt	XS631052>681523>\$1
635034	CLRND 5	161.0	560001	NODAWAYCO	161.0	1	153	146.5	146.7	3.8%	S1280 to Humboldt	XS631040>631041>\$1
635034	CLRND 5	161.0	560001	NODAWAYCO	161.0	1	153	146.5	146.7	3.8%	S1280 to Humboldt	XS631082>631128>\$1
635034	CLRND 5	161.0	560001	NODAWAYCO	161.0	1	153	146.4	146.7	3.8%	S1280 to Humboldt	XS631041>630081>\$1
635034	CLRND 5	161.0	560001	NODAWAYCO	161.0	1	153	146.4	146.7	3.8%	S1280 to Humboldt	XS631039>630064>\$2
635034	CLRND 5	161.0	560001	NODAWAYCO	161.0	1	153	146.4	146.7	3.8%	S1280 to Humboldt	XS631040>630066>\$2
635034	CLRND 5	161.0	560001	NODAWAYCO	161.0	1	153	146.5	146.7	3.8%	S1280 to Humboldt	XS631079>636020>\$1
635034	CLRND 5	161.0	560001	NODAWAYCO	161.0	1	153	146.4	146.7	3.8%	S1280 to Humboldt	XS631053>681530>\$1
635034	CLRND 5	161.0	560001	NODAWAYCO	161.0	1	153	146.4	146.7	3.8%	S1280 to Humboldt	XS580070>580071>\$1
635034	CLRND 5	161.0	560001	NODAWAYCO	161.0	1	153	146.5	146.7	3.8%	S1280 to Humboldt	XS631052>681528>\$1
635034	CLRND 5	161.0	560001	NODAWAYCO	161.0	1	153	146.4	146.7	3.8%	S1280 to Humboldt	XS631040>630066>\$1
635034	CLRND 5	161.0	560001	NODAWAYCO	161.0	1	153	146.4	146.7	3.8%	S1280 to Humboldt	XS580070>648500>\$1
635034	CLRND 5	161.0	560001	NODAWAYCO	161.0	1	153	146.4	146.7	3.8%	S1280 to Humboldt	XS631001>629101>\$1
635034	CLRND 5	161.0	560001	NODAWAYCO	161.0	1	153	146.4	146.7	3.8%	S1280 to Humboldt	XS618900>631039>\$1
635034	CLRND 5	161.0	560001	NODAWAYCO	161.0	1	153	146.4	146.7	3.8%	S1280 to Humboldt	XS631085>636401>\$1
635034	CLRND 5	161.0	560001	NODAWAYCO	161.0	1	153	146.4	146.7	3.8%	S1280 to Humboldt	XS631056>630280>\$1
635034	CLRND 5	161.0	560001	NODAWAYCO	161.0	1	153	146.4	146.7	3.8%	S1280 to Humboldt	XS618900>631040>\$1

635034	CLRNDA 5	161.0	560001	NODAWAYCO	161.0	1	153	146.4	146.7	3.8%	S1280 to Humboldt	XS613420>681530>\$1
635034	CLRNDA 5	161.0	560001	NODAWAYCO	161.0	1	153	146.5	146.7	3.8%	S1280 to Humboldt	XS631051>631139>\$2
635034	CLRNDA 5	161.0	560001	NODAWAYCO	161.0	1	153	146.4	146.7	3.8%	S1280 to Humboldt	XS631056>630281>\$1
635034	CLRNDA 5	161.0	560001	NODAWAYCO	161.0	1	153	146.4	146.7	3.8%	S1280 to Humboldt	XS631001>629101>\$2
635034	CLRNDA 5	161.0	560001	NODAWAYCO	161.0	1	153	146.4	146.7	3.8%	S1280 to Humboldt	XS631042>630002>\$2
635034	CLRNDA 5	161.0	560001	NODAWAYCO	161.0	1	153	146.4	146.7	3.8%	S1280 to Humboldt	XS631044>631127>\$1
635034	CLRNDA 5	161.0	560001	NODAWAYCO	161.0	1	153	146.4	146.7	3.8%	S1280 to Humboldt	XS631079>631121>\$1
635034	CLRNDA 5	161.0	560001	NODAWAYCO	161.0	1	153	146.4	146.7	3.8%	S1280 to Humboldt	XS631042>630002>\$1
635034	CLRNDA 5	161.0	560001	NODAWAYCO	161.0	1	153	146.5	146.7	3.8%	S1280 to Humboldt	XS631037>631108>\$1
635034	CLRNDA 5	161.0	560001	NODAWAYCO	161.0	1	153	146.5	146.7	3.8%	S1280 to Humboldt	XS631037>631114>\$1
635034	CLRNDA 5	161.0	560001	NODAWAYCO	161.0	1	153	146.4	146.7	3.8%	S1280 to Humboldt	XS613420>631050>\$1
635034	CLRNDA 5	161.0	560001	NODAWAYCO	161.0	1	153	146.5	146.7	3.8%	S1280 to Humboldt	XS631055>631120>\$1
635034	CLRNDA 5	161.0	560001	NODAWAYCO	161.0	1	153	146.4	146.7	3.8%	S1280 to Humboldt	XS613420>630249>\$1
635034	CLRNDA 5	161.0	560001	NODAWAYCO	161.0	1	153	146.4	146.7	3.8%	S1280 to Humboldt	XS631062>630176>\$1
635034	CLRNDA 5	161.0	560001	NODAWAYCO	161.0	1	153	146.4	146.7	3.8%	S1280 to Humboldt	XS631016>629086>\$2
635034	CLRNDA 5	161.0	560001	NODAWAYCO	161.0	1	153	146.4	146.7	3.8%	S1280 to Humboldt	XS631019>631167>\$1
635034	CLRNDA 5	161.0	560001	NODAWAYCO	161.0	1	153	146.4	146.7	3.8%	S1280 to Humboldt	XS631048>630214>\$1
635034	CLRNDA 5	161.0	560001	NODAWAYCO	161.0	1	153	146.4	146.7	3.8%	S1280 to Humboldt	XS631016>629086>\$1
635034	CLRNDA 5	161.0	560001	NODAWAYCO	161.0	1	153	146.5	146.7	3.8%	S1280 to Humboldt	XS631062>631063>\$1
635034	CLRNDA 5	161.0	560001	NODAWAYCO	161.0	1	153	146.4	146.7	3.8%	S1280 to Humboldt	XS631091>631182>\$1
635034	CLRNDA 5	161.0	560001	NODAWAYCO	161.0	1	153	146.4	146.7	3.8%	S1280 to Humboldt	XS631015>631032>\$1
635034	CLRNDA 5	161.0	560001	NODAWAYCO	161.0	1	153	146.4	146.7	3.8%	S1280 to Humboldt	XS631046>631123>\$1
635034	CLRNDA 5	161.0	560001	NODAWAYCO	161.0	1	153	146.4	146.7	3.8%	S1280 to Humboldt	XS543062>345221>\$1
635034	CLRNDA 5	161.0	560001	NODAWAYCO	161.0	1	153	146.4	146.7	3.8%	S1280 to Humboldt	XS631066>629116>\$1
635034	CLRNDA 5	161.0	560001	NODAWAYCO	161.0	1	153	146.4	146.7	3.8%	S1280 to Humboldt	XS631091>631094>\$1
635034	CLRNDA 5	161.0	560001	NODAWAYCO	161.0	1	153	146.4	146.7	3.8%	S1280 to Humboldt	XS631014>629100>\$1
635034	CLRNDA 5	161.0	560001	NODAWAYCO	161.0	1	153	146.4	146.7	3.8%	S1280 to Humboldt	XS631047>630197>\$1

635034	CLRND 5	161.0	560001	NODAWAYCO	161.0	1	153	146.4	146.7	3.8%	S1280 to Humboldt	XS631022>631023>\$1
635034	CLRND 5	161.0	560001	NODAWAYCO	161.0	1	153	146.4	146.7	3.8%	S1280 to Humboldt	XS631091>630681>\$1
635034	CLRND 5	161.0	560001	NODAWAYCO	161.0	1	153	146.4	146.7	3.8%	S1280 to Humboldt	XS543063>543094>\$1
635034	CLRND 5	161.0	560001	NODAWAYCO	161.0	1	153	146.5	146.7	3.8%	S1280 to Humboldt	XS631013>631017>\$1
635034	CLRND 5	161.0	560001	NODAWAYCO	161.0	1	153	146.4	146.7	3.8%	S1280 to Humboldt	XS631047>630198>\$1
635034	CLRND 5	161.0	560001	NODAWAYCO	161.0	1	153	146.4	146.7	3.8%	S1280 to Humboldt	XS631064>636667>\$1
635034	CLRND 5	161.0	560001	NODAWAYCO	161.0	1	153	146.4	146.7	3.8%	S1280 to Humboldt	XS631018>631031>\$1
635034	CLRND 5	161.0	560001	NODAWAYCO	161.0	1	153	146.4	146.7	3.8%	S1280 to Humboldt	XS631064>630005>\$2
635034	CLRND 5	161.0	560001	NODAWAYCO	161.0	1	153	146.4	146.7	3.8%	S1280 to Humboldt	XS631064>630005>\$1
635034	CLRND 5	161.0	560001	NODAWAYCO	161.0	1	153	146.4	146.7	3.8%	S1280 to Humboldt	XS631018>631089>\$1
635034	CLRND 5	161.0	560001	NODAWAYCO	161.0	1	153	146.4	146.7	3.8%	S1280 to Humboldt	XS631017>631032>\$1
635034	CLRND 5	161.0	560001	NODAWAYCO	161.0	1	153	146.4	146.7	3.8%	S1280 to Humboldt	XS631018>631168>\$1
635034	CLRND 5	161.0	560001	NODAWAYCO	161.0	1	153	146.4	146.7	3.8%	S1280 to Humboldt	XS631019>629087>\$1
635034	CLRND 5	161.0	560001	NODAWAYCO	161.0	1	153	146.4	146.7	3.8%	S1280 to Humboldt	XS631047>631155>\$1
635034	CLRND 5	161.0	560001	NODAWAYCO	161.0	1	153	146.4	146.7	3.8%	S1280 to Humboldt	XS631066>629117>\$1
635034	CLRND 5	161.0	560001	NODAWAYCO	161.0	1	153	146.4	146.7	3.8%	S1280 to Humboldt	XS631094>630025>\$1
635034	CLRND 5	161.0	560001	NODAWAYCO	161.0	1	153	146.4	146.7	3.8%	S1280 to Humboldt	XS631014>629100>\$2
635034	CLRND 5	161.0	560001	NODAWAYCO	161.0	1	153	146.4	146.7	3.8%	S1280 to Humboldt	XS631019>631027>\$1
635034	CLRND 5	161.0	560001	NODAWAYCO	161.0	1	153	146.4	146.7	3.8%	S1280 to Humboldt	XS631016>631168>\$1
635034	CLRND 5	161.0	560001	NODAWAYCO	161.0	1	153	146.4	146.7	3.8%	S1280 to Humboldt	XS631048>630213>\$1
635034	CLRND 5	161.0	560001	NODAWAYCO	161.0	1	153	146.4	146.7	3.8%	S1280 to Humboldt	XS631019>629087>\$2
635034	CLRND 5	161.0	560001	NODAWAYCO	161.0	1	153	146.4	146.7	3.8%	S1280 to Humboldt	XS631017>631019>\$1
635034	CLRND 5	161.0	560001	NODAWAYCO	161.0	1	153	146.4	146.7	3.8%	S1280 to Humboldt	XS631017>629085>\$1
635034	CLRND 5	161.0	560001	NODAWAYCO	161.0	1	153	146.4	146.7	3.8%	S1280 to Humboldt	XS631017>629085>\$2
635034	CLRND 5	161.0	560001	NODAWAYCO	161.0	1	153	146.4	146.7	3.8%	S1280 to Humboldt	XS631063>631065>\$1
635034	CLRND 5	161.0	560001	NODAWAYCO	161.0	1	153	146.5	146.7	3.8%	S1280 to Humboldt	XS631062>631097>\$1
635034	CLRND 5	161.0	560001	NODAWAYCO	161.0	1	153	146.4	146.7	3.8%	S1280 to Humboldt	XS631065>630004>\$1

635034	CLRND 5	161.0	560001	NODAWAYCO	161.0	1	153	146.4	146.7	3.8%	S1280 to Humboldt	XS631090>631091>\$1
635034	CLRND 5	161.0	560001	NODAWAYCO	161.0	1	153	146.4	146.7	3.8%	S1280 to Humboldt	XS631025>631146>\$1
635034	CLRND 5	161.0	560001	NODAWAYCO	161.0	1	153	146.4	146.7	3.8%	S1280 to Humboldt	XS543069>543112>\$1
635034	CLRND 5	161.0	560001	NODAWAYCO	161.0	1	153	146.4	146.7	3.8%	S1280 to Humboldt	XS631025>629089>\$2
635034	CLRND 5	161.0	560001	NODAWAYCO	161.0	1	153	146.4	146.7	3.8%	S1280 to Humboldt	XS631011>629114>\$2
635034	CLRND 5	161.0	560001	NODAWAYCO	161.0	1	153	146.4	146.7	3.8%	S1280 to Humboldt	XS631009>629104>\$1
635034	CLRND 5	161.0	560001	NODAWAYCO	161.0	1	153	146.4	146.7	3.8%	S1280 to Humboldt	XS631090>631181>\$1
635034	CLRND 5	161.0	560001	NODAWAYCO	161.0	1	153	146.4	146.7	3.8%	S1280 to Humboldt	XS631025>629089>\$1
635034	CLRND 5	161.0	560001	NODAWAYCO	161.0	1	153	146.4	146.7	3.8%	S1280 to Humboldt	XS543066>543069>\$1
635034	CLRND 5	161.0	560001	NODAWAYCO	161.0	1	153	146.5	146.7	3.8%	S1280 to Humboldt	XS631046>601002>605739\$9
635034	CLRND 5	161.0	560001	NODAWAYCO	161.0	1	153	146.4	146.7	3.8%	S1280 to Humboldt	XS631011>631028>\$1
635034	CLRND 5	161.0	560001	NODAWAYCO	161.0	1	153	146.4	146.7	3.8%	S1280 to Humboldt	XS631009>631028>\$1
635034	CLRND 5	161.0	560001	NODAWAYCO	161.0	1	153	146.5	146.7	3.8%	S1280 to Humboldt	XS631049>629083>\$1
635034	CLRND 5	161.0	560001	NODAWAYCO	161.0	1	153	146.4	146.7	3.8%	S1280 to Humboldt	XS631025>631026>\$1
635034	CLRND 5	161.0	560001	NODAWAYCO	161.0	1	153	146.5	146.7	3.8%	S1280 to Humboldt	XS631066>681520>\$1
635034	CLRND 5	161.0	560001	NODAWAYCO	161.0	1	153	146.4	146.7	3.8%	S1280 to Humboldt	XS631010>631079>\$2
635034	CLRND 5	161.0	560001	NODAWAYCO	161.0	1	153	146.4	146.7	3.8%	S1280 to Humboldt	XS631010>631079>\$3
635034	CLRND 5	161.0	560001	NODAWAYCO	161.0	1	153	146.4	146.7	3.8%	S1280 to Humboldt	XS631045>631163>\$1
635034	CLRND 5	161.0	560001	NODAWAYCO	161.0	1	153	146.4	146.7	3.8%	S1280 to Humboldt	XS631060>630282>\$1
635034	CLRND 5	161.0	560001	NODAWAYCO	161.0	1	153	146.4	146.7	3.8%	S1280 to Humboldt	XS631011>629114>\$1
635034	CLRND 5	161.0	560001	NODAWAYCO	161.0	1	153	146.4	146.7	3.8%	S1280 to Humboldt	XS631041>631138>\$2
635034	CLRND 5	161.0	560001	NODAWAYCO	161.0	1	153	146.4	146.7	3.8%	S1280 to Humboldt	XS631026>631101>\$1
635034	CLRND 5	161.0	560001	NODAWAYCO	161.0	1	153	146.4	146.7	3.8%	S1280 to Humboldt	XS631008>631009>\$1
635034	CLRND 5	161.0	560001	NODAWAYCO	161.0	1	153	146.4	146.7	3.8%	S1280 to Humboldt	XS631059>631125>\$1
635034	CLRND 5	161.0	560001	NODAWAYCO	161.0	1	153	146.4	146.7	3.8%	S1280 to Humboldt	XS631090>630026>\$1
635034	CLRND 5	161.0	560001	NODAWAYCO	161.0	1	153	146.4	146.7	3.8%	S1280 to Humboldt	XS631008>656301>\$1
635034	CLRND 5	161.0	560001	NODAWAYCO	161.0	1	153	146.4	146.7	3.8%	S1280 to Humboldt	XS631061>631098>\$1

635034	CLRND 5 161.0	560001	NODAWAYCO 161.0	1	153	146.4	146.7	3.8%	S1280 to Humboldt	XS631091>629097>\$1
635034	CLRND 5 161.0	560001	NODAWAYCO 161.0	1	153	146.4	146.7	3.8%	S1280 to Humboldt	XS631046>631122>\$1
635034	CLRND 5 161.0	560001	NODAWAYCO 161.0	1	153	146.4	146.7	3.8%	S1399 to Humboldt	XS635010>635011>\$1
635034	CLRND 5 161.0	560001	NODAWAYCO 161.0	1	153	146.4	146.7	3.8%	S1399 to Humboldt	XS631069>652560>\$1
635034	CLRND 5 161.0	560001	NODAWAYCO 161.0	1	153	146.5	146.7	3.8%	S975 (Humboldt) T4 161-69	XS659246>659247>\$1
635034	CLRND 5 161.0	560001	NODAWAYCO 161.0	1	153	146.5	146.7	3.8%	S975 (Humboldt) T4 161-69	XS652550>602009>\$1
635034	CLRND 5 161.0	560001	NODAWAYCO 161.0	1	153	146.4	146.7	3.8%	S975 (Humboldt) T4 161-69	XS652533>652289>\$1
635034	CLRND 5 161.0	560001	NODAWAYCO 161.0	1	153	146.5	146.7	3.8%	S975 (Humboldt) T4 161-69	XS650275>650284>\$1
635034	CLRND 5 161.0	560001	NODAWAYCO 161.0	1	153	146.4	146.7	3.8%	S975 (Humboldt) T4 161-69	XS659133>659135>\$1
635034	CLRND 5 161.0	560001	NODAWAYCO 161.0	1	153	146.4	146.7	3.8%	S975 (Humboldt) T4 161-69	XS652524>652235>\$1
635034	CLRND 5 161.0	560001	NODAWAYCO 161.0	1	153	146.4	146.7	3.8%	S975 (Humboldt) T4 161-69	XS652503>652530>\$1
635034	CLRND 5 161.0	560001	NODAWAYCO 161.0	1	153	146.5	146.7	3.8%	S975 (Humboldt) T4 161-69	XS652312>659241>\$1
635034	CLRND 5 161.0	560001	NODAWAYCO 161.0	1	153	146.5	146.7	3.8%	S975 (Humboldt) T4 161-69	XS652300>652301>\$1
635034	CLRND 5 161.0	560001	NODAWAYCO 161.0	1	153	146.5	146.7	3.8%	S975 (Humboldt) T4 161-69	XS636401>636678>\$1
635034	CLRND 5 161.0	560001	NODAWAYCO 161.0	1	153	146.5	146.7	3.8%	S975 (Humboldt) T4 161-69	XS635201>635225>\$1
635034	CLRND 5 161.0	560001	NODAWAYCO 161.0	1	153	146.5	146.7	3.8%	S975 (Humboldt) T4 161-69	XS635223>635225>\$1
635034	CLRND 5 161.0	560001	NODAWAYCO 161.0	1	153	146.5	146.7	3.8%	S975 (Humboldt) T4 161-69	XS636025>636030>\$1
635034	CLRND 5 161.0	560001	NODAWAYCO 161.0	1	153	146.5	146.7	3.8%	S975 (Humboldt) T4 161-69	XS635600>636010>\$1
635034	CLRND 5 161.0	560001	NODAWAYCO 161.0	1	153	146.5	146.7	3.8%	S975 (Humboldt) T4 161-69	XS635600>635700>\$2
635034	CLRND 5 161.0	560001	NODAWAYCO 161.0	1	153	146.5	146.7	3.8%	S975 (Humboldt) T4 161-69	XS635600>635700>\$1
635034	CLRND 5 161.0	560001	NODAWAYCO 161.0	1	153	146.5	146.7	3.8%	S975 (Humboldt) T4 161-69	XS635340>635350>\$1
635034	CLRND 5 161.0	560001	NODAWAYCO 161.0	1	153	146.5	146.7	3.8%	S975 (Humboldt) T4 161-69	XS640063>640064>\$1
635034	CLRND 5 161.0	560001	NODAWAYCO 161.0	1	153	146.4	146.7	3.8%	S975 (Humboldt) T4 161-69	XS636660>636661>\$1
635034	CLRND 5 161.0	560001	NODAWAYCO 161.0	1	153	146.4	146.7	3.8%	S975 (Humboldt) T4 161-69	XS636675>636677>\$1

635034	CLRND 5 161.0	560001	NODAWAYCO 161.0	1	153	146.5	146.7	3.8%	S975 (Humboldt) T4 161-69	XS640070>640300>\$1
635034	CLRND 5 161.0	560001	NODAWAYCO 161.0	1	153	146.5	146.7	3.8%	S975 (Humboldt) T4 161-69	XS640051>640367>\$1
635034	CLRND 5 161.0	560001	NODAWAYCO 161.0	1	153	146.5	146.7	3.8%	S975 (Humboldt) T4 161-69	XS640065>640312>\$1
635034	CLRND 5 161.0	560001	NODAWAYCO 161.0	1	153	146.5	146.7	3.8%	S975 (Humboldt) T4 161-69	XS640381>640382>\$1
635034	CLRND 5 161.0	560001	NODAWAYCO 161.0	1	153	146.4	146.7	3.8%	S975 (Humboldt) T4 161-69	XS640222>640223>\$1
635034	CLRND 5 161.0	560001	NODAWAYCO 161.0	1	153	146.5	146.7	3.8%	S975 (Humboldt) T4 161-69	XS640277>640278>640280\$1
635034	CLRND 5 161.0	560001	NODAWAYCO 161.0	1	153	146.4	146.7	3.8%	S975 (Humboldt) T4 161-69	XS641082>641091>\$1
635034	CLRND 5 161.0	560001	NODAWAYCO 161.0	1	153	146.4	146.7	3.8%	S975 (Humboldt) T4 161-69	XS640370>640371>\$1
635034	CLRND 5 161.0	560001	NODAWAYCO 161.0	1	153	146.4	146.7	3.8%	S975 (Humboldt) T4 161-69	XS640363>640364>\$1
635034	CLRND 5 161.0	560001	NODAWAYCO 161.0	1	153	146.4	146.7	3.8%	S975 (Humboldt) T4 161-69	XS640357>640358>\$1
635034	CLRND 5 161.0	560001	NODAWAYCO 161.0	1	153	146.5	146.7	3.8%	S975 (Humboldt) T4 161-69	XS640328>640329>\$1
635034	CLRND 5 161.0	560001	NODAWAYCO 161.0	1	153	146.4	146.7	3.8%	S975 (Humboldt) T4 161-69	XS640263>640264>\$1
635034	CLRND 5 161.0	560001	NODAWAYCO 161.0	1	153	146.4	146.7	3.8%	S975 (Humboldt) T4 161-69	XS640386>652565>\$1
635034	CLRND 5 161.0	560001	NODAWAYCO 161.0	1	153	146.5	146.7	3.8%	S975 (Humboldt) T4 161-69	XS640387>640389>\$1
635034	CLRND 5 161.0	560001	NODAWAYCO 161.0	1	153	146.4	146.7	3.8%	S975 (Humboldt) T4 161-69	XS640411>640443>\$1
635034	CLRND 5 161.0	560001	NODAWAYCO 161.0	1	153	146.5	146.7	3.8%	S975 (Humboldt) T4 161-69	XS640402>648402>\$1
635034	CLRND 5 161.0	560001	NODAWAYCO 161.0	1	153	146.4	146.7	3.8%	S975 (Humboldt) T4 161-69	XS640281>648401>\$1
635034	CLRND 5 161.0	560001	NODAWAYCO 161.0	1	153	146.5	146.7	3.8%	S975 (Humboldt) T4 161-69	XS640426>640427>\$1
635034	CLRND 5 161.0	560001	NODAWAYCO 161.0	1	153	146.5	146.7	3.8%	S975 (Humboldt) T4 161-69	XS640235>640236>\$1
635034	CLRND 5 161.0	560001	NODAWAYCO 161.0	1	153	146.4	146.7	3.8%	S975 (Humboldt) T4 161-69	XS640278>640279>\$1
635034	CLRND 5 161.0	560001	NODAWAYCO 161.0	1	153	146.5	146.7	3.8%	S975 (Humboldt) T4 161-69	XS300056>505438>\$1
635034	CLRND 5 161.0	560001	NODAWAYCO 161.0	1	153	146.4	146.7	3.8%	S975 (Humboldt) T4 161-69	XS300040>300047>\$1
635034	CLRND 5 161.0	560001	NODAWAYCO 161.0	1	153	146.4	146.7	3.8%	S975 (Humboldt) T4 161-69	S991TAP
635034	CLRND 5 161.0	560001	NODAWAYCO 161.0	1	153	146.5	146.7	3.8%	S975 (Humboldt) T4 161-69	XS300038>344974>\$1

635034	CLRNDA 5 161.0	560001	NODAWAYCO 161.0	1	153	146.5	146.7	3.8%	S975 (Humboldt) T4 161-69	XS300063>344233>\$1
635034	CLRNDA 5 161.0	560001	NODAWAYCO 161.0	1	153	146.4	146.7	3.8%	S975 (Humboldt) T4 161-69	XS300077>345798>\$1
635034	CLRNDA 5 161.0	560001	NODAWAYCO 161.0	1	153	146.4	146.7	3.8%	S975 (Humboldt) T4 161-69	MC1235-31-34
635034	CLRNDA 5 161.0	560001	NODAWAYCO 161.0	1	153	146.5	146.7	3.8%	S975 (Humboldt) T4 161-69	XS300063>300550>\$1
635034	CLRNDA 5 161.0	560001	NODAWAYCO 161.0	1	153	146.5	146.7	3.8%	S975 (Humboldt) T4 161-69	XS300071>505502>\$1
635034	CLRNDA 5 161.0	560001	NODAWAYCO 161.0	1	153	146.5	146.7	3.8%	S975 (Humboldt) T4 161-69	XS300075>505434>\$1
635034	CLRNDA 5 161.0	560001	NODAWAYCO 161.0	1	153	146.5	146.7	3.8%	S975 (Humboldt) T4 161-69	S968LINBUS
635034	CLRNDA 5 161.0	560001	NODAWAYCO 161.0	1	153	146.4	146.7	3.8%	S975 (Humboldt) T4 161-69	S1206T2 BSCL
635034	CLRNDA 5 161.0	560001	NODAWAYCO 161.0	1	153	146.4	146.7	3.8%	S975 (Humboldt) T4 161-69	XS300056>505434>\$1
635034	CLRNDA 5 161.0	560001	NODAWAYCO 161.0	1	153	146.5	146.7	3.8%	S975 (Humboldt) T4 161-69	XS300081>505460>\$1
635034	CLRNDA 5 161.0	560001	NODAWAYCO 161.0	1	153	146.5	146.7	3.8%	S975 (Humboldt) T4 161-69	XS300136>514906>\$1
635034	CLRNDA 5 161.0	560001	NODAWAYCO 161.0	1	153	146.5	146.7	3.8%	S975 (Humboldt) T4 161-69	XS300084>301211>\$1
635034	CLRNDA 5 161.0	560001	NODAWAYCO 161.0	1	153	146.5	146.7	3.8%	S975 (Humboldt) T4 161-69	XS300917>301128>\$1
635034	CLRNDA 5 161.0	560001	NODAWAYCO 161.0	1	153	146.4	146.7	3.8%	S975 (Humboldt) T4 161-69	XS300088>300102>\$1
635034	CLRNDA 5 161.0	560001	NODAWAYCO 161.0	1	153	146.5	146.7	3.8%	S975 (Humboldt) T4 161-69	XS301144>344360>\$1
635034	CLRNDA 5 161.0	560001	NODAWAYCO 161.0	1	153	146.5	146.7	3.8%	S975 (Humboldt) T4 161-69	XS532912>533238>532940\$1
635034	CLRNDA 5 161.0	560001	NODAWAYCO 161.0	1	153	146.5	146.7	3.8%	S975 (Humboldt) T4 161-69	XS532912>546742>\$1
635034	CLRNDA 5 161.0	560001	NODAWAYCO 161.0	1	153	146.5	146.7	3.8%	S975 (Humboldt) T4 161-69	XS532851>532856>\$1
635034	CLRNDA 5 161.0	560001	NODAWAYCO 161.0	1	153	146.5	146.7	3.8%	S975 (Humboldt) T4 161-69	XS532794>514803>\$1
635034	CLRNDA 5 161.0	560001	NODAWAYCO 161.0	1	153	146.5	146.7	3.8%	S975 (Humboldt) T4 161-69	XS646201>646286>\$1
635034	CLRNDA 5 161.0	560001	NODAWAYCO 161.0	1	153	146.5	146.7	3.8%	S975 (Humboldt) T4 161-69	XS650267>650284>\$1
635034	CLRNDA 5 161.0	560001	NODAWAYCO 161.0	1	153	146.5	146.7	3.8%	S975 (Humboldt) T4 161-69	XS646209>646252>\$1
635034	CLRNDA 5 161.0	560001	NODAWAYCO 161.0	1	153	146.4	146.7	3.8%	S975 (Humboldt) T4 161-69	XS647090>647990>\$1
635034	CLRNDA 5 161.0	560001	NODAWAYCO 161.0	1	153	146.4	146.7	3.8%	S975 (Humboldt) T4 161-69	XS647909>647937>\$1

635034	CLRNDA 5 161.0	560001	NODAWAYCO 161.0	1	153	146.5	146.7	3.8%	S975 (Humboldt) T4 161-69	XS647907>647919>\$1
635034	CLRNDA 5 161.0	560001	NODAWAYCO 161.0	1	153	146.4	146.7	3.8%	S975 (Humboldt) T4 161-69	XS631094>629098>\$1
635034	CLRNDA 5 161.0	560001	NODAWAYCO 161.0	1	153	146.5	146.7	3.8%	S975 (Humboldt) T4 161-69	XS631036>631174>\$1
635034	CLRNDA 5 161.0	560001	NODAWAYCO 161.0	1	153	146.4	146.7	3.8%	S975 (Humboldt) T4 161-69	XS631109>347840>\$1
635034	CLRNDA 5 161.0	560001	NODAWAYCO 161.0	1	153	146.5	146.7	3.8%	S975 (Humboldt) T4 161-69	XS631073>631099>\$1
635034	CLRNDA 5 161.0	560001	NODAWAYCO 161.0	1	153	146.5	146.7	3.8%	S975 (Humboldt) T4 161-69	XS631041>631042>\$1
635034	CLRNDA 5 161.0	560001	NODAWAYCO 161.0	1	153	146.4	146.7	3.8%	S975 (Humboldt) T4 161-69	XS631048>636300>\$1
635034	CLRNDA 5 161.0	560001	NODAWAYCO 161.0	1	153	146.4	146.7	3.8%	S975 (Humboldt) T4 161-69	XS631083>631086>\$1
635034	CLRNDA 5 161.0	560001	NODAWAYCO 161.0	1	153	146.5	146.7	3.8%	S975 (Humboldt) T4 161-69	XS631110>630048>\$2
635034	CLRNDA 5 161.0	560001	NODAWAYCO 161.0	1	153	146.5	146.7	3.8%	S975 (Humboldt) T4 161-69	XS631144>601002>\$1
635034	CLRNDA 5 161.0	560001	NODAWAYCO 161.0	1	153	146.5	146.7	3.8%	S975 (Humboldt) T4 161-69	XS631056>631060>\$1
635034	CLRNDA 5 161.0	560001	NODAWAYCO 161.0	1	153	146.5	146.7	3.8%	S975 (Humboldt) T4 161-69	XS631110>630048>\$1
635034	CLRNDA 5 161.0	560001	NODAWAYCO 161.0	1	153	146.5	146.7	3.8%	S975 (Humboldt) T4 161-69	XS533371>533381>\$1
635034	CLRNDA 5 161.0	560001	NODAWAYCO 161.0	1	153	146.5	146.7	3.8%	S975 (Humboldt) T4 161-69	XS533345>533347>\$1
635034	CLRNDA 5 161.0	560001	NODAWAYCO 161.0	1	153	146.5	146.7	3.8%	S975 (Humboldt) T4 161-69	XS541218>541313>\$1
635034	CLRNDA 5 161.0	560001	NODAWAYCO 161.0	1	153	146.4	146.7	3.8%	S975 (Humboldt) T4 161-69	XS533322>533337>\$1
635034	CLRNDA 5 161.0	560001	NODAWAYCO 161.0	1	153	146.5	146.7	3.8%	S975 (Humboldt) T4 161-69	XS541205>541237>\$1
635034	CLRNDA 5 161.0	560001	NODAWAYCO 161.0	1	153	146.5	146.7	3.8%	S975 (Humboldt) T4 161-69	XS533440>533455>\$1
635034	CLRNDA 5 161.0	560001	NODAWAYCO 161.0	1	153	146.5	146.7	3.8%	S975 (Humboldt) T4 161-69	XS541203>541204>\$1
635034	CLRNDA 5 161.0	560001	NODAWAYCO 161.0	1	153	146.4	146.7	3.8%	S975 (Humboldt) T4 161-69	XS533261>533282>\$1
635034	CLRNDA 5 161.0	560001	NODAWAYCO 161.0	1	153	146.5	146.7	3.8%	S975 (Humboldt) T4 161-69	XS543031>543041>\$1
635034	CLRNDA 5 161.0	560001	NODAWAYCO 161.0	1	153	146.5	146.7	3.8%	S975 (Humboldt) T4 161-69	XS543060>543061>\$1
635034	CLRNDA 5 161.0	560001	NODAWAYCO 161.0	1	153	146.5	146.7	3.8%	S975 (Humboldt) T4 161-69	XS543002>541210>\$1
635034	CLRNDA 5 161.0	560001	NODAWAYCO 161.0	1	153	146.5	146.7	3.8%	S975 (Humboldt) T4 161-69	XS543038>543052>\$1

635034	CLRND 5 161.0	560001	NODAWAYCO 161.0	1	153	146.5	146.7	3.8%	S975 (Humboldt) T4 161-69	XS542979>543047>\$1
635034	CLRND 5 161.0	560001	NODAWAYCO 161.0	1	153	146.5	146.7	3.8%	S975 (Humboldt) T4 161-69	XS542968>542969>543648\$22
635034	CLRND 5 161.0	560001	NODAWAYCO 161.0	1	153	146.5	146.7	3.8%	S975 (Humboldt) T4 161-69	XS541259>541340>\$1
635034	CLRND 5 161.0	560001	NODAWAYCO 161.0	1	153	146.5	146.7	3.8%	S975 (Humboldt) T4 161-69	XS542968>542969>543647\$11
635034	CLRND 5 161.0	560001	NODAWAYCO 161.0	1	153	146.5	146.7	3.8%	S975 (Humboldt) T4 161-69	XS542966>543044>\$1
635034	CLRND 5 161.0	560001	NODAWAYCO 161.0	1	153	146.5	146.7	3.8%	S975 (Humboldt) T4 161-69	LES0010A
635034	CLRND 5 161.0	560001	NODAWAYCO 161.0	1	153	146.5	146.7	3.8%	S975 (Humboldt) T4 161-69	CB906N69B916
635034	CLRND 5 161.0	560001	NODAWAYCO 161.0	1	153	146.5	146.7	3.8%	S975 (Humboldt) T4 161-69	CB1206-32&01
635034	CLRND 5 161.0	560001	NODAWAYCO 161.0	1	153	146.5	146.7	3.8%	S975 (Humboldt) T4 161-69	CB968-67-TEC
635034	CLRND 5 161.0	560001	NODAWAYCO 161.0	1	153	146.3	146.6	4.8%	S1399 to Humboldt	XS635001>635011>\$1
635034	CLRND 5 161.0	560001	NODAWAYCO 161.0	1	153	146.3	146.6	4.8%	S1399 to Humboldt	XS631138>635200>\$1
635034	CLRND 5 161.0	560001	NODAWAYCO 161.0	1	153	146.2	146.6	4.8%	S1399 to Humboldt	S938LINBUS
635034	CLRND 5 161.0	560001	NODAWAYCO 161.0	1	153	146.3	146.6	4.8%	S1399 to Humboldt	XS300041>300042>\$1
635034	CLRND 5 161.0	560001	NODAWAYCO 161.0	1	153	146.3	146.6	4.8%	S1399 to Humboldt	XS532768>532744>\$1
635034	CLRND 5 161.0	560001	NODAWAYCO 161.0	1	153	146.3	146.6	4.8%	S1399 to Humboldt	XS532768>532743>\$1
635034	CLRND 5 161.0	560001	NODAWAYCO 161.0	1	153	146.3	146.6	4.8%	S1399 to Humboldt	XS532768>532742>\$1
635034	CLRND 5 161.0	560001	NODAWAYCO 161.0	1	153	146.3	146.6	4.8%	S1399 to Humboldt	CBRAUN-LF-LH
635034	CLRND 5 161.0	560001	NODAWAYCO 161.0	1	153	146.3	146.6	4.8%	S1399 to Humboldt	CB1256-49&53
635034	CLRND 5 161.0	560001	NODAWAYCO 161.0	1	153	146.3	146.6	4.8%	S1399 to Humboldt	CB1222-BUS
635034	CLRND 5 161.0	560001	NODAWAYCO 161.0	1	153	146.2	146.6	4.8%	S1399 to Humboldt	CB1229-BUS
635034	CLRND 5 161.0	560001	NODAWAYCO 161.0	1	153	146.2	146.6	4.8%	S1399 to Humboldt	XS542973>542967>\$1
635034	CLRND 5 161.0	560001	NODAWAYCO 161.0	1	153	146.3	146.6	3.8%	S1280 to Humboldt	XS635610>635612>\$1
635034	CLRND 5 161.0	560001	NODAWAYCO 161.0	1	153	146.3	146.6	3.8%	S1280 to Humboldt	XS635613>635631>\$1
635034	CLRND 5 161.0	560001	NODAWAYCO 161.0	1	153	146.3	146.6	3.8%	S1280 to Humboldt	XS635612>635613>\$1
635034	CLRND 5 161.0	560001	NODAWAYCO 161.0	1	153	146.4	146.6	3.8%	S1280 to Humboldt	XS635610>635662>\$1
635034	CLRND 5 161.0	560001	NODAWAYCO 161.0	1	153	146.4	146.6	3.8%	S1280 to Humboldt	XS635610>635616>\$1

635034	CLRNDA 5	161.0	560001	NODAWAYCO	161.0	1	153	146.4	146.6	3.8%	S1280 to Humboldt	XS635672>635673>\$1
635034	CLRNDA 5	161.0	560001	NODAWAYCO	161.0	1	153	146.4	146.6	3.8%	S1280 to Humboldt	XS636001>656353>\$1
635034	CLRNDA 5	161.0	560001	NODAWAYCO	161.0	1	153	146.4	146.6	3.8%	S1280 to Humboldt	XS635221>635226>\$1
635034	CLRNDA 5	161.0	560001	NODAWAYCO	161.0	1	153	146.3	146.6	3.8%	S1280 to Humboldt	XS635607>635710>\$1
635034	CLRNDA 5	161.0	560001	NODAWAYCO	161.0	1	153	146.4	146.6	3.8%	S1280 to Humboldt	XS635605>635614>\$1
635034	CLRNDA 5	161.0	560001	NODAWAYCO	161.0	1	153	146.4	146.6	3.8%	S1280 to Humboldt	XS636001>656369>\$1
635034	CLRNDA 5	161.0	560001	NODAWAYCO	161.0	1	153	146.3	146.6	3.8%	S1280 to Humboldt	XS631100>631101>\$1
635034	CLRNDA 5	161.0	560001	NODAWAYCO	161.0	1	153	146.4	146.6	3.8%	S1280 to Humboldt	XS635201>635225>\$1
635034	CLRNDA 5	161.0	560001	NODAWAYCO	161.0	1	153	146.4	146.6	3.8%	S1280 to Humboldt	XS631122>681537>\$1
635034	CLRNDA 5	161.0	560001	NODAWAYCO	161.0	1	153	146.4	146.6	3.8%	S1280 to Humboldt	XS635651>635670>\$1
635034	CLRNDA 5	161.0	560001	NODAWAYCO	161.0	1	153	146.4	146.6	3.8%	S1280 to Humboldt	XS635651>635670>\$2
635034	CLRNDA 5	161.0	560001	NODAWAYCO	161.0	1	153	146.4	146.6	3.8%	S1280 to Humboldt	XS635039>635040>\$1
635034	CLRNDA 5	161.0	560001	NODAWAYCO	161.0	1	153	146.3	146.6	3.8%	S1280 to Humboldt	XS636030>636031>636032\$1
635034	CLRNDA 5	161.0	560001	NODAWAYCO	161.0	1	153	146.4	146.6	3.8%	S1280 to Humboldt	XS635280>635340>\$1
635034	CLRNDA 5	161.0	560001	NODAWAYCO	161.0	1	153	146.4	146.6	3.8%	S1280 to Humboldt	XS635630>635635>\$1
635034	CLRNDA 5	161.0	560001	NODAWAYCO	161.0	1	153	146.3	146.6	3.8%	S1280 to Humboldt	XS636675>636676>\$1
635034	CLRNDA 5	161.0	560001	NODAWAYCO	161.0	1	153	146.4	146.6	3.8%	S1280 to Humboldt	XS636673>633261>\$1
635034	CLRNDA 5	161.0	560001	NODAWAYCO	161.0	1	153	146.4	146.6	3.8%	S1280 to Humboldt	XS636691>636693>\$1
635034	CLRNDA 5	161.0	560001	NODAWAYCO	161.0	1	153	146.4	146.6	3.8%	S1280 to Humboldt	XS640100>640194>\$1
635034	CLRNDA 5	161.0	560001	NODAWAYCO	161.0	1	153	146.4	146.6	3.8%	S1280 to Humboldt	XS636670>636673>\$1
635034	CLRNDA 5	161.0	560001	NODAWAYCO	161.0	1	153	146.4	146.6	3.8%	S1280 to Humboldt	XS640102>640103>643029\$1
635034	CLRNDA 5	161.0	560001	NODAWAYCO	161.0	1	153	146.3	146.6	3.8%	S1280 to Humboldt	XS640100>640101>\$1
635034	CLRNDA 5	161.0	560001	NODAWAYCO	161.0	1	153	146.4	146.6	3.8%	S1280 to Humboldt	XS640155>640156>\$1
635034	CLRNDA 5	161.0	560001	NODAWAYCO	161.0	1	153	146.4	146.6	3.8%	S1280 to Humboldt	XS640091>640092>\$1
635034	CLRNDA 5	161.0	560001	NODAWAYCO	161.0	1	153	146.4	146.6	3.8%	S1280 to Humboldt	XS636690>636691>\$1
635034	CLRNDA 5	161.0	560001	NODAWAYCO	161.0	1	153	146.4	146.6	3.8%	S1280 to Humboldt	XS640167>659130>\$1
635034	CLRNDA 5	161.0	560001	NODAWAYCO	161.0	1	153	146.4	146.6	3.8%	S1280 to Humboldt	XS640093>640330>\$1

635034	CLRNDA 5	161.0	560001	NODAWAYCO	161.0	1	153	146.4	146.6	3.8%	S1280 to Humboldt	XS640093>640102>\$1
635034	CLRNDA 5	161.0	560001	NODAWAYCO	161.0	1	153	146.4	146.6	3.8%	S1280 to Humboldt	XS640153>640174>\$1
635034	CLRNDA 5	161.0	560001	NODAWAYCO	161.0	1	153	146.4	146.6	3.8%	S1280 to Humboldt	XS640105>640106>\$1
635034	CLRNDA 5	161.0	560001	NODAWAYCO	161.0	1	153	146.3	146.6	3.8%	S1280 to Humboldt	XS640086>640087>\$1
635034	CLRNDA 5	161.0	560001	NODAWAYCO	161.0	1	153	146.4	146.6	3.8%	S1280 to Humboldt	XS640072>640296>\$1
635034	CLRNDA 5	161.0	560001	NODAWAYCO	161.0	1	153	146.3	146.6	3.8%	S1280 to Humboldt	XS640165>640305>\$1
635034	CLRNDA 5	161.0	560001	NODAWAYCO	161.0	1	153	146.4	146.6	3.8%	S1280 to Humboldt	XS640058>640367>\$1
635034	CLRNDA 5	161.0	560001	NODAWAYCO	161.0	1	153	146.4	146.6	3.8%	S1280 to Humboldt	XS636640>636645>\$1
635034	CLRNDA 5	161.0	560001	NODAWAYCO	161.0	1	153	146.4	146.6	3.8%	S1280 to Humboldt	XS640056>640323>\$1
635034	CLRNDA 5	161.0	560001	NODAWAYCO	161.0	1	153	146.4	146.6	3.8%	S1280 to Humboldt	XS640051>640367>\$1
635034	CLRNDA 5	161.0	560001	NODAWAYCO	161.0	1	153	146.4	146.6	3.8%	S1280 to Humboldt	XS640058>640165>\$1
635034	CLRNDA 5	161.0	560001	NODAWAYCO	161.0	1	153	146.3	146.6	3.8%	S1280 to Humboldt	XS640054>640347>\$1
635034	CLRNDA 5	161.0	560001	NODAWAYCO	161.0	1	153	146.4	146.6	3.8%	S1280 to Humboldt	XS640178>640272>\$1
635034	CLRNDA 5	161.0	560001	NODAWAYCO	161.0	1	153	146.4	146.6	3.8%	S1280 to Humboldt	XS640133>652509>\$1
635034	CLRNDA 5	161.0	560001	NODAWAYCO	161.0	1	153	146.4	146.6	3.8%	S1280 to Humboldt	XS640133>640343>\$1
635034	CLRNDA 5	161.0	560001	NODAWAYCO	161.0	1	153	146.4	146.6	3.8%	S1280 to Humboldt	XS636300>656087>\$1
635034	CLRNDA 5	161.0	560001	NODAWAYCO	161.0	1	153	146.3	146.6	3.8%	S1280 to Humboldt	XS640147>640148>\$1
635034	CLRNDA 5	161.0	560001	NODAWAYCO	161.0	1	153	146.4	146.6	3.8%	S1280 to Humboldt	XS640136>640345>\$1
635034	CLRNDA 5	161.0	560001	NODAWAYCO	161.0	1	153	146.3	146.6	3.8%	S1280 to Humboldt	XS636240>636241>\$1
635034	CLRNDA 5	161.0	560001	NODAWAYCO	161.0	1	153	146.4	146.6	3.8%	S1280 to Humboldt	XS636615>636616>636619\$1
635034	CLRNDA 5	161.0	560001	NODAWAYCO	161.0	1	153	146.4	146.6	3.8%	S1280 to Humboldt	XS636615>636620>\$1
635034	CLRNDA 5	161.0	560001	NODAWAYCO	161.0	1	153	146.4	146.6	3.8%	S1280 to Humboldt	XS640117>640394>\$1
635034	CLRNDA 5	161.0	560001	NODAWAYCO	161.0	1	153	146.4	146.6	3.8%	S1280 to Humboldt	XS640111>640112>\$1
635034	CLRNDA 5	161.0	560001	NODAWAYCO	161.0	1	153	146.3	146.6	3.8%	S1280 to Humboldt	XS640173>640281>\$1
635034	CLRNDA 5	161.0	560001	NODAWAYCO	161.0	1	153	146.4	146.6	3.8%	S1280 to Humboldt	XS640174>640178>\$1
635034	CLRNDA 5	161.0	560001	NODAWAYCO	161.0	1	153	146.4	146.6	3.8%	S1280 to Humboldt	XS640174>640175>\$1
635034	CLRNDA 5	161.0	560001	NODAWAYCO	161.0	1	153	146.4	146.6	3.8%	S1280 to Humboldt	XS640284>640347>\$1

635034	CLRNDA 5	161.0	560001	NODAWAYCO	161.0	1	153	146.3	146.6	3.8%	S1280 to Humboldt	XS640281>648400>\$1
635034	CLRNDA 5	161.0	560001	NODAWAYCO	161.0	1	153	146.4	146.6	3.8%	S1280 to Humboldt	XS640281>640336>\$1
635034	CLRNDA 5	161.0	560001	NODAWAYCO	161.0	1	153	146.4	146.6	3.8%	S1280 to Humboldt	XS645061>648500>\$1
635034	CLRNDA 5	161.0	560001	NODAWAYCO	161.0	1	153	146.4	146.6	3.8%	S1280 to Humboldt	XS640293>640444>\$1
635034	CLRNDA 5	161.0	560001	NODAWAYCO	161.0	1	153	146.3	146.6	3.8%	S1280 to Humboldt	XS645001>645102>\$1
635034	CLRNDA 5	161.0	560001	NODAWAYCO	161.0	1	153	146.4	146.6	3.8%	S1280 to Humboldt	XS640261>640321>\$1
635034	CLRNDA 5	161.0	560001	NODAWAYCO	161.0	1	153	146.4	146.6	3.8%	S1280 to Humboldt	XS645021>645121>\$1
635034	CLRNDA 5	161.0	560001	NODAWAYCO	161.0	1	153	146.4	146.6	3.8%	S1280 to Humboldt	XS640271>652571>\$1
635034	CLRNDA 5	161.0	560001	NODAWAYCO	161.0	1	153	146.4	146.6	3.8%	S1280 to Humboldt	XS640222>640224>\$1
635034	CLRNDA 5	161.0	560001	NODAWAYCO	161.0	1	153	146.4	146.6	3.8%	S1280 to Humboldt	XS640235>640236>\$1
635034	CLRNDA 5	161.0	560001	NODAWAYCO	161.0	1	153	146.3	146.6	3.8%	S1280 to Humboldt	XS645128>646211>\$1
635034	CLRNDA 5	161.0	560001	NODAWAYCO	161.0	1	153	146.3	146.6	3.8%	S1280 to Humboldt	XS640368>640369>\$1
635034	CLRNDA 5	161.0	560001	NODAWAYCO	161.0	1	153	146.3	146.6	3.8%	S1280 to Humboldt	XS640334>640335>643130\$1
635034	CLRNDA 5	161.0	560001	NODAWAYCO	161.0	1	153	146.3	146.6	3.8%	S1280 to Humboldt	XS645127>646211>\$1
635034	CLRNDA 5	161.0	560001	NODAWAYCO	161.0	1	153	146.3	146.6	3.8%	S1280 to Humboldt	XS640378>640379>\$1
635034	CLRNDA 5	161.0	560001	NODAWAYCO	161.0	1	153	146.3	146.6	3.8%	S1280 to Humboldt	XS645126>647911>\$1
635034	CLRNDA 5	161.0	560001	NODAWAYCO	161.0	1	153	146.4	146.6	3.8%	S1280 to Humboldt	XS640349>640350>\$1
635034	CLRNDA 5	161.0	560001	NODAWAYCO	161.0	1	153	146.4	146.6	3.8%	S1280 to Humboldt	XS640206>640313>\$1
635034	CLRNDA 5	161.0	560001	NODAWAYCO	161.0	1	153	146.4	146.6	3.8%	S1280 to Humboldt	XS645451>645454>\$1
635034	CLRNDA 5	161.0	560001	NODAWAYCO	161.0	1	153	146.4	146.6	3.8%	S1280 to Humboldt	XS640342>640343>643136\$1
635034	CLRNDA 5	161.0	560001	NODAWAYCO	161.0	1	153	146.4	146.6	3.8%	S1280 to Humboldt	XS640302>659134>\$1
635034	CLRNDA 5	161.0	560001	NODAWAYCO	161.0	1	153	146.4	146.6	3.8%	S1280 to Humboldt	XS640302>659132>643115\$1
635034	CLRNDA 5	161.0	560001	NODAWAYCO	161.0	1	153	146.4	146.6	3.8%	S1280 to Humboldt	XS640312>640313>640315\$1
635034	CLRNDA 5	161.0	560001	NODAWAYCO	161.0	1	153	146.3	146.6	3.8%	S1280 to Humboldt	XS640318>640319>\$1
635034	CLRNDA 5	161.0	560001	NODAWAYCO	161.0	1	153	146.4	146.6	3.8%	S1280 to Humboldt	XS645100>645103>\$1
635034	CLRNDA 5	161.0	560001	NODAWAYCO	161.0	1	153	146.4	146.6	3.8%	S1280 to Humboldt	XS640394>640395>\$1
635034	CLRNDA 5	161.0	560001	NODAWAYCO	161.0	1	153	146.4	146.6	3.8%	S1280 to Humboldt	XS640300>640400>\$1

635034	CLRND 5	161.0	560001	NODAWAYCO	161.0	1	153	146.3	146.6	3.8%	S1280 to Humboldt	XS640392>640394>\$1
635034	CLRND 5	161.0	560001	NODAWAYCO	161.0	1	153	146.4	146.6	3.8%	S1280 to Humboldt	XS640183>640252>\$1
635034	CLRND 5	161.0	560001	NODAWAYCO	161.0	1	153	146.4	146.6	3.8%	S1280 to Humboldt	XS647424>647976>\$1
635034	CLRND 5	161.0	560001	NODAWAYCO	161.0	1	153	146.4	146.6	3.8%	S1280 to Humboldt	XS647006>647928>\$1
635034	CLRND 5	161.0	560001	NODAWAYCO	161.0	1	153	146.3	146.6	3.8%	S1280 to Humboldt	XS647874>647995>\$1
635034	CLRND 5	161.0	560001	NODAWAYCO	161.0	1	153	146.3	146.6	3.8%	S1280 to Humboldt	XS650242>650342>650542\$1
635034	CLRND 5	161.0	560001	NODAWAYCO	161.0	1	153	146.4	146.6	3.8%	S1280 to Humboldt	XS647902>647984>\$1
635034	CLRND 5	161.0	560001	NODAWAYCO	161.0	1	153	146.4	146.6	3.8%	S1280 to Humboldt	XS646211>647911>648211\$1
635034	CLRND 5	161.0	560001	NODAWAYCO	161.0	1	153	146.4	146.6	3.8%	S1280 to Humboldt	XS647907>647911>\$1
635034	CLRND 5	161.0	560001	NODAWAYCO	161.0	1	153	146.4	146.6	3.8%	S1280 to Humboldt	XS646286>646299>\$1
635034	CLRND 5	161.0	560001	NODAWAYCO	161.0	1	153	146.3	146.6	3.8%	S1280 to Humboldt	XS647006>647079>\$1
635034	CLRND 5	161.0	560001	NODAWAYCO	161.0	1	153	146.4	146.6	3.8%	S1280 to Humboldt	XS647900>647972>\$1
635034	CLRND 5	161.0	560001	NODAWAYCO	161.0	1	153	146.4	146.6	3.8%	S1280 to Humboldt	XS647901>647912>\$1
635034	CLRND 5	161.0	560001	NODAWAYCO	161.0	1	153	146.3	146.6	3.8%	S1280 to Humboldt	XS646206>646232>\$1
635034	CLRND 5	161.0	560001	NODAWAYCO	161.0	1	153	146.4	146.6	3.8%	S1280 to Humboldt	XS646399>648500>648501\$1
635034	CLRND 5	161.0	560001	NODAWAYCO	161.0	1	153	146.4	146.6	3.8%	S1280 to Humboldt	XS647106>647923>\$1
635034	CLRND 5	161.0	560001	NODAWAYCO	161.0	1	153	146.4	146.6	3.8%	S1280 to Humboldt	XS650261>650361>650561\$1
635034	CLRND 5	161.0	560001	NODAWAYCO	161.0	1	153	146.3	146.6	3.8%	S1280 to Humboldt	XS650261>650269>\$1
635034	CLRND 5	161.0	560001	NODAWAYCO	161.0	1	153	146.4	146.6	3.8%	S1280 to Humboldt	XS650262>650267>\$1
635034	CLRND 5	161.0	560001	NODAWAYCO	161.0	1	153	146.4	146.6	3.8%	S1280 to Humboldt	XS650271>650285>\$1
635034	CLRND 5	161.0	560001	NODAWAYCO	161.0	1	153	146.3	146.6	3.8%	S1280 to Humboldt	XS647902>647937>\$1
635034	CLRND 5	161.0	560001	NODAWAYCO	161.0	1	153	146.3	146.6	3.8%	S1280 to Humboldt	XS646231>646235>\$1
635034	CLRND 5	161.0	560001	NODAWAYCO	161.0	1	153	146.3	146.6	3.8%	S1280 to Humboldt	XS647112>647964>\$1
635034	CLRND 5	161.0	560001	NODAWAYCO	161.0	1	153	146.4	146.6	3.8%	S1280 to Humboldt	XS647400>647968>\$1
635034	CLRND 5	161.0	560001	NODAWAYCO	161.0	1	153	146.3	146.6	3.8%	S1280 to Humboldt	XS647112>647993>\$1
635034	CLRND 5	161.0	560001	NODAWAYCO	161.0	1	153	146.4	146.6	3.8%	S1280 to Humboldt	XS647079>647900>\$1
635034	CLRND 5	161.0	560001	NODAWAYCO	161.0	1	153	146.3	146.6	3.8%	S1280 to Humboldt	XS646201>646220>\$1

635034	CLRNDA 5	161.0	560001	NODAWAYCO	161.0	1	153	146.3	146.6	3.8%	S1280 to Humboldt	XS646211>646220>\$1
635034	CLRNDA 5	161.0	560001	NODAWAYCO	161.0	1	153	146.4	146.6	3.8%	S1280 to Humboldt	XS646209>646250>\$1
635034	CLRNDA 5	161.0	560001	NODAWAYCO	161.0	1	153	146.4	146.6	3.8%	S1280 to Humboldt	XS652311>659236>\$1
635034	CLRNDA 5	161.0	560001	NODAWAYCO	161.0	1	153	146.4	146.6	3.8%	S1280 to Humboldt	XS647919>647930>\$1
635034	CLRNDA 5	161.0	560001	NODAWAYCO	161.0	1	153	146.4	146.6	3.8%	S1280 to Humboldt	XS647919>647950>\$1
635034	CLRNDA 5	161.0	560001	NODAWAYCO	161.0	1	153	146.4	146.6	3.8%	S1280 to Humboldt	XS646209>646231>\$2
635034	CLRNDA 5	161.0	560001	NODAWAYCO	161.0	1	153	146.3	146.6	3.8%	S1280 to Humboldt	XS650215>650261>\$1
635034	CLRNDA 5	161.0	560001	NODAWAYCO	161.0	1	153	146.3	146.6	3.8%	S1280 to Humboldt	XS646211>646250>\$1
635034	CLRNDA 5	161.0	560001	NODAWAYCO	161.0	1	153	146.4	146.6	3.8%	S1280 to Humboldt	XS650205>650215>\$1
635034	CLRNDA 5	161.0	560001	NODAWAYCO	161.0	1	153	146.4	146.6	3.8%	S1280 to Humboldt	XS650205>650212>\$1
635034	CLRNDA 5	161.0	560001	NODAWAYCO	161.0	1	153	146.4	146.6	3.8%	S1280 to Humboldt	XS646209>646250>\$2
635034	CLRNDA 5	161.0	560001	NODAWAYCO	161.0	1	153	146.3	146.6	3.8%	S1280 to Humboldt	XS647964>647975>\$1
635034	CLRNDA 5	161.0	560001	NODAWAYCO	161.0	1	153	146.4	146.6	3.8%	S1280 to Humboldt	XS646250>647950>648250\$1
635034	CLRNDA 5	161.0	560001	NODAWAYCO	161.0	1	153	146.3	146.6	3.8%	S1280 to Humboldt	XS646210>646222>\$1
635034	CLRNDA 5	161.0	560001	NODAWAYCO	161.0	1	153	146.3	146.6	3.8%	S1280 to Humboldt	XS646259>646281>\$1
635034	CLRNDA 5	161.0	560001	NODAWAYCO	161.0	1	153	146.3	146.6	3.8%	S1280 to Humboldt	XS646211>646250>\$2
635034	CLRNDA 5	161.0	560001	NODAWAYCO	161.0	1	153	146.4	146.6	3.8%	S1280 to Humboldt	XS646211>646299>\$1
635034	CLRNDA 5	161.0	560001	NODAWAYCO	161.0	1	153	146.4	146.6	3.8%	S1280 to Humboldt	XS650226>650326>650526\$1
635034	CLRNDA 5	161.0	560001	NODAWAYCO	161.0	1	153	146.4	146.6	3.8%	S1280 to Humboldt	XS646209>646231>\$1
635034	CLRNDA 5	161.0	560001	NODAWAYCO	161.0	1	153	146.4	146.6	3.8%	S1280 to Humboldt	XS646235>646236>\$1
635034	CLRNDA 5	161.0	560001	NODAWAYCO	161.0	1	153	146.3	146.6	3.8%	S1280 to Humboldt	XS300064>301077>\$1
635034	CLRNDA 5	161.0	560001	NODAWAYCO	161.0	1	153	146.3	146.6	3.8%	S1280 to Humboldt	XS300045>549984>\$1
635034	CLRNDA 5	161.0	560001	NODAWAYCO	161.0	1	153	146.4	146.6	3.8%	S1280 to Humboldt	XS300092>301063>\$1
635034	CLRNDA 5	161.0	560001	NODAWAYCO	161.0	1	153	146.4	146.6	3.8%	S1280 to Humboldt	XS300074>301138>\$1
635034	CLRNDA 5	161.0	560001	NODAWAYCO	161.0	1	153	146.3	146.6	3.8%	S1280 to Humboldt	XS300047>300112>\$1
635034	CLRNDA 5	161.0	560001	NODAWAYCO	161.0	1	153	146.4	146.6	3.8%	S1280 to Humboldt	XS300041>300078>\$1
635034	CLRNDA 5	161.0	560001	NODAWAYCO	161.0	1	153	146.4	146.6	3.8%	S1280 to Humboldt	MC930-18-19

635034	CLRND 5	161.0	560001	NODAWAYCO	161.0	1	153	146.4	146.6	3.8%	S1280 to Humboldt	XS300040>300077>300175\$1
635034	CLRND 5	161.0	560001	NODAWAYCO	161.0	1	153	146.4	146.6	3.8%	S1280 to Humboldt	XS300092>301070>\$1
635034	CLRND 5	161.0	560001	NODAWAYCO	161.0	1	153	146.3	146.6	3.8%	S1280 to Humboldt	MC995-38-94
635034	CLRND 5	161.0	560001	NODAWAYCO	161.0	1	153	146.4	146.6	3.8%	S1280 to Humboldt	XS300095>301057>\$1
635034	CLRND 5	161.0	560001	NODAWAYCO	161.0	1	153	146.4	146.6	3.8%	S1280 to Humboldt	XS300041>300078>\$2
635034	CLRND 5	161.0	560001	NODAWAYCO	161.0	1	153	146.4	146.6	3.8%	S1280 to Humboldt	XS300082>300105>\$1
635034	CLRND 5	161.0	560001	NODAWAYCO	161.0	1	153	146.3	146.6	3.8%	S1280 to Humboldt	XS300057>300555>\$1
635034	CLRND 5	161.0	560001	NODAWAYCO	161.0	1	153	146.3	146.6	3.8%	S1280 to Humboldt	XS300078>300092>\$1
635034	CLRND 5	161.0	560001	NODAWAYCO	161.0	1	153	146.3	146.6	3.8%	S1280 to Humboldt	S964-S993
635034	CLRND 5	161.0	560001	NODAWAYCO	161.0	1	153	146.3	146.6	3.8%	S1280 to Humboldt	XS300088>301077>\$1
635034	CLRND 5	161.0	560001	NODAWAYCO	161.0	1	153	146.4	146.6	3.8%	S1280 to Humboldt	XS300083>300103>\$1
635034	CLRND 5	161.0	560001	NODAWAYCO	161.0	1	153	146.4	146.6	3.8%	S1280 to Humboldt	XS300080>301015>\$1
635034	CLRND 5	161.0	560001	NODAWAYCO	161.0	1	153	146.3	146.6	3.8%	S1280 to Humboldt	XS300080>301076>\$1
635034	CLRND 5	161.0	560001	NODAWAYCO	161.0	1	153	146.4	146.6	3.8%	S1280 to Humboldt	XS300081>300095>\$1
635034	CLRND 5	161.0	560001	NODAWAYCO	161.0	1	153	146.4	146.6	3.8%	S1280 to Humboldt	XS300078>300080>\$1
635034	CLRND 5	161.0	560001	NODAWAYCO	161.0	1	153	146.4	146.6	3.8%	S1280 to Humboldt	XS300087>300226>\$1
635034	CLRND 5	161.0	560001	NODAWAYCO	161.0	1	153	146.3	146.6	3.8%	S1280 to Humboldt	XS300084>300115>\$1
635034	CLRND 5	161.0	560001	NODAWAYCO	161.0	1	153	146.4	146.6	3.8%	S1280 to Humboldt	XS300088>300109>\$1
635034	CLRND 5	161.0	560001	NODAWAYCO	161.0	1	153	146.4	146.6	3.8%	S1280 to Humboldt	XS300076>301347>\$1
635034	CLRND 5	161.0	560001	NODAWAYCO	161.0	1	153	146.3	146.6	3.8%	S1280 to Humboldt	XS300054>300168>\$1
635034	CLRND 5	161.0	560001	NODAWAYCO	161.0	1	153	146.4	146.6	3.8%	S1280 to Humboldt	S976-FRE-D-E
635034	CLRND 5	161.0	560001	NODAWAYCO	161.0	1	153	146.4	146.6	3.8%	S1280 to Humboldt	XS300102>301159>\$1
635034	CLRND 5	161.0	560001	NODAWAYCO	161.0	1	153	146.4	146.6	3.8%	S1280 to Humboldt	XS300069>300741>\$1
635034	CLRND 5	161.0	560001	NODAWAYCO	161.0	1	153	146.4	146.6	3.8%	S1280 to Humboldt	XS300038>300075>\$1
635034	CLRND 5	161.0	560001	NODAWAYCO	161.0	1	153	146.4	146.6	3.8%	S1280 to Humboldt	XS300590>300606>\$1
635034	CLRND 5	161.0	560001	NODAWAYCO	161.0	1	153	146.4	146.6	3.8%	S1280 to Humboldt	XS300597>345543>\$1
635034	CLRND 5	161.0	560001	NODAWAYCO	161.0	1	153	146.4	146.6	3.8%	S1280 to Humboldt	XS300597>344535>\$1

635034	CLRND 5	161.0	560001	NODAWAYCO	161.0	1	153	146.4	146.6	3.8%	S1280 to Humboldt	XS300597>300602>\$1
635034	CLRND 5	161.0	560001	NODAWAYCO	161.0	1	153	146.4	146.6	3.8%	S1280 to Humboldt	XS532872>533417>532894\$1
635034	CLRND 5	161.0	560001	NODAWAYCO	161.0	1	153	146.4	146.6	3.8%	S1280 to Humboldt	XS300596>300602>\$1
635034	CLRND 5	161.0	560001	NODAWAYCO	161.0	1	153	146.3	146.6	3.8%	S1280 to Humboldt	XS300595>345498>\$1
635034	CLRND 5	161.0	560001	NODAWAYCO	161.0	1	153	146.4	146.6	3.8%	S1280 to Humboldt	XS300599>344880>\$1
635034	CLRND 5	161.0	560001	NODAWAYCO	161.0	1	153	146.4	146.6	3.8%	S1280 to Humboldt	XS300593>344773>\$1
635034	CLRND 5	161.0	560001	NODAWAYCO	161.0	1	153	146.4	146.6	3.8%	S1280 to Humboldt	XS300590>300595>\$1
635034	CLRND 5	161.0	560001	NODAWAYCO	161.0	1	153	146.4	146.6	3.8%	S1280 to Humboldt	XS300740>512650>\$1
635034	CLRND 5	161.0	560001	NODAWAYCO	161.0	1	153	146.4	146.6	3.8%	S1280 to Humboldt	XS300617>344028>\$1
635034	CLRND 5	161.0	560001	NODAWAYCO	161.0	1	153	146.4	146.6	3.8%	S1280 to Humboldt	XS300140>509757>\$1
635034	CLRND 5	161.0	560001	NODAWAYCO	161.0	1	153	146.4	146.6	3.8%	S1280 to Humboldt	XS300142>301144>\$1
635034	CLRND 5	161.0	560001	NODAWAYCO	161.0	1	153	146.4	146.6	3.8%	S1280 to Humboldt	XS300501>343015>\$1
635034	CLRND 5	161.0	560001	NODAWAYCO	161.0	1	153	146.4	146.6	3.8%	S1280 to Humboldt	XS300140>300141>\$1
635034	CLRND 5	161.0	560001	NODAWAYCO	161.0	1	153	146.4	146.6	3.8%	S1280 to Humboldt	XS300138>512694>512817\$1
635034	CLRND 5	161.0	560001	NODAWAYCO	161.0	1	153	146.4	146.6	3.8%	S1280 to Humboldt	XS532873>533381>532896\$1
635034	CLRND 5	161.0	560001	NODAWAYCO	161.0	1	153	146.4	146.6	3.8%	S1280 to Humboldt	XS532873>533381>532897\$1
635034	CLRND 5	161.0	560001	NODAWAYCO	161.0	1	153	146.3	146.6	3.8%	S1280 to Humboldt	XS532853>533250>532882\$1
635034	CLRND 5	161.0	560001	NODAWAYCO	161.0	1	153	146.4	146.6	3.8%	S1280 to Humboldt	XS532855>533252>532884\$1
635034	CLRND 5	161.0	560001	NODAWAYCO	161.0	1	153	146.4	146.6	3.8%	S1280 to Humboldt	XS532853>532855>\$1
635034	CLRND 5	161.0	560001	NODAWAYCO	161.0	1	153	146.4	146.6	3.8%	S1280 to Humboldt	XS532791>532794>\$1
635034	CLRND 5	161.0	560001	NODAWAYCO	161.0	1	153	146.4	146.6	3.8%	S1280 to Humboldt	XS532780>532800>\$1
635034	CLRND 5	161.0	560001	NODAWAYCO	161.0	1	153	146.3	146.6	3.8%	S1280 to Humboldt	XS532794>532800>\$1
635034	CLRND 5	161.0	560001	NODAWAYCO	161.0	1	153	146.4	146.6	3.8%	S1280 to Humboldt	XS301057>301070>\$1
635034	CLRND 5	161.0	560001	NODAWAYCO	161.0	1	153	146.4	146.6	3.8%	S1280 to Humboldt	XS300867>505550>\$1
635034	CLRND 5	161.0	560001	NODAWAYCO	161.0	1	153	146.4	146.6	3.8%	S1280 to Humboldt	XS301063>301076>\$1
635034	CLRND 5	161.0	560001	NODAWAYCO	161.0	1	153	146.3	146.6	3.8%	S1280 to Humboldt	XS300867>505522>\$1
635034	CLRND 5	161.0	560001	NODAWAYCO	161.0	1	153	146.4	146.6	3.8%	S1280 to Humboldt	XS301161>549970>\$1

635034	CLRNDA 5	161.0	560001	NODAWAYCO	161.0	1	153	146.4	146.6	3.8%	S1280 to Humboldt	XS301128>301171>\$1
635034	CLRNDA 5	161.0	560001	NODAWAYCO	161.0	1	153	146.4	146.6	3.8%	S1280 to Humboldt	XS300122>300917>\$1
635034	CLRNDA 5	161.0	560001	NODAWAYCO	161.0	1	153	146.4	146.6	3.8%	S1280 to Humboldt	XS300122>300858>\$1
635034	CLRNDA 5	161.0	560001	NODAWAYCO	161.0	1	153	146.4	146.6	3.8%	S1280 to Humboldt	XS300112>301015>\$1
635034	CLRNDA 5	161.0	560001	NODAWAYCO	161.0	1	153	146.4	146.6	3.8%	S1280 to Humboldt	XS300134>300593>\$1
635034	CLRNDA 5	161.0	560001	NODAWAYCO	161.0	1	153	146.4	146.6	3.8%	S1280 to Humboldt	XS300109>301071>\$1
635034	CLRNDA 5	161.0	560001	NODAWAYCO	161.0	1	153	146.4	146.6	3.8%	S1280 to Humboldt	XS300122>300123>\$1
635034	CLRNDA 5	161.0	560001	NODAWAYCO	161.0	1	153	146.4	146.6	3.8%	S1280 to Humboldt	XS300123>301123>\$2
635034	CLRNDA 5	161.0	560001	NODAWAYCO	161.0	1	153	146.4	146.6	3.8%	S1280 to Humboldt	XS300120>300172>\$2
635034	CLRNDA 5	161.0	560001	NODAWAYCO	161.0	1	153	146.4	146.6	3.8%	S1280 to Humboldt	XS300126>345221>\$1
635034	CLRNDA 5	161.0	560001	NODAWAYCO	161.0	1	153	146.4	146.6	3.8%	S1280 to Humboldt	XS300123>301123>\$1
635034	CLRNDA 5	161.0	560001	NODAWAYCO	161.0	1	153	146.4	146.6	3.8%	S1280 to Humboldt	XS300119>300142>\$1
635034	CLRNDA 5	161.0	560001	NODAWAYCO	161.0	1	153	146.4	146.6	3.8%	S1280 to Humboldt	XS300118>505498>\$1
635034	CLRNDA 5	161.0	560001	NODAWAYCO	161.0	1	153	146.4	146.6	3.8%	S1280 to Humboldt	XS300118>300793>\$1
635034	CLRNDA 5	161.0	560001	NODAWAYCO	161.0	1	153	146.4	146.6	3.8%	S1280 to Humboldt	XS300134>300599>\$1
635034	CLRNDA 5	161.0	560001	NODAWAYCO	161.0	1	153	146.4	146.6	3.8%	S1280 to Humboldt	XS300113>300349>\$2
635034	CLRNDA 5	161.0	560001	NODAWAYCO	161.0	1	153	146.4	146.6	3.8%	S1280 to Humboldt	XS300135>300856>\$1
635034	CLRNDA 5	161.0	560001	NODAWAYCO	161.0	1	153	146.4	146.6	3.8%	S1280 to Humboldt	XS532934>532937>\$1
635034	CLRNDA 5	161.0	560001	NODAWAYCO	161.0	1	153	146.4	146.6	3.8%	S1280 to Humboldt	XS300120>300172>\$1
635034	CLRNDA 5	161.0	560001	NODAWAYCO	161.0	1	153	146.4	146.6	3.8%	S1280 to Humboldt	XS300113>300349>\$1
635034	CLRNDA 5	161.0	560001	NODAWAYCO	161.0	1	153	146.4	146.6	3.8%	S1280 to Humboldt	XS533262>533267>\$1
635034	CLRNDA 5	161.0	560001	NODAWAYCO	161.0	1	153	146.4	146.6	3.8%	S1280 to Humboldt	XS533153>533456>533443\$1
635034	CLRNDA 5	161.0	560001	NODAWAYCO	161.0	1	153	146.4	146.6	3.8%	S1280 to Humboldt	XS533035>533786>533103\$1
635034	CLRNDA 5	161.0	560001	NODAWAYCO	161.0	1	153	146.4	146.6	3.8%	S1280 to Humboldt	XS533253>533271>\$1
635034	CLRNDA 5	161.0	560001	NODAWAYCO	161.0	1	153	146.4	146.6	3.8%	S1280 to Humboldt	XS533253>533270>\$1
635034	CLRNDA 5	161.0	560001	NODAWAYCO	161.0	1	153	146.3	146.6	3.8%	S1280 to Humboldt	XS533252>533261>\$1
635034	CLRNDA 5	161.0	560001	NODAWAYCO	161.0	1	153	146.4	146.6	3.8%	S1280 to Humboldt	XS533165>533199>\$1

635034	CLRNDA 5 161.0	560001	NODAWAYCO 161.0	1	153	146.4	146.6	3.8%	S1280 to Humboldt	XS533332>640426>\$1
635034	CLRNDA 5 161.0	560001	NODAWAYCO 161.0	1	153	146.4	146.6	3.8%	S1280 to Humboldt	XS533163>533199>\$1
635034	CLRNDA 5 161.0	560001	NODAWAYCO 161.0	1	153	146.4	146.6	3.8%	S1280 to Humboldt	XS533030>533068>\$1
635034	CLRNDA 5 161.0	560001	NODAWAYCO 161.0	1	153	146.4	146.6	3.8%	S1280 to Humboldt	XS532991>533062>\$1
635034	CLRNDA 5 161.0	560001	NODAWAYCO 161.0	1	153	146.4	146.6	3.8%	S1280 to Humboldt	XS532996>533646>533084\$1
635034	CLRNDA 5 161.0	560001	NODAWAYCO 161.0	1	153	146.4	146.6	3.8%	S1280 to Humboldt	XS533040>533065>\$1
635034	CLRNDA 5 161.0	560001	NODAWAYCO 161.0	1	153	146.4	146.6	3.8%	S1280 to Humboldt	XS532996>533001>\$1
635034	CLRNDA 5 161.0	560001	NODAWAYCO 161.0	1	153	146.4	146.6	3.8%	S1280 to Humboldt	XS533304>533306>\$1
635034	CLRNDA 5 161.0	560001	NODAWAYCO 161.0	1	153	146.4	146.6	3.8%	S1280 to Humboldt	XS533062>533068>\$1
635034	CLRNDA 5 161.0	560001	NODAWAYCO 161.0	1	153	146.4	146.6	3.8%	S1280 to Humboldt	XS533341>533345>\$1
635034	CLRNDA 5 161.0	560001	NODAWAYCO 161.0	1	153	146.4	146.6	3.8%	S1280 to Humboldt	XS533039>533793>533105\$1
635034	CLRNDA 5 161.0	560001	NODAWAYCO 161.0	1	153	146.4	146.6	3.8%	S1280 to Humboldt	XS533238>533282>\$1
635034	CLRNDA 5 161.0	560001	NODAWAYCO 161.0	1	153	146.4	146.6	3.8%	S1280 to Humboldt	XS533235>533240>\$1
635034	CLRNDA 5 161.0	560001	NODAWAYCO 161.0	1	153	146.4	146.6	3.8%	S1280 to Humboldt	XS533235>533283>\$1
635034	CLRNDA 5 161.0	560001	NODAWAYCO 161.0	1	153	146.4	146.6	3.8%	S1280 to Humboldt	XS533005>533021>\$1
635034	CLRNDA 5 161.0	560001	NODAWAYCO 161.0	1	153	146.4	146.6	3.8%	S1280 to Humboldt	XS533240>533277>\$1
635034	CLRNDA 5 161.0	560001	NODAWAYCO 161.0	1	153	146.4	146.6	3.8%	S1280 to Humboldt	XS533182>533187>\$1
635034	CLRNDA 5 161.0	560001	NODAWAYCO 161.0	1	153	146.4	146.6	3.8%	S1280 to Humboldt	XS533219>533252>\$1
635034	CLRNDA 5 161.0	560001	NODAWAYCO 161.0	1	153	146.4	146.6	3.8%	S1280 to Humboldt	XS533002>533688>533089\$1
635034	CLRNDA 5 161.0	560001	NODAWAYCO 161.0	1	153	146.4	146.6	3.8%	S1280 to Humboldt	XS533015>533065>\$1
635034	CLRNDA 5 161.0	560001	NODAWAYCO 161.0	1	153	146.4	146.6	3.8%	S1280 to Humboldt	XS659134>659210>\$1
635034	CLRNDA 5 161.0	560001	NODAWAYCO 161.0	1	153	146.4	146.6	3.8%	S1280 to Humboldt	XS659154>659188>\$1
635034	CLRNDA 5 161.0	560001	NODAWAYCO 161.0	1	153	146.4	146.6	3.8%	S1280 to Humboldt	XS652522>652438>\$1
635034	CLRNDA 5 161.0	560001	NODAWAYCO 161.0	1	153	146.4	146.6	3.8%	S1280 to Humboldt	XS659133>659209>\$1
635034	CLRNDA 5 161.0	560001	NODAWAYCO 161.0	1	153	146.4	146.6	3.8%	S1280 to Humboldt	XS659133>659131>\$1
635034	CLRNDA 5 161.0	560001	NODAWAYCO 161.0	1	153	146.4	146.6	3.8%	S1280 to Humboldt	XS652534>652432>\$1
635034	CLRNDA 5 161.0	560001	NODAWAYCO 161.0	1	153	146.4	146.6	3.8%	S1280 to Humboldt	XS659192>659197>\$1

635034	CLRND 5	161.0	560001	NODAWAYCO	161.0	1	153	146.3	146.6	3.8%	S1280 to Humboldt	XS652535>652291>\$1
635034	CLRND 5	161.0	560001	NODAWAYCO	161.0	1	153	146.4	146.6	3.8%	S1280 to Humboldt	XS652509>652510>\$2
635034	CLRND 5	161.0	560001	NODAWAYCO	161.0	1	153	146.4	146.6	3.8%	S1280 to Humboldt	XS659130>659132>\$1
635034	CLRND 5	161.0	560001	NODAWAYCO	161.0	1	153	146.4	146.6	3.8%	S1280 to Humboldt	XS652509>652510>\$1
635034	CLRND 5	161.0	560001	NODAWAYCO	161.0	1	153	146.4	146.6	3.8%	S1280 to Humboldt	XS652508>652551>\$1
635034	CLRND 5	161.0	560001	NODAWAYCO	161.0	1	153	146.3	146.6	3.8%	S1280 to Humboldt	XS659132>659246>\$1
635034	CLRND 5	161.0	560001	NODAWAYCO	161.0	1	153	146.4	146.6	3.8%	S1280 to Humboldt	XS652550>652582>\$1
635034	CLRND 5	161.0	560001	NODAWAYCO	161.0	1	153	146.4	146.6	3.8%	S1280 to Humboldt	XS652521>652527>\$1
635034	CLRND 5	161.0	560001	NODAWAYCO	161.0	1	153	146.4	146.6	3.8%	S1280 to Humboldt	XS659130>659188>\$1
635034	CLRND 5	161.0	560001	NODAWAYCO	161.0	1	153	146.4	146.6	3.8%	S1280 to Humboldt	XS652519>652521>\$1
635034	CLRND 5	161.0	560001	NODAWAYCO	161.0	1	153	146.4	146.6	3.8%	S1280 to Humboldt	XS659130>659132>\$2
635034	CLRND 5	161.0	560001	NODAWAYCO	161.0	1	153	146.4	146.6	3.8%	S1280 to Humboldt	XS652512>659203>\$1
635034	CLRND 5	161.0	560001	NODAWAYCO	161.0	1	153	146.4	146.6	3.8%	S1280 to Humboldt	XS652465>652447>\$1
635034	CLRND 5	161.0	560001	NODAWAYCO	161.0	1	153	146.4	146.6	3.8%	S1280 to Humboldt	XS652465>652431>\$1
635034	CLRND 5	161.0	560001	NODAWAYCO	161.0	1	153	146.4	146.6	3.8%	S1280 to Humboldt	XS659210>659209>\$1
635034	CLRND 5	161.0	560001	NODAWAYCO	161.0	1	153	146.4	146.6	3.8%	S1280 to Humboldt	XS652527>661038>\$1
635034	CLRND 5	161.0	560001	NODAWAYCO	161.0	1	153	146.4	146.6	3.8%	S1280 to Humboldt	XS652398>652526>\$1
635034	CLRND 5	161.0	560001	NODAWAYCO	161.0	1	153	146.4	146.6	3.8%	S1280 to Humboldt	XS652530>652582>\$1
635034	CLRND 5	161.0	560001	NODAWAYCO	161.0	1	153	146.4	146.6	3.8%	S1280 to Humboldt	XS652482>652495>\$1
635034	CLRND 5	161.0	560001	NODAWAYCO	161.0	1	153	146.4	146.6	3.8%	S1280 to Humboldt	LES7101
635034	CLRND 5	161.0	560001	NODAWAYCO	161.0	1	153	146.3	146.6	3.8%	S1280 to Humboldt	CB1231-09&35
635034	CLRND 5	161.0	560001	NODAWAYCO	161.0	1	153	146.4	146.6	3.8%	S1280 to Humboldt	CB1235-36&53
635034	CLRND 5	161.0	560001	NODAWAYCO	161.0	1	153	146.4	146.6	3.8%	S1280 to Humboldt	CB917-BUS
635034	CLRND 5	161.0	560001	NODAWAYCO	161.0	1	153	146.4	146.6	3.8%	S1280 to Humboldt	CB1235-31&36
635034	CLRND 5	161.0	560001	NODAWAYCO	161.0	1	153	146.4	146.6	3.8%	S1280 to Humboldt	CB923-12-PXM
635034	CLRND 5	161.0	560001	NODAWAYCO	161.0	1	153	146.4	146.6	3.8%	S1280 to Humboldt	CB971-BUS990
635034	CLRND 5	161.0	560001	NODAWAYCO	161.0	1	153	146.4	146.6	3.8%	S1280 to Humboldt	CB1210-22&T7

635034	CLRND 5	161.0	560001	NODAWAYCO	161.0	1	153	146.3	146.6	3.8%	S1280 to Humboldt	CB1206-01&T2
635034	CLRND 5	161.0	560001	NODAWAYCO	161.0	1	153	146.4	146.6	3.8%	S1280 to Humboldt	LES7103
635034	CLRND 5	161.0	560001	NODAWAYCO	161.0	1	153	146.4	146.6	3.8%	S1280 to Humboldt	CB1209-50&31
635034	CLRND 5	161.0	560001	NODAWAYCO	161.0	1	153	146.4	146.6	3.8%	S1280 to Humboldt	D-CIRCUIT #4
635034	CLRND 5	161.0	560001	NODAWAYCO	161.0	1	153	146.4	146.6	3.8%	S1280 to Humboldt	CB968TEC7469
635034	CLRND 5	161.0	560001	NODAWAYCO	161.0	1	153	146.3	146.6	3.8%	S1280 to Humboldt	CB1305-BUS
635034	CLRND 5	161.0	560001	NODAWAYCO	161.0	1	153	146.4	146.6	3.8%	S1280 to Humboldt	LES1402A
635034	CLRND 5	161.0	560001	NODAWAYCO	161.0	1	153	146.4	146.6	3.8%	S1280 to Humboldt	LES1403
635034	CLRND 5	161.0	560001	NODAWAYCO	161.0	1	153	146.3	146.6	3.8%	S1280 to Humboldt	CB1250-11&T1
635034	CLRND 5	161.0	560001	NODAWAYCO	161.0	1	153	146.3	146.6	3.8%	S1280 to Humboldt	CB1250-09&T1
635034	CLRND 5	161.0	560001	NODAWAYCO	161.0	1	153	146.4	146.6	3.8%	S1280 to Humboldt	LES7002
635034	CLRND 5	161.0	560001	NODAWAYCO	161.0	1	153	146.4	146.6	3.8%	S1280 to Humboldt	CB909-BUS
635034	CLRND 5	161.0	560001	NODAWAYCO	161.0	1	153	146.4	146.6	3.8%	S1280 to Humboldt	CB910-BUS
635034	CLRND 5	161.0	560001	NODAWAYCO	161.0	1	153	146.4	146.6	3.8%	S1280 to Humboldt	CB910BUS1210
635034	CLRND 5	161.0	560001	NODAWAYCO	161.0	1	153	146.4	146.6	3.8%	S1280 to Humboldt	CBFREM-D-C-B
635034	CLRND 5	161.0	560001	NODAWAYCO	161.0	1	153	146.4	146.6	3.8%	S1280 to Humboldt	BKR-GRI-1396
635034	CLRND 5	161.0	560001	NODAWAYCO	161.0	1	153	146.4	146.6	3.8%	S1280 to Humboldt	LN-1181
635034	CLRND 5	161.0	560001	NODAWAYCO	161.0	1	153	146.3	146.6	3.8%	S1280 to Humboldt	CB995-BUS
635034	CLRND 5	161.0	560001	NODAWAYCO	161.0	1	153	146.3	146.6	3.8%	S1280 to Humboldt	MC1209-1231
635034	CLRND 5	161.0	560001	NODAWAYCO	161.0	1	153	146.3	146.6	3.8%	S1280 to Humboldt	LN-FRIEND
635034	CLRND 5	161.0	560001	NODAWAYCO	161.0	1	153	146.3	146.6	3.8%	S1280 to Humboldt	XS542993>542994>\$1
635034	CLRND 5	161.0	560001	NODAWAYCO	161.0	1	153	146.4	146.6	3.8%	S1280 to Humboldt	XS543031>543049>\$1
635034	CLRND 5	161.0	560001	NODAWAYCO	161.0	1	153	146.4	146.6	3.8%	S1280 to Humboldt	XS542991>546651>\$1
635034	CLRND 5	161.0	560001	NODAWAYCO	161.0	1	153	146.4	146.6	3.8%	S1280 to Humboldt	XS541222>541224>\$1
635034	CLRND 5	161.0	560001	NODAWAYCO	161.0	1	153	146.4	146.6	3.8%	S1280 to Humboldt	XS542995>541245>\$1
635034	CLRND 5	161.0	560001	NODAWAYCO	161.0	1	153	146.4	146.6	3.8%	S1280 to Humboldt	XS542995>541207>\$1
635034	CLRND 5	161.0	560001	NODAWAYCO	161.0	1	153	146.4	146.6	3.8%	S1280 to Humboldt	XS542966>543049>\$1

635034	CLRND 5	161.0	560001	NODAWAYCO	161.0	1	153	146.4	146.6	3.8%	S1280 to Humboldt	XS542993>543001>\$1
635034	CLRND 5	161.0	560001	NODAWAYCO	161.0	1	153	146.4	146.6	3.8%	S1280 to Humboldt	XS533416>533429>\$1
635034	CLRND 5	161.0	560001	NODAWAYCO	161.0	1	153	146.4	146.6	3.8%	S1280 to Humboldt	XS542989>542991>\$1
635034	CLRND 5	161.0	560001	NODAWAYCO	161.0	1	153	146.4	146.6	3.8%	S1280 to Humboldt	XS541237>541238>\$1
635034	CLRND 5	161.0	560001	NODAWAYCO	161.0	1	153	146.3	146.6	3.8%	S1280 to Humboldt	XS542969>543053>\$1
635034	CLRND 5	161.0	560001	NODAWAYCO	161.0	1	153	146.4	146.6	3.8%	S1280 to Humboldt	XS541225>541243>\$1
635034	CLRND 5	161.0	560001	NODAWAYCO	161.0	1	153	146.3	146.6	3.8%	S1280 to Humboldt	XS542985>543021>\$1
635034	CLRND 5	161.0	560001	NODAWAYCO	161.0	1	153	146.4	146.6	3.8%	S1280 to Humboldt	XS541209>541271>\$1
635034	CLRND 5	161.0	560001	NODAWAYCO	161.0	1	153	146.3	146.6	3.8%	S1280 to Humboldt	XS543017>546669>\$1
635034	CLRND 5	161.0	560001	NODAWAYCO	161.0	1	153	146.4	146.6	3.8%	S1280 to Humboldt	XS542999>543008>\$1
635034	CLRND 5	161.0	560001	NODAWAYCO	161.0	1	153	146.4	146.6	3.8%	S1280 to Humboldt	XS542999>541317>\$1
635034	CLRND 5	161.0	560001	NODAWAYCO	161.0	1	153	146.4	146.6	3.8%	S1280 to Humboldt	XS533419>533440>\$1
635034	CLRND 5	161.0	560001	NODAWAYCO	161.0	1	153	146.4	146.6	3.8%	S1280 to Humboldt	XS541340>541290>\$1
635034	CLRND 5	161.0	560001	NODAWAYCO	161.0	1	153	146.4	146.6	3.8%	S1280 to Humboldt	XS543000>548820>\$1
635034	CLRND 5	161.0	560001	NODAWAYCO	161.0	1	153	146.4	146.6	3.8%	S1280 to Humboldt	XS543002>543053>\$1
635034	CLRND 5	161.0	560001	NODAWAYCO	161.0	1	153	146.4	146.6	3.8%	S1280 to Humboldt	XS541224>541249>\$1
635034	CLRND 5	161.0	560001	NODAWAYCO	161.0	1	153	146.4	146.6	3.8%	S1280 to Humboldt	XS541235>543091>\$1
635034	CLRND 5	161.0	560001	NODAWAYCO	161.0	1	153	146.4	146.6	3.8%	S1280 to Humboldt	XS533417>533427>\$1
635034	CLRND 5	161.0	560001	NODAWAYCO	161.0	1	153	146.3	146.6	3.8%	S1280 to Humboldt	XS542995>541317>\$1
635034	CLRND 5	161.0	560001	NODAWAYCO	161.0	1	153	146.4	146.6	3.8%	S1280 to Humboldt	XS541200>541201>\$1
635034	CLRND 5	161.0	560001	NODAWAYCO	161.0	1	153	146.4	146.6	3.8%	S1280 to Humboldt	XS543036>543046>\$1
635034	CLRND 5	161.0	560001	NODAWAYCO	161.0	1	153	146.4	146.6	3.8%	S1280 to Humboldt	XS542972>542973>543645\$22
635034	CLRND 5	161.0	560001	NODAWAYCO	161.0	1	153	146.4	146.6	3.8%	S1280 to Humboldt	XS541243>541249>\$1
635034	CLRND 5	161.0	560001	NODAWAYCO	161.0	1	153	146.4	146.6	3.8%	S1280 to Humboldt	XS543037>543043>\$1
635034	CLRND 5	161.0	560001	NODAWAYCO	161.0	1	153	146.4	146.6	3.8%	S1280 to Humboldt	XS543037>543044>\$1
635034	CLRND 5	161.0	560001	NODAWAYCO	161.0	1	153	146.4	146.6	3.8%	S1280 to Humboldt	XS541225>541313>\$1
635034	CLRND 5	161.0	560001	NODAWAYCO	161.0	1	153	146.3	146.6	3.8%	S1280 to Humboldt	XS542977>542978>543642\$22

635034	CLRND 5	161.0	560001	NODAWAYCO	161.0	1	153	146.4	146.6	3.8%	S1280 to Humboldt	XS541248>543095>\$1
635034	CLRND 5	161.0	560001	NODAWAYCO	161.0	1	153	146.4	146.6	3.8%	S1280 to Humboldt	XS541210>541382>\$1
635034	CLRND 5	161.0	560001	NODAWAYCO	161.0	1	153	146.4	146.6	3.8%	S1280 to Humboldt	XS543045>543051>\$1
635034	CLRND 5	161.0	560001	NODAWAYCO	161.0	1	153	146.4	146.6	3.8%	S1280 to Humboldt	XS542978>543038>\$1
635034	CLRND 5	161.0	560001	NODAWAYCO	161.0	1	153	146.4	146.6	3.8%	S1280 to Humboldt	XS541242>300071>\$1
635034	CLRND 5	161.0	560001	NODAWAYCO	161.0	1	153	146.4	146.6	3.8%	S1280 to Humboldt	XS542977>542978>543643\$33
635034	CLRND 5	161.0	560001	NODAWAYCO	161.0	1	153	146.4	146.6	3.8%	S1280 to Humboldt	XS542973>548814>\$1
635034	CLRND 5	161.0	560001	NODAWAYCO	161.0	1	153	146.4	146.6	3.8%	S1280 to Humboldt	XS541239>541295>\$1
635034	CLRND 5	161.0	560001	NODAWAYCO	161.0	1	153	146.4	146.6	3.8%	S1280 to Humboldt	XS542973>543020>\$1
635034	CLRND 5	161.0	560001	NODAWAYCO	161.0	1	153	146.4	146.6	3.8%	S1280 to Humboldt	XS542972>542973>543644\$20
635034	CLRND 5	161.0	560001	NODAWAYCO	161.0	1	153	146.4	146.6	3.8%	S1280 to Humboldt	XS543036>543043>\$1
635034	CLRND 5	161.0	560001	NODAWAYCO	161.0	1	153	146.3	146.6	3.8%	S1280 to Humboldt	XS631033>631067>\$1
635034	CLRND 5	161.0	560001	NODAWAYCO	161.0	1	153	146.4	146.6	3.8%	S1280 to Humboldt	XS631086>636210>\$1
635034	CLRND 5	161.0	560001	NODAWAYCO	161.0	1	153	146.3	146.6	3.8%	S1280 to Humboldt	XS631051>631101>\$1
635034	CLRND 5	161.0	560001	NODAWAYCO	161.0	1	153	146.4	146.6	3.8%	S1280 to Humboldt	XS631001>631012>\$1
635034	CLRND 5	161.0	560001	NODAWAYCO	161.0	1	153	146.3	146.6	3.8%	S1280 to Humboldt	XS631002>631005>\$1
635034	CLRND 5	161.0	560001	NODAWAYCO	161.0	1	153	146.3	146.6	3.8%	S1280 to Humboldt	XS631087>629103>\$1
635034	CLRND 5	161.0	560001	NODAWAYCO	161.0	1	153	146.3	146.6	3.8%	S1280 to Humboldt	XS631005>631175>\$1
635034	CLRND 5	161.0	560001	NODAWAYCO	161.0	1	153	146.4	146.6	3.8%	S1280 to Humboldt	XS631044>631174>\$1
635034	CLRND 5	161.0	560001	NODAWAYCO	161.0	1	153	146.3	146.6	3.8%	S1280 to Humboldt	XS631033>271543>\$1
635034	CLRND 5	161.0	560001	NODAWAYCO	161.0	1	153	146.4	146.6	3.8%	S1280 to Humboldt	XS631007>631074>\$1
635034	CLRND 5	161.0	560001	NODAWAYCO	161.0	1	153	146.4	146.6	3.8%	S1280 to Humboldt	XS631007>631074>\$2
635034	CLRND 5	161.0	560001	NODAWAYCO	161.0	1	153	146.3	146.6	3.8%	S1280 to Humboldt	XS631073>631092>\$1
635034	CLRND 5	161.0	560001	NODAWAYCO	161.0	1	153	146.4	146.6	3.8%	S1280 to Humboldt	XS631042>658066>\$2
635034	CLRND 5	161.0	560001	NODAWAYCO	161.0	1	153	146.4	146.6	3.8%	S1280 to Humboldt	XS631041>658066>\$2
635034	CLRND 5	161.0	560001	NODAWAYCO	161.0	1	153	146.4	146.6	3.8%	S1280 to Humboldt	XS631079>630007>\$1
635034	CLRND 5	161.0	560001	NODAWAYCO	161.0	1	153	146.3	146.6	3.8%	S1280 to Humboldt	XS560332>640076>\$1

635034	CLRNDA 5 161.0	560001	NODAWAYCO 161.0	1	153	146.3	146.6	3.8%	S1280 to Humboldt	XS631084>631108>\$1
635034	CLRNDA 5 161.0	560001	NODAWAYCO 161.0	1	153	146.3	146.6	3.8%	S1280 to Humboldt	XS631047>631048>\$1
635034	CLRNDA 5 161.0	560001	NODAWAYCO 161.0	1	153	146.4	146.6	3.8%	S1280 to Humboldt	XS631020>631092>\$1
635034	CLRNDA 5 161.0	560001	NODAWAYCO 161.0	1	153	146.3	146.6	3.8%	S1280 to Humboldt	XS631023>629093>\$1
635034	CLRNDA 5 161.0	560001	NODAWAYCO 161.0	1	153	146.3	146.6	3.8%	S1280 to Humboldt	XS543064>300105>\$1
635034	CLRNDA 5 161.0	560001	NODAWAYCO 161.0	1	153	146.4	146.6	3.8%	S1280 to Humboldt	XS631064>631065>\$1
635034	CLRNDA 5 161.0	560001	NODAWAYCO 161.0	1	153	146.4	146.6	3.8%	S1280 to Humboldt	XS631017>631022>\$1
635034	CLRNDA 5 161.0	560001	NODAWAYCO 161.0	1	153	146.4	146.6	3.8%	S1280 to Humboldt	XS631064>631067>\$1
635034	CLRNDA 5 161.0	560001	NODAWAYCO 161.0	1	153	146.4	146.6	3.8%	S1280 to Humboldt	XS631017>631020>\$1
635034	CLRNDA 5 161.0	560001	NODAWAYCO 161.0	1	153	146.4	146.6	3.8%	S1280 to Humboldt	XS543059>543063>\$1
635034	CLRNDA 5 161.0	560001	NODAWAYCO 161.0	1	153	146.3	146.6	3.8%	S1280 to Humboldt	XS543059>543064>\$1
635034	CLRNDA 5 161.0	560001	NODAWAYCO 161.0	1	153	146.4	146.6	3.8%	S1280 to Humboldt	XS631059>681520>\$1
635034	CLRNDA 5 161.0	560001	NODAWAYCO 161.0	1	153	146.4	146.6	3.8%	S1280 to Humboldt	XS631060>681519>\$1
635034	CLRNDA 5 161.0	560001	NODAWAYCO 161.0	1	153	146.3	146.6	3.8%	S1280 to Humboldt	XS631045>631127>\$1
635034	CLRNDA 5 161.0	560001	NODAWAYCO 161.0	1	153	146.4	146.6	3.8%	S975 (Humboldt) T4 161-69	XS635610>635654>\$1
635034	CLRNDA 5 161.0	560001	NODAWAYCO 161.0	1	153	146.4	146.6	3.8%	S975 (Humboldt) T4 161-69	XS640300>640301>\$1
635034	CLRNDA 5 161.0	560001	NODAWAYCO 161.0	1	153	146.4	146.6	3.8%	S975 (Humboldt) T4 161-69	XS300042>300088>\$1
635034	CLRNDA 5 161.0	560001	NODAWAYCO 161.0	1	153	146.4	146.6	3.8%	S975 (Humboldt) T4 161-69	LN-1160
635034	CLRNDA 5 161.0	560001	NODAWAYCO 161.0	1	153	146.4	146.6	3.8%	S975 (Humboldt) T4 161-69	S962-KM-S971
635034	CLRNDA 5 161.0	560001	NODAWAYCO 161.0	1	153	146.4	146.6	3.8%	S975 (Humboldt) T4 161-69	XS650169>646214>\$1
635034	CLRNDA 5 161.0	560001	NODAWAYCO 161.0	1	153	146.4	146.6	3.8%	S975 (Humboldt) T4 161-69	XS650169>650269>650369\$1
635034	CLRNDA 5 161.0	560001	NODAWAYCO 161.0	1	153	146.4	146.6	3.8%	S975 (Humboldt) T4 161-69	XS650208>650408>650608\$1
635034	CLRNDA 5 161.0	560001	NODAWAYCO 161.0	1	153	146.4	146.6	3.8%	S975 (Humboldt) T4 161-69	XS650208>650508>650708\$1
635034	CLRNDA 5 161.0	560001	NODAWAYCO 161.0	1	153	146.4	146.6	3.8%	S975 (Humboldt) T4 161-69	XS650212>650312>650512\$1
635034	CLRNDA 5 161.0	560001	NODAWAYCO 161.0	1	153	146.4	146.6	3.8%	S975 (Humboldt) T4 161-69	XS631123>631154>\$1

635034	CLRND 5 161.0	560001	NODAWAYCO 161.0	1	153	146.4	146.6	3.8%	S975 (Humboldt) T4 161-69	XS631081>631083>\$1
635034	CLRND 5 161.0	560001	NODAWAYCO 161.0	1	153	146.4	146.6	3.8%	S975 (Humboldt) T4 161-69	XS631002>631010>\$1
635034	CLRND 5 161.0	560001	NODAWAYCO 161.0	1	153	146.4	146.6	3.8%	S975 (Humboldt) T4 161-69	LES3005
635034	CLRND 5 161.0	560001	NODAWAYCO 161.0	1	153	146.4	146.6	3.8%	S975 (Humboldt) T4 161-69	CB906N-BT61
635034	CLRND 5 161.0	560001	NODAWAYCO 161.0	1	153	146.4	146.6	3.8%	S975 (Humboldt) T4 161-69	D-CIRCUIT #6
635034	CLRND 5 161.0	560001	NODAWAYCO 161.0	1	153	146.4	146.6	3.8%	S975 (Humboldt) T4 161-69	CB1250-09&97
635034	CLRND 5 161.0	560001	NODAWAYCO 161.0	1	153	146.4	146.6	3.8%	S975 (Humboldt) T4 161-69	LES0008
635034	CLRND 5 161.0	560001	NODAWAYCO 161.0	1	153	146.4	146.6	3.8%	S975 (Humboldt) T4 161-69	LES1405
635034	CLRND 5 161.0	560001	NODAWAYCO 161.0	1	153	146.4	146.6	3.8%	S975 (Humboldt) T4 161-69	LES0018
635034	CLRND 5 161.0	560001	NODAWAYCO 161.0	1	153	146.4	146.6	3.8%	S975 (Humboldt) T4 161-69	CB3454-55&T1
635034	CLRND 5 161.0	560001	NODAWAYCO 161.0	1	153	146.4	146.6	3.8%	S975 (Humboldt) T4 161-69	LES1503A
635034	CLRND 5 161.0	560001	NODAWAYCO 161.0	1	153	146.3	146.6	3.8%	S1280 to Humboldt	XS631109>347840>\$1
635034	CLRND 5 161.0	560001	NODAWAYCO 161.0	1	153	146.3	146.6	3.8%	S1280 to Humboldt	XS640363>640364>\$1
635034	CLRND 5 161.0	560001	NODAWAYCO 161.0	1	153	146.3	146.6	3.8%	S1280 to Humboldt	XS640263>640264>\$1
635034	CLRND 5 161.0	560001	NODAWAYCO 161.0	1	153	146.3	146.6	3.8%	S1280 to Humboldt	XS640222>640223>\$1
635034	CLRND 5 161.0	560001	NODAWAYCO 161.0	1	153	146.3	146.6	3.8%	S1280 to Humboldt	XS647091>647991>\$1
635034	CLRND 5 161.0	560001	NODAWAYCO 161.0	1	153	146.3	146.6	3.8%	S1280 to Humboldt	S991TAP
635034	CLRND 5 161.0	560001	NODAWAYCO 161.0	1	153	146.3	146.6	3.8%	S1280 to Humboldt	MC1235-31-34
635034	CLRND 5 161.0	560001	NODAWAYCO 161.0	1	153	146.3	146.6	3.8%	S1280 to Humboldt	CB6846-BUS
635034	CLRND 5 161.0	560001	NODAWAYCO 161.0	1	153	146.3	146.6	3.8%	S1280 to Humboldt	XS543046>543050>\$1
635034	CLRND 5 161.0	560001	NODAWAYCO 161.0	1	153	146.3	146.6	3.8%	S1280 to Humboldt	XS542978>542979>\$1
635034	CLRND 5 161.0	560001	NODAWAYCO 161.0	1	153	146.3	146.6	3.8%	S1280 to Humboldt	XS541221>300307>\$1
635034	CLRND 5 161.0	560001	NODAWAYCO 161.0	1	153	146.3	146.6	3.8%	S1280 to Humboldt	XS541209>541241>\$1
635034	CLRND 5 161.0	560001	NODAWAYCO 161.0	1	153	146.3	146.6	3.8%	S1280 to Humboldt	XS541205>541237>\$1
635034	CLRND 5 161.0	560001	NODAWAYCO 161.0	1	153	146.3	146.6	3.8%	S1280 to Humboldt	XS631048>636300>\$1

635034	CLRND 5	161.0	560001	NODAWAYCO	161.0	1	153	146.3	146.6	3.8%	S1399 to Humboldt	CB1233-BUS
635034	CLRND 5	161.0	560001	NODAWAYCO	161.0	1	153	146.4	146.6	3.8%	S975 (Humboldt) T4 161-69	XS635200>652564>\$1
635034	CLRND 5	161.0	560001	NODAWAYCO	161.0	1	153	146.2	146.5	4.8%	S1399 to Humboldt	MC1232-06-78
635034	CLRND 5	161.0	560001	NODAWAYCO	161.0	1	153	146.2	146.5	4.8%	S1399 to Humboldt	XS533041>532725>\$1
635034	CLRND 5	161.0	560001	NODAWAYCO	161.0	1	153	146.2	146.5	4.8%	S1399 to Humboldt	XS533040>532721>\$1
635034	CLRND 5	161.0	560001	NODAWAYCO	161.0	1	153	146.2	146.5	4.8%	S1399 to Humboldt	XS533249>532662>\$1
635034	CLRND 5	161.0	560001	NODAWAYCO	161.0	1	153	146.2	146.5	4.8%	S1399 to Humboldt	XS652603>652561>\$1
635034	CLRND 5	161.0	560001	NODAWAYCO	161.0	1	153	146.2	146.5	4.8%	S1399 to Humboldt	CB1286-BUS
635034	CLRND 5	161.0	560001	NODAWAYCO	161.0	1	153	146.2	146.5	4.8%	S1399 to Humboldt	CB923-BUSPXM
635034	CLRND 5	161.0	560001	NODAWAYCO	161.0	1	153	146.2	146.5	4.8%	S1399 to Humboldt	CB919-BUS
635034	CLRND 5	161.0	560001	NODAWAYCO	161.0	1	153	146.1	146.5	4.8%	S1399 to Humboldt	CB912-BUS
635034	CLRND 5	161.0	560001	NODAWAYCO	161.0	1	153	146.2	146.5	4.8%	S1399 to Humboldt	CB995-BUS938
635034	CLRND 5	161.0	560001	NODAWAYCO	161.0	1	153	146.2	146.5	4.8%	S1399 to Humboldt	XS541255>541170>\$1
635034	CLRND 5	161.0	560001	NODAWAYCO	161.0	1	153	146.2	146.5	4.8%	S1399 to Humboldt	XS533422>532694>\$1
635034	CLRND 5	161.0	560001	NODAWAYCO	161.0	1	153	146.2	146.5	4.8%	S1399 to Humboldt	XS533413>533422>\$1
635034	CLRND 5	161.0	560001	NODAWAYCO	161.0	1	153	146.2	146.5	3.8%	S1280 to Humboldt	XS635200>652564>\$1
635034	CLRND 5	161.0	560001	NODAWAYCO	161.0	1	153	146.2	146.5	3.8%	S1280 to Humboldt	XS635690>635693>\$3
635034	CLRND 5	161.0	560001	NODAWAYCO	161.0	1	153	146.2	146.5	3.8%	S1280 to Humboldt	XS635631>635632>\$1
635034	CLRND 5	161.0	560001	NODAWAYCO	161.0	1	153	146.2	146.5	3.8%	S1280 to Humboldt	XS631138>601034>\$1
635034	CLRND 5	161.0	560001	NODAWAYCO	161.0	1	153	146.2	146.5	3.8%	S1280 to Humboldt	XS640070>640071>\$1
635034	CLRND 5	161.0	560001	NODAWAYCO	161.0	1	153	146.2	146.5	3.8%	S1280 to Humboldt	XS640054>640176>\$1
635034	CLRND 5	161.0	560001	NODAWAYCO	161.0	1	153	146.2	146.5	3.8%	S1280 to Humboldt	XS640176>640177>\$1
635034	CLRND 5	161.0	560001	NODAWAYCO	161.0	1	153	146.2	146.5	3.8%	S1280 to Humboldt	XS640256>640258>\$1
635034	CLRND 5	161.0	560001	NODAWAYCO	161.0	1	153	146.2	146.5	3.8%	S1280 to Humboldt	XS640192>640193>\$1
635034	CLRND 5	161.0	560001	NODAWAYCO	161.0	1	153	146.2	146.5	3.8%	S1280 to Humboldt	XS640259>640260>643095\$1
635034	CLRND 5	161.0	560001	NODAWAYCO	161.0	1	153	146.2	146.5	3.8%	S1280 to Humboldt	XS641085>641095>\$1
635034	CLRND 5	161.0	560001	NODAWAYCO	161.0	1	153	146.2	146.5	3.8%	S1280 to Humboldt	XS640277>640312>\$1

635034	CLRNDA 5	161.0	560001	NODAWAYCO	161.0	1	153	146.2	146.5	3.8%	S1280 to Humboldt	XS640321>640322>\$1
635034	CLRNDA 5	161.0	560001	NODAWAYCO	161.0	1	153	146.2	146.5	3.8%	S1280 to Humboldt	XS640206>640207>\$1
635034	CLRNDA 5	161.0	560001	NODAWAYCO	161.0	1	153	146.2	146.5	3.8%	S1280 to Humboldt	XS640201>640202>\$1
635034	CLRNDA 5	161.0	560001	NODAWAYCO	161.0	1	153	146.2	146.5	3.8%	S1280 to Humboldt	XS640383>640384>\$1
635034	CLRNDA 5	161.0	560001	NODAWAYCO	161.0	1	153	146.2	146.5	3.8%	S1280 to Humboldt	XS645100>645104>\$1
635034	CLRNDA 5	161.0	560001	NODAWAYCO	161.0	1	153	146.2	146.5	3.8%	S1280 to Humboldt	XS650273>650373>650573\$1
635034	CLRNDA 5	161.0	560001	NODAWAYCO	161.0	1	153	146.2	146.5	3.8%	S1280 to Humboldt	XS647904>647906>\$1
635034	CLRNDA 5	161.0	560001	NODAWAYCO	161.0	1	153	146.2	146.5	3.8%	S1280 to Humboldt	XS650272>650372>650572\$1
635034	CLRNDA 5	161.0	560001	NODAWAYCO	161.0	1	153	146.2	146.5	3.8%	S1280 to Humboldt	XS650262>650462>650662\$1
635034	CLRNDA 5	161.0	560001	NODAWAYCO	161.0	1	153	146.2	146.5	3.8%	S1280 to Humboldt	XS650262>650362>650562\$1
635034	CLRNDA 5	161.0	560001	NODAWAYCO	161.0	1	153	146.2	146.5	3.8%	S1280 to Humboldt	XS646201>646229>\$1
635034	CLRNDA 5	161.0	560001	NODAWAYCO	161.0	1	153	146.2	146.5	3.8%	S1280 to Humboldt	XS650228>650328>650528\$1
635034	CLRNDA 5	161.0	560001	NODAWAYCO	161.0	1	153	146.2	146.5	3.8%	S1280 to Humboldt	XS650216>650316>650516\$1
635034	CLRNDA 5	161.0	560001	NODAWAYCO	161.0	1	153	146.2	146.5	3.8%	S1280 to Humboldt	XS650208>650408>650608\$1
635034	CLRNDA 5	161.0	560001	NODAWAYCO	161.0	1	153	146.2	146.5	3.8%	S1280 to Humboldt	XS300061>300519>\$1
635034	CLRNDA 5	161.0	560001	NODAWAYCO	161.0	1	153	146.2	146.5	3.8%	S1280 to Humboldt	S979TAP
635034	CLRNDA 5	161.0	560001	NODAWAYCO	161.0	1	153	146.2	146.5	3.8%	S1280 to Humboldt	XS300030>300015>\$1
635034	CLRNDA 5	161.0	560001	NODAWAYCO	161.0	1	153	146.2	146.5	3.8%	S1280 to Humboldt	XS533332>539665>\$1
635034	CLRNDA 5	161.0	560001	NODAWAYCO	161.0	1	153	146.2	146.5	3.8%	S1280 to Humboldt	XS652522>652209>\$1
635034	CLRNDA 5	161.0	560001	NODAWAYCO	161.0	1	153	146.2	146.5	3.8%	S1280 to Humboldt	XS652609>659198>\$1
635034	CLRNDA 5	161.0	560001	NODAWAYCO	161.0	1	153	146.2	146.5	3.8%	S1280 to Humboldt	XS652521>652285>\$1
635034	CLRNDA 5	161.0	560001	NODAWAYCO	161.0	1	153	146.2	146.5	3.8%	S1280 to Humboldt	XS652500>652271>\$1
635034	CLRNDA 5	161.0	560001	NODAWAYCO	161.0	1	153	146.2	146.5	3.8%	S1280 to Humboldt	XS659236>659237>\$1
635034	CLRNDA 5	161.0	560001	NODAWAYCO	161.0	1	153	146.2	146.5	3.8%	S1280 to Humboldt	D-CIRCUIT#2B
635034	CLRNDA 5	161.0	560001	NODAWAYCO	161.0	1	153	146.2	146.5	3.8%	S1280 to Humboldt	LES7006
635034	CLRNDA 5	161.0	560001	NODAWAYCO	161.0	1	153	146.2	146.5	3.8%	S1280 to Humboldt	LES6908
635034	CLRNDA 5	161.0	560001	NODAWAYCO	161.0	1	153	146.2	146.5	3.8%	S1280 to Humboldt	LES6703

635034	CLRNDA 5 161.0	560001	NODAWAYCO 161.0	1	153	146.2	146.5	3.8%	S1280 to Humboldt	CB1206-32&T1
635034	CLRNDA 5 161.0	560001	NODAWAYCO 161.0	1	153	146.2	146.5	3.8%	S1280 to Humboldt	CB972-BUS
635034	CLRNDA 5 161.0	560001	NODAWAYCO 161.0	1	153	146.2	146.5	3.8%	S1280 to Humboldt	CB1201-29&86
635034	CLRNDA 5 161.0	560001	NODAWAYCO 161.0	1	153	146.2	146.5	3.8%	S1280 to Humboldt	LES0017
635034	CLRNDA 5 161.0	560001	NODAWAYCO 161.0	1	153	146.2	146.5	3.8%	S1280 to Humboldt	LES0011
635034	CLRNDA 5 161.0	560001	NODAWAYCO 161.0	1	153	146.2	146.5	3.8%	S1280 to Humboldt	CB906S-BT63
635034	CLRNDA 5 161.0	560001	NODAWAYCO 161.0	1	153	146.2	146.5	3.8%	S1280 to Humboldt	LES3805B
635034	CLRNDA 5 161.0	560001	NODAWAYCO 161.0	1	153	146.2	146.5	3.8%	S1280 to Humboldt	CB1250-11&97
635034	CLRNDA 5 161.0	560001	NODAWAYCO 161.0	1	153	146.2	146.5	3.8%	S1280 to Humboldt	CB1250-09&97
635034	CLRNDA 5 161.0	560001	NODAWAYCO 161.0	1	153	146.2	146.5	3.8%	S1280 to Humboldt	LES3302
635034	CLRNDA 5 161.0	560001	NODAWAYCO 161.0	1	153	146.2	146.5	3.8%	S1280 to Humboldt	CB909BUS&937
635034	CLRNDA 5 161.0	560001	NODAWAYCO 161.0	1	153	146.2	146.5	3.8%	S1280 to Humboldt	BKR-PLN-3310
635034	CLRNDA 5 161.0	560001	NODAWAYCO 161.0	1	153	146.2	146.5	3.8%	S1280 to Humboldt	CBFREM-B
635034	CLRNDA 5 161.0	560001	NODAWAYCO 161.0	1	153	146.2	146.5	3.8%	S1280 to Humboldt	LN-1156
635034	CLRNDA 5 161.0	560001	NODAWAYCO 161.0	1	153	146.2	146.5	3.8%	S1280 to Humboldt	CBFREM-D
635034	CLRNDA 5 161.0	560001	NODAWAYCO 161.0	1	153	146.2	146.5	3.8%	S1280 to Humboldt	CBFREM-C
635034	CLRNDA 5 161.0	560001	NODAWAYCO 161.0	1	153	146.2	146.5	3.8%	S1280 to Humboldt	MC1209-1250
635034	CLRNDA 5 161.0	560001	NODAWAYCO 161.0	1	153	146.2	146.5	3.8%	S1280 to Humboldt	XS541206>541211>\$1
635034	CLRNDA 5 161.0	560001	NODAWAYCO 161.0	1	153	146.2	146.5	3.8%	S1280 to Humboldt	XS541250>548808>\$1
635034	CLRNDA 5 161.0	560001	NODAWAYCO 161.0	1	153	146.2	146.5	3.8%	S1280 to Humboldt	XS541218>541233>\$1
635034	CLRNDA 5 161.0	560001	NODAWAYCO 161.0	1	153	146.2	146.5	3.8%	S1280 to Humboldt	XS541241>345409>\$1
635034	CLRNDA 5 161.0	560001	NODAWAYCO 161.0	1	153	146.3	146.5	3.8%	S1280 to Humboldt	XS541215>541247>\$1
635034	CLRNDA 5 161.0	560001	NODAWAYCO 161.0	1	153	146.2	146.5	3.8%	S1280 to Humboldt	XS560610>560611>\$1
635034	CLRNDA 5 161.0	560001	NODAWAYCO 161.0	1	153	146.2	146.5	3.8%	S1280 to Humboldt	XS560611>560612>\$1
635034	CLRNDA 5 161.0	560001	NODAWAYCO 161.0	1	153	146.2	146.5	3.8%	S1280 to Humboldt	XS613370>631043>\$1
635034	CLRNDA 5 161.0	560001	NODAWAYCO 161.0	1	153	146.2	146.5	3.8%	S1280 to Humboldt	XS631085>629099>\$1
635034	CLRNDA 5 161.0	560001	NODAWAYCO 161.0	1	153	146.2	146.5	3.8%	S1280 to Humboldt	XS543061>543062>\$1

635034	CLRND 5	161.0	560001	NODAWAYCO	161.0	1	153	146.2	146.5	3.8%	S1280 to Humboldt	XS631091>629106>\$1
635034	CLRND 5	161.0	560001	NODAWAYCO	161.0	1	153	146.2	146.5	3.8%	S1280 to Humboldt	XS631012>629102>\$1
635034	CLRND 5	161.0	560001	NODAWAYCO	161.0	1	153	146.2	146.5	3.8%	S1399 to Humboldt	XS645455>645456>\$1
635034	CLRND 5	161.0	560001	NODAWAYCO	161.0	1	153	146.1	146.5	3.8%	S1399 to Humboldt	CB1249-BUS
635034	CLRND 5	161.0	560001	NODAWAYCO	161.0	1	153	146.2	146.5	3.8%	S1399 to Humboldt	CB918-BUS
635034	CLRND 5	161.0	560001	NODAWAYCO	161.0	1	153	146.2	146.5	3.8%	S975 (Humboldt) T4 161-69	XS652536>652287>\$1
635034	CLRND 5	161.0	560001	NODAWAYCO	161.0	1	153	146.3	146.5	3.8%	S975 (Humboldt) T4 161-69	XS636230>636235>\$1
635034	CLRND 5	161.0	560001	NODAWAYCO	161.0	1	153	146.2	146.5	3.8%	S975 (Humboldt) T4 161-69	XS640080>640081>\$1
635034	CLRND 5	161.0	560001	NODAWAYCO	161.0	1	153	146.3	146.5	3.8%	S975 (Humboldt) T4 161-69	XS640365>640366>\$1
635034	CLRND 5	161.0	560001	NODAWAYCO	161.0	1	153	146.3	146.5	3.8%	S975 (Humboldt) T4 161-69	XS640413>640414>\$1
635034	CLRND 5	161.0	560001	NODAWAYCO	161.0	1	153	146.3	146.5	3.8%	S975 (Humboldt) T4 161-69	D-CIRCUIT#13
635034	CLRND 5	161.0	560001	NODAWAYCO	161.0	1	153	146.3	146.5	3.8%	S975 (Humboldt) T4 161-69	D-CIRCUIT#15
635034	CLRND 5	161.0	560001	NODAWAYCO	161.0	1	153	146.3	146.5	3.8%	S975 (Humboldt) T4 161-69	CB906N-6979
635034	CLRND 5	161.0	560001	NODAWAYCO	161.0	1	153	146.3	146.5	3.8%	S1280 to Humboldt	XS631097>629094>\$1
635034	CLRND 5	161.0	560001	NODAWAYCO	161.0	1	153	146.3	146.5	3.8%	S1280 to Humboldt	XS635653>635654>\$1
635034	CLRND 5	161.0	560001	NODAWAYCO	161.0	1	153	146.3	146.5	3.8%	S1280 to Humboldt	XS640109>640110>\$1
635034	CLRND 5	161.0	560001	NODAWAYCO	161.0	1	153	146.3	146.5	3.8%	S1280 to Humboldt	XS640144>640146>\$1
635034	CLRND 5	161.0	560001	NODAWAYCO	161.0	1	153	146.3	146.5	3.8%	S1280 to Humboldt	XS640078>640079>\$1
635034	CLRND 5	161.0	560001	NODAWAYCO	161.0	1	153	146.3	146.5	3.8%	S1280 to Humboldt	XS636635>636636>\$1
635034	CLRND 5	161.0	560001	NODAWAYCO	161.0	1	153	146.3	146.5	3.8%	S1280 to Humboldt	XS640105>640415>\$1
635034	CLRND 5	161.0	560001	NODAWAYCO	161.0	1	153	146.3	146.5	3.8%	S1280 to Humboldt	XS640200>640330>\$1
635034	CLRND 5	161.0	560001	NODAWAYCO	161.0	1	153	146.3	146.5	3.8%	S1280 to Humboldt	XS645001>645101>\$1
635034	CLRND 5	161.0	560001	NODAWAYCO	161.0	1	153	146.3	146.5	3.8%	S1280 to Humboldt	XS640375>640376>\$1
635034	CLRND 5	161.0	560001	NODAWAYCO	161.0	1	153	146.3	146.5	3.8%	S1280 to Humboldt	XS645022>645122>\$1
635034	CLRND 5	161.0	560001	NODAWAYCO	161.0	1	153	146.3	146.5	3.8%	S1280 to Humboldt	XS640256>640257>\$1
635034	CLRND 5	161.0	560001	NODAWAYCO	161.0	1	153	146.3	146.5	3.8%	S1280 to Humboldt	XS640397>640398>\$1

635034	CLRNDA 5	161.0	560001	NODAWAYCO	161.0	1	153	146.3	146.5	3.8%	S1280 to Humboldt	XS645023>645123>\$1
635034	CLRNDA 5	161.0	560001	NODAWAYCO	161.0	1	153	146.3	146.5	3.8%	S1280 to Humboldt	XS640392>640393>\$1
635034	CLRNDA 5	161.0	560001	NODAWAYCO	161.0	1	153	146.3	146.5	3.8%	S1280 to Humboldt	XS640252>659133>\$1
635034	CLRNDA 5	161.0	560001	NODAWAYCO	161.0	1	153	146.3	146.5	3.8%	S1280 to Humboldt	XS645024>645124>\$1
635034	CLRNDA 5	161.0	560001	NODAWAYCO	161.0	1	153	146.3	146.5	3.8%	S1280 to Humboldt	XS641084>641094>\$1
635034	CLRNDA 5	161.0	560001	NODAWAYCO	161.0	1	153	146.3	146.5	3.8%	S1280 to Humboldt	XS640383>640385>\$1
635034	CLRNDA 5	161.0	560001	NODAWAYCO	161.0	1	153	146.3	146.5	3.8%	S1280 to Humboldt	XS640316>640317>\$1
635034	CLRNDA 5	161.0	560001	NODAWAYCO	161.0	1	153	146.3	146.5	3.8%	S1280 to Humboldt	XS641083>641092>\$1
635034	CLRNDA 5	161.0	560001	NODAWAYCO	161.0	1	153	146.3	146.5	3.8%	S1280 to Humboldt	XS640272>640273>643171\$1
635034	CLRNDA 5	161.0	560001	NODAWAYCO	161.0	1	153	146.3	146.5	3.8%	S1280 to Humboldt	XS640196>640198>\$1
635034	CLRNDA 5	161.0	560001	NODAWAYCO	161.0	1	153	146.3	146.5	3.8%	S1280 to Humboldt	XS640220>640221>\$1
635034	CLRNDA 5	161.0	560001	NODAWAYCO	161.0	1	153	146.3	146.5	3.8%	S1280 to Humboldt	XS640208>640426>\$1
635034	CLRNDA 5	161.0	560001	NODAWAYCO	161.0	1	153	146.3	146.5	3.8%	S1280 to Humboldt	XS646206>647006>648306\$1
635034	CLRNDA 5	161.0	560001	NODAWAYCO	161.0	1	153	146.3	146.5	3.8%	S1280 to Humboldt	XS650283>650483>650683\$1
635034	CLRNDA 5	161.0	560001	NODAWAYCO	161.0	1	153	146.3	146.5	3.8%	S1280 to Humboldt	XS647107>647109>\$1
635034	CLRNDA 5	161.0	560001	NODAWAYCO	161.0	1	153	146.3	146.5	3.8%	S1280 to Humboldt	XS650284>650384>650584\$1
635034	CLRNDA 5	161.0	560001	NODAWAYCO	161.0	1	153	146.3	146.5	3.8%	S1280 to Humboldt	XS645456>645459>\$1
635034	CLRNDA 5	161.0	560001	NODAWAYCO	161.0	1	153	146.3	146.5	3.8%	S1280 to Humboldt	XS647904>647985>\$1
635034	CLRNDA 5	161.0	560001	NODAWAYCO	161.0	1	153	146.3	146.5	3.8%	S1280 to Humboldt	XS646222>646229>\$1
635034	CLRNDA 5	161.0	560001	NODAWAYCO	161.0	1	153	146.3	146.5	3.8%	S1280 to Humboldt	XS646216>646217>\$1
635034	CLRNDA 5	161.0	560001	NODAWAYCO	161.0	1	153	146.3	146.5	3.8%	S1280 to Humboldt	XS650283>650383>650583\$1
635034	CLRNDA 5	161.0	560001	NODAWAYCO	161.0	1	153	146.3	146.5	3.8%	S1280 to Humboldt	XS647426>647992>\$1
635034	CLRNDA 5	161.0	560001	NODAWAYCO	161.0	1	153	146.3	146.5	3.8%	S1280 to Humboldt	XS647079>647979>\$1
635034	CLRNDA 5	161.0	560001	NODAWAYCO	161.0	1	153	146.3	146.5	3.8%	S1280 to Humboldt	XS300042>300045>\$1
635034	CLRNDA 5	161.0	560001	NODAWAYCO	161.0	1	153	146.3	146.5	3.8%	S1280 to Humboldt	XS300030>300016>\$1
635034	CLRNDA 5	161.0	560001	NODAWAYCO	161.0	1	153	146.3	146.5	3.8%	S1280 to Humboldt	XS300030>300017>\$1
635034	CLRNDA 5	161.0	560001	NODAWAYCO	161.0	1	153	146.3	146.5	3.8%	S1280 to Humboldt	XS300101>549969>\$1

635034	CLRND 5	161.0	560001	NODAWAYCO	161.0	1	153	146.3	146.5	3.8%	S1280 to Humboldt	XS300076>300249>\$2
635034	CLRND 5	161.0	560001	NODAWAYCO	161.0	1	153	146.3	146.5	3.8%	S1280 to Humboldt	XS300076>300249>\$1
635034	CLRND 5	161.0	560001	NODAWAYCO	161.0	1	153	146.3	146.5	3.8%	S1280 to Humboldt	XS300057>344532>\$1
635034	CLRND 5	161.0	560001	NODAWAYCO	161.0	1	153	146.3	146.5	3.8%	S1280 to Humboldt	MC1216-917
635034	CLRND 5	161.0	560001	NODAWAYCO	161.0	1	153	146.3	146.5	3.8%	S1280 to Humboldt	XS300718>505472>\$1
635034	CLRND 5	161.0	560001	NODAWAYCO	161.0	1	153	146.3	146.5	3.8%	S1280 to Humboldt	XS300718>338120>\$1
635034	CLRND 5	161.0	560001	NODAWAYCO	161.0	1	153	146.3	146.5	3.8%	S1280 to Humboldt	XS301107>301124>\$1
635034	CLRND 5	161.0	560001	NODAWAYCO	161.0	1	153	146.3	146.5	3.8%	S1280 to Humboldt	XS300617>344815>\$1
635034	CLRND 5	161.0	560001	NODAWAYCO	161.0	1	153	146.3	146.5	3.8%	S1280 to Humboldt	XS300123>301107>\$1
635034	CLRND 5	161.0	560001	NODAWAYCO	161.0	1	153	146.3	146.5	3.8%	S1280 to Humboldt	XS533002>510422>\$1
635034	CLRND 5	161.0	560001	NODAWAYCO	161.0	1	153	146.3	146.5	3.8%	S1280 to Humboldt	XS533152>533165>\$1
635034	CLRND 5	161.0	560001	NODAWAYCO	161.0	1	153	146.3	146.5	3.8%	S1280 to Humboldt	XS533322>533337>\$1
635034	CLRND 5	161.0	560001	NODAWAYCO	161.0	1	153	146.3	146.5	3.8%	S1280 to Humboldt	XS533322>533338>\$1
635034	CLRND 5	161.0	560001	NODAWAYCO	161.0	1	153	146.3	146.5	3.8%	S1280 to Humboldt	XS659240>659300>\$1
635034	CLRND 5	161.0	560001	NODAWAYCO	161.0	1	153	146.3	146.5	3.8%	S1280 to Humboldt	XS652508>652552>\$1
635034	CLRND 5	161.0	560001	NODAWAYCO	161.0	1	153	146.3	146.5	3.8%	S1280 to Humboldt	XS659132>640303>\$1
635034	CLRND 5	161.0	560001	NODAWAYCO	161.0	1	153	146.3	146.5	3.8%	S1280 to Humboldt	XS652517>652230>\$1
635034	CLRND 5	161.0	560001	NODAWAYCO	161.0	1	153	146.3	146.5	3.8%	S1280 to Humboldt	XS652565>652562>\$1
635034	CLRND 5	161.0	560001	NODAWAYCO	161.0	1	153	146.3	146.5	3.8%	S1280 to Humboldt	CB961-BUS&NH
635034	CLRND 5	161.0	560001	NODAWAYCO	161.0	1	153	146.3	146.5	3.8%	S1280 to Humboldt	LN-1155
635034	CLRND 5	161.0	560001	NODAWAYCO	161.0	1	153	146.3	146.5	3.8%	S1280 to Humboldt	CB1214-BUS
635034	CLRND 5	161.0	560001	NODAWAYCO	161.0	1	153	146.3	146.5	3.8%	S1280 to Humboldt	LN-FIRTH
635034	CLRND 5	161.0	560001	NODAWAYCO	161.0	1	153	146.3	146.5	3.8%	S1280 to Humboldt	1297TARP
635034	CLRND 5	161.0	560001	NODAWAYCO	161.0	1	153	146.3	146.5	3.8%	S1280 to Humboldt	CB976-BUS
635034	CLRND 5	161.0	560001	NODAWAYCO	161.0	1	153	146.3	146.5	3.8%	S1280 to Humboldt	LES0015
635034	CLRND 5	161.0	560001	NODAWAYCO	161.0	1	153	146.3	146.5	3.8%	S1280 to Humboldt	XS541202>541250>\$1
635034	CLRND 5	161.0	560001	NODAWAYCO	161.0	1	153	146.3	146.5	3.8%	S1280 to Humboldt	XS541206>541233>\$1

635034	CLRNDA 5 161.0	560001	NODAWAYCO 161.0	1	153	146.3	146.5	3.8%	S1280 to Humboldt	XS542973>543027>\$1
635034	CLRNDA 5 161.0	560001	NODAWAYCO 161.0	1	153	146.3	146.5	3.8%	S1280 to Humboldt	XS541201>541202>541360\$1
635034	CLRNDA 5 161.0	560001	NODAWAYCO 161.0	1	153	146.3	146.5	3.8%	S1280 to Humboldt	XS541198>541200>\$1
635034	CLRNDA 5 161.0	560001	NODAWAYCO 161.0	1	153	146.3	146.5	3.8%	S1280 to Humboldt	XS543015>543027>\$1
635034	CLRNDA 5 161.0	560001	NODAWAYCO 161.0	1	153	146.3	146.5	3.8%	S1280 to Humboldt	XS541204>541221>\$1
635034	CLRNDA 5 161.0	560001	NODAWAYCO 161.0	1	153	146.3	146.5	3.8%	S1280 to Humboldt	XS541205>541211>\$1
635034	CLRNDA 5 161.0	560001	NODAWAYCO 161.0	1	153	146.3	146.5	3.8%	S1280 to Humboldt	XS542969>543050>\$1
635034	CLRNDA 5 161.0	560001	NODAWAYCO 161.0	1	153	146.3	146.5	3.8%	S1280 to Humboldt	XS542969>542994>\$1
635034	CLRNDA 5 161.0	560001	NODAWAYCO 161.0	1	153	146.3	146.5	3.8%	S1280 to Humboldt	XS542993>541210>\$1
635034	CLRNDA 5 161.0	560001	NODAWAYCO 161.0	1	153	146.3	146.5	3.8%	S1280 to Humboldt	XS631021>631022>\$1
635034	CLRNDA 5 161.0	560001	NODAWAYCO 161.0	1	153	146.3	146.5	3.8%	S1280 to Humboldt	XS631047>631154>\$1
635034	CLRNDA 5 161.0	560001	NODAWAYCO 161.0	1	153	146.3	146.5	3.8%	S1280 to Humboldt	XS631043>631045>\$1
635034	CLRNDA 5 161.0	560001	NODAWAYCO 161.0	1	153	146.3	146.5	3.8%	S1280 to Humboldt	XS631001>631004>\$1
635034	CLRNDA 5 161.0	560001	NODAWAYCO 161.0	1	153	146.3	146.5	3.8%	S1280 to Humboldt	XS631068>629121>\$1
635034	CLRNDA 5 161.0	560001	NODAWAYCO 161.0	1	153	146.3	146.5	3.8%	S1280 to Humboldt	XS631003>631030>\$1
635034	CLRNDA 5 161.0	560001	NODAWAYCO 161.0	1	153	146.3	146.5	3.8%	S1280 to Humboldt	XS631021>629096>\$1
635034	CLRNDA 5 161.0	560001	NODAWAYCO 161.0	1	153	146.3	146.5	3.8%	S975 (Humboldt) T4 161-69	XS650267>650467>650667\$1
635034	CLRNDA 5 161.0	560001	NODAWAYCO 161.0	1	153	146.3	146.5	3.8%	S975 (Humboldt) T4 161-69	XS652518>652251>\$1
635034	CLRNDA 5 161.0	560001	NODAWAYCO 161.0	1	153	146.3	146.5	3.8%	S975 (Humboldt) T4 161-69	XS659240>659301>\$1
635034	CLRNDA 5 161.0	560001	NODAWAYCO 161.0	1	153	146.3	146.5	3.8%	S975 (Humboldt) T4 161-69	XS652504>652225>\$1
635034	CLRNDA 5 161.0	560001	NODAWAYCO 161.0	1	153	146.3	146.5	3.8%	S975 (Humboldt) T4 161-69	XS635651>635653>\$1
635034	CLRNDA 5 161.0	560001	NODAWAYCO 161.0	1	153	146.3	146.5	3.8%	S975 (Humboldt) T4 161-69	XS640196>640197>\$1
635034	CLRNDA 5 161.0	560001	NODAWAYCO 161.0	1	153	146.3	146.5	3.8%	S975 (Humboldt) T4 161-69	XS641084>641097>\$1
635034	CLRNDA 5 161.0	560001	NODAWAYCO 161.0	1	153	146.3	146.5	3.8%	S975 (Humboldt) T4 161-69	XS640377>640378>643151\$1
635034	CLRNDA 5 161.0	560001	NODAWAYCO 161.0	1	153	146.3	146.5	3.8%	S975 (Humboldt) T4 161-69	LN-N-BEND
635034	CLRNDA 5 161.0	560001	NODAWAYCO 161.0	1	153	146.3	146.5	3.8%	S975 (Humboldt) T4 161-69	MC906-79-28

635034	CLRND 5 161.0	560001	NODAWAYCO 161.0	1	153	146.3	146.5	3.8%	S975 (Humboldt) T4 161-69	CB906S-69A
635034	CLRND 5 161.0	560001	NODAWAYCO 161.0	1	153	146.3	146.5	3.8%	S975 (Humboldt) T4 161-69	LES6705
635034	CLRND 5 161.0	560001	NODAWAYCO 161.0	1	153	146	146.4	4.8%	S1399 to Humboldt	XS635034>635035>\$1
635034	CLRND 5 161.0	560001	NODAWAYCO 161.0	1	153	146	146.4	4.8%	S1399 to Humboldt	XS635034>635035>\$2
635034	CLRND 5 161.0	560001	NODAWAYCO 161.0	1	153	146.1	146.4	4.8%	S1399 to Humboldt	XS533180>532672>\$1
635034	CLRND 5 161.0	560001	NODAWAYCO 161.0	1	153	146.1	146.4	4.8%	S1399 to Humboldt	CB1236-BUS
635034	CLRND 5 161.0	560001	NODAWAYCO 161.0	1	153	146.1	146.4	4.8%	S1399 to Humboldt	XS560621>560622>\$1
635034	CLRND 5 161.0	560001	NODAWAYCO 161.0	1	153	146.1	146.4	4.8%	S1399 to Humboldt	XS560620>560621>\$1
635034	CLRND 5 161.0	560001	NODAWAYCO 161.0	1	153	146.2	146.4	3.8%	S1280 to Humboldt	XS635601>635608>\$1
635034	CLRND 5 161.0	560001	NODAWAYCO 161.0	1	153	146.2	146.4	3.8%	S1280 to Humboldt	XS631107>635710>\$1
635034	CLRND 5 161.0	560001	NODAWAYCO 161.0	1	153	146.1	146.4	3.8%	S1280 to Humboldt	XS635633>638050>\$1
635034	CLRND 5 161.0	560001	NODAWAYCO 161.0	1	153	146.2	146.4	3.8%	S1280 to Humboldt	XS636050>636235>\$1
635034	CLRND 5 161.0	560001	NODAWAYCO 161.0	1	153	146.2	146.4	3.8%	S1280 to Humboldt	XS640169>640170>\$1
635034	CLRND 5 161.0	560001	NODAWAYCO 161.0	1	153	146.2	146.4	3.8%	S1280 to Humboldt	XS640171>640172>\$1
635034	CLRND 5 161.0	560001	NODAWAYCO 161.0	1	153	146.1	146.4	3.8%	S1280 to Humboldt	XS640080>640081>\$1
635034	CLRND 5 161.0	560001	NODAWAYCO 161.0	1	153	146.1	146.4	3.8%	S1280 to Humboldt	XS636620>636630>\$1
635034	CLRND 5 161.0	560001	NODAWAYCO 161.0	1	153	146.2	146.4	3.8%	S1280 to Humboldt	XS640248>640249>\$1
635034	CLRND 5 161.0	560001	NODAWAYCO 161.0	1	153	146.2	146.4	3.8%	S1280 to Humboldt	XS640402>640403>\$1
635034	CLRND 5 161.0	560001	NODAWAYCO 161.0	1	153	146.1	146.4	3.8%	S1280 to Humboldt	XS640287>640289>\$1
635034	CLRND 5 161.0	560001	NODAWAYCO 161.0	1	153	146.2	146.4	3.8%	S1280 to Humboldt	XS640411>640412>\$1
635034	CLRND 5 161.0	560001	NODAWAYCO 161.0	1	153	146.2	146.4	3.8%	S1280 to Humboldt	XS640265>640266>\$1
635034	CLRND 5 161.0	560001	NODAWAYCO 161.0	1	153	146.2	146.4	3.8%	S1280 to Humboldt	XS640293>640295>\$1
635034	CLRND 5 161.0	560001	NODAWAYCO 161.0	1	153	146.2	146.4	3.8%	S1280 to Humboldt	XS640377>646226>\$1
635034	CLRND 5 161.0	560001	NODAWAYCO 161.0	1	153	146.1	146.4	3.8%	S1280 to Humboldt	XS640338>640339>\$2
635034	CLRND 5 161.0	560001	NODAWAYCO 161.0	1	153	146.2	146.4	3.8%	S1280 to Humboldt	XS640353>640355>\$1
635034	CLRND 5 161.0	560001	NODAWAYCO 161.0	1	153	146.2	146.4	3.8%	S1280 to Humboldt	XS640355>640356>\$1
635034	CLRND 5 161.0	560001	NODAWAYCO 161.0	1	153	146.2	146.4	3.8%	S1280 to Humboldt	XS645100>646251>\$1

635034	CLRNDA 5 161.0	560001	NODAWAYCO 161.0	1	153	146.2	146.4	3.8%	S1280 to Humboldt	XS650238>650438>650638\$1
635034	CLRNDA 5 161.0	560001	NODAWAYCO 161.0	1	153	146.2	146.4	3.8%	S1280 to Humboldt	XS650238>650338>650538\$1
635034	CLRNDA 5 161.0	560001	NODAWAYCO 161.0	1	153	146.1	146.4	3.8%	S1280 to Humboldt	XS650233>650333>650533\$1
635034	CLRNDA 5 161.0	560001	NODAWAYCO 161.0	1	153	146.2	146.4	3.8%	S1280 to Humboldt	XS650260>650460>650660\$1
635034	CLRNDA 5 161.0	560001	NODAWAYCO 161.0	1	153	146.2	146.4	3.8%	S1280 to Humboldt	XS647108>647110>\$1
635034	CLRNDA 5 161.0	560001	NODAWAYCO 161.0	1	153	146.2	146.4	3.8%	S1280 to Humboldt	XS650260>650360>650560\$1
635034	CLRNDA 5 161.0	560001	NODAWAYCO 161.0	1	153	146.1	146.4	3.8%	S1280 to Humboldt	XS650271>650371>650571\$1
635034	CLRNDA 5 161.0	560001	NODAWAYCO 161.0	1	153	146.2	146.4	3.8%	S1280 to Humboldt	XS650256>650356>650556\$1
635034	CLRNDA 5 161.0	560001	NODAWAYCO 161.0	1	153	146.2	146.4	3.8%	S1280 to Humboldt	XS650256>650456>650656\$1
635034	CLRNDA 5 161.0	560001	NODAWAYCO 161.0	1	153	146.2	146.4	3.8%	S1280 to Humboldt	XS650255>650355>650555\$1
635034	CLRNDA 5 161.0	560001	NODAWAYCO 161.0	1	153	146.2	146.4	3.8%	S1280 to Humboldt	XS650258>650358>650558\$1
635034	CLRNDA 5 161.0	560001	NODAWAYCO 161.0	1	153	146.2	146.4	3.8%	S1280 to Humboldt	XS650258>650458>650658\$1
635034	CLRNDA 5 161.0	560001	NODAWAYCO 161.0	1	153	146.1	146.4	3.8%	S1280 to Humboldt	XS650205>650305>650505\$1
635034	CLRNDA 5 161.0	560001	NODAWAYCO 161.0	1	153	146.1	146.4	3.8%	S1280 to Humboldt	XS650114>650185>\$1
635034	CLRNDA 5 161.0	560001	NODAWAYCO 161.0	1	153	146.2	146.4	3.8%	S1280 to Humboldt	XS652397>659258>\$1
635034	CLRNDA 5 161.0	560001	NODAWAYCO 161.0	1	153	146.1	146.4	3.8%	S1280 to Humboldt	XS650217>650417>650617\$1
635034	CLRNDA 5 161.0	560001	NODAWAYCO 161.0	1	153	146.1	146.4	3.8%	S1280 to Humboldt	XS650217>650317>650517\$1
635034	CLRNDA 5 161.0	560001	NODAWAYCO 161.0	1	153	146.1	146.4	3.8%	S1280 to Humboldt	XS300046>300051>\$1
635034	CLRNDA 5 161.0	560001	NODAWAYCO 161.0	1	153	146.2	146.4	3.8%	S1280 to Humboldt	MC906-79-28
635034	CLRNDA 5 161.0	560001	NODAWAYCO 161.0	1	153	146.1	146.4	3.8%	S1280 to Humboldt	MC3456-59-16
635034	CLRNDA 5 161.0	560001	NODAWAYCO 161.0	1	153	146.1	146.4	3.8%	S1280 to Humboldt	XS300041>344327>\$1
635034	CLRNDA 5 161.0	560001	NODAWAYCO 161.0	1	153	146.1	146.4	3.8%	S1280 to Humboldt	S937NOBKR
635034	CLRNDA 5 161.0	560001	NODAWAYCO 161.0	1	153	146.2	146.4	3.8%	S1280 to Humboldt	XS532913>533217>532942\$1
635034	CLRNDA 5 161.0	560001	NODAWAYCO 161.0	1	153	146.1	146.4	3.8%	S1280 to Humboldt	XS532768>532774>\$1
635034	CLRNDA 5 161.0	560001	NODAWAYCO 161.0	1	153	146.1	146.4	3.8%	S1280 to Humboldt	XS300114>300010>\$1
635034	CLRNDA 5 161.0	560001	NODAWAYCO 161.0	1	153	146.1	146.4	3.8%	S1280 to Humboldt	XS300114>300115>\$1
635034	CLRNDA 5 161.0	560001	NODAWAYCO 161.0	1	153	146.2	146.4	3.8%	S1280 to Humboldt	XS533217>533331>\$1

635034	CLRND 5	161.0	560001	NODAWAYCO	161.0	1	153	146.2	146.4	3.8%	S1280 to Humboldt	XS652504>652225>\$1
635034	CLRND 5	161.0	560001	NODAWAYCO	161.0	1	153	146.1	146.4	3.8%	S1280 to Humboldt	XS652536>652287>\$1
635034	CLRND 5	161.0	560001	NODAWAYCO	161.0	1	153	146.2	146.4	3.8%	S1280 to Humboldt	XS652506>652571>\$1
635034	CLRND 5	161.0	560001	NODAWAYCO	161.0	1	153	146.2	146.4	3.8%	S1280 to Humboldt	XS652515>652284>\$1
635034	CLRND 5	161.0	560001	NODAWAYCO	161.0	1	153	146.2	146.4	3.8%	S1280 to Humboldt	XS652531>652242>\$1
635034	CLRND 5	161.0	560001	NODAWAYCO	161.0	1	153	146.2	146.4	3.8%	S1280 to Humboldt	XS652529>652537>\$1
635034	CLRND 5	161.0	560001	NODAWAYCO	161.0	1	153	146.2	146.4	3.8%	S1280 to Humboldt	LES7003
635034	CLRND 5	161.0	560001	NODAWAYCO	161.0	1	153	146.1	146.4	3.8%	S1280 to Humboldt	D-CIRCUIT#15
635034	CLRND 5	161.0	560001	NODAWAYCO	161.0	1	153	146.2	146.4	3.8%	S1280 to Humboldt	CB1226-98&TK
635034	CLRND 5	161.0	560001	NODAWAYCO	161.0	1	153	146.2	146.4	3.8%	S1280 to Humboldt	LES6705
635034	CLRND 5	161.0	560001	NODAWAYCO	161.0	1	153	146.1	146.4	3.8%	S1280 to Humboldt	CB1206-16&T1
635034	CLRND 5	161.0	560001	NODAWAYCO	161.0	1	153	146.2	146.4	3.8%	S1280 to Humboldt	LES0016
635034	CLRND 5	161.0	560001	NODAWAYCO	161.0	1	153	146.2	146.4	3.8%	S1280 to Humboldt	LES0013
635034	CLRND 5	161.0	560001	NODAWAYCO	161.0	1	153	146.1	146.4	3.8%	S1280 to Humboldt	CB1259-BUS81
635034	CLRND 5	161.0	560001	NODAWAYCO	161.0	1	153	146.1	146.4	3.8%	S1280 to Humboldt	LES3802A
635034	CLRND 5	161.0	560001	NODAWAYCO	161.0	1	153	146.2	146.4	3.8%	S1280 to Humboldt	CB994-BUS06N
635034	CLRND 5	161.0	560001	NODAWAYCO	161.0	1	153	146.1	146.4	3.8%	S1280 to Humboldt	CB985-BUS
635034	CLRND 5	161.0	560001	NODAWAYCO	161.0	1	153	146.2	146.4	3.8%	S1280 to Humboldt	MC1201-20-86
635034	CLRND 5	161.0	560001	NODAWAYCO	161.0	1	153	146.2	146.4	3.8%	S1280 to Humboldt	906N15-25-94
635034	CLRND 5	161.0	560001	NODAWAYCO	161.0	1	153	146.1	146.4	3.8%	S1280 to Humboldt	CBFREM-E
635034	CLRND 5	161.0	560001	NODAWAYCO	161.0	1	153	146.2	146.4	3.8%	S1280 to Humboldt	XS543015>543016>\$1
635034	CLRND 5	161.0	560001	NODAWAYCO	161.0	1	153	146.2	146.4	3.8%	S1280 to Humboldt	XS542965>542966>543649\$11
635034	CLRND 5	161.0	560001	NODAWAYCO	161.0	1	153	146.2	146.4	3.8%	S1280 to Humboldt	XS543028>541203>\$1
635034	CLRND 5	161.0	560001	NODAWAYCO	161.0	1	153	146.2	146.4	3.8%	S1280 to Humboldt	XS541215>541250>\$1
635034	CLRND 5	161.0	560001	NODAWAYCO	161.0	1	153	146.2	146.4	3.8%	S1280 to Humboldt	XS631074>631077>\$1
635034	CLRND 5	161.0	560001	NODAWAYCO	161.0	1	153	146.1	146.4	3.8%	S1280 to Humboldt	XS543062>300120>\$1
635034	CLRND 5	161.0	560001	NODAWAYCO	161.0	1	153	146.2	146.4	3.8%	S1280 to Humboldt	XS543062>543064>\$1

635034	CLRND 5 161.0	560001	NODAWAYCO 161.0	1	153	146.2	146.4	3.8%	S1280 to Humboldt	XS631062>630175>\$1
635034	CLRND 5 161.0	560001	NODAWAYCO 161.0	1	153	146.2	146.4	3.8%	S1280 to Humboldt	XS631063>630174>\$1
635034	CLRND 5 161.0	560001	NODAWAYCO 161.0	1	153	146.2	146.4	3.8%	S1280 to Humboldt	XS631071>629111>\$1
635034	CLRND 5 161.0	560001	NODAWAYCO 161.0	1	153	146.1	146.4	3.8%	S1399 to Humboldt	XS636620>636625>\$1
635034	CLRND 5 161.0	560001	NODAWAYCO 161.0	1	153	146.1	146.4	3.8%	S1399 to Humboldt	XS636625>636627>\$1
635034	CLRND 5 161.0	560001	NODAWAYCO 161.0	1	153	146.1	146.4	3.8%	S1399 to Humboldt	XS542995>542953>\$1
635034	CLRND 5 161.0	560001	NODAWAYCO 161.0	1	153	146.1	146.4	3.8%	S1399 to Humboldt	XS542995>542952>\$1
635034	CLRND 5 161.0	560001	NODAWAYCO 161.0	1	153	146.2	146.4	3.8%	S975 (Humboldt) T4 161-69	XS300041>344154>\$1
635034	CLRND 5 161.0	560001	NODAWAYCO 161.0	1	153	146.2	146.4	3.8%	S975 (Humboldt) T4 161-69	XS647016>647915>\$1
635034	CLRND 5 161.0	560001	NODAWAYCO 161.0	1	153	146.2	146.4	3.8%	S975 (Humboldt) T4 161-69	BKR-WAG-3004
635034	CLRND 5 161.0	560001	NODAWAYCO 161.0	1	153	146.2	146.4	3.8%	S975 (Humboldt) T4 161-69	CB1251-97&FC
635034	CLRND 5 161.0	560001	NODAWAYCO 161.0	1	153	146.2	146.4	3.8%	S975 (Humboldt) T4 161-69	CB906N-6994
635034	CLRND 5 161.0	560001	NODAWAYCO 161.0	1	153	146.2	146.4	3.8%	S975 (Humboldt) T4 161-69	CB902-BUS
635034	CLRND 5 161.0	560001	NODAWAYCO 161.0	1	153	145.9	146.3	4.8%	S1399 to Humboldt	XS635037>635038>\$1
635034	CLRND 5 161.0	560001	NODAWAYCO 161.0	1	153	146	146.3	4.8%	S1399 to Humboldt	XS635012>635039>\$1
635034	CLRND 5 161.0	560001	NODAWAYCO 161.0	1	153	146	146.3	4.8%	S1399 to Humboldt	XS640227>640230>\$1
635034	CLRND 5 161.0	560001	NODAWAYCO 161.0	1	153	146	146.3	4.8%	S1399 to Humboldt	XS532765>532772>\$1
635034	CLRND 5 161.0	560001	NODAWAYCO 161.0	1	153	146	146.3	4.8%	S1399 to Humboldt	LES0805B
635034	CLRND 5 161.0	560001	NODAWAYCO 161.0	1	153	146	146.3	4.8%	S1399 to Humboldt	LES0805A
635034	CLRND 5 161.0	560001	NODAWAYCO 161.0	1	153	146	146.3	4.8%	S1399 to Humboldt	XS542973>542961>\$1
635034	CLRND 5 161.0	560001	NODAWAYCO 161.0	1	153	146	146.3	3.8%	S1280 to Humboldt	XS636001>636050>\$1
635034	CLRND 5 161.0	560001	NODAWAYCO 161.0	1	153	146	146.3	3.8%	S1280 to Humboldt	XS631110>631111>\$1
635034	CLRND 5 161.0	560001	NODAWAYCO 161.0	1	153	146.1	146.3	3.8%	S1280 to Humboldt	XS631110>631115>\$1
635034	CLRND 5 161.0	560001	NODAWAYCO 161.0	1	153	146.1	146.3	3.8%	S1280 to Humboldt	XS635039>635041>\$1
635034	CLRND 5 161.0	560001	NODAWAYCO 161.0	1	153	146.1	146.3	3.8%	S1280 to Humboldt	XS640098>640099>\$1
635034	CLRND 5 161.0	560001	NODAWAYCO 161.0	1	153	146	146.3	3.8%	S1280 to Humboldt	XS636636>636672>\$1

635034	CLRND 5 161.0	560001	NODAWAYCO 161.0	1	153	146.1	146.3	3.8%	S1280 to Humboldt	XS640063>640416>\$1
635034	CLRND 5 161.0	560001	NODAWAYCO 161.0	1	153	146	146.3	3.8%	S1280 to Humboldt	XS640072>640073>\$1
635034	CLRND 5 161.0	560001	NODAWAYCO 161.0	1	153	146.1	146.3	3.8%	S1280 to Humboldt	XS640051>640052>\$1
635034	CLRND 5 161.0	560001	NODAWAYCO 161.0	1	153	146.1	146.3	3.8%	S1280 to Humboldt	XS636225>636240>\$1
635034	CLRND 5 161.0	560001	NODAWAYCO 161.0	1	153	146.1	146.3	3.8%	S1280 to Humboldt	XS636230>636240>\$1
635034	CLRND 5 161.0	560001	NODAWAYCO 161.0	1	153	146.1	146.3	3.8%	S1280 to Humboldt	XS636635>636640>\$1
635034	CLRND 5 161.0	560001	NODAWAYCO 161.0	1	153	146	146.3	3.8%	S1280 to Humboldt	XS640246>652302>\$1
635034	CLRND 5 161.0	560001	NODAWAYCO 161.0	1	153	146.1	146.3	3.8%	S1280 to Humboldt	XS640400>640401>\$1
635034	CLRND 5 161.0	560001	NODAWAYCO 161.0	1	153	146.1	146.3	3.8%	S1280 to Humboldt	XS640331>640332>\$1
635034	CLRND 5 161.0	560001	NODAWAYCO 161.0	1	153	146	146.3	3.8%	S1280 to Humboldt	XS640372>640373>\$1
635034	CLRND 5 161.0	560001	NODAWAYCO 161.0	1	153	146.1	146.3	3.8%	S1280 to Humboldt	XS640293>640294>\$1
635034	CLRND 5 161.0	560001	NODAWAYCO 161.0	1	153	146	146.3	3.8%	S1280 to Humboldt	XS640313>640314>\$1
635034	CLRND 5 161.0	560001	NODAWAYCO 161.0	1	153	146	146.3	3.8%	S1280 to Humboldt	XS640212>640213>\$1
635034	CLRND 5 161.0	560001	NODAWAYCO 161.0	1	153	146.1	146.3	3.8%	S1280 to Humboldt	XS650240>650252>\$1
635034	CLRND 5 161.0	560001	NODAWAYCO 161.0	1	153	146.1	146.3	3.8%	S1280 to Humboldt	XS650252>650352>650552\$1
635034	CLRND 5 161.0	560001	NODAWAYCO 161.0	1	153	146.1	146.3	3.8%	S1280 to Humboldt	XS650251>650351>650551\$1
635034	CLRND 5 161.0	560001	NODAWAYCO 161.0	1	153	146	146.3	3.8%	S1280 to Humboldt	XS646214>646287>\$1
635034	CLRND 5 161.0	560001	NODAWAYCO 161.0	1	153	146.1	146.3	3.8%	S1280 to Humboldt	XS650230>650330>\$1
635034	CLRND 5 161.0	560001	NODAWAYCO 161.0	1	153	146	146.3	3.8%	S1280 to Humboldt	XS650229>650329>650529\$1
635034	CLRND 5 161.0	560001	NODAWAYCO 161.0	1	153	146.1	146.3	3.8%	S1280 to Humboldt	XS650238>650251>\$1
635034	CLRND 5 161.0	560001	NODAWAYCO 161.0	1	153	146.1	146.3	3.8%	S1280 to Humboldt	XS647100>647900>\$1
635034	CLRND 5 161.0	560001	NODAWAYCO 161.0	1	153	146.1	146.3	3.8%	S1280 to Humboldt	XS650259>650359>650559\$1
635034	CLRND 5 161.0	560001	NODAWAYCO 161.0	1	153	146	146.3	3.8%	S1280 to Humboldt	XS650270>650370>650570\$1
635034	CLRND 5 161.0	560001	NODAWAYCO 161.0	1	153	146.1	146.3	3.8%	S1280 to Humboldt	XS652302>659240>\$1
635034	CLRND 5 161.0	560001	NODAWAYCO 161.0	1	153	146.1	146.3	3.8%	S1280 to Humboldt	XS650219>650319>650519\$1
635034	CLRND 5 161.0	560001	NODAWAYCO 161.0	1	153	146	146.3	3.8%	S1280 to Humboldt	XS300041>344154>\$1
635034	CLRND 5 161.0	560001	NODAWAYCO 161.0	1	153	146.1	146.3	3.8%	S1280 to Humboldt	XS300098>300304>548824\$2

635034	CLRND 5	161.0	560001	NODAWAYCO	161.0	1	153	146.1	146.3	3.8%	S1280 to Humboldt	XS300098>300304>548823\$1
635034	CLRND 5	161.0	560001	NODAWAYCO	161.0	1	153	146.1	146.3	3.8%	S1280 to Humboldt	MC1299SOUTH
635034	CLRND 5	161.0	560001	NODAWAYCO	161.0	1	153	146	146.3	3.8%	S1280 to Humboldt	XS300040>300054>\$1
635034	CLRND 5	161.0	560001	NODAWAYCO	161.0	1	153	146.1	146.3	3.8%	S1280 to Humboldt	XS532800>532801>\$1
635034	CLRND 5	161.0	560001	NODAWAYCO	161.0	1	153	146	146.3	3.8%	S1280 to Humboldt	XS652505>652229>652227\$1
635034	CLRND 5	161.0	560001	NODAWAYCO	161.0	1	153	146	146.3	3.8%	S1280 to Humboldt	XS652524>659250>\$1
635034	CLRND 5	161.0	560001	NODAWAYCO	161.0	1	153	146.1	146.3	3.8%	S1280 to Humboldt	XS652503>652224>\$1
635034	CLRND 5	161.0	560001	NODAWAYCO	161.0	1	153	146	146.3	3.8%	S1280 to Humboldt	XS652502>652254>652255\$1
635034	CLRND 5	161.0	560001	NODAWAYCO	161.0	1	153	146.1	146.3	3.8%	S1280 to Humboldt	XS652614>659196>\$1
635034	CLRND 5	161.0	560001	NODAWAYCO	161.0	1	153	146	146.3	3.8%	S1280 to Humboldt	XS652525>652286>\$1
635034	CLRND 5	161.0	560001	NODAWAYCO	161.0	1	153	146.1	146.3	3.8%	S1280 to Humboldt	D-CIRCUIT#1B
635034	CLRND 5	161.0	560001	NODAWAYCO	161.0	1	153	146.1	146.3	3.8%	S1280 to Humboldt	D-CIR #14A
635034	CLRND 5	161.0	560001	NODAWAYCO	161.0	1	153	146.1	146.3	3.8%	S1280 to Humboldt	LES1502
635034	CLRND 5	161.0	560001	NODAWAYCO	161.0	1	153	146.1	146.3	3.8%	S1280 to Humboldt	CB1341-BUS
635034	CLRND 5	161.0	560001	NODAWAYCO	161.0	1	153	146.1	146.3	3.8%	S1280 to Humboldt	LES0009
635034	CLRND 5	161.0	560001	NODAWAYCO	161.0	1	153	146.1	146.3	3.8%	S1280 to Humboldt	CB1299-BUS
635034	CLRND 5	161.0	560001	NODAWAYCO	161.0	1	153	146.1	146.3	3.8%	S1280 to Humboldt	LES3002
635034	CLRND 5	161.0	560001	NODAWAYCO	161.0	1	153	146.1	146.3	3.8%	S1280 to Humboldt	LES3003B
635034	CLRND 5	161.0	560001	NODAWAYCO	161.0	1	153	146.1	146.3	3.8%	S1280 to Humboldt	LES6202
635034	CLRND 5	161.0	560001	NODAWAYCO	161.0	1	153	146.1	146.3	3.8%	S1280 to Humboldt	LES0014
635034	CLRND 5	161.0	560001	NODAWAYCO	161.0	1	153	146	146.3	3.8%	S1280 to Humboldt	CB1251-97&FC
635034	CLRND 5	161.0	560001	NODAWAYCO	161.0	1	153	146.1	146.3	3.8%	S1280 to Humboldt	LES3803A
635034	CLRND 5	161.0	560001	NODAWAYCO	161.0	1	153	146.1	146.3	3.8%	S1280 to Humboldt	LES3806B
635034	CLRND 5	161.0	560001	NODAWAYCO	161.0	1	153	146.1	146.3	3.8%	S1280 to Humboldt	LES6201
635034	CLRND 5	161.0	560001	NODAWAYCO	161.0	1	153	146.1	146.3	3.8%	S1280 to Humboldt	LES3301
635034	CLRND 5	161.0	560001	NODAWAYCO	161.0	1	153	146	146.3	3.8%	S1280 to Humboldt	BKR-WAG-3004
635034	CLRND 5	161.0	560001	NODAWAYCO	161.0	1	153	146.1	146.3	3.8%	S1280 to Humboldt	LN-1161

635034	CLRNDA 5 161.0	560001	NODAWAYCO 161.0	1	153	146	146.3	3.8%	S1280 to Humboldt	1211-50-LS
635034	CLRNDA 5 161.0	560001	NODAWAYCO 161.0	1	153	146.1	146.3	3.8%	S1280 to Humboldt	XS542968>541198>\$1
635034	CLRNDA 5 161.0	560001	NODAWAYCO 161.0	1	153	146.1	146.3	3.8%	S1280 to Humboldt	XS542965>542977>\$1
635034	CLRNDA 5 161.0	560001	NODAWAYCO 161.0	1	153	146	146.3	3.8%	S1280 to Humboldt	XS631002>629108>\$1
635034	CLRNDA 5 161.0	560001	NODAWAYCO 161.0	1	153	146.1	146.3	3.8%	S1280 to Humboldt	XS631007>631030>\$1
635034	CLRNDA 5 161.0	560001	NODAWAYCO 161.0	1	153	146.1	146.3	3.8%	S1280 to Humboldt	XS631081>631107>\$1
635034	CLRNDA 5 161.0	560001	NODAWAYCO 161.0	1	153	146	146.3	3.8%	S1399 to Humboldt	MC1206-01-CB
635034	CLRNDA 5 161.0	560001	NODAWAYCO 161.0	1	153	146	146.3	3.8%	Kelly to GEN2007-015	XS640139>645458>\$1
635034	CLRNDA 5 161.0	560001	NODAWAYCO 161.0	1	153	146.1	146.3	3.8%	Kelly to GEN2007-015	BKR-HMB-1604
635034	CLRNDA 5 161.0	560001	NODAWAYCO 161.0	1	153	146.1	146.3	3.8%	S975 (Humboldt) T4 161-69	XS635003>635005>\$1
635034	CLRNDA 5 161.0	560001	NODAWAYCO 161.0	1	153	146.1	146.3	3.8%	S975 (Humboldt) T4 161-69	XS635680>635690>\$1
635034	CLRNDA 5 161.0	560001	NODAWAYCO 161.0	1	153	146.1	146.3	3.8%	S975 (Humboldt) T4 161-69	XS635640>635650>\$1
635034	CLRNDA 5 161.0	560001	NODAWAYCO 161.0	1	153	146.1	146.3	3.8%	S975 (Humboldt) T4 161-69	S1210 AUTOV3
635034	CLRNDA 5 161.0	560001	NODAWAYCO 161.0	1	153	146.1	146.3	3.8%	S975 (Humboldt) T4 161-69	XS631110>631115>\$2
635034	CLRNDA 5 161.0	560001	NODAWAYCO 161.0	1	153	146.1	146.3	3.8%	S975 (Humboldt) T4 161-69	XS631078>630395>\$1
635034	CLRNDA 5 161.0	560001	NODAWAYCO 161.0	1	153	146.1	146.3	3.8%	S975 (Humboldt) T4 161-69	XS541218>541156>\$1
635034	CLRNDA 5 161.0	560001	NODAWAYCO 161.0	1	153	146.1	146.3	3.8%	S975 (Humboldt) T4 161-69	XS541218>541157>\$1
635034	CLRNDA 5 161.0	560001	NODAWAYCO 161.0	1	153	146.1	146.3	3.8%	S975 (Humboldt) T4 161-69	XS541218>541155>\$1
635034	CLRNDA 5 161.0	560001	NODAWAYCO 161.0	1	153	146.1	146.3	3.8%	S975 (Humboldt) T4 161-69	XS541218>541158>\$1
635034	CLRNDA 5 161.0	560001	NODAWAYCO 161.0	1	153	146	146.3	3.8%	S975 (Humboldt) T4 161-69	XS533248>532661>\$1
635034	CLRNDA 5 161.0	560001	NODAWAYCO 161.0	1	153	146.1	146.3	3.8%	S1280 to Humboldt	XS300076>300107>\$1
635034	CLRNDA 5 161.0	560001	NODAWAYCO 161.0	1	153	145.9	146.2	4.8%	S1399 to Humboldt	XS635001>635012>\$1
635034	CLRNDA 5 161.0	560001	NODAWAYCO 161.0	1	153	146	146.2	3.8%	S1280 to Humboldt	XS631117>635670>\$1
635034	CLRNDA 5 161.0	560001	NODAWAYCO 161.0	1	153	145.9	146.2	3.8%	S1280 to Humboldt	XS533248>532661>\$1
635034	CLRNDA 5 161.0	560001	NODAWAYCO 161.0	1	153	145.9	146.2	3.8%	S1280 to Humboldt	906S15-25-94

635034	CLRND 5	161.0	560001	NODAWAYCO	161.0	1	153	145.9	146.2	3.8%	S1280 to Humboldt	CB994-BUS065
635034	CLRND 5	161.0	560001	NODAWAYCO	161.0	1	153	145.9	146.2	3.8%	S1280 to Humboldt	BKR-MOR-3306
635034	CLRND 5	161.0	560001	NODAWAYCO	161.0	1	153	145.9	146.2	3.8%	S1399 to Humboldt	XS635001>646206>\$1
635034	CLRND 5	161.0	560001	NODAWAYCO	161.0	1	153	146	146.2	3.8%	S1399 to Humboldt	XS532913>560610>\$1
635034	CLRND 5	161.0	560001	NODAWAYCO	161.0	1	153	145.9	146.2	3.8%	S1399 to Humboldt	CB1206T2SC45
635034	CLRND 5	161.0	560001	NODAWAYCO	161.0	1	153	146	146.2	3.8%	Kelly to GEN2007-015	XS640234>646399>\$1
635034	CLRND 5	161.0	560001	NODAWAYCO	161.0	1	153	146	146.2	3.8%	Kelly to GEN2007-015	CB1399-BUS
635034	CLRND 5	161.0	560001	NODAWAYCO	161.0	1	153	146	146.2	3.8%	S1280 to Humboldt	XS636000>636001>636002\$1
635034	CLRND 5	161.0	560001	NODAWAYCO	161.0	1	153	145.9	146.2	3.8%	S1280 to Humboldt	XS646281>646287>\$1
635034	CLRND 5	161.0	560001	NODAWAYCO	161.0	1	153	146	146.2	3.8%	S1280 to Humboldt	XS652551>652298>\$1
635034	CLRND 5	161.0	560001	NODAWAYCO	161.0	1	153	145.9	146.2	3.8%	S1280 to Humboldt	XS652534>652290>\$1
635034	CLRND 5	161.0	560001	NODAWAYCO	161.0	1	153	146	146.2	3.8%	S1280 to Humboldt	XS659185>659243>\$1
635034	CLRND 5	161.0	560001	NODAWAYCO	161.0	1	153	146	146.2	3.8%	S1280 to Humboldt	1281LINBUS
635034	CLRND 5	161.0	560001	NODAWAYCO	161.0	1	153	146	146.2	3.8%	S1280 to Humboldt	CB906S69B994
635034	CLRND 5	161.0	560001	NODAWAYCO	161.0	1	153	146	146.2	3.8%	S1280 to Humboldt	D-CIRCUIT#16
635034	CLRND 5	161.0	560001	NODAWAYCO	161.0	1	153	146	146.2	3.8%	S1280 to Humboldt	CB924-BUS
635034	CLRND 5	161.0	560001	NODAWAYCO	161.0	1	153	146	146.2	3.8%	S1280 to Humboldt	CB914-BUS
635034	CLRND 5	161.0	560001	NODAWAYCO	161.0	1	153	146	146.2	3.8%	S1280 to Humboldt	CB1281-BUS
635034	CLRND 5	161.0	560001	NODAWAYCO	161.0	1	153	146	146.2	3.8%	S1280 to Humboldt	CB907-BUS
635034	CLRND 5	161.0	560001	NODAWAYCO	161.0	1	153	146	146.2	3.8%	S1280 to Humboldt	XS631074>629110>\$1
635034	CLRND 5	161.0	560001	NODAWAYCO	161.0	1	153	146	146.2	3.8%	S1280 to Humboldt	XS560332>640208>\$1
635034	CLRND 5	161.0	560001	NODAWAYCO	161.0	1	153	146	146.2	3.8%	S975 (Humboldt) T4 161-69	XS300103>300006>\$1
635034	CLRND 5	161.0	560001	NODAWAYCO	161.0	1	153	146	146.2	3.8%	S975 (Humboldt) T4 161-69	CB904BUS&985
635034	CLRND 5	161.0	560001	NODAWAYCO	161.0	1	153	145.8	146.1	4.8%	S1399 to Humboldt	XS300049>300120>\$1
635034	CLRND 5	161.0	560001	NODAWAYCO	161.0	1	153	145.9	146.1	3.8%	S1280 to Humboldt	XS640163>640164>\$1
635034	CLRND 5	161.0	560001	NODAWAYCO	161.0	1	153	145.9	146.1	3.8%	S1280 to Humboldt	XS640149>640150>\$1
635034	CLRND 5	161.0	560001	NODAWAYCO	161.0	1	153	145.8	146.1	3.8%	S1280 to Humboldt	XS652397>659259>\$1

635034	CLRND 5	161.0	560001	NODAWAYCO	161.0	1	153	145.8	146.1	3.8%	S1280 to Humboldt	XS300046>300007>\$1
635034	CLRND 5	161.0	560001	NODAWAYCO	161.0	1	153	145.8	146.1	3.8%	S1280 to Humboldt	S1217 AUTOV3
635034	CLRND 5	161.0	560001	NODAWAYCO	161.0	1	153	145.8	146.1	3.8%	S1280 to Humboldt	MC1211-20-LS
635034	CLRND 5	161.0	560001	NODAWAYCO	161.0	1	153	145.9	146.1	3.8%	S1280 to Humboldt	MC1211-1250
635034	CLRND 5	161.0	560001	NODAWAYCO	161.0	1	153	145.8	146.1	3.8%	S1280 to Humboldt	XS300103>300006>\$1
635034	CLRND 5	161.0	560001	NODAWAYCO	161.0	1	153	145.8	146.1	3.8%	S1280 to Humboldt	CB916-BUS
635034	CLRND 5	161.0	560001	NODAWAYCO	161.0	1	153	145.9	146.1	3.8%	S1280 to Humboldt	D-CIR #17A
635034	CLRND 5	161.0	560001	NODAWAYCO	161.0	1	153	145.9	146.1	3.8%	S1280 to Humboldt	CB3451-RN&T4
635034	CLRND 5	161.0	560001	NODAWAYCO	161.0	1	153	145.9	146.1	3.8%	S1280 to Humboldt	CB904BUS&985
635034	CLRND 5	161.0	560001	NODAWAYCO	161.0	1	153	145.9	146.1	3.8%	S1280 to Humboldt	LES1504A
635034	CLRND 5	161.0	560001	NODAWAYCO	161.0	1	153	145.9	146.1	3.8%	S1280 to Humboldt	CB900-BUS
635034	CLRND 5	161.0	560001	NODAWAYCO	161.0	1	153	145.8	146.1	3.8%	S1280 to Humboldt	CB902BUS&937
635034	CLRND 5	161.0	560001	NODAWAYCO	161.0	1	153	145.9	146.1	3.8%	S1280 to Humboldt	LES3303
635034	CLRND 5	161.0	560001	NODAWAYCO	161.0	1	153	145.8	146.1	3.8%	S1280 to Humboldt	XS541221>541350>\$1
635034	CLRND 5	161.0	560001	NODAWAYCO	161.0	1	153	145.9	146.1	3.8%	S975 (Humboldt) T4 161-69	XS533180>532671>\$1
635034	CLRND 5	161.0	560001	NODAWAYCO	161.0	1	153	145.9	146.1	3.8%	S975 (Humboldt) T4 161-69	161T37BK1OR2
635034	CLRND 5	161.0	560001	NODAWAYCO	161.0	1	153	145.7	146	4.8%	S1399 to Humboldt	XS542968>542981>\$1
635034	CLRND 5	161.0	560001	NODAWAYCO	161.0	1	153	145.7	146	4.8%	S1399 to Humboldt	XS541225>541163>\$1
635034	CLRND 5	161.0	560001	NODAWAYCO	161.0	1	153	145.7	146	4.8%	S1399 to Humboldt	XS541225>541164>\$1
635034	CLRND 5	161.0	560001	NODAWAYCO	161.0	1	153	145.7	146	4.8%	S1399 to Humboldt	XS541225>541162>\$1
635034	CLRND 5	161.0	560001	NODAWAYCO	161.0	1	153	145.7	146	4.8%	S1399 to Humboldt	XS631071>631074>\$1
635034	CLRND 5	161.0	560001	NODAWAYCO	161.0	1	153	145.8	146	3.8%	S1280 to Humboldt	XS635200>645451>\$1
635034	CLRND 5	161.0	560001	NODAWAYCO	161.0	1	153	145.8	146	3.8%	S1280 to Humboldt	XS635632>635633>\$1
635034	CLRND 5	161.0	560001	NODAWAYCO	161.0	1	153	145.8	146	3.8%	S1280 to Humboldt	XS300051>300054>\$1
635034	CLRND 5	161.0	560001	NODAWAYCO	161.0	1	153	145.7	146	3.8%	S1280 to Humboldt	XS300069>300031>\$10
635034	CLRND 5	161.0	560001	NODAWAYCO	161.0	1	153	145.7	146	3.8%	S1280 to Humboldt	XS300069>300032>\$11
635034	CLRND 5	161.0	560001	NODAWAYCO	161.0	1	153	145.7	146	3.8%	S1280 to Humboldt	XS300069>300020>\$21

635034	CLRNDA 5 161.0	560001	NODAWAYCO 161.0	1	153	145.7	146	3.8%	S1280 to Humboldt	XS300069>300021>\$22
635034	CLRNDA 5 161.0	560001	NODAWAYCO 161.0	1	153	145.7	146	3.8%	S1280 to Humboldt	XS531451>531429>531452\$1
635034	CLRNDA 5 161.0	560001	NODAWAYCO 161.0	1	153	145.8	146	3.8%	S1280 to Humboldt	XS533045>532734>\$1
635034	CLRNDA 5 161.0	560001	NODAWAYCO 161.0	1	153	145.8	146	3.8%	S1280 to Humboldt	XS533180>532671>\$1
635034	CLRNDA 5 161.0	560001	NODAWAYCO 161.0	1	153	145.7	146	3.8%	S1280 to Humboldt	CB928-BUS
635034	CLRNDA 5 161.0	560001	NODAWAYCO 161.0	1	153	145.7	146	3.8%	S1280 to Humboldt	LES1501
635034	CLRNDA 5 161.0	560001	NODAWAYCO 161.0	1	153	145.7	146	3.8%	S1280 to Humboldt	CB1345-BUS
635034	CLRNDA 5 161.0	560001	NODAWAYCO 161.0	1	153	145.7	146	3.8%	S1280 to Humboldt	CB3455-56&T1
635034	CLRNDA 5 161.0	560001	NODAWAYCO 161.0	1	153	145.7	146	3.8%	S1280 to Humboldt	161T37BK1OR2
635034	CLRNDA 5 161.0	560001	NODAWAYCO 161.0	1	153	145.8	146	3.8%	S975 (Humboldt) T4 161-69	XS635200>640226>\$1
635034	CLRNDA 5 161.0	560001	NODAWAYCO 161.0	1	153	145.8	146	3.8%	S975 (Humboldt) T4 161-69	XS532797>542981>\$1
635034	CLRNDA 5 161.0	560001	NODAWAYCO 161.0	1	153	145.8	146	3.8%	S975 (Humboldt) T4 161-69	XS542976>542963>\$1
635034	CLRNDA 5 161.0	560001	NODAWAYCO 161.0	1	153	145.7	146	3.8%	S975 (Humboldt) T4 161-69	CBWAG-T1-54
635034	CLRNDA 5 161.0	560001	NODAWAYCO 161.0	1	153	145.7	145.9	3.8%	S1280 to Humboldt	XS635200>640226>\$1
635034	CLRNDA 5 161.0	560001	NODAWAYCO 161.0	1	153	145.7	145.9	3.8%	S1280 to Humboldt	CB900BUS&979
635034	CLRNDA 5 161.0	560001	NODAWAYCO 161.0	1	153	145.7	145.9	3.8%	S1280 to Humboldt	CB1253-BUS
635034	CLRNDA 5 161.0	560001	NODAWAYCO 161.0	1	153	145.6	145.9	3.8%	S1280 to Humboldt	CBWAG-T1-54
635034	CLRNDA 5 161.0	560001	NODAWAYCO 161.0	1	153	145.7	145.9	3.8%	S975 (Humboldt) T4 161-69	CBWAG-T2-54
635034	CLRNDA 5 161.0	560001	NODAWAYCO 161.0	1	153	145.6	145.9	3.8%	S1280 to Humboldt	XS635005>635010>\$1
635034	CLRNDA 5 161.0	560001	NODAWAYCO 161.0	1	153	145.6	145.9	3.8%	S1280 to Humboldt	XS645454>645455>\$1
635034	CLRNDA 5 161.0	560001	NODAWAYCO 161.0	1	153	145.6	145.9	3.8%	S1280 to Humboldt	XS532913>532920>\$1
635034	CLRNDA 5 161.0	560001	NODAWAYCO 161.0	1	153	145.6	145.9	3.8%	S975 (Humboldt) T4 161-69	CBRAUN-FC-HO
635034	CLRNDA 5 161.0	560001	NODAWAYCO 161.0	1	153	145.5	145.8	4.8%	S1399 to Humboldt	XS631138>601029>\$1
635034	CLRNDA 5 161.0	560001	NODAWAYCO 161.0	1	153	145.5	145.8	4.8%	S1399 to Humboldt	XS532765>532766>\$1
635034	CLRNDA 5 161.0	560001	NODAWAYCO 161.0	1	153	145.4	145.8	4.8%	S1399 to Humboldt	CB917BUS1217
635034	CLRNDA 5 161.0	560001	NODAWAYCO 161.0	1	153	145.4	145.8	4.8%	S1399 to Humboldt	CB1217-BUS

635034	CLRNDA 5	161.0	560001	NODAWAYCO	161.0	1	153	145.5	145.8	3.8%	S1280 to Humboldt	MC1211-50-LS
635034	CLRNDA 5	161.0	560001	NODAWAYCO	161.0	1	153	145.5	145.8	3.8%	S1280 to Humboldt	XS300120>300001>\$1
635034	CLRNDA 5	161.0	560001	NODAWAYCO	161.0	1	153	145.5	145.8	3.8%	S1280 to Humboldt	CB1209-26&31
635034	CLRNDA 5	161.0	560001	NODAWAYCO	161.0	1	153	145.6	145.8	3.8%	S1280 to Humboldt	1252TARP
635034	CLRNDA 5	161.0	560001	NODAWAYCO	161.0	1	153	145.5	145.8	3.8%	S1280 to Humboldt	CBRAUN-FC-HO
635034	CLRNDA 5	161.0	560001	NODAWAYCO	161.0	1	153	145.6	145.8	3.8%	S1280 to Humboldt	CBWAG-T2-54
635034	CLRNDA 5	161.0	560001	NODAWAYCO	161.0	1	153	145.6	145.8	3.8%	S1280 to Humboldt	XS542965>542981>\$1
635034	CLRNDA 5	161.0	560001	NODAWAYCO	161.0	1	153	145.6	145.8	3.8%	S1280 to Humboldt S975 (Humboldt) T4 161-69	CB3454-55&WG
635034	CLRNDA 5	161.0	560001	NODAWAYCO	161.0	1	153	145.6	145.8	3.8%	S1280 to Humboldt	XS532768>532740>\$1
635034	CLRNDA 5	161.0	560001	NODAWAYCO	161.0	1	153	145.6	145.8	3.8%	S1280 to Humboldt	XS532768>532741>\$1
635034	CLRNDA 5	161.0	560001	NODAWAYCO	161.0	1	153	145.4	145.7	4.8%	S1399 to Humboldt	XS635680>635730>\$1
635034	CLRNDA 5	161.0	560001	NODAWAYCO	161.0	1	153	145.4	145.7	4.8%	S1399 to Humboldt	XS300091>560631>\$1
635034	CLRNDA 5	161.0	560001	NODAWAYCO	161.0	1	153	145.4	145.7	4.8%	S1399 to Humboldt	XS560631>560632>\$1
635034	CLRNDA 5	161.0	560001	NODAWAYCO	161.0	1	153	145.4	145.7	4.8%	S1399 to Humboldt	XS631071>631072>\$1
635034	CLRNDA 5	161.0	560001	NODAWAYCO	161.0	1	153	145.3	145.7	4.8%	S1399 to Humboldt	XS631070>631069>\$1
635034	CLRNDA 5	161.0	560001	NODAWAYCO	161.0	1	153	145.5	145.7	3.8%	S1280 to Humboldt	XS635010>635011>\$1
635034	CLRNDA 5	161.0	560001	NODAWAYCO	161.0	1	153	145.5	145.7	3.8%	S1280 to Humboldt	XS635641>635653>\$1
635034	CLRNDA 5	161.0	560001	NODAWAYCO	161.0	1	153	145.5	145.7	3.8%	S1280 to Humboldt	XS640424>640425>643170\$1
635034	CLRNDA 5	161.0	560001	NODAWAYCO	161.0	1	153	145.4	145.7	3.8%	S1280 to Humboldt	XS650185>645454>\$1
635034	CLRNDA 5	161.0	560001	NODAWAYCO	161.0	1	153	145.4	145.7	3.8%	S1280 to Humboldt	XS532768>532744>\$1
635034	CLRNDA 5	161.0	560001	NODAWAYCO	161.0	1	153	145.4	145.7	3.8%	S1280 to Humboldt	XS532768>532743>\$1
635034	CLRNDA 5	161.0	560001	NODAWAYCO	161.0	1	153	145.5	145.7	3.8%	S1280 to Humboldt	XS300120>300002>\$1
635034	CLRNDA 5	161.0	560001	NODAWAYCO	161.0	1	153	145.5	145.7	3.8%	S1280 to Humboldt	CB1227-BUS
635034	CLRNDA 5	161.0	560001	NODAWAYCO	161.0	1	153	145.4	145.7	3.8%	S1280 to Humboldt	CB3454-55&WG
635034	CLRNDA 5	161.0	560001	NODAWAYCO	161.0	1	153	145.4	145.7	3.8%	S1280 to Humboldt	CB3454-51&WG
635034	CLRNDA 5	161.0	560001	NODAWAYCO	161.0	1	153	145.4	145.7	3.8%	S1280 to Humboldt	BKR-WAG-3006
635034	CLRNDA 5	161.0	560001	NODAWAYCO	161.0	1	153	145.4	145.7	3.8%	S1280 to Humboldt	XS542995>542954>\$1

635034	CLRND 5	161.0	560001	NODAWAYCO	161.0	1	153	145.4	145.7	3.8%	S1280 to Humboldt	XS631069>652560>\$1
635034	CLRND 5	161.0	560001	NODAWAYCO	161.0	1	153	145.5	145.7	3.8%	S975 (Humboldt) T4 161-69	S938LINBUS
635034	CLRND 5	161.0	560001	NODAWAYCO	161.0	1	153	145.5	145.7	3.8%	S975 (Humboldt) T4 161-69	XS300041>300042>\$1
635034	CLRND 5	161.0	560001	NODAWAYCO	161.0	1	153	145.4	145.7	3.8%	S1280 to Humboldt	CBRAUN-LF-LH
635034	CLRND 5	161.0	560001	NODAWAYCO	161.0	1	153	145.3	145.6	4.8%	S1399 to Humboldt	XS531451>531465>\$1
635034	CLRND 5	161.0	560001	NODAWAYCO	161.0	1	153	145.4	145.6	3.8%	S1280 to Humboldt	XS300041>300042>\$1
635034	CLRND 5	161.0	560001	NODAWAYCO	161.0	1	153	145.4	145.6	3.8%	S1280 to Humboldt	XS532768>532742>\$1
635034	CLRND 5	161.0	560001	NODAWAYCO	161.0	1	153	145.4	145.6	3.8%	S1280 to Humboldt	CB1222-BUS
635034	CLRND 5	161.0	560001	NODAWAYCO	161.0	1	153	145.4	145.6	3.8%	S1280 to Humboldt	CB1256-49&53
635034	CLRND 5	161.0	560001	NODAWAYCO	161.0	1	153	145.4	145.6	3.8%	S975 (Humboldt) T4 161-69	MC1232-06-78
635034	CLRND 5	161.0	560001	NODAWAYCO	161.0	1	153	145.3	145.6	3.8%	S1280 to Humboldt	XS635001>635011>\$1
635034	CLRND 5	161.0	560001	NODAWAYCO	161.0	1	153	145.3	145.6	3.8%	S1280 to Humboldt	S938LINBUS
635034	CLRND 5	161.0	560001	NODAWAYCO	161.0	1	153	145.3	145.6	3.8%	S1280 to Humboldt	CB1229-BUS
635034	CLRND 5	161.0	560001	NODAWAYCO	161.0	1	153	145.3	145.6	3.8%	S1280 to Humboldt	XS542973>542967>\$1
635034	CLRND 5	161.0	560001	NODAWAYCO	161.0	1	153	145.2	145.5	3.8%	S1280 to Humboldt	XS645455>645456>\$1
635034	CLRND 5	161.0	560001	NODAWAYCO	161.0	1	153	145.3	145.5	3.8%	S1280 to Humboldt	MC1232-06-78
635034	CLRND 5	161.0	560001	NODAWAYCO	161.0	1	153	145.2	145.5	3.8%	S1280 to Humboldt	XS533180>532672>\$1
635034	CLRND 5	161.0	560001	NODAWAYCO	161.0	1	153	145.2	145.5	3.8%	S1280 to Humboldt	CB919-BUS
635034	CLRND 5	161.0	560001	NODAWAYCO	161.0	1	153	145.2	145.5	3.8%	S1280 to Humboldt	CB912-BUS
635034	CLRND 5	161.0	560001	NODAWAYCO	161.0	1	153	145.2	145.5	3.8%	S1280 to Humboldt	CB995-BUS938
635034	CLRND 5	161.0	560001	NODAWAYCO	161.0	1	153	145.2	145.5	3.8%	S1280 to Humboldt	XS541255>541170>\$1
635034	CLRND 5	161.0	560001	NODAWAYCO	161.0	1	153	145.3	145.5	3.8%	S1280 to Humboldt	XS533040>532721>\$1
635034	CLRND 5	161.0	560001	NODAWAYCO	161.0	1	153	145.3	145.5	3.8%	S1280 to Humboldt	XS533041>532725>\$1
635034	CLRND 5	161.0	560001	NODAWAYCO	161.0	1	153	145.3	145.5	3.8%	S1280 to Humboldt	CB923-BUSPXM
635034	CLRND 5	161.0	560001	NODAWAYCO	161.0	1	153	145.3	145.5	3.8%	S1280 to Humboldt	CB1286-BUS
635034	CLRND 5	161.0	560001	NODAWAYCO	161.0	1	153	145.3	145.5	3.8%	S1280 to Humboldt	XS533422>532694>\$1
635034	CLRND 5	161.0	560001	NODAWAYCO	161.0	1	153	145.3	145.5	3.8%	S1280 to Humboldt	XS533413>533422>\$1

635034	CLRND 5 161.0	560001	NODAWAYCO 161.0	1	153	145.3	145.5	3.8%	S975 (Humboldt) T4 161-69	XS542995>542952>\$1
635034	CLRND 5 161.0	560001	NODAWAYCO 161.0	1	153	145.3	145.5	3.8%	S975 (Humboldt) T4 161-69	XS542995>542953>\$1
635034	CLRND 5 161.0	560001	NODAWAYCO 161.0	1	153	145.2	145.4	3.8%	S1280 to Humboldt	CB1236-BUS
635034	CLRND 5 161.0	560001	NODAWAYCO 161.0	1	153	145.2	145.4	3.8%	S1280 to Humboldt	XS542995>542952>\$1
635034	CLRND 5 161.0	560001	NODAWAYCO 161.0	1	153	145.2	145.4	3.8%	S1280 to Humboldt	XS542995>542953>\$1
635034	CLRND 5 161.0	560001	NODAWAYCO 161.0	1	153	145.1	145.4	3.8%	S975 (Humboldt) T4 161-69	XS635037>635038>\$1
635034	CLRND 5 161.0	560001	NODAWAYCO 161.0	1	153	145	145.3	4.8%	S1399 to Humboldt	XS631070>631072>\$1
635034	CLRND 5 161.0	560001	NODAWAYCO 161.0	1	153	145.1	145.3	3.8%	S1280 to Humboldt	XS640227>640230>\$1
635034	CLRND 5 161.0	560001	NODAWAYCO 161.0	1	153	145	145.3	3.8%	S1280 to Humboldt	XS532765>532772>\$1
635034	CLRND 5 161.0	560001	NODAWAYCO 161.0	1	153	145.1	145.3	3.8%	S1280 to Humboldt	LES0805A
635034	CLRND 5 161.0	560001	NODAWAYCO 161.0	1	153	145.1	145.3	3.8%	S1280 to Humboldt	LES0805B
635034	CLRND 5 161.0	560001	NODAWAYCO 161.0	1	153	145.1	145.3	3.8%	S1280 to Humboldt	XS542973>542961>\$1
635034	CLRND 5 161.0	560001	NODAWAYCO 161.0	1	153	145.1	145.3	3.8%	S975 (Humboldt) T4 161-69	XS635001>635012>\$1
635034	CLRND 5 161.0	560001	NODAWAYCO 161.0	1	153	145	145.3	3.8%	S1280 to Humboldt	XS560620>560621>\$1
635034	CLRND 5 161.0	560001	NODAWAYCO 161.0	1	153	145	145.3	3.8%	S1280 to Humboldt	XS560621>560622>\$1
635034	CLRND 5 161.0	560001	NODAWAYCO 161.0	1	153	144.9	145.2	4.8%	S1399 to Humboldt	XS635730>636400>\$1
635034	CLRND 5 161.0	560001	NODAWAYCO 161.0	1	153	145	145.2	3.8%	S1280 to Humboldt	XS635001>635012>\$1
635034	CLRND 5 161.0	560001	NODAWAYCO 161.0	1	153	144.7	145.1	4.8%	S1399 to Humboldt	XS635000>635100>\$1
635034	CLRND 5 161.0	560001	NODAWAYCO 161.0	1	153	144.7	145.1	4.8%	S1399 to Humboldt	XS635100>635635>\$1
635034	CLRND 5 161.0	560001	NODAWAYCO 161.0	1	153	144.8	145.1	3.8%	Kelly to GEN2007-015	XS646399>648500>648501\$1
635034	CLRND 5 161.0	560001	NODAWAYCO 161.0	1	153	144.8	145.1	3.8%	S975 (Humboldt) T4 161-69	XS631071>631074>\$1
635034	CLRND 5 161.0	560001	NODAWAYCO 161.0	1	153	144.7	145	4.8%	S1399 to Humboldt	XS541199>541253>541371\$2
635034	CLRND 5 161.0	560001	NODAWAYCO 161.0	1	153	144.7	145	4.8%	S1399 to Humboldt	XS541199>541253>541370\$1
635034	CLRND 5 161.0	560001	NODAWAYCO 161.0	1	153	144.8	145	3.8%	S1280 to Humboldt	XS541225>541164>\$1
635034	CLRND 5 161.0	560001	NODAWAYCO 161.0	1	153	144.8	145	3.8%	S1280 to Humboldt	XS541225>541163>\$1
635034	CLRND 5 161.0	560001	NODAWAYCO 161.0	1	153	144.8	145	3.8%	S1280 to Humboldt	XS541225>541162>\$1

635034	CLRND 5	161.0	560001	NODAWAYCO	161.0	1	153	144.8	145	3.8%	S1280 to Humboldt	XS542968>542981>\$1
635034	CLRND 5	161.0	560001	NODAWAYCO	161.0	1	153	144.6	144.9	4.8%	S1399 to Humboldt	XS541199>542982>\$1
635034	CLRND 5	161.0	560001	NODAWAYCO	161.0	1	153	144.7	144.9	3.8%	Kelly to GEN2007-015	CBHUM-80&T4
635034	CLRND 5	161.0	560001	NODAWAYCO	161.0	1	153	144.7	144.9	3.8%	S975 (Humboldt) T4 161-69	CB917BUS1217
635034	CLRND 5	161.0	560001	NODAWAYCO	161.0	1	153	144.7	144.9	3.8%	S975 (Humboldt) T4 161-69	CB1217-BUS
635034	CLRND 5	161.0	560001	NODAWAYCO	161.0	1	153	144.5	144.8	4.8%	S1399 to Humboldt	XS635000>635600>\$1
635034	CLRND 5	161.0	560001	NODAWAYCO	161.0	1	153	144.5	144.8	4.8%	S1399 to Humboldt	XS533040>532722>\$1
635034	CLRND 5	161.0	560001	NODAWAYCO	161.0	1	153	144.6	144.8	3.8%	S1280 to Humboldt	XS532765>532766>\$1
635034	CLRND 5	161.0	560001	NODAWAYCO	161.0	1	153	144.5	144.8	3.8%	S1280 to Humboldt	CB1217-BUS
635034	CLRND 5	161.0	560001	NODAWAYCO	161.0	1	153	144.5	144.8	3.8%	S1280 to Humboldt	CB917BUS1217
635034	CLRND 5	161.0	560001	NODAWAYCO	161.0	1	153	144.6	144.8	3.8%	S975 (Humboldt) T4 161-69	XS300091>560631>\$1
635034	CLRND 5	161.0	560001	NODAWAYCO	161.0	1	153	144.6	144.8	3.8%	S975 (Humboldt) T4 161-69	XS560631>560632>\$1
635034	CLRND 5	161.0	560001	NODAWAYCO	161.0	1	153	144.4	144.7	3.8%	S1280 to Humboldt	XS635680>635730>\$1
635034	CLRND 5	161.0	560001	NODAWAYCO	161.0	1	153	144.5	144.7	3.8%	S1280 to Humboldt	XS631071>631072>\$1
635034	CLRND 5	161.0	560001	NODAWAYCO	161.0	1	153	144.4	144.6	3.8%	S1280 to Humboldt	XS531451>531465>\$1
635034	CLRND 5	161.0	560001	NODAWAYCO	161.0	1	153	144.3	144.5	3.8%	Kelly to GEN2007-015	XS580070>648500>\$1
635034	CLRND 5	161.0	560001	NODAWAYCO	161.0	1	153	144.3	144.5	3.8%	Kelly to GEN2007-015	XS580070>580071>\$1
635034	CLRND 5	161.0	560001	NODAWAYCO	161.0	1	153	144	144.4	4.8%	S1399 to Humboldt	XS300049>300003>\$1
635034	CLRND 5	161.0	560001	NODAWAYCO	161.0	1	153	144	144.3	4.8%	S1399 to Humboldt	XS532854>532663>\$1
635034	CLRND 5	161.0	560001	NODAWAYCO	161.0	1	153	144	144.3	4.8%	S1399 to Humboldt	XS532853>532854>\$1
635034	CLRND 5	161.0	560001	NODAWAYCO	161.0	1	153	144.1	144.3	3.8%	S1280 to Humboldt	XS631070>631072>\$1
635034	CLRND 5	161.0	560001	NODAWAYCO	161.0	1	153	143.9	144.2	4.8%	S1399 to Humboldt	XS631078>635641>\$1
635034	CLRND 5	161.0	560001	NODAWAYCO	161.0	1	153	143.9	144.2	3.8%	S1280 to Humboldt	XS635730>636400>\$1
635034	CLRND 5	161.0	560001	NODAWAYCO	161.0	1	153	143.7	144.1	4.8%	S1399 to Humboldt	XS640183>640325>\$1
635034	CLRND 5	161.0	560001	NODAWAYCO	161.0	1	153	143.8	144.1	3.8%	S1280 to Humboldt	XS635000>635100>\$1
635034	CLRND 5	161.0	560001	NODAWAYCO	161.0	1	153	143.8	144.1	3.8%	S1280 to Humboldt	XS635100>635635>\$1

635034	CLRND 5	161.0	560001	NODAWAYCO	161.0	1	153	143.7	144	3.8%	S1280 to Humboldt	XS541199>541253>541371\$2
635034	CLRND 5	161.0	560001	NODAWAYCO	161.0	1	153	143.7	144	3.8%	S1280 to Humboldt	XS541199>541253>541370\$1
635034	CLRND 5	161.0	560001	NODAWAYCO	161.0	1	153	143.6	143.9	3.8%	S1280 to Humboldt	XS533040>532722>\$1
635034	CLRND 5	161.0	560001	NODAWAYCO	161.0	1	153	143.6	143.8	3.8%	S1280 to Humboldt	XS541199>542982>\$1
635034	CLRND 5	161.0	560001	NODAWAYCO	161.0	1	153	143.5	143.8	3.8%	S1280 to Humboldt	XS635000>635600>\$1
635034	CLRND 5	161.0	560001	NODAWAYCO	161.0	1	153	143.1	143.4	3.8%	S1280 to Humboldt	XS300049>300003>\$1
635034	CLRND 5	161.0	560001	NODAWAYCO	161.0	1	153	143.2	143.4	3.8%	S1280 to Humboldt	XS532854>532663>\$1
635034	CLRND 5	161.0	560001	NODAWAYCO	161.0	1	153	143.2	143.4	3.8%	S1280 to Humboldt	XS532853>532854>\$1
635034	CLRND 5	161.0	560001	NODAWAYCO	161.0	1	153	143	143.3	4.8%	S1399 to Humboldt	XS541250>541151>\$1
635034	CLRND 5	161.0	560001	NODAWAYCO	161.0	1	153	143.1	143.3	3.8%	S975 (Humboldt) T4 161-69	XS631078>635641>\$1
635034	CLRND 5	161.0	560001	NODAWAYCO	161.0	1	153	142.9	143.2	4.8%	S1399 to Humboldt	XS300039>300076>\$3
635034	CLRND 5	161.0	560001	NODAWAYCO	161.0	1	153	142.1	142.4	4.8%	S1399 to Humboldt	XS300107>560643>\$1
635034	CLRND 5	161.0	560001	NODAWAYCO	161.0	1	153	142.1	142.4	4.8%	S1399 to Humboldt	XS560643>560644>\$1
635034	CLRND 5	161.0	560001	NODAWAYCO	161.0	1	153	142.1	142.4	3.8%	S1280 to Humboldt	XS541250>541151>\$1
635034	CLRND 5	161.0	560001	NODAWAYCO	161.0	1	153	141.9	142.2	4.8%	S1399 to Humboldt	XS635000>645456>\$1
635034	CLRND 5	161.0	560001	NODAWAYCO	161.0	1	153	141.8	142.1	3.8%	S1280 to Humboldt	XS300039>300076>\$3
635034	CLRND 5	161.0	560001	NODAWAYCO	161.0	1	153	141.7	142	4.8%	S1399 to Humboldt	CB3456-55&CB
635034	CLRND 5	161.0	560001	NODAWAYCO	161.0	1	153	141.3	141.5	3.8%	S975 (Humboldt) T4 161-69	XS300107>560643>\$1
635034	CLRND 5	161.0	560001	NODAWAYCO	161.0	1	153	141.3	141.5	3.8%	S975 (Humboldt) T4 161-69	XS560643>560644>\$1
635034	CLRND 5	161.0	560001	NODAWAYCO	161.0	1	153	140.9	141.3	3.8%	S1399 to Humboldt	XS631078>652560>\$1
635034	CLRND 5	161.0	560001	NODAWAYCO	161.0	1	153	140.9	141.2	4.8%	S1399 to Humboldt	XS531451>640325>\$1
635034	CLRND 5	161.0	560001	NODAWAYCO	161.0	1	153	141	141.2	3.8%	S1280 to Humboldt	XS635000>645456>\$1
635034	CLRND 5	161.0	560001	NODAWAYCO	161.0	1	153	140.8	141.1	4.8%	S1399 to Humboldt	XS542981>542956>\$1
635034	CLRND 5	161.0	560001	NODAWAYCO	161.0	1	153	140.6	141	4.8%	S1399 to Humboldt	XS532852>532651>\$1
635034	CLRND 5	161.0	560001	NODAWAYCO	161.0	1	153	140.7	141	3.8%	S1280 to Humboldt	CB3456-55&CB
635034	CLRND 5	161.0	560001	NODAWAYCO	161.0	1	153	140.5	140.8	3.8%	S1399 to Humboldt	XS532766>532653>\$1
635034	CLRND 5	161.0	560001	NODAWAYCO	161.0	1	153	140.5	140.8	3.8%	S1399 to Humboldt	XS532766>532652>\$1

635034	CLRND 5 161.0	560001	NODAWAYCO 161.0	1	153	140.3	140.6	4.8%	S1399 to Humboldt	XS542973>542951>\$1
635034	CLRND 5 161.0	560001	NODAWAYCO 161.0	1	153	140.2	140.6	4.8%	S1399 to Humboldt	XS542981>542955>\$1
635034	CLRND 5 161.0	560001	NODAWAYCO 161.0	1	153	140.4	140.6	3.8%	S975 (Humboldt) T4 161-69	XS531451>640325>\$1
635034	CLRND 5 161.0	560001	NODAWAYCO 161.0	1	153	140.1	140.4	3.8%	S1280 to Humboldt	XS531451>640325>\$1
635034	CLRND 5 161.0	560001	NODAWAYCO 161.0	1	153	140.1	140.4	3.8%	S975 (Humboldt) T4 161-69	XS631078>652560>\$1
635034	CLRND 5 161.0	560001	NODAWAYCO 161.0	1	153	140	140.2	3.8%	S1280 to Humboldt	XS542981>542956>\$1
635034	CLRND 5 161.0	560001	NODAWAYCO 161.0	1	153	139.5	139.7	3.8%	S1280 to Humboldt	XS542981>542955>\$1
635034	CLRND 5 161.0	560001	NODAWAYCO 161.0	1	153	138.3	138.7	5.7%	S1399 to Humboldt	XS541199>640139>\$1
635034	CLRND 5 161.0	560001	NODAWAYCO 161.0	1	153	138	138.3	4.8%	S1399 to Humboldt	XS542982>542957>\$1
635034	CLRND 5 161.0	560001	NODAWAYCO 161.0	1	153	137.2	137.6	5.7%	S1399 to Humboldt	XS300039>560620>\$1
635034	CLRND 5 161.0	560001	NODAWAYCO 161.0	1	153	137	137.3	3.8%	S1280 to Humboldt	XS541199>640139>\$1
635034	CLRND 5 161.0	560001	NODAWAYCO 161.0	1	153	136.8	137.1	4.8%	S1399 to Humboldt	XS532797>532751>\$1
635034	CLRND 5 161.0	560001	NODAWAYCO 161.0	1	153	136.3	136.5	3.8%	S975 (Humboldt) T4 161-69	XS300039>560620>\$1
635034	CLRND 5 161.0	560001	NODAWAYCO 161.0	1	153	136.2	136.4	3.8%	S1280 to Humboldt	XS532797>532751>\$1
635034	CLRND 5 161.0	560001	NODAWAYCO 161.0	1	153	136	136.4	3.8%	S1399 to Humboldt	XS542982>542962>\$1
635034	CLRND 5 161.0	560001	NODAWAYCO 161.0	1	153	136	136.3	4.8%	S1280 to Humboldt	XS300039>560620>\$1
635034	CLRND 5 161.0	560001	NODAWAYCO 161.0	1	153	135.2	135.5	3.8%	S1280 to Humboldt	XS542982>542962>\$1
635034	CLRND 5 161.0	560001	NODAWAYCO 161.0	1	153	132.4	132.7	3.8%	S1399 to Humboldt	XS560001>560614>\$1
635034	CLRND 5 161.0	560001	NODAWAYCO 161.0	1	153	132.4	132.7	3.8%	S1399 to Humboldt	XS560614>560615>\$1
635034	CLRND 5 161.0	560001	NODAWAYCO 161.0	1	153	131.5	131.7	3.8%	S1280 to Humboldt	XS560001>560614>\$1
635034	CLRND 5 161.0	560001	NODAWAYCO 161.0	1	153	131.4	131.7	3.8%	S1280 to Humboldt	XS560614>560615>\$1
635034	CLRND 5 161.0	560001	NODAWAYCO 161.0	1	153	131	131.4	4.8%	S1399 to Humboldt	XS560617>560618>\$1
635034	CLRND 5 161.0	560001	NODAWAYCO 161.0	1	153	131.1	131.4	4.8%	S1399 to Humboldt	XS560001>560617>\$1
635034	CLRND 5 161.0	560001	NODAWAYCO 161.0	1	153	130.1	130.3	3.8%	S1280 to Humboldt	XS560617>560618>\$1
635034	CLRND 5 161.0	560001	NODAWAYCO 161.0	1	153	130.1	130.3	3.8%	S1280 to Humboldt	XS560001>560617>\$1
635034	CLRND 5 161.0	560001	NODAWAYCO 161.0	1	153	116.9	117.3	4.8%	S1399 to Humboldt	XS635038>652560>\$1
635034	CLRND 5 161.0	560001	NODAWAYCO 161.0	1	153	116	116.3	3.8%	S1280 to Humboldt	XS635038>652560>\$1

635034	CLRNDA 5 161.0	560001	NODAWAYCO 161.0	1	153	113.9	114.2	4.8%	S1399 to Humboldt	XS635034>635038>\$1
635034	CLRNDA 5 161.0	560001	NODAWAYCO 161.0	1	153	112.9	113.2	3.8%	S1280 to Humboldt	XS635034>635038>\$1
635034	CLRNDA 5 161.0	560001	NODAWAYCO 161.0	1	153	105	105.3	4.8%	S1399 to Humboldt	XS560001>560550>\$1
635034	CLRNDA 5 161.0	560001	NODAWAYCO 161.0	1	153	104	104.2	3.8%	S1280 to Humboldt	XS560001>560550>\$1
635034	CLRNDA 5 161.0	560001	NODAWAYCO 161.0	1	153	103.2	103.5	4.8%	S1399 to Humboldt	XS560001>560553>\$1
635034	CLRNDA 5 161.0	560001	NODAWAYCO 161.0	1	153	102.2	102.5	3.8%	S1280 to Humboldt	XS560001>560553>\$1
560332	G10-47T 115.0	640208	HARBINE7 115.0	1	99	129.5	130.3	6.7%	Kelly to GEN2007-015	CBHUM-80&T4
560332	G10-47T 115.0	640208	HARBINE7 115.0	1	99	125	125.4	3.8%	Kelly to GEN2007-015	XS640088>640278>\$1
560332	G10-47T 115.0	640208	HARBINE7 115.0	1	99	116.9	117.3	3.8%	Kelly to GEN2007-015	LN-CLATONIA
560332	G10-47T 115.0	640208	HARBINE7 115.0	1	99	115.3	116.3	8.6%	S1280 to Humboldt	XS532913>560610>\$1
560332	G10-47T 115.0	640208	HARBINE7 115.0	1	99	115.9	116.3	3.8%	Kelly to GEN2007-015	XS640111>640278>\$1
560332	G10-47T 115.0	640208	HARBINE7 115.0	1	99	115.1	116.1	9.5%	Kelly to GEN2007-015	XS640234>646280>\$1
560332	G10-47T 115.0	640208	HARBINE7 115.0	1	99	112.8	113.9	9.5%	Kelly to GEN2007-015	CB1280-BUS
560332	G10-47T 115.0	640208	HARBINE7 115.0	1	99	107.2	107.6	3.8%	S1280 to Humboldt	XS533332>560141>\$1
560332	G10-47T 115.0	640208	HARBINE7 115.0	1	99	105.8	106.1	3.8%	S975 (Humboldt) T4 161-69	XS533332>560141>\$1
560332	G10-47T 115.0	640208	HARBINE7 115.0	1	99	104.7	105	3.8%	Kelly to GEN2007-015	XS640277>640278>640280\$1
560332	G10-47T 115.0	640208	HARBINE7 115.0	1	99	103.5	104	4.8%	S975 (Humboldt) T4 161-69	XS532913>560610>\$1
560332	G10-47T 115.0	640208	HARBINE7 115.0	1	99	102.6	103.1	3.8%	Kelly to GEN2007-015	CB1206-44SC3
560332	G10-47T 115.0	640208	HARBINE7 115.0	1	99	101.8	102.2	4.8%	Kelly to GEN2007-015	XS645033>646206>\$1
560332	G10-47T 115.0	640208	HARBINE7 115.0	1	99	101.8	102.2	4.8%	Kelly to GEN2007-015	SARPY3_GEN
560332	G10-47T 115.0	640208	HARBINE7 115.0	1	99	101.6	102.1	3.8%	Kelly to GEN2007-015	CB1206-T2SC3
560332	G10-47T 115.0	640208	HARBINE7 115.0	1	99	101.3	101.9	5.7%	Kelly to GEN2007-015	XS640140>646280>\$1
640234	HUMBOLTS 161.0	3WNDTR	HUMBOLDT T2 WND	1	126	151.4	159.2	94.3%	Kelly to GEN2007-015	CBHUM-80&T4
640234	HUMBOLTS 161.0	3WNDTR	S975 T4 WND	1	67.2	162.3	168	37.1%	Kelly to GEN2007-015	CB1280-BUS
640234	HUMBOLTS 161.0	3WNDTR	S975 T4 WND	1	67.2	150.3	156.5	40.0%	Kelly to GEN2007-015	XS640234>646280>\$1
640234	HUMBOLTS 161.0	3WNDTR	S975 T4 WND	1	67.2	149.2	155.4	40.0%	S1280 to Humboldt	XS532913>560610>\$1

640234	HUMBOLTS 161.0	3WNDTR	S975 T4 WND	1	67.2	131	131.9	5.7%	Kelly to GEN2007-015	CB1263-BUS
640234	HUMBOLTS 161.0	3WNDTR	S975 T4 WND	1	67.2	123.2	124.7	9.5%	Kelly to GEN2007-015	XS646263>646280>\$1
640234	HUMBOLTS 161.0	3WNDTR	S975 T4 WND	1	67.2	123.6	124.3	4.8%	Kelly to GEN2007-015	XS646263>647111>648263\$1
640234	HUMBOLTS 161.0	3WNDTR	S975 T4 WND	1	67.2	121.4	122	3.8%	Kelly to GEN2007-015	S1263T1 AUTO
640234	HUMBOLTS 161.0	3WNDTR	S975 T4 WND	1	67.2	116.7	117.3	3.8%	Kelly to GEN2007-015	XS647111>647963>\$1
640234	HUMBOLTS 161.0	3WNDTR	S975 T4 WND	1	67.2	105.9	107.3	8.6%	S1280 to Humboldt	S1263T1 AUTO
640234	HUMBOLTS 161.0	3WNDTR	S975 T4 WND	1	67.2	105.2	106.8	10.5%	S1280 to Humboldt	CB1263-BUS
640234	HUMBOLTS 161.0	3WNDTR	S975 T4 WND	1	67.2	104.5	106.2	10.5%	S1280 to Humboldt	XS646263>647111>648263\$1
640234	HUMBOLTS 161.0	3WNDTR	S975 T4 WND	1	67.2	103.3	104.6	8.6%	S1280 to Humboldt	XS647111>647963>\$1
640235	HUMBOLT7 115.0	3WNDTR	HUMBOLDT T2 WND	1	126	152.4	160.2	94.3%	Kelly to GEN2007-015	CBHUM-80&T4
640235	HUMBOLT7 115.0	640361	STEINER7 115.0	1	120	155.4	166	93.3%	Kelly to GEN2007-015	CBHUM-80&T4
533217	KELLY 3 115.0	3WNDTR	KELLY 1X WND	1	168	114.6	120.8	99.0%	S1399 to Humboldt	XS532913>532920>\$1
533217	KELLY 3 115.0	533331	KING HL3 115.0	1	92	115.9	123.4	60.0%	S1399 to Humboldt	XS532913>532920>\$1
532913	KELLY 5 161.0	3WNDTR	KELLY 1X WND	1	168	114.3	120.4	97.1%	S1399 to Humboldt	XS532913>532920>\$1
532913	KELLY 5 161.0	532920	TECHILL5 161.0	1	161	119.6	127	96.2%	S1399 to Humboldt	XS532913>533217>532942\$1
533332	KNOB HL3 115.0	560141	G09-40T 115.0	1	92	110.5	115.2	38.1%	S1399 to Humboldt	XS532913>532920>\$1
646263	S1263 5 161.0	3WNDTR	S1263 T1 WND	1	106	108.1	108.5	3.8%	Kelly to GEN2007-015	XS640234>647975>648275\$1
646263	S1263 5 161.0	3WNDTR	S1263 T1 WND	1	106	106.1	106.5	3.8%	Kelly to GEN2007-015	CB975-T4-965
646263	S1263 5 161.0	3WNDTR	S1263 T1 WND	1	106	101.6	101.9	3.8%	S975 (Humboldt) T4 161-69	XS640234>640235>643087\$1
646263	S1263 5 161.0	3WNDTR	S1263 T1 WND	1	106	101.1	101.6	5.7%	S975 (Humboldt) T4 161-69	XS646399>560610>\$1
646263	S1263 5 161.0	3WNDTR	S1263 T1 WND	1	106	101.2	101.5	3.8%	S975 (Humboldt) T4 161-69	XS640235>640361>\$1
646263	S1263 5 161.0	3WNDTR	S1263 T1 WND	1	106	101.1	101.5	3.8%	S975 (Humboldt) T4 161-69	LN-1176
646263	S1263 5 161.0	3WNDTR	S1263 T1 WND	1	106	101.1	101.4	3.8%	S975 (Humboldt) T4 161-69	XS640076>640361>\$1
647975	S975 8 69.00	3WNDTR	S975 T4 WND	1	67.2	158.7	164.1	35.2%	Kelly to GEN2007-015	CB1280-BUS
647975	S975 8 69.00	3WNDTR	S975 T4 WND	1	67.2	148.6	154.7	39.0%	Kelly to GEN2007-015	XS640234>646280>\$1

647975	S975 8 69.00	3WNDTR	S975 T4 WND	1	67.2	147.5	153.6	39.0%	S1280 to Humboldt	XS532913>560610>\$1
647975	S975 8 69.00	3WNDTR	S975 T4 WND	1	67.2	126.7	127.5	5.7%	Kelly to GEN2007-015	CB1263-BUS
647975	S975 8 69.00	3WNDTR	S975 T4 WND	1	67.2	120.7	122.2	9.5%	Kelly to GEN2007-015	XS646263>646280>\$1
647975	S975 8 69.00	3WNDTR	S975 T4 WND	1	67.2	119.7	120.4	4.8%	Kelly to GEN2007-015	XS646263>647111>648263\$1
647975	S975 8 69.00	3WNDTR	S975 T4 WND	1	67.2	117.1	117.7	3.8%	Kelly to GEN2007-015	S1263T1 AUTO
647975	S975 8 69.00	3WNDTR	S975 T4 WND	1	67.2	102.2	103.8	10.5%	S1280 to Humboldt	CB1263-BUS
647975	S975 8 69.00	3WNDTR	S975 T4 WND	1	67.2	102.5	103.8	8.6%	S1280 to Humboldt	S1263T1 AUTO
647975	S975 8 69.00	3WNDTR	S975 T4 WND	1	67.2	101.6	103.2	9.5%	S1280 to Humboldt	XS646263>647111>648263\$1
647975	S975 8 69.00	3WNDTR	S975 T4 WND	1	67.2	100.1	101.4	8.6%	S1280 to Humboldt	XS647111>647963>\$1
647111	W BROCK8 69.00	3WNDTR	S1263 T1 WND	1	106	105.9	106.4	3.8%	Kelly to GEN2007-015	XS640234>647975>648275\$1
647111	W BROCK8 69.00	3WNDTR	S1263 T1 WND	1	106	104	104.4	4.8%	Kelly to GEN2007-015	CB975-T4-965

Appendix D. Full Substation Fault Current (kA) Comparison

Table D-1: 2 – Cycle Breaker

AECI			Fault Current (kA) without GEN-2010-041		Fault Current (kA) with GEN-2010-041		Fault Current Increase (kA) with GEN-2010-041	
Rated Interrupting Time			2-cycles		2-cycles		2-cycles	
Contact Parting Time			1.5-Cycles		1.5-Cycles		1.5-Cycles	
BUS			Total ¹	Symm ²	Total ¹	Symm ²	Total ¹	Symm ²
34913	MINTWD	345.00	19.487	15.576	19.488	15.576	0.001	0.000
34914	MINTWDG	34.500	196.863	159.864	196.864	159.865	0.001	0.001
96039	7FAIRPT	345.00	15.037	12.842	15.037	12.842	0.000	0.000
WERE			Fault Current (kA) without GEN-2010-041		Fault Current (kA) with GEN-2010-041		Fault Current Increase (kA) with GEN-2010-041	
Rated Interrupting Time			2-cycles		2-cycles		2-cycles	
Contact Parting Time			1.5-Cycles		1.5-Cycles		1.5-Cycles	
BUS			Total ¹	Symm ²	Total ¹	Symm ²	Total ¹	Symm ²
54016	2007-15T	161.00	8.230	7.411	8.339	7.474	0.109	0.063
56654	CLR_1	0.5750	469.224	422.136	469.422	422.283	0.198	0.147
56655	CLR_2	0.5750	450.382	406.253	450.549	406.382	0.167	0.129
56656	CLR_3	0.5750	450.178	406.648	450.344	406.778	0.166	0.130
56657	CLR_4	0.5750	426.720	385.448	426.856	385.558	0.136	0.110
56658	CLR_5	0.5750	471.801	428.838	471.993	428.991	0.192	0.153
56659	MAIN XFMR	LS34.500	25.610	21.352	25.737	21.388	0.127	0.036
56660	2007-D	13.800	43.313	34.201	43.629	34.279	0.316	0.078
56661	LEC U3	14.400	65.828	51.105	65.828	51.105	0.000	0.000
56664	WTG EQ 1	34.500	11.065	10.734	11.073	10.742	0.008	0.008
56665	WTG EQ 2	34.500	9.302	9.012	9.307	9.017	0.005	0.005
56666	WTG EQ 3	34.500	9.324	9.040	9.330	9.045	0.006	0.005
56667	WTG EQ 4	34.500	7.978	7.697	7.984	7.701	0.006	0.004
56668	WTG EQ 5	34.500	11.065	10.767	11.073	10.775	0.008	0.008
56671	TEC U7	14.400	151.477	117.798	151.478	117.799	0.001	0.001
56672	TEC U8	16.000	104.716	81.335	104.717	81.336	0.001	0.001
56774	SWISVAL7	345.00	15.272	12.714	15.272	12.714	0.000	0.000
56815	SWISVAL1	14.400	52.473	40.910	52.473	40.911	0.000	0.001
56851	AUBURN 6	230.00	14.484	13.076	14.484	13.076	0.000	0.000
56853	LAWHILL6	230.00	21.898	17.010	21.898	17.010	0.000	0.000
56855	MIDLAND6	230.00	17.344	13.494	17.344	13.494	0.000	0.000

56856	SWISVAL6	230.00	21.578	17.934	21.579	17.934	0.001	0.000
56857	TECHILL6	230.00	14.264	11.108	14.264	11.109	0.000	0.001
56863	MORRIS 6	230.00	15.776	12.281	15.776	12.281	0.000	0.000
56884	MIDLAND1	18.000	61.115	47.485	61.115	47.485	0.000	0.000
56886	TECHILL1	13.800	91.905	71.373	91.909	71.376	0.004	0.004
56913	KELLY 5	161.00	7.073	6.633	7.116	6.660	0.043	0.027
56920	TECHILL5	161.00	9.377	7.305	9.381	7.308	0.004	0.003
56921	WM BROS5	161.00	4.672	4.438	4.673	4.439	0.001	0.001
56936	MIDIAN 5	161.00	5.661	4.431	5.662	4.431	0.001	0.000
56942	KELLY 1	13.800	6.352	4.933	6.357	4.936	0.005	0.003
56956	MIDIAN 1	12.470	9.010	6.995	9.010	6.995	0.000	0.000
56986	BENTON 4	138.00	32.397	25.244	32.397	25.244	0.000	0.000
56987	BUTLER 4	138.00	11.884	10.964	11.884	10.964	0.000	0.000
56990	MIDIAN 4	138.00	12.271	11.228	12.271	11.228	0.000	0.000
57082	MIDIAN 1	13.200	24.201	20.775	24.201	20.775	0.000	0.000
57152	CIRCLVL3	115.00	6.409	6.251	6.412	6.254	0.003	0.003
57153	COLINE 3	115.00	25.308	23.166	25.310	23.168	0.002	0.002
57156	54&MERI3	115.00	19.052	17.171	19.053	17.172	0.001	0.001
57158	4CORNER3	115.00	6.240	6.114	6.240	6.114	0.000	0.000
57160	41CALIF3	115.00	19.338	18.586	19.339	18.587	0.001	0.001
57162	GOODYR 3	115.00	20.545	18.914	20.547	18.916	0.002	0.002
57163	HOYT 3	115.00	31.156	24.191	31.160	24.194	0.004	0.003
57164	HTI 3	115.00	14.781	13.898	14.782	13.900	0.001	0.002
57165	HTI JCT3	115.00	20.230	16.934	20.233	16.936	0.003	0.002
57166	INDIANH3	115.00	18.764	17.261	18.765	17.262	0.001	0.001
57168	N TYLER3	115.00	18.356	16.933	18.357	16.934	0.001	0.001
57169	NTHLAND3	115.00	16.494	14.961	16.495	14.962	0.001	0.001
57172	QUINTON3	115.00	19.716	18.223	19.718	18.224	0.002	0.001
57173	SCRANTN3	115.00	5.711	5.592	5.711	5.592	0.000	0.000
57176	SHAWNEE3	115.00	12.603	12.287	12.604	12.287	0.001	0.000
57177	6 GOLDN3	115.00	18.088	16.487	18.089	16.488	0.001	0.001
57180	TEC E 3	115.00	39.065	31.381	39.068	31.384	0.003	0.003
57182	TECHILE3	115.00	40.986	32.291	40.990	32.294	0.004	0.003
57184	12&CLAY3	115.00	18.622	17.271	18.623	17.272	0.001	0.001
57186	29 GAGE3	115.00	19.633	18.305	19.634	18.306	0.001	0.001
57187	27CROCO3	115.00	22.316	21.379	22.318	21.380	0.002	0.001
57188	27CROCJ3	115.00	21.904	20.976	21.906	20.978	0.002	0.002
57192	HOOKJCT3	115.00	26.638	23.529	26.640	23.531	0.002	0.002
57212	BROWNCO3	115.00	2.723	2.630	2.725	2.632	0.002	0.002
57217	KELLY 3	115.00	8.665	7.996	8.707	8.017	0.042	0.021

57219	TONGATP3	115.00	15.096	13.077	15.096	13.077	0.000	0.000
57234	BISMARCK3	115.00	18.704	17.094	18.705	17.094	0.001	0.000
57236	COOP 3	115.00	17.733	16.546	17.733	16.547	0.000	0.001
57237	CRAIG J3	115.00	13.447	12.234	13.447	12.234	0.000	0.000
57241	FMC 3	115.00	17.952	16.276	17.952	16.276	0.000	0.000
57243	JAGGARD3	115.00	11.224	10.864	11.224	10.864	0.000	0.000
57244	JARBALO3	115.00	20.178	17.462	20.178	17.462	0.000	0.000
57248	LEC U3 3	115.00	33.465	25.978	33.465	25.979	0.000	0.001
57250	LWRNCHL3	115.00	41.008	31.835	41.008	31.835	0.000	0.000
57252	MIDLAND3	115.00	32.884	25.646	32.884	25.646	0.000	0.000
57253	MOCKBRD3	115.00	18.675	17.191	18.676	17.191	0.001	0.000
57261	PENTAGN3	115.00	15.410	14.020	15.410	14.020	0.000	0.000
57269	STULL 3	115.00	13.020	12.662	13.021	12.663	0.001	0.001
57270	STULL T3	115.00	13.149	12.785	13.149	12.785	0.000	0.000
57271	SWLWRNC3	115.00	20.070	17.974	20.071	17.974	0.001	0.000
57282	MUND 3	115.00	14.019	12.428	14.019	12.429	0.000	0.001
57322	BAILEYV3	115.00	4.887	4.700	4.892	4.705	0.005	0.005
57331	KING HL3	115.00	6.164	5.985	6.172	5.993	0.008	0.008
57332	KNOB HL3	115.00	4.963	4.763	4.965	4.764	0.002	0.001
57337	SENECA 3	115.00	5.736	5.360	5.751	5.367	0.015	0.007
57338	SMITTYV3	115.00	4.473	4.329	4.476	4.332	0.003	0.003
57443	COLINE 1	34.500	5.295	4.113	5.295	4.113	0.000	0.000
57448	TEC 1	13.800	16.678	13.000	16.678	13.001	0.000	0.001
57452	LEC 1	34.500	2.628	2.040	2.628	2.040	0.000	0.000
57456	COLINE 2	69.000	11.849	9.982	11.849	9.982	0.000	0.000
57457	DEERCRK2	69.000	12.299	11.041	12.299	11.041	0.000	0.000
57458	ROCKCRK2	69.000	4.235	4.145	4.235	4.145	0.000	0.000
57460	SANTAFJ2	69.000	13.595	11.777	13.595	11.777	0.000	0.000
57462	TEC 2	69.000	21.001	16.324	21.001	16.325	0.000	0.001
57463	TEC GT 2	69.000	19.522	15.204	19.523	15.204	0.001	0.000
57482	VALLEY12	69.000	3.484	3.417	3.484	3.417	0.000	0.000
57496	LEC 2	69.000	5.850	4.543	5.850	4.543	0.000	0.000
57597	MIDIAN 2	69.000	15.829	13.974	15.829	13.974	0.000	0.000
57884	UCB 1	13.800	32.133	24.955	32.133	24.955	0.000	0.000
MIPU			Fault Current (kA) without GEN-2010-041		Fault Current (kA) with GEN-2010-041		Fault Current Increase (kA) with GEN-2010-041	
Rated Interrupting Time			2-cycles		2-cycles		2-cycles	
Contact Parting Time			1.5-Cycles		1.5-Cycles		1.5-Cycles	
BUS			Total ¹	Symm ²	Total ¹	Symm ²	Total ¹	Symm ²
59343	STJOT1Y	161.00	1.969	1.969	1.969	1.969	0.000	0.000

59393	STJOE7	345.00	22.139	18.233	22.139	18.234	0.000	0.001
KCPL			Fault Current (kA) without GEN-2010-041		Fault Current (kA) with GEN-2010-041		Fault Current Increase (kA) with GEN-2010-041	
Rated Interrupting Time			2-cycles		2-cycles		2-cycles	
Contact Parting Time			1.5-Cycles		1.5-Cycles		1.5-Cycles	
BUS			Total¹	Symm²	Total¹	Symm²	Total¹	Symm²
57972	HAWTH 7	345.00	35.592	27.698	35.592	27.698	0.000	0.000
57982	IATAN 7	345.00	27.620	21.444	27.621	21.444	0.001	0.000
58031	GRNWOOD5	161.00	41.348	34.925	41.348	34.925	0.000	0.000
58032	MERRIAM5	161.00	33.740	30.055	33.740	30.055	0.000	0.000
58039	LENEXAN5	161.00	34.396	29.330	34.396	29.330	0.000	0.000
58041	SHAWNEE5	161.00	31.823	27.307	31.823	27.307	0.000	0.000
58049	CEDRCRK5	161.00	34.254	28.883	34.255	28.883	0.001	0.000
KACY			Fault Current (kA) without GEN-2010-041		Fault Current (kA) with GEN-2010-041		Fault Current Increase (kA) with GEN-2010-041	
Rated Interrupting Time			2-cycles		2-cycles		2-cycles	
Contact Parting Time			1.5-Cycles		1.5-Cycles		1.5-Cycles	
BUS			Total¹	Symm²	Total¹	Symm²	Total¹	Symm²
58742	METROP 5	161.00	31.635	26.577	31.635	26.578	0.000	0.001
MEC			Fault Current (kA) without GEN-2010-041		Fault Current (kA) with GEN-2010-041		Fault Current Increase (kA) with GEN-2010-041	
Rated Interrupting Time			2-cycles		2-cycles		2-cycles	
Contact Parting Time			1.5-Cycles		1.5-Cycles		1.5-Cycles	
BUS			Total¹	Symm²	Total¹	Symm²	Total¹	Symm²
63801	CBLUFFS5	161.00	54.959	42.855	54.959	42.855	0.000	0.000
64060	BOONVIL3	345.00	24.622	19.257	24.623	19.257	0.001	0.000
635019	ATCHSN 3	345.00	22.015	17.863	22.017	17.864	0.002	0.001
635020	ATCHSNT3	345.00	22.198	17.997	22.199	17.998	0.001	0.001
NPPD			Fault Current (kA) without GEN-2010-041		Fault Current (kA) with GEN-2010-041		Fault Current Increase (kA) with GEN-2010-041	
Rated Interrupting Time			2-cycles		2-cycles		2-cycles	
Contact Parting Time			1.5-Cycles		1.5-Cycles		1.5-Cycles	
BUS			Total¹	Symm²	Total¹	Symm²	Total¹	Symm²
64020	HARBINE7	115.00	8.299	7.992	8.300	7.993	0.001	0.001
64042	STEELEC7	115.00	5.187	4.968	5.188	4.969	0.001	0.001
64709	COOPER1G	22.000	468.792	364.003	468.811	364.018	0.019	0.015
64741	BEAT. S7	115.00	5.911	5.685	5.911	5.686	0.000	0.001
64742	BEAT. S9	34.500	6.838	5.862	6.838	5.863	0.000	0.001
64743	BEATRCE7	115.00	16.344	14.279	16.346	14.281	0.002	0.002
64744	BEATRCE9	34.500	12.900	10.030	12.901	10.031	0.001	0.001

64773	CLATONA7	115.00	11.414	11.018	11.415	11.018	0.001	0.000
64786	COOPER 3	345.00	41.110	31.999	41.114	32.002	0.004	0.002
64787	COOPER 5	161.00	31.582	24.527	31.593	24.535	0.011	0.008
64815	FAIRBRY7	115.00	6.314	5.580	6.314	5.580	0.000	0.000
64864	HUMBOLT7	115.00	9.588	7.536	9.630	7.551	0.042	0.015
64865	HUMBOLT9	34.500	3.265	2.539	3.267	2.540	0.002	0.001
64896	MCCOOL 3	345.00	11.685	10.044	11.685	10.044	0.000	0.000
64902	MOORE 3	345.00	25.033	19.744	25.033	19.745	0.000	0.001
64933	PAULINE3	345.00	8.088	6.973	8.088	6.973	0.000	0.000
64959	SHELDON7	115.00	43.805	34.163	43.806	34.165	0.001	0.001
64973	STEINER7	115.00	4.993	4.865	4.997	4.869	0.004	0.004
65024	COOPER Y	345.00	16.170	12.560	16.176	12.565	0.006	0.005
65033	HUMBLT Y	161.00	6.951	5.415	6.985	5.436	0.034	0.021
65036	MOORE Y	345.00	254.378	251.363	254.474	251.459	0.096	0.096
65051	BEATGT1G	13.800	109.016	84.818	109.017	84.819	0.001	0.001
65052	BEATGT2G	13.800	109.019	84.814	109.020	84.815	0.001	0.001
65053	BEATST3G	13.800	106.053	82.354	106.054	82.355	0.001	0.001
65054	BPS SUB7	115.00	24.462	19.136	24.463	19.138	0.001	0.002
65061	COOPER 2Y	345.00	16.170	12.560	16.176	12.565	0.006	0.005
65566	S966 8	69.000	0.608	0.493	0.608	0.493	0.000	0.000
LES			Fault Current (kA) without GEN-2010-041		Fault Current (kA) with GEN-2010-041		Fault Current Increase (kA) with GEN-2010-041	
Rated Interrupting Time			2-cycles		2-cycles		2-cycles	
Contact Parting Time			1.5-Cycles		1.5-Cycles		1.5-Cycles	
BUS			Total ¹	Symm ²	Total ¹	Symm ²	Total ¹	Symm ²
65720	NW68HOL3	345.00	17.717	14.461	17.718	14.462	0.001	0.001
65789	SELINC 3	345.00	23.596	19.161	23.596	19.161	0.000	0.000
OPPD			Fault Current (kA) without GEN-2010-041		Fault Current (kA) with GEN-2010-041		Fault Current Increase (kA) with GEN-2010-041	
Rated Interrupting Time			2-cycles		2-cycles		2-cycles	
Contact Parting Time			1.5-Cycles		1.5-Cycles		1.5-Cycles	
BUS			Total ¹	Symm ²	Total ¹	Symm ²	Total ¹	Symm ²
64722	AUBURN 8	69.000	5.384	4.567	5.386	4.569	0.002	0.002
64789	CORNFLD8	69.000	2.085	2.040	2.086	2.041	0.001	0.001
64863	HUMBOLT5	161.00	10.319	8.759	10.378	8.788	0.059	0.029
64914	NEHAWKA8	69.000	5.180	4.963	5.180	4.964	0.000	0.001
64987	TEKAMAH5	161.00	9.669	9.235	9.669	9.235	0.000	0.000
65301	FT CAL1G	22.000	258.531	200.783	258.532	200.785	0.001	0.001
65302	NEBCTY1G	18.000	360.211	279.695	360.214	279.698	0.003	0.003
65303	N OMA 1G	13.800	106.728	83.074	106.728	83.075	0.000	0.001

65304	N OMA 2G	13.800	157.656	122.425	157.656	122.425	0.000	0.000
65305	N OMA 3G	13.800	151.333	117.523	151.333	117.523	0.000	0.000
65306	N OMA 4G	15.000	165.856	128.766	165.856	128.766	0.000	0.000
65307	N OMA 5G	20.000	146.648	113.874	146.648	113.874	0.000	0.000
65308	JONES 1G	13.800	74.262	57.650	74.262	57.650	0.000	0.000
65309	JONES 2G	13.800	74.207	57.612	74.207	57.612	0.000	0.000
65310	SCBSD G	4.2000	29.919	23.326	29.919	23.326	0.000	0.000
65311	SARPY 1G	13.800	67.217	52.196	67.217	52.196	0.000	0.000
65312	SARPY 2G	13.800	67.597	52.492	67.597	52.492	0.000	0.000
65313	SARPY 3G	13.800	128.471	99.755	128.472	99.755	0.001	0.000
65314	SARPY 4G	13.800	68.425	53.146	68.425	53.146	0.000	0.000
65315	SARPY 5G	13.800	68.558	53.224	68.558	53.224	0.000	0.000
65316	CASS 1G	15.000	171.608	133.442	171.608	133.442	0.000	0.000
65317	CASS 2G	15.000	172.074	133.807	172.074	133.807	0.000	0.000
65322	NEBCTY2G	23.000	316.128	245.496	316.130	245.497	0.002	0.001
65330	SARP4&5T	161.00	25.240	19.594	25.241	19.594	0.001	0.000
65334	S3451T3T	345.00	23.807	18.485	23.807	18.485	0.000	0.000
65335	S3451T4T	345.00	23.841	18.512	23.842	18.512	0.001	0.000
65336	S1254T1T	345.00	20.599	15.993	20.599	15.993	0.000	0.000
65337	S3455T1T	345.00	42.225	36.331	42.226	36.332	0.001	0.001
65338	S3456T4T	345.00	10.694	8.305	10.694	8.305	0.000	0.000
65339	S3459T3T	345.00	28.812	23.228	28.813	23.229	0.001	0.001
65351	S3451 3	345.00	31.205	24.241	31.205	24.241	0.000	0.000
65354	S3454 3	345.00	33.502	26.224	33.502	26.224	0.000	0.000
65355	S3455 3	345.00	40.883	31.740	40.884	31.741	0.001	0.001
65356	S3456 3	345.00	46.769	36.475	46.770	36.476	0.001	0.001
65358	S3458 3	345.00	40.284	31.280	40.285	31.281	0.001	0.001
65359	S3459 3	345.00	31.825	24.733	31.825	24.733	0.000	0.000
65360	S3740 3	345.00	25.374	19.785	25.374	19.785	0.000	0.000
65380	S1201T1T	161.00	17.000	13.203	17.000	13.203	0.000	0.000
65381	S1206T1T	161.00	21.919	17.024	21.919	17.024	0.000	0.000
65382	S1206T2T	161.00	20.606	16.030	20.607	16.030	0.001	0.000
65383	S1209T1T	161.00	22.977	17.847	22.977	17.847	0.000	0.000
65384	S1210T7T	161.00	17.417	14.608	17.418	14.608	0.001	0.000
65385	S1211T1T	69.000	41.233	32.159	41.233	32.159	0.000	0.000
65386	S1214T1T	161.00	5.831	4.725	5.831	4.725	0.000	0.000
65387	S1217T1T	161.00	15.829	12.328	15.829	12.328	0.000	0.000
65388	S1221T9T	161.00	16.045	12.500	16.045	12.500	0.000	0.000
65389	S1250T1T	161.00	14.198	11.024	14.198	11.024	0.000	0.000
65390	S1263T1T	161.00	72.930	72.930	72.331	72.331	-0.599	-0.599

65391	S975T4 T	161.00	6.426	4.989	6.457	5.015	0.031	0.026
65392	S3455T3T	345.00	55.712	50.077	55.714	50.079	0.002	0.002
65401	S1201 5	161.00	39.255	32.606	39.255	32.606	0.000	0.000
65405	S1305 5	161.00	36.755	28.684	36.755	28.684	0.000	0.000
65406	S1206 5	161.00	64.188	49.858	64.189	49.859	0.001	0.001
65409	S1209 5	161.00	52.057	40.645	52.058	40.646	0.001	0.001
65410	S1210 5	161.00	33.167	28.210	33.167	28.210	0.000	0.000
65411	S1211 5	161.00	51.950	40.327	51.950	40.328	0.000	0.001
65414	S1214 5	161.00	12.825	11.784	12.825	11.784	0.000	0.000
65416	S1216 5	161.00	37.717	30.363	37.718	30.363	0.001	0.000
65417	S1217 5	161.00	40.114	32.927	40.114	32.927	0.000	0.000
65420	S1220 5	161.00	34.426	29.314	34.426	29.314	0.000	0.000
65421	S1221 5	161.00	38.267	33.285	38.267	33.286	0.000	0.001
65422	S1222 5	161.00	32.685	27.828	32.685	27.828	0.000	0.000
65426	S1226 5	161.00	27.955	23.995	27.955	23.995	0.000	0.000
65427	S1227 5	161.00	37.338	31.629	37.338	31.630	0.000	0.001
65429	S1229 5	161.00	34.864	29.258	34.864	29.258	0.000	0.000
65431	S1231 5	161.00	47.959	40.018	47.959	40.019	0.000	0.001
65432	S1232 5	161.00	29.952	26.550	29.952	26.551	0.000	0.001
65433	S1233 5	161.00	31.343	27.084	31.343	27.084	0.000	0.000
65434	S1234 5	161.00	28.029	24.644	28.029	24.644	0.000	0.000
65435	S1235 5	161.00	33.877	29.547	33.877	29.547	0.000	0.000
65436	S1236 5	161.00	20.088	18.113	20.088	18.113	0.000	0.000
65437	S1237 5	161.00	19.759	17.892	19.759	17.892	0.000	0.000
65441	S1341 5	161.00	36.306	28.338	36.306	28.338	0.000	0.000
65443	S1343 5	161.00	30.528	26.358	30.528	26.358	0.000	0.000
65444	S1244 5	161.00	24.560	21.201	24.561	21.202	0.001	0.001
65445	S1345 5	161.00	17.202	15.653	17.202	15.653	0.000	0.000
65448	S1248 5	161.00	22.996	21.205	22.996	21.205	0.000	0.000
65449	S1249 5	161.00	26.697	22.561	26.698	22.562	0.001	0.001
65450	S1250 5	161.00	41.707	35.621	41.708	35.622	0.001	0.001
65451	S1251 5	161.00	45.525	35.477	45.525	35.477	0.000	0.000
65452	S1252 5	161.00	22.062	19.905	22.062	19.905	0.000	0.000
65453	S1253 5	161.00	27.292	24.241	27.292	24.242	0.000	0.001
65454	S1254 5	161.00	37.647	29.242	37.647	29.243	0.000	0.001
65455	S1255 5	161.00	57.937	44.988	57.938	44.988	0.001	0.000
65456	S1256 5	161.00	23.513	20.896	23.513	20.896	0.000	0.000
65457	S1357 5	161.00	29.222	26.825	29.222	26.825	0.000	0.000
65458	S1258 5	161.00	6.622	6.060	6.626	6.063	0.004	0.003
65459	S1259 5	161.00	39.674	33.080	39.674	33.080	0.000	0.000

65460	S1260 5 161.00	30.010	26.379	30.010	26.380	0.000	0.001
65463	S1263 5 161.00	9.536	8.533	9.551	8.544	0.015	0.011
65478	S1278 5 161.00	28.925	25.867	28.926	25.867	0.001	0.000
65480	S1280 5 161.00	12.528	10.862	12.564	10.884	0.036	0.022
65481	S1281 5 161.00	29.704	25.356	29.704	25.356	0.000	0.000
65486	S1286 5 161.00	31.909	27.392	31.909	27.393	0.000	0.001
65487	S1287 5 161.00	20.053	18.135	20.053	18.135	0.000	0.000
65497	S1297 5 161.00	21.810	19.148	21.810	19.148	0.000	0.000
65498	S1298 5 161.00	38.589	30.049	38.589	30.049	0.000	0.000
65499	S1299 5 161.00	34.482	29.162	34.483	29.162	0.001	0.000
65500	S900 8 69.000	8.311	8.050	8.311	8.050	0.000	0.000
65501	S901 8 69.000	37.401	29.267	37.401	29.267	0.000	0.000
65502	S902 8 69.000	9.067	8.680	9.067	8.680	0.000	0.000
65504	S904 8 69.000	9.283	8.845	9.283	8.845	0.000	0.000
65507	S907 8 69.000	22.335	20.182	22.335	20.183	0.000	0.001
65508	S908 8 69.000	21.277	19.613	21.277	19.613	0.000	0.000
65509	S909 8 69.000	35.262	27.710	35.262	27.710	0.000	0.000
65510	S910 8 69.000	31.416	26.879	31.416	26.880	0.000	0.001
65511	S911 8 69.000	37.606	29.200	37.606	29.200	0.000	0.000
65512	S912 8 69.000	24.907	22.419	24.907	22.419	0.000	0.000
65513	S913 8 69.000	19.399	18.188	19.399	18.188	0.000	0.000
65514	S914 8 69.000	8.207	7.791	8.207	7.791	0.000	0.000
65516	S916 8 69.000	26.982	23.759	26.982	23.759	0.000	0.000
65517	S917 8 69.000	33.257	26.041	33.257	26.041	0.000	0.000
65518	S918 8 69.000	24.722	23.223	24.722	23.223	0.000	0.000
65519	S919 8 69.000	24.835	22.497	24.835	22.497	0.000	0.000
65521	S921 8 69.000	32.017	26.144	32.017	26.144	0.000	0.000
65523	S923 8 69.000	20.923	19.125	20.923	19.125	0.000	0.000
65524	S924 8 69.000	26.922	23.491	26.922	23.491	0.000	0.000
65528	S928 8 69.000	16.342	15.639	16.342	15.639	0.000	0.000
65530	S930 8 69.000	23.751	22.045	23.751	22.045	0.000	0.000
65537	S937 8 69.000	8.844	8.489	8.844	8.489	0.000	0.000
65538	S938 8 69.000	24.214	22.366	24.214	22.366	0.000	0.000
65539	S939 8 69.000	22.660	20.532	22.660	20.532	0.000	0.000
65540	S940 8 69.000	23.183	20.875	23.183	20.875	0.000	0.000
65542	S942 8 69.000	15.999	15.293	15.999	15.293	0.000	0.000
65546	S6846 8 69.000	7.834	7.386	7.834	7.386	0.000	0.000
65550	S950 8 69.000	30.016	23.350	30.016	23.350	0.000	0.000
65561	S961 8 69.000	5.307	5.092	5.307	5.092	0.000	0.000
65562	S962 8 69.000	6.043	5.769	6.044	5.770	0.001	0.001

65563	S963 8 69.000	11.737	10.346	11.746	10.353	0.009	0.007
65564	S964 8 69.000	3.573	3.423	3.575	3.424	0.002	0.001
65565	S965 8 69.000	7.492	7.077	7.504	7.087	0.012	0.010
65567	S967 8 69.000	5.310	5.079	5.311	5.080	0.001	0.001
65568	S968 8 69.000	4.723	4.457	4.724	4.457	0.001	0.000
65569	S969 8 69.000	4.585	4.409	4.585	4.409	0.000	0.000
65570	S970 8 69.000	4.492	4.351	4.493	4.351	0.001	0.000
65571	S971 8 69.000	4.970	4.812	4.970	4.812	0.000	0.000
65572	S972 8 69.000	4.550	4.421	4.550	4.421	0.000	0.000
65573	S973 8 69.000	3.696	3.623	3.697	3.624	0.001	0.001
65574	S974 8 69.000	5.830	5.609	5.830	5.609	0.000	0.000
65575	S975 8 69.000	14.747	11.694	14.808	11.712	0.061	0.018
65576	S976 8 69.000	12.811	10.525	12.811	10.525	0.000	0.000
65577	S977 8 69.000	6.750	6.362	6.751	6.364	0.001	0.002
65579	979TP 8 69.000	6.879	6.678	6.879	6.678	0.000	0.000
65582	S982 8 69.000	4.120	4.000	4.120	4.000	0.000	0.000
65583	S983 8 69.000	7.603	7.214	7.603	7.214	0.000	0.000
65584	S984 8 69.000	7.940	7.627	7.940	7.627	0.000	0.000
65585	S985 8 69.000	8.735	8.351	8.735	8.351	0.000	0.000
65588	S988 8 69.000	3.068	2.973	3.068	2.973	0.000	0.000
65590	990TP 8 69.000	4.121	4.001	4.121	4.001	0.000	0.000
65591	991TP 8 69.000	11.149	9.912	11.149	9.912	0.000	0.000
65592	S992 8 69.000	6.192	5.884	6.192	5.884	0.000	0.000
65593	S993 8 69.000	2.931	2.553	2.931	2.553	0.000	0.000
65594	S994 8 69.000	13.439	12.766	13.439	12.766	0.000	0.000
65595	S995 8 69.000	13.535	12.832	13.535	12.832	0.000	0.000
65600	S906 N 8 69.000	43.504	33.778	43.504	33.778	0.000	0.000
65601	S906 S 8 69.000	43.968	34.291	43.969	34.291	0.001	0.000
65604	S914A 8 69.000	13.354	11.908	13.354	11.908	0.000	0.000
65605	915TP3 8 69.000	14.257	13.282	14.257	13.282	0.000	0.000
65606	915TP9 8 69.000	13.155	12.276	13.155	12.276	0.000	0.000
65607	S915T2 8 69.000	9.962	9.608	9.962	9.608	0.000	0.000
65608	S915T1 8 69.000	12.477	11.735	12.477	11.735	0.000	0.000
65609	S979 8 69.000	6.741	6.545	6.741	6.545	0.000	0.000
65610	S990 8 69.000	2.998	2.914	2.998	2.914	0.000	0.000
65611	S991 8 69.000	9.239	8.593	9.239	8.593	0.000	0.000
65615	ASH GRV8 69.000	7.184	6.972	7.184	6.972	0.000	0.000
65616	AUBRNT 8 69.000	7.326	6.732	7.331	6.737	0.005	0.005
65617	HYDCAP 8 69.000	4.675	4.522	4.675	4.522	0.000	0.000
65618	ENRON 8 69.000	4.523	4.380	4.523	4.380	0.000	0.000

65619	MUD LNG8	69.000	15.766	15.077	15.766	15.077	0.000	0.000
65621	JCT205 8	69.000	25.462	22.663	25.463	22.663	0.001	0.000
65622	PAX MIT8	69.000	12.094	11.615	12.094	11.615	0.000	0.000
65623	SAC623 8	69.000	12.602	11.996	12.602	11.996	0.000	0.000
65624	SAC629 8	69.000	12.429	11.695	12.429	11.695	0.000	0.000
65625	SAC SO 8	69.000	8.134	7.912	8.134	7.912	0.000	0.000
65626	SAC NO 8	69.000	10.407	9.992	10.407	9.992	0.000	0.000
65627	W BROCK8	69.000	13.149	11.060	13.162	11.068	0.013	0.008
65650	TECUMSH8	69.000	3.547	3.043	3.547	3.043	0.000	0.000
65652	NCU903 8	69.000	6.888	6.223	6.888	6.223	0.000	0.000
65653	NC SYRA8	69.000	4.521	4.378	4.521	4.379	0.000	0.001
65654	FREM 6G	13.800	24.537	19.082	24.537	19.082	0.000	0.000
65655	FREM A 8	69.000	17.617	13.738	17.617	13.738	0.000	0.000
65656	FREM B 8	69.000	11.889	9.650	11.889	9.650	0.000	0.000
65657	FREM D 8	69.000	12.727	10.541	12.727	10.541	0.000	0.000
65658	FREM E 8	69.000	9.739	8.524	9.739	8.524	0.000	0.000
65659	FREM F 8	69.000	11.268	9.237	11.268	9.237	0.000	0.000
65660	FREM 7G	13.800	24.530	19.072	24.530	19.072	0.000	0.000
65661	FREM 8G	13.800	73.286	56.922	73.286	56.922	0.000	0.000
65662	FREM 1G	13.800	51.123	39.706	51.123	39.706	0.000	0.000
65663	FREM C 8	69.000	10.813	9.415	10.813	9.415	0.000	0.000
65664	FREM G 8	69.000	16.323	12.675	16.323	12.675	0.000	0.000
65665	S3455T19	13.800	27.137	21.121	27.137	21.121	0.000	0.000
65666	S3456T49	13.800	29.258	22.725	29.258	22.725	0.000	0.000
65667	S1211T19	13.800	40.190	31.203	40.190	31.203	0.000	0.000
65668	S3455T39	13.800	44.871	34.837	44.871	34.837	0.000	0.000
65670	FC1A 5	161.00	41.326	32.081	41.326	32.081	0.000	0.000
65671	FC1A1 9	4.2000	34.296	28.488	34.296	28.488	0.000	0.000
65672	FC1A2 9	4.2000	34.043	28.259	34.043	28.259	0.000	0.000
65673	FC1A3 9	4.2000	27.861	21.643	27.861	21.643	0.000	0.000
65674	FC1A4 9	4.2000	27.881	21.689	27.881	21.689	0.000	0.000
65675	NBAXT1 9	4.2000	60.735	50.689	60.735	50.689	0.000	0.000
65676	NBAXT2 9	4.2000	60.193	50.388	60.193	50.388	0.000	0.000
65677	NBHST1 9	4.2000	29.711	24.015	29.714	24.016	0.003	0.001
65678	NBHST2 9	4.2000	29.882	24.330	29.885	24.332	0.003	0.002
65679	NBHST3 9	4.2000	30.372	24.629	30.374	24.631	0.002	0.002
65680	NBHST4 9	4.2000	30.182	24.421	30.184	24.422	0.002	0.001
65681	NO1 AUX9	2.4000	40.741	31.640	40.741	31.640	0.000	0.000
65682	NO2 AUX9	2.4000	37.350	28.996	37.350	28.996	0.000	0.000
65683	NO3 AUX9	2.4000	48.690	37.812	48.690	37.812	0.000	0.000

65684	NO4 AUX9	2.4000	46.637	36.210	46.637	36.210	0.000	0.000
65685	NO5 AUX9	4.2000	51.562	40.033	51.562	40.033	0.000	0.000
65686	S911 HS9	13.800	10.859	8.789	10.859	8.789	0.000	0.000
65687	S1211HS9	13.800	10.585	8.255	10.585	8.255	0.000	0.000
580071	G10-041GEN1	0.69	0.000	0.000	355.254	275.898	355.254	275.898
645061	FLTWTR1W	0.5750	0.000	1004.135	0.000	1041.232	0.000	37.097
646399	S1399 5	161.00	8.503	7.586	8.641	7.663	0.138	0.077
648500	FLTWTRX9	34.500	19.340	15.013	20.762	16.126	1.422	1.113
648501	FLTWTRY9	13.800	27.511	21.451	28.203	21.995	0.692	0.544

Note 1: For Breakers Rated on a Total Current Basis

Note 2: For Breakers Rated on a Symmetrical Current Basis

Table D-2: 3 – Cycle Breaker

AECI			Fault Current (kA) without GEN-2010-041		Fault Current (kA) with GEN-2010-041		Fault Current Increase (kA) with GEN-2010-041	
Rated Interrupting Time			3-cycles		3-cycles		3-cycles	
Contact Parting Time			2-Cycles		2-Cycles		2-Cycles	
BUS			Total ¹	Symm ²	Total ¹	Symm ²	Total ¹	Symm ²
34913	MINTWD	345.00	18.231	15.597	18.232	15.597	0.001	0.000
34914	MINTWDG	34.500	184.286	159.864	184.287	159.865	0.001	0.001
96039	7FAIRPT	345.00	14.105	12.842	14.105	12.842	0.000	0.000
WERE			Fault Current (kA) without GEN-2010-041		Fault Current (kA) with GEN-2010-041		Fault Current Increase (kA) with GEN-2010-041	
Rated Interrupting Time			3-cycles		3-cycles		3-cycles	
Contact Parting Time			2-Cycles		2-Cycles		2-Cycles	
BUS			Total ¹	Symm ²	Total ¹	Symm ²	Total ¹	Symm ²
54016	2007-15T	161.00	7.737	7.411	7.839	7.474	0.102	0.063
56654	CLR_1	0.5750	441.125	422.136	441.310	422.283	0.185	0.147
56655	CLR_2	0.5750	423.459	406.253	423.616	406.382	0.157	0.129
56656	CLR_3	0.5750	423.294	406.648	423.450	406.778	0.156	0.130
56657	CLR_4	0.5750	401.237	385.448	401.364	385.558	0.127	0.110
56658	CLR_5	0.5750	443.748	428.838	443.927	428.991	0.179	0.153
56659	MAIN XFMR	LS34.500	23.999	21.352	24.115	21.388	0.116	0.036
56660	2007-D	13.800	40.502	34.559	40.789	34.767	0.287	0.209
56661	LEC U3	14.400	63.447	53.137	63.447	53.137	0.000	0.000
56664	WTG EQ 1	34.500	10.735	10.734	10.743	10.742	0.008	0.008
56665	WTG EQ 2	34.500	9.013	9.012	9.019	9.017	0.006	0.005
56666	WTG EQ 3	34.500	9.041	9.040	9.046	9.045	0.005	0.005

56667	WTG EQ 4	34.500	7.698	7.697	7.702	7.701	0.004	0.004
56668	WTG EQ 5	34.500	10.769	10.767	10.777	10.775	0.008	0.008
56671	TEC U7	14.400	149.695	124.136	149.696	124.138	0.001	0.001
56672	TEC U8	16.000	100.338	84.256	100.340	84.257	0.002	0.001
56774	SWISVAL7	345.00	14.310	12.714	14.310	12.714	0.000	0.000
56815	SWISVAL1	14.400	49.281	41.855	49.281	41.856	0.000	0.001
56851	AUBURN 6	230.00	13.619	13.076	13.619	13.076	0.000	0.000
56853	LAWHILL6	230.00	21.177	17.830	21.178	17.830	0.001	0.000
56855	MIDLAND6	230.00	16.486	13.931	16.487	13.931	0.001	0.000
56856	SWISVAL6	230.00	20.219	17.934	20.219	17.934	0.000	0.000
56857	TECHILL6	230.00	13.350	11.307	13.351	11.308	0.001	0.001
56863	MORRIS 6	230.00	14.762	12.496	14.762	12.496	0.000	0.000
56884	MIDLAND1	18.000	60.110	49.943	60.110	49.943	0.000	0.000
56886	TECHILL1	13.800	89.185	75.030	89.189	75.034	0.004	0.004
56913	KELLY 5	161.00	6.662	6.633	6.701	6.660	0.039	0.027
56920	TECHILL5	161.00	8.779	7.439	8.782	7.441	0.003	0.003
56921	WM BROSS	161.00	4.439	4.438	4.440	4.439	0.001	0.001
56936	MIDIAN 5	161.00	5.291	4.499	5.291	4.499	0.000	0.000
56942	KELLY 1	13.800	6.141	5.170	6.147	5.175	0.006	0.004
56956	MIDIAN 1	12.470	8.707	7.330	8.707	7.330	0.000	0.000
56986	BENTON 4	138.00	30.257	25.622	30.257	25.622	0.000	0.000
56987	BUTLER 4	138.00	11.185	10.964	11.185	10.964	0.000	0.000
56990	MIDIAN 4	138.00	11.545	11.228	11.545	11.228	0.000	0.000
57082	MIDIAN 1	13.200	22.706	20.775	22.706	20.775	0.000	0.000
57152	CIRCLVL3	115.00	6.252	6.251	6.255	6.254	0.003	0.003
57153	COLINE 3	115.00	23.810	23.166	23.812	23.168	0.002	0.002
57156	54&MERI3	115.00	17.912	17.171	17.913	17.172	0.001	0.001
57158	4CORNER3	115.00	6.115	6.114	6.115	6.114	0.000	0.000
57160	41CALIF3	115.00	18.589	18.586	18.590	18.587	0.001	0.001
57162	GOODYR 3	115.00	19.335	18.914	19.336	18.916	0.001	0.002
57163	HOYT 3	115.00	29.100	24.539	29.103	24.542	0.003	0.003
57164	HTI 3	115.00	13.923	13.898	13.924	13.900	0.001	0.002
57165	HTI JCT3	115.00	18.961	16.934	18.963	16.936	0.002	0.002
57166	INDIANH3	115.00	17.658	17.261	17.658	17.262	0.000	0.001
57168	N TYLER3	115.00	17.276	16.933	17.277	16.934	0.001	0.001
57169	NTHLAND3	115.00	15.512	14.961	15.512	14.962	0.000	0.001
57172	QUINTON3	115.00	18.558	18.223	18.559	18.224	0.001	0.001
57173	SCRANTN3	115.00	5.592	5.592	5.592	5.592	0.000	0.000
57176	SHAWNEE3	115.00	12.288	12.287	12.289	12.287	0.001	0.000
57177	6 GOLDN3	115.00	17.014	16.487	17.015	16.488	0.001	0.001

57180	TEC E 3	115.00	36.553	31.381	36.556	31.384	0.003	0.003
57182	TECHILE3	115.00	38.322	32.686	38.326	32.689	0.004	0.003
57184	12&CLAY3	115.00	17.530	17.271	17.531	17.272	0.001	0.001
57186	29 GAGE3	115.00	18.486	18.305	18.487	18.306	0.001	0.001
57187	27CROCO3	115.00	21.382	21.379	21.384	21.380	0.002	0.001
57188	27CROCJ3	115.00	20.980	20.976	20.982	20.978	0.002	0.002
57192	HOOKJCT3	115.00	25.023	23.529	25.025	23.531	0.002	0.002
57212	BROWNCO3	115.00	2.631	2.630	2.633	2.632	0.002	0.002
57217	KELLY 3	115.00	8.155	7.996	8.194	8.017	0.039	0.021
57219	TONGATP3	115.00	14.169	13.077	14.169	13.077	0.000	0.000
57234	BISMARK3	115.00	17.596	17.094	17.597	17.094	0.001	0.000
57236	COOP 3	115.00	16.698	16.546	16.698	16.547	0.000	0.001
57237	CRAIG J3	115.00	12.648	12.234	12.648	12.234	0.000	0.000
57241	FMC 3	115.00	16.882	16.276	16.883	16.276	0.001	0.000
57243	JAGGARD3	115.00	10.866	10.864	10.866	10.864	0.000	0.000
57244	JARBALO3	115.00	18.938	17.462	18.938	17.462	0.000	0.000
57248	LEC U3 3	115.00	31.248	26.332	31.248	26.333	0.000	0.001
57250	LWRNCHL3	115.00	39.367	32.996	39.368	32.996	0.001	0.000
57252	MIDLAND3	115.00	30.863	26.209	30.863	26.209	0.000	0.000
57253	MOCKBRD3	115.00	17.575	17.191	17.575	17.191	0.000	0.000
57261	PENTAGN3	115.00	14.495	14.020	14.495	14.020	0.000	0.000
57269	STULL 3	115.00	12.664	12.662	12.664	12.663	0.000	0.001
57270	STULL T3	115.00	12.787	12.785	12.787	12.785	0.000	0.000
57271	SWLWRNC3	115.00	18.865	17.974	18.865	17.974	0.000	0.000
57282	MUND 3	115.00	13.171	12.428	13.171	12.429	0.000	0.001
57322	BAILEYV3	115.00	4.701	4.700	4.705	4.705	0.004	0.005
57331	KING HL3	115.00	5.986	5.985	5.994	5.993	0.008	0.008
57332	KNOB HL3	115.00	4.764	4.763	4.765	4.764	0.001	0.001
57337	SENECA 3	115.00	5.402	5.360	5.415	5.367	0.013	0.007
57338	SMITTYV3	115.00	4.330	4.329	4.332	4.332	0.002	0.003
57443	COLINE 1	34.500	4.948	4.178	4.948	4.178	0.000	0.000
57448	TEC 1	13.800	15.624	13.248	15.624	13.249	0.000	0.001
57452	LEC 1	34.500	2.571	2.149	2.571	2.149	0.000	0.000
57456	COLINE 2	69.000	11.109	9.982	11.109	9.982	0.000	0.000
57457	DEERCRK2	69.000	11.561	11.041	11.561	11.041	0.000	0.000
57458	ROCKCRK2	69.000	4.145	4.145	4.145	4.145	0.000	0.000
57460	SANTAFJ2	69.000	12.760	11.777	12.760	11.777	0.000	0.000
57462	TEC 2	69.000	19.635	16.596	19.635	16.597	0.000	0.001
57463	TEC GT 2	69.000	18.274	15.478	18.274	15.478	0.000	0.000
57482	VALLEY12	69.000	3.417	3.417	3.417	3.417	0.000	0.000

57496	LEC 2	69.000	5.673	4.774	5.673	4.774	0.000	0.000
57597	MIDIAN 2	69.000	14.869	13.974	14.869	13.974	0.000	0.000
57884	UCB 1	13.800	31.077	26.165	31.078	26.165	0.001	0.000
MIPU			Fault Current (kA) without GEN-2010-041		Fault Current (kA) with GEN-2010-041		Fault Current Increase (kA) with GEN-2010-041	
Rated Interrupting Time			3-cycles		3-cycles		3-cycles	
Contact Parting Time			2-Cycles		2-Cycles		2-Cycles	
BUS			Total¹	Symm²	Total¹	Symm²	Total¹	Symm²
59343	STJOT1Y	161.00	1.969	1.969	1.969	1.969	0.000	0.000
59393	STJOE7	345.00	20.736	18.233	20.736	18.234	0.000	0.001
KCPL			Fault Current (kA) without GEN-2010-041		Fault Current (kA) with GEN-2010-041		Fault Current Increase (kA) with GEN-2010-041	
Rated Interrupting Time			3-cycles		3-cycles		3-cycles	
Contact Parting Time			2-Cycles		2-Cycles		2-Cycles	
BUS			Total¹	Symm²	Total¹	Symm²	Total¹	Symm²
57972	HAWTH 7	345.00	33.776	28.569	33.776	28.569	0.000	0.000
57982	IATAN 7	345.00	26.620	22.288	26.621	22.288	0.001	0.000
58031	GRNWOOD5	161.00	38.768	34.925	38.768	34.925	0.000	0.000
58032	MERRIAM5	161.00	31.706	30.055	31.706	30.055	0.000	0.000
58039	LENEXAN5	161.00	32.262	29.330	32.263	29.330	0.001	0.000
58041	SHAWNEE5	161.00	29.857	27.307	29.857	27.307	0.000	0.000
58049	CEDRCKR5	161.00	32.115	28.883	32.115	28.883	0.000	0.000
KACY			Fault Current (kA) without GEN-2010-041		Fault Current (kA) with GEN-2010-041		Fault Current Increase (kA) with GEN-2010-041	
Rated Interrupting Time			3-cycles		3-cycles		3-cycles	
Contact Parting Time			2-Cycles		2-Cycles		2-Cycles	
BUS			Total¹	Symm²	Total¹	Symm²	Total¹	Symm²
58742	METROP 5	161.00	29.654	26.577	29.654	26.578	0.000	0.001
MEC			Fault Current (kA) without GEN-2010-041		Fault Current (kA) with GEN-2010-041		Fault Current Increase (kA) with GEN-2010-041	
Rated Interrupting Time			3-cycles		3-cycles		3-cycles	
Contact Parting Time			2-Cycles		2-Cycles		2-Cycles	
BUS			Total¹	Symm²	Total¹	Symm²	Total¹	Symm²
63801	CBLUFFS5	161.00	51.604	43.827	51.604	43.827	0.000	0.000
64060	BOONVIL3	345.00	23.008	19.549	23.008	19.549	0.000	0.000
635019	ATCHSN 3	345.00	20.608	17.863	20.609	17.864	0.001	0.001
635020	ATCHSNT3	345.00	20.778	17.997	20.780	17.998	0.002	0.001
NPPD			Fault Current (kA) without GEN-2010-041		Fault Current (kA) with GEN-2010-041		Fault Current Increase (kA) with GEN-2010-041	
Rated Interrupting Time			3-cycles		3-cycles		3-cycles	

Contact Parting Time			2-Cycles		2-Cycles		2-Cycles	
BUS			Total ¹	Symm ²	Total ¹	Symm ²	Total ¹	Symm ²
64020	HARBINE7	115.00	7.993	7.992	7.994	7.993	0.001	0.001
64042	STEELEC7	115.00	4.969	4.968	4.970	4.969	0.001	0.001
64709	COOPER1G	22.000	458.587	383.596	458.606	383.612	0.019	0.016
64741	BEAT. S7	115.00	5.686	5.685	5.687	5.686	0.001	0.001
64742	BEAT. S9	34.500	6.399	5.862	6.399	5.863	0.000	0.001
64743	BEATRCE7	115.00	15.346	14.279	15.348	14.281	0.002	0.002
64744	BEATRCE9	34.500	12.045	10.180	12.045	10.181	0.000	0.001
64773	CLATONA7	115.00	11.019	11.018	11.020	11.018	0.001	0.000
64786	COOPER 3	345.00	38.829	32.918	38.833	32.920	0.004	0.002
64787	COOPER 5	161.00	30.206	25.407	30.217	25.415	0.011	0.008
64815	FAIRBRY7	115.00	5.913	5.580	5.913	5.580	0.000	0.000
64864	HUMBOLT7	115.00	8.964	7.640	9.003	7.669	0.039	0.028
64865	HUMBOLT9	34.500	3.054	2.582	3.055	2.582	0.001	0.001
64896	MCCOOL 3	345.00	10.964	10.044	10.964	10.044	0.000	0.000
64902	MOORE 3	345.00	23.407	19.968	23.407	19.969	0.000	0.001
64933	PAULINE3	345.00	7.590	6.973	7.590	6.973	0.000	0.000
64959	SHELDON7	115.00	41.087	34.879	41.088	34.880	0.001	0.001
64973	STEINER7	115.00	4.866	4.865	4.869	4.869	0.003	0.004
65024	COOPER Y	345.00	15.723	13.211	15.729	13.215	0.006	0.005
65033	HUMBLT Y	161.00	6.492	5.496	6.523	5.518	0.031	0.021
65036	MOORE Y	345.00	251.376	251.363	251.471	251.459	0.095	0.096
65051	BEATGT1G	13.800	103.622	87.564	103.623	87.565	0.001	0.001
65052	BEATGT2G	13.800	103.663	87.577	103.664	87.578	0.001	0.001
65053	BEATST3G	13.800	103.715	86.707	103.716	86.708	0.001	0.001
65054	BPS SUB7	115.00	22.859	19.426	22.860	19.428	0.001	0.002
65061	COOPER 2Y	345.00	15.723	13.211	15.729	13.215	0.006	0.005
65566	S966 8	69.000	0.568	0.493	0.568	0.493	0.000	0.000
LES			Fault Current (kA) without GEN-2010-041		Fault Current (kA) with GEN-2010-041		Fault Current Increase (kA) with GEN-2010-041	
Rated Interrupting Time			3-cycles		3-cycles		3-cycles	
Contact Parting Time			2-Cycles		2-Cycles		2-Cycles	
BUS			Total ¹	Symm ²	Total ¹	Symm ²	Total ¹	Symm ²
65720	NW68HOL3	345.00	16.589	14.461	16.589	14.462	0.000	0.001
65789	SELINC 3	345.00	22.088	19.161	22.089	19.161	0.001	0.000
OPPD			Fault Current (kA) without GEN-2010-041		Fault Current (kA) with GEN-2010-041		Fault Current Increase (kA) with GEN-2010-041	
Rated Interrupting Time			3-cycles		3-cycles		3-cycles	
Contact Parting Time			2-Cycles		2-Cycles		2-Cycles	

BUS			Total ¹	Symm ²	Total ¹	Symm ²	Total ¹	Symm ²
64722	AUBURN 8	69.000	5.049	4.567	5.051	4.569	0.002	0.002
64789	CORNFLD8	69.000	2.041	2.040	2.041	2.041	0.000	0.001
64863	HUMBOLT5	161.00	9.677	8.759	9.732	8.788	0.055	0.029
64914	NEHAWKA8	69.000	4.964	4.963	4.964	4.964	0.000	0.001
64987	TEKAMAHS	161.00	9.236	9.235	9.236	9.235	0.000	0.000
65301	FT CAL1G	22.000	249.310	209.636	249.310	209.638	0.000	0.001
65302	NEBCTY1G	18.000	352.378	294.755	352.381	294.757	0.003	0.003
65303	N OMA 1G	13.800	101.058	85.580	101.059	85.581	0.001	0.001
65304	N OMA 2G	13.800	152.161	128.051	152.161	128.051	0.000	0.000
65305	N OMA 3G	13.800	145.939	122.725	145.939	122.725	0.000	0.000
65306	N OMA 4G	15.000	162.253	135.407	162.254	135.407	0.001	0.000
65307	N OMA 5G	20.000	141.537	119.110	141.537	119.110	0.000	0.000
65308	JONES 1G	13.800	72.658	60.763	72.658	60.763	0.000	0.000
65309	JONES 2G	13.800	72.604	60.719	72.604	60.719	0.000	0.000
65310	SCBSD G	4.2000	28.097	23.861	28.097	23.861	0.000	0.000
65311	SARPY 1G	13.800	65.777	54.958	65.777	54.958	0.000	0.000
65312	SARPY 2G	13.800	66.149	55.269	66.150	55.269	0.001	0.000
65313	SARPY 3G	13.800	125.731	104.972	125.731	104.972	0.000	0.000
65314	SARPY 4G	13.800	66.934	55.988	66.934	55.988	0.000	0.000
65315	SARPY 5G	13.800	67.063	56.097	67.063	56.097	0.000	0.000
65316	CASS 1G	15.000	169.673	140.657	169.673	140.657	0.000	0.000
65317	CASS 2G	15.000	170.112	141.068	170.112	141.068	0.000	0.000
65322	NEBCTY2G	23.000	309.350	258.510	309.352	258.511	0.002	0.001
65330	SARP4&5T	161.00	24.760	20.652	24.760	20.652	0.000	0.000
65334	S3451T3T	345.00	22.246	18.780	22.246	18.780	0.000	0.000
65335	S3451T4T	345.00	22.278	18.808	22.278	18.808	0.000	0.000
65336	S1254T1T	345.00	19.248	16.250	19.249	16.250	0.001	0.000
65337	S3455T1T	345.00	39.621	36.331	39.622	36.332	0.001	0.001
65338	S3456T4T	345.00	11.307	9.372	11.307	9.372	0.000	0.000
65339	S3459T3T	345.00	26.964	23.228	26.964	23.229	0.000	0.001
65351	S3451 3	345.00	29.124	24.636	29.125	24.635	0.001	-0.001
65354	S3454 3	345.00	31.309	26.624	31.310	26.624	0.001	0.000
65355	S3455 3	345.00	38.175	32.170	38.176	32.168	0.001	-0.002
65356	S3456 3	345.00	43.861	37.230	43.862	37.231	0.001	0.001
65358	S3458 3	345.00	38.547	32.409	38.548	32.411	0.001	0.001
65359	S3459 3	345.00	29.713	25.104	29.714	25.104	0.001	0.000
65360	S3740 3	345.00	23.824	20.233	23.825	20.233	0.001	0.000
65380	S1201T1T	161.00	15.864	13.344	15.864	13.344	0.000	0.000
65381	S1206T1T	161.00	21.313	17.907	21.314	17.907	0.001	0.000

65382	S1206T2T	161.00	19.602	16.556	19.602	16.556	0.000	0.000
65383	S1209T1T	161.00	21.449	18.098	21.449	18.098	0.000	0.000
65384	S1210T7T	161.00	16.326	14.608	16.326	14.608	0.000	0.000
65385	S1211T1T	69.000	38.676	32.834	38.676	32.834	0.000	0.000
65386	S1214T1T	161.00	5.453	4.725	5.453	4.725	0.000	0.000
65387	S1217T1T	161.00	14.783	12.512	14.783	12.512	0.000	0.000
65388	S1221T9T	161.00	14.985	12.687	14.985	12.687	0.000	0.000
65389	S1250T1T	161.00	13.821	11.602	13.821	11.602	0.000	0.000
65390	S1263T1T	161.00	72.930	72.930	72.331	72.331	-0.599	-0.599
65391	S975T4 T	161.00	5.999	5.063	6.027	5.082	0.028	0.019
65392	S3455T3T	345.00	52.373	50.077	52.376	50.079	0.003	0.002
65401	S1201 5	161.00	36.780	32.606	36.781	32.606	0.001	0.000
65405	S1305 5	161.00	34.335	29.116	34.335	29.116	0.000	0.000
65406	S1206 5	161.00	61.504	51.645	61.505	51.647	0.001	0.001
65409	S1209 5	161.00	48.632	41.257	48.633	41.258	0.001	0.001
65410	S1210 5	161.00	31.106	28.210	31.106	28.210	0.000	0.000
65411	S1211 5	161.00	48.490	40.820	48.491	40.821	0.001	0.001
65414	S1214 5	161.00	12.068	11.784	12.068	11.784	0.000	0.000
65416	S1216 5	161.00	35.296	30.363	35.296	30.363	0.000	0.000
65417	S1217 5	161.00	37.567	32.927	37.568	32.927	0.001	0.000
65420	S1220 5	161.00	32.289	29.314	32.289	29.314	0.000	0.000
65421	S1221 5	161.00	35.923	33.285	35.924	33.286	0.001	0.001
65422	S1222 5	161.00	30.655	27.828	30.655	27.828	0.000	0.000
65426	S1226 5	161.00	26.228	23.995	26.228	23.995	0.000	0.000
65427	S1227 5	161.00	35.012	31.629	35.013	31.630	0.001	0.001
65429	S1229 5	161.00	32.680	29.258	32.680	29.258	0.000	0.000
65431	S1231 5	161.00	44.944	40.018	44.944	40.019	0.000	0.001
65432	S1232 5	161.00	28.140	26.550	28.140	26.551	0.000	0.001
65433	S1233 5	161.00	29.415	27.084	29.415	27.084	0.000	0.000
65434	S1234 5	161.00	26.324	24.644	26.325	24.644	0.001	0.000
65435	S1235 5	161.00	31.806	29.547	31.806	29.547	0.000	0.000
65436	S1236 5	161.00	18.887	18.113	18.887	18.113	0.000	0.000
65437	S1237 5	161.00	18.581	17.892	18.581	17.892	0.000	0.000
65441	S1341 5	161.00	33.916	28.764	33.916	28.764	0.000	0.000
65443	S1343 5	161.00	28.649	26.358	28.650	26.358	0.001	0.000
65444	S1244 5	161.00	23.048	21.201	23.049	21.202	0.001	0.001
65445	S1345 5	161.00	16.180	15.653	16.180	15.653	0.000	0.000
65448	S1248 5	161.00	21.642	21.205	21.642	21.205	0.000	0.000
65449	S1249 5	161.00	25.032	22.561	25.032	22.562	0.000	0.001
65450	S1250 5	161.00	39.123	35.621	39.123	35.622	0.000	0.001

65451	S1251 5	161.00	42.636	36.140	42.636	36.140	0.000	0.000
65452	S1252 5	161.00	20.743	19.905	20.743	19.905	0.000	0.000
65453	S1253 5	161.00	25.643	24.241	25.644	24.242	0.001	0.001
65454	S1254 5	161.00	35.154	29.625	35.154	29.626	0.000	0.001
65455	S1255 5	161.00	54.143	45.718	54.144	45.718	0.001	0.000
65456	S1256 5	161.00	22.093	20.896	22.093	20.896	0.000	0.000
65457	S1357 5	161.00	27.497	26.825	27.497	26.825	0.000	0.000
65458	S1258 5	161.00	6.231	6.060	6.234	6.063	0.003	0.003
65459	S1259 5	161.00	37.178	33.080	37.179	33.080	0.001	0.000
65460	S1260 5	161.00	28.184	26.379	28.184	26.380	0.000	0.001
65463	S1263 5	161.00	8.963	8.533	8.977	8.544	0.014	0.011
65478	S1278 5	161.00	27.186	25.867	27.186	25.867	0.000	0.000
65480	S1280 5	161.00	11.759	10.862	11.793	10.884	0.034	0.022
65481	S1281 5	161.00	27.862	25.356	27.863	25.356	0.001	0.000
65486	S1286 5	161.00	29.938	27.392	29.938	27.393	0.000	0.001
65487	S1287 5	161.00	18.857	18.135	18.857	18.135	0.000	0.000
65497	S1297 5	161.00	20.482	19.148	20.482	19.148	0.000	0.000
65498	S1298 5	161.00	36.038	30.499	36.038	30.499	0.000	0.000
65499	S1299 5	161.00	32.332	29.162	32.333	29.162	0.001	0.000
65500	S900 8	69.000	8.051	8.050	8.051	8.050	0.000	0.000
65501	S901 8	69.000	34.952	29.713	34.952	29.713	0.000	0.000
65502	S902 8	69.000	8.682	8.680	8.682	8.680	0.000	0.000
65504	S904 8	69.000	8.847	8.845	8.847	8.845	0.000	0.000
65507	S907 8	69.000	21.002	20.182	21.002	20.183	0.000	0.001
65508	S908 8	69.000	20.025	19.613	20.025	19.613	0.000	0.000
65509	S909 8	69.000	32.967	28.101	32.967	28.101	0.000	0.000
65510	S910 8	69.000	29.454	26.879	29.454	26.880	0.000	0.001
65511	S911 8	69.000	35.117	29.598	35.117	29.598	0.000	0.000
65512	S912 8	69.000	23.416	22.419	23.416	22.419	0.000	0.000
65513	S913 8	69.000	18.271	18.188	18.271	18.188	0.000	0.000
65514	S914 8	69.000	7.793	7.791	7.793	7.791	0.000	0.000
65516	S916 8	69.000	25.343	23.759	25.343	23.759	0.000	0.000
65517	S917 8	69.000	31.082	26.439	31.082	26.439	0.000	0.000
65518	S918 8	69.000	23.287	23.223	23.287	23.223	0.000	0.000
65519	S919 8	69.000	23.355	22.497	23.355	22.497	0.000	0.000
65521	S921 8	69.000	29.978	26.144	29.978	26.144	0.000	0.000
65523	S923 8	69.000	19.684	19.125	19.684	19.125	0.000	0.000
65524	S924 8	69.000	25.276	23.491	25.276	23.491	0.000	0.000
65528	S928 8	69.000	15.641	15.639	15.641	15.639	0.000	0.000
65530	S930 8	69.000	22.360	22.045	22.360	22.045	0.000	0.000

65537	S937 8 69.000	8.491	8.489	8.491	8.489	0.000	0.000
65538	S938 8 69.000	22.790	22.366	22.790	22.366	0.000	0.000
65539	S939 8 69.000	21.310	20.532	21.310	20.532	0.000	0.000
65540	S940 8 69.000	21.796	20.875	21.796	20.875	0.000	0.000
65542	S942 8 69.000	15.296	15.293	15.296	15.293	0.000	0.000
65546	S6846 8 69.000	7.387	7.386	7.387	7.386	0.000	0.000
65550	S950 8 69.000	28.075	23.750	28.075	23.750	0.000	0.000
65561	S961 8 69.000	5.093	5.092	5.093	5.092	0.000	0.000
65562	S962 8 69.000	5.770	5.769	5.771	5.770	0.001	0.001
65563	S963 8 69.000	11.024	10.346	11.033	10.353	0.009	0.007
65564	S964 8 69.000	3.423	3.423	3.425	3.424	0.002	0.001
65565	S965 8 69.000	7.079	7.077	7.088	7.087	0.009	0.010
65567	S967 8 69.000	5.080	5.079	5.081	5.080	0.001	0.001
65568	S968 8 69.000	4.460	4.457	4.461	4.457	0.001	0.000
65569	S969 8 69.000	4.409	4.409	4.410	4.409	0.001	0.000
65570	S970 8 69.000	4.352	4.351	4.352	4.351	0.000	0.000
65571	S971 8 69.000	4.812	4.812	4.812	4.812	0.000	0.000
65572	S972 8 69.000	4.421	4.421	4.421	4.421	0.000	0.000
65573	S973 8 69.000	3.623	3.623	3.624	3.624	0.001	0.001
65574	S974 8 69.000	5.609	5.609	5.610	5.609	0.001	0.000
65575	S975 8 69.000	13.792	11.779	13.847	11.820	0.055	0.041
65576	S976 8 69.000	11.998	10.525	11.998	10.525	0.000	0.000
65577	S977 8 69.000	6.364	6.362	6.365	6.364	0.001	0.002
65579	979TP 8 69.000	6.679	6.678	6.679	6.678	0.000	0.000
65582	S982 8 69.000	4.000	4.000	4.000	4.000	0.000	0.000
65583	S983 8 69.000	7.215	7.214	7.215	7.214	0.000	0.000
65584	S984 8 69.000	7.628	7.627	7.628	7.627	0.000	0.000
65585	S985 8 69.000	8.352	8.351	8.352	8.351	0.000	0.000
65588	S988 8 69.000	2.973	2.973	2.973	2.973	0.000	0.000
65590	990TP 8 69.000	4.001	4.001	4.001	4.001	0.000	0.000
65591	991TP 8 69.000	10.476	9.912	10.476	9.912	0.000	0.000
65592	S992 8 69.000	5.885	5.884	5.885	5.884	0.000	0.000
65593	S993 8 69.000	2.751	2.553	2.752	2.553	0.001	0.000
65594	S994 8 69.000	12.769	12.766	12.769	12.766	0.000	0.000
65595	S995 8 69.000	12.834	12.832	12.834	12.832	0.000	0.000
65600	S906 N 8 69.000	40.602	34.169	40.602	34.169	0.000	0.000
65601	S906 S 8 69.000	41.258	35.032	41.258	35.032	0.000	0.000
65604	S914A 8 69.000	12.549	11.908	12.549	11.908	0.000	0.000
65605	915TP3 8 69.000	13.424	13.282	13.424	13.282	0.000	0.000
65606	915TP9 8 69.000	12.388	12.276	12.388	12.276	0.000	0.000

65607	S915T2 8 69.000	9.609	9.608	9.609	9.608	0.000	0.000
65608	S915T1 8 69.000	11.753	11.735	11.753	11.735	0.000	0.000
65609	S979 8 69.000	6.546	6.545	6.546	6.545	0.000	0.000
65610	S990 8 69.000	2.914	2.914	2.914	2.914	0.000	0.000
65611	S991 8 69.000	8.699	8.593	8.699	8.593	0.000	0.000
65615	ASH GRV8 69.000	6.973	6.972	6.973	6.972	0.000	0.000
65616	AUBRNT 8 69.000	6.894	6.732	6.898	6.737	0.004	0.005
65617	HYDCAP 8 69.000	4.523	4.522	4.523	4.522	0.000	0.000
65618	ENRON 8 69.000	4.381	4.380	4.381	4.380	0.000	0.000
65619	MUD LNG8 69.000	15.080	15.077	15.080	15.077	0.000	0.000
65621	JCT205 8 69.000	23.926	22.663	23.927	22.663	0.001	0.000
65622	PAX MIT8 69.000	11.617	11.615	11.617	11.615	0.000	0.000
65623	SAC623 8 69.000	11.999	11.996	11.999	11.996	0.000	0.000
65624	SAC629 8 69.000	11.708	11.695	11.708	11.695	0.000	0.000
65625	SAC SO 8 69.000	7.913	7.912	7.913	7.912	0.000	0.000
65626	SAC NO 8 69.000	9.994	9.992	9.994	9.992	0.000	0.000
65627	W BROCK8 69.000	12.326	11.060	12.339	11.068	0.013	0.008
65650	TECUMSH8 69.000	3.328	3.043	3.328	3.043	0.000	0.000
65652	NCU903 8 69.000	6.476	6.223	6.477	6.223	0.001	0.000
65653	NC SYRA8 69.000	4.379	4.378	4.379	4.379	0.000	0.001
65654	FREM 6G 13.800	24.249	20.109	24.249	20.109	0.000	0.000
65655	FREM A 8 69.000	16.538	14.045	16.538	14.045	0.000	0.000
65656	FREM B 8 69.000	11.129	9.650	11.129	9.650	0.000	0.000
65657	FREM D 8 69.000	11.923	10.541	11.923	10.541	0.000	0.000
65658	FREM E 8 69.000	9.145	8.524	9.145	8.524	0.000	0.000
65659	FREM F 8 69.000	10.552	9.237	10.552	9.237	0.000	0.000
65660	FREM 7G 13.800	24.272	20.130	24.272	20.130	0.000	0.000
65661	FREM 8G 13.800	72.043	59.939	72.043	59.939	0.000	0.000
65662	FREM 1G 13.800	49.623	41.741	49.623	41.741	0.000	0.000
65663	FREM C 8 69.000	10.151	9.415	10.151	9.415	0.000	0.000
65664	FREM G 8 69.000	15.232	12.819	15.232	12.819	0.000	0.000
65665	S3455T19 13.800	25.599	21.712	25.599	21.712	0.000	0.000
65666	S3456T49 13.800	28.189	23.535	28.189	23.535	0.000	0.000
65667	S1211T19 13.800	37.527	31.625	37.527	31.625	0.000	0.000
65668	S3455T39 13.800	43.266	36.367	43.266	36.367	0.000	0.000
65670	FC1A 5 161.00	38.606	32.574	38.607	32.574	0.001	0.000
65671	FC1A1 9 4.2000	32.134	28.488	32.134	28.488	0.000	0.000
65672	FC1A2 9 4.2000	31.896	28.259	31.896	28.259	0.000	0.000
65673	FC1A3 9 4.2000	26.007	21.936	26.007	21.936	0.000	0.000
65674	FC1A4 9 4.2000	26.034	22.014	26.034	22.014	0.000	0.000

65675	NBAXT1 9	4.2000	56.917	50.689	56.917	50.689	0.000	0.000
65676	NBAXT2 9	4.2000	56.416	50.388	56.416	50.388	0.000	0.000
65677	NBHST1 9	4.2000	27.808	24.015	27.810	24.016	0.002	0.001
65678	NBHST2 9	4.2000	27.976	24.330	27.979	24.332	0.003	0.002
65679	NBHST3 9	4.2000	28.430	24.629	28.432	24.631	0.002	0.002
65680	NBHST4 9	4.2000	28.249	24.421	28.252	24.422	0.003	0.001
65681	NO1 AUX9	2.4000	39.868	33.310	39.868	33.310	0.000	0.000
65682	NO2 AUX9	2.4000	36.545	30.558	36.545	30.558	0.000	0.000
65683	NO3 AUX9	2.4000	47.642	39.832	47.642	39.832	0.000	0.000
65684	NO4 AUX9	2.4000	45.629	38.159	45.629	38.159	0.000	0.000
65685	NO5 AUX9	4.2000	50.453	42.179	50.453	42.179	0.000	0.000
65686	S911 HS9	13.800	10.164	8.789	10.164	8.789	0.000	0.000
65687	S1211HS9	13.800	9.935	8.437	9.935	8.437	0.000	0.000
580071	G10-041GEN1	0.69	0.000	0.000	347.584	290.672	347.584	290.672
645061	FLTWTR1W	0.5750	0.000	1056.286	0.000	1094.683	0.000	38.397
646399	S1399 5	161.00	7.991	7.586	8.119	7.663	0.128	0.077
648500	FLTWTRX9	34.500	18.057	15.214	19.391	16.350	1.334	1.136
648501	FLTWTRY9	13.800	25.783	21.873	26.447	22.447	0.664	0.574

Note 1: For Breakers Rated on a Total Current Basis

Note 2: For Breakers Rated on a Symmetrical Current Basis

Table D-3: 5 – Cycle Breaker

AECI		Fault Current (kA) without GEN-2010-041		Fault Current (kA) with GEN-2010-041		Fault Current Increase (kA) with GEN-2010-041	
Rated Interrupting Time		5-cycles		5-cycles		5-cycles	
Contact Parting Time		3-Cycles		3-Cycles		3-Cycles	
BUS		Total ¹	Symm ²	Total ¹	Symm ²	Total ¹	Symm ²
34913	MINTWD 345.00	16.795	15.662	16.795	15.662	0.000	0.000
34914	MINTWDG 34.500	170.694	159.864	170.694	159.865	0.000	0.001
96039	7FAIRPT 345.00	13.297	12.842	13.297	12.842	0.000	0.000
WERE		Fault Current (kA) without GEN-2010-041		Fault Current (kA) with GEN-2010-041		Fault Current Increase (kA) with GEN-2010-041	
Rated Interrupting Time		5-cycles		5-cycles		5-cycles	
Contact Parting Time		3-Cycles		3-Cycles		3-Cycles	
BUS		Total ¹	Symm ²	Total ¹	Symm ²	Total ¹	Symm ²
54016	2007-15T 161.00	7.434	7.411	7.519	7.474	0.085	0.063
56654	CLR_1 0.5750	423.705	422.136	423.871	422.283	0.166	0.147
56655	CLR_2 0.5750	407.128	406.253	407.271	406.382	0.143	0.129

56656	CLR_3	0.5750	407.182	406.648	407.324	406.778	0.142	0.130
56657	CLR_4	0.5750	385.960	385.448	386.078	385.558	0.118	0.110
56658	CLR_5	0.5750	428.838	428.838	428.991	428.991	0.153	0.153
56659	MAIN XFMR LS34.500		22.433	21.352	22.516	21.388	0.083	0.036
56660	2007-D	13.800	37.157	34.651	37.357	34.840	0.200	0.189
56661	LEC U3	14.400	57.924	53.385	57.924	53.385	0.000	0.000
56664	WTG EQ 1	34.500	10.734	10.734	10.742	10.742	0.008	0.008
56665	WTG EQ 2	34.500	9.012	9.012	9.017	9.017	0.005	0.005
56666	WTG EQ 3	34.500	9.040	9.040	9.045	9.045	0.005	0.005
56667	WTG EQ 4	34.500	7.697	7.697	7.701	7.701	0.004	0.004
56668	WTG EQ 5	34.500	10.767	10.767	10.775	10.775	0.008	0.008
56671	TEC U7	14.400	146.103	132.474	146.104	132.475	0.001	0.001
56672	TEC U8	16.000	91.254	84.214	91.256	84.215	0.002	0.001
56774	SWISVAL7	345.00	13.370	12.714	13.370	12.714	0.000	0.000
56815	SWISVAL1	14.400	45.050	41.592	45.050	41.593	0.000	0.001
56851	AUBURN 6	230.00	13.097	13.076	13.098	13.076	0.001	0.000
56853	LAWHILL6	230.00	19.822	18.169	19.822	18.169	0.000	0.000
56855	MIDLAND6	230.00	15.058	13.884	15.058	13.884	0.000	0.000
56856	SWISVAL6	230.00	18.878	17.934	18.879	17.934	0.001	0.000
56857	TECHILL6	230.00	12.107	11.244	12.108	11.245	0.001	0.001
56863	MORRIS 6	230.00	13.378	12.430	13.378	12.430	0.000	0.000
56884	MIDLAND1	18.000	58.136	53.085	58.136	53.085	0.000	0.000
56886	TECHILL1	13.800	83.857	76.914	83.861	76.918	0.004	0.004
56913	KELLY 5	161.00	6.633	6.633	6.660	6.660	0.027	0.027
56920	TECHILL5	161.00	7.967	7.397	7.970	7.399	0.003	0.003
56921	WM BROSS	161.00	4.438	4.438	4.439	4.439	0.001	0.001
56936	MIDIAN 5	161.00	4.829	4.503	4.829	4.503	0.000	0.000
56942	KELLY 1	13.800	5.744	5.265	5.752	5.271	0.008	0.007
56956	MIDIAN 1	12.470	8.142	7.460	8.142	7.460	0.000	0.000
56986	BENTON 4	138.00	27.465	25.605	27.465	25.605	0.000	0.000
56987	BUTLER 4	138.00	10.964	10.964	10.964	10.964	0.000	0.000
56990	MIDIAN 4	138.00	11.228	11.228	11.228	11.228	0.000	0.000
57082	MIDIAN 1	13.200	21.444	20.775	21.444	20.775	0.000	0.000
57152	CIRCLVL3	115.00	6.251	6.251	6.254	6.254	0.003	0.003
57153	COLINE 3	115.00	23.166	23.166	23.168	23.168	0.002	0.002
57156	54&MERI3	115.00	17.216	17.171	17.217	17.172	0.001	0.001
57158	4CORNER3	115.00	6.114	6.114	6.114	6.114	0.000	0.000
57160	41CALIF3	115.00	18.586	18.586	18.587	18.587	0.001	0.001
57162	GOODYR 3	115.00	18.914	18.914	18.916	18.916	0.002	0.002
57163	HOYT 3	115.00	26.259	24.446	26.262	24.449	0.003	0.003

57164	HTI 3 115.00	13.898	13.898	13.900	13.900	0.002	0.002
57165	HTI JCT3 115.00	17.748	16.934	17.751	16.936	0.003	0.002
57166	INDIANH3 115.00	17.261	17.261	17.262	17.262	0.001	0.001
57168	N TYLER3 115.00	16.933	16.933	16.934	16.934	0.001	0.001
57169	NTHLAND3 115.00	14.961	14.961	14.962	14.962	0.001	0.001
57172	QUINTON3 115.00	18.223	18.223	18.224	18.224	0.001	0.001
57173	SCRANTN3 115.00	5.592	5.592	5.592	5.592	0.000	0.000
57176	SHAWNEE3 115.00	12.287	12.287	12.287	12.287	0.000	0.000
57177	6 GOLDN3 115.00	16.487	16.487	16.488	16.488	0.001	0.001
57180	TEC E 3 115.00	33.732	31.452	33.735	31.455	0.003	0.003
57182	TECHILE3 115.00	35.131	32.764	35.134	32.767	0.003	0.003
57184	12&CLAY3 115.00	17.271	17.271	17.272	17.272	0.001	0.001
57186	29 GAGE3 115.00	18.305	18.305	18.306	18.306	0.001	0.001
57187	27CROCO3 115.00	21.379	21.379	21.380	21.380	0.001	0.001
57188	27CROCJ3 115.00	20.976	20.976	20.978	20.978	0.002	0.002
57192	HOOKJCT3 115.00	23.875	23.529	23.877	23.531	0.002	0.002
57212	BROWNCO3 115.00	2.630	2.630	2.632	2.632	0.002	0.002
57217	KELLY 3 115.00	7.996	7.996	8.017	8.017	0.021	0.021
57219	TONGATP3 115.00	13.425	13.077	13.425	13.077	0.000	0.000
57234	BISMARK3 115.00	17.094	17.094	17.094	17.094	0.000	0.000
57236	COOP 3 115.00	16.546	16.546	16.547	16.547	0.001	0.001
57237	CRAIG J3 115.00	12.234	12.234	12.234	12.234	0.000	0.000
57241	FMC 3 115.00	16.276	16.276	16.276	16.276	0.000	0.000
57243	JAGGARD3 115.00	10.864	10.864	10.864	10.864	0.000	0.000
57244	JARBALO3 115.00	17.937	17.462	17.937	17.462	0.000	0.000
57248	LEC U3 3 115.00	28.180	26.239	28.180	26.240	0.000	0.001
57250	LWRNCHL3 115.00	35.768	33.006	35.768	33.006	0.000	0.000
57252	MIDLAND3 115.00	28.169	26.044	28.169	26.044	0.000	0.000
57253	MOCKBRD3 115.00	17.191	17.191	17.191	17.191	0.000	0.000
57261	PENTAGN3 115.00	14.020	14.020	14.020	14.020	0.000	0.000
57269	STULL 3 115.00	12.662	12.662	12.663	12.663	0.001	0.001
57270	STULL T3 115.00	12.785	12.785	12.785	12.785	0.000	0.000
57271	SWLWRNC3 115.00	18.090	17.974	18.090	17.974	0.000	0.000
57282	MUND 3 115.00	12.584	12.428	12.584	12.429	0.000	0.001
57322	BAILEYV3 115.00	4.700	4.700	4.705	4.705	0.005	0.005
57331	KING HL3 115.00	5.985	5.985	5.993	5.993	0.008	0.008
57332	KNOB HL3 115.00	4.763	4.763	4.764	4.764	0.001	0.001
57337	SENECA 3 115.00	5.360	5.360	5.367	5.367	0.007	0.007
57338	SMITTYV3 115.00	4.329	4.329	4.332	4.332	0.003	0.003
57443	COLINE 1 34.500	4.470	4.160	4.470	4.160	0.000	0.000

57448	TEC 1	13.800	14.199	13.169	14.199	13.170	0.000	0.001
57452	LEC 1	34.500	2.448	2.249	2.448	2.249	0.000	0.000
57456	COLINE 2	69.000	10.422	9.982	10.422	9.982	0.000	0.000
57457	DEERCRK2	69.000	11.096	11.041	11.096	11.041	0.000	0.000
57458	ROCKCRK2	69.000	4.145	4.145	4.145	4.145	0.000	0.000
57460	SANTAFJ2	69.000	12.090	11.777	12.090	11.777	0.000	0.000
57462	TEC 2	69.000	17.762	16.517	17.762	16.518	0.000	0.001
57463	TEC GT 2	69.000	16.575	15.392	16.575	15.392	0.000	0.000
57482	VALLEY12	69.000	3.417	3.417	3.417	3.417	0.000	0.000
57496	LEC 2	69.000	5.330	4.889	5.330	4.889	0.000	0.000
57597	MIDIAN 2	69.000	14.184	13.974	14.184	13.974	0.000	0.000
57884	UCB 1	13.800	29.092	26.667	29.092	26.667	0.000	0.000
MIPU			Fault Current (kA) without GEN-2010-041		Fault Current (kA) with GEN-2010-041		Fault Current Increase (kA) with GEN-2010-041	
Rated Interrupting Time			5-cycles		5-cycles		5-cycles	
Contact Parting Time			3-Cycles		3-Cycles		3-Cycles	
BUS			Total¹	Symm²	Total¹	Symm²	Total¹	Symm²
59343	STJOT1Y	161.00	1.969	1.969	1.969	1.969	0.000	0.000
59393	STJOE7	345.00	19.300	18.233	19.301	18.234	0.001	0.001
KCPL			Fault Current (kA) without GEN-2010-041		Fault Current (kA) with GEN-2010-041		Fault Current Increase (kA) with GEN-2010-041	
Rated Interrupting Time			5-cycles		5-cycles		5-cycles	
Contact Parting Time			3-Cycles		3-Cycles		3-Cycles	
BUS			Total¹	Symm²	Total¹	Symm²	Total¹	Symm²
57972	HAWTH 7	345.00	30.876	28.458	30.876	28.458	0.000	0.000
57982	IATAN 7	345.00	24.284	22.385	24.285	22.385	0.001	0.000
58031	GRNWOOD5	161.00	36.404	34.925	36.405	34.925	0.001	0.000
58032	MERRIAM5	161.00	30.344	30.055	30.345	30.055	0.001	0.000
58039	LENEXAN5	161.00	30.397	29.330	30.397	29.330	0.000	0.000
58041	SHAWNEE5	161.00	28.194	27.307	28.194	27.307	0.000	0.000
58049	CEDRCRK5	161.00	30.138	28.883	30.139	28.883	0.001	0.000
KACY			Fault Current (kA) without GEN-2010-041		Fault Current (kA) with GEN-2010-041		Fault Current Increase (kA) with GEN-2010-041	
Rated Interrupting Time			5-cycles		5-cycles		5-cycles	
Contact Parting Time			3-Cycles		3-Cycles		3-Cycles	
BUS			Total¹	Symm²	Total¹	Symm²	Total¹	Symm²
58742	METROP 5	161.00	27.794	26.577	27.794	26.578	0.000	0.001
MEC			Fault Current (kA) without GEN-2010-041		Fault Current (kA) with GEN-2010-041		Fault Current Increase (kA) with GEN-2010-041	
Rated Interrupting Time			5-cycles		5-cycles		5-cycles	

Contact Parting Time			3-Cycles		3-Cycles		3-Cycles	
BUS			Total ¹	Symm ²	Total ¹	Symm ²	Total ¹	Symm ²
63801	CBLUFFS5	161.00	47.223	43.551	47.224	43.551	0.001	0.000
64060	BOONVIL3	345.00	20.976	19.561	20.976	19.561	0.000	0.000
635019	ATCHSN 3	345.00	19.083	17.863	19.084	17.864	0.001	0.001
635020	ATCHSNT3	345.00	19.235	17.997	19.236	17.998	0.001	0.001
NPPD			Fault Current (kA) without GEN-2010-041		Fault Current (kA) with GEN-2010-041		Fault Current Increase (kA) with GEN-2010-041	
Rated Interrupting Time			5-cycles		5-cycles		5-cycles	
Contact Parting Time			3-Cycles		3-Cycles		3-Cycles	
BUS			Total ¹	Symm ²	Total ¹	Symm ²	Total ¹	Symm ²
64020	HARBINE7	115.00	7.992	7.992	7.993	7.993	0.001	0.001
64042	STEELEC7	115.00	4.968	4.968	4.969	4.969	0.001	0.001
64709	COOPER1G	22.000	438.532	403.714	438.550	403.731	0.018	0.017
64741	BEAT. S7	115.00	5.685	5.685	5.686	5.686	0.001	0.001
64742	BEAT. S9	34.500	5.991	5.862	5.992	5.863	0.001	0.001
64743	BEATRCE7	115.00	14.584	14.279	14.586	14.281	0.002	0.002
64744	BEATRCE9	34.500	10.907	10.167	10.907	10.168	0.000	0.001
64773	CLATONA7	115.00	11.018	11.018	11.018	11.018	0.000	0.000
64786	COOPER 3	345.00	35.585	32.752	35.589	32.754	0.004	0.002
64787	COOPER 5	161.00	27.498	25.376	27.508	25.384	0.010	0.008
64815	FAIRBRY7	115.00	5.633	5.580	5.633	5.580	0.000	0.000
64864	HUMBOLT7	115.00	8.211	7.657	8.239	7.683	0.028	0.026
64865	HUMBOLT9	34.500	2.763	2.569	2.764	2.570	0.001	0.001
64896	MCCOOL 3	345.00	10.359	10.044	10.359	10.044	0.000	0.000
64902	MOORE 3	345.00	21.466	20.018	21.466	20.020	0.000	0.001
64933	PAULINE3	345.00	7.179	6.973	7.179	6.973	0.000	0.000
64959	SHELDON7	115.00	37.447	34.660	37.448	34.662	0.001	0.001
64973	STEINER7	115.00	4.865	4.865	4.869	4.869	0.004	0.004
65024	COOPER Y	345.00	14.822	13.589	14.828	13.593	0.006	0.004
65033	HUMBLT Y	161.00	5.891	5.492	5.912	5.512	0.021	0.020
65036	MOORE Y	345.00	251.363	251.363	251.459	251.459	0.096	0.096
65051	BEATGT1G	13.800	94.645	87.266	94.646	87.267	0.001	0.001
65052	BEATGT2G	13.800	94.663	87.289	94.664	87.290	0.001	0.001
65053	BEATST3G	13.800	99.477	91.512	99.478	91.514	0.001	0.001
65054	BPS SUB7	115.00	20.848	19.441	20.850	19.443	0.002	0.002
65061	COOPER 2Y	345.00	14.822	13.589	14.828	13.593	0.006	0.004
65566	S966 8	69.000	0.522	0.493	0.522	0.493	0.000	0.000
LES			Fault Current (kA) without GEN-2010-041		Fault Current (kA) with GEN-2010-041		Fault Current Increase (kA) with GEN-2010-041	

Rated Interrupting Time		5-cycles		5-cycles		5-cycles	
Contact Parting Time		3-Cycles		3-Cycles		3-Cycles	
BUS		Total ¹	Symm ²	Total ¹	Symm ²	Total ¹	Symm ²
65720	NW68HOL3 345.00	15.392	14.461	15.393	14.462	0.001	0.001
65789	SELINC 3 345.00	20.459	19.161	20.460	19.161	0.001	0.000
OPPD		Fault Current (kA) without GEN-2010-041		Fault Current (kA) with GEN-2010-041		Fault Current Increase (kA) with GEN-2010-041	
Rated Interrupting Time		5-cycles		5-cycles		5-cycles	
Contact Parting Time		3-Cycles		3-Cycles		3-Cycles	
BUS		Total ¹	Symm ²	Total ¹	Symm ²	Total ¹	Symm ²
64722	AUBURN 8 69.000	4.748	4.567	4.750	4.569	0.002	0.002
64789	CORNFLD8 69.000	2.040	2.040	2.041	2.041	0.001	0.001
64863	HUMBOLT5 161.00	9.103	8.759	9.146	8.788	0.043	0.029
64914	NEHAWKA8 69.000	4.963	4.963	4.964	4.964	0.001	0.001
64987	TEKAMAHA5 161.00	9.235	9.235	9.235	9.235	0.000	0.000
65301	FT CAL1G 22.000	231.083	212.016	231.083	212.017	0.000	0.001
65302	NEBCTY1G 18.000	336.888	310.114	336.890	310.117	0.002	0.003
65303	N OMA 1G 13.800	92.492	85.197	92.492	85.198	0.000	0.001
65304	N OMA 2G 13.800	142.045	130.031	142.045	130.031	0.000	0.000
65305	N OMA 3G 13.800	135.371	124.162	135.371	124.162	0.000	0.000
65306	N OMA 4G 15.000	153.271	140.612	153.272	140.612	0.001	0.000
65307	N OMA 5G 20.000	132.129	120.954	132.129	120.954	0.000	0.000
65308	JONES 1G 13.800	69.355	63.767	69.355	63.767	0.000	0.000
65309	JONES 2G 13.800	69.302	63.717	69.302	63.717	0.000	0.000
65310	SCBSD G 4.2000	25.680	23.711	25.680	23.711	0.000	0.000
65311	SARPY 1G 13.800	62.494	57.420	62.494	57.420	0.000	0.000
65312	SARPY 2G 13.800	62.846	57.744	62.846	57.744	0.000	0.000
65313	SARPY 3G 13.800	119.105	109.402	119.105	109.402	0.000	0.000
65314	SARPY 4G 13.800	64.030	58.952	64.030	58.952	0.000	0.000
65315	SARPY 5G 13.800	64.150	59.062	64.150	59.062	0.000	0.000
65316	CASS 1G 15.000	165.758	150.235	165.758	150.235	0.000	0.000
65317	CASS 2G 15.000	166.146	150.581	166.146	150.581	0.000	0.000
65322	NEBCTY2G 23.000	294.110	270.237	294.112	270.238	0.002	0.001
65330	SARP4&5T 161.00	23.830	21.835	23.830	21.835	0.000	0.000
65334	S3451T3T 345.00	20.096	18.700	20.097	18.700	0.001	0.000
65335	S3451T4T 345.00	20.125	18.727	20.125	18.727	0.000	0.000
65336	S1254T1T 345.00	17.389	16.181	17.389	16.181	0.000	0.000
65337	S3455T1T 345.00	37.449	36.331	37.451	36.332	0.002	0.001
65338	S3456T4T 345.00	12.408	11.247	12.408	11.247	0.000	0.000
65339	S3459T3T 345.00	24.913	23.230	24.913	23.231	0.000	0.001

65351	S3451 3	345.00	26.470	24.481	26.471	24.480	0.001	-0.001
65354	S3454 3	345.00	28.579	26.651	28.580	26.651	0.001	0.000
65355	S3455 3	345.00	34.426	32.056	34.426	32.055	0.000	-0.002
65356	S3456 3	345.00	39.961	36.998	39.962	36.999	0.001	0.001
65358	S3458 3	345.00	35.083	32.375	35.084	32.377	0.001	0.001
65359	S3459 3	345.00	26.893	25.068	26.894	25.068	0.001	0.000
65360	S3740 3	345.00	21.766	20.105	21.766	20.105	0.000	0.000
65380	S1201T1T	161.00	14.285	13.307	14.285	13.307	0.000	0.000
65381	S1206T1T	161.00	20.093	18.420	20.093	18.420	0.000	0.000
65382	S1206T2T	161.00	17.897	16.504	17.897	16.504	0.000	0.000
65383	S1209T1T	161.00	19.384	18.066	19.384	18.066	0.000	0.000
65384	S1210T7T	161.00	15.292	14.608	15.292	14.608	0.000	0.000
65385	S1211T1T	69.000	35.251	32.627	35.251	32.627	0.000	0.000
65386	S1214T1T	161.00	5.006	4.725	5.006	4.725	0.000	0.000
65387	S1217T1T	161.00	13.411	12.502	13.411	12.502	0.000	0.000
65388	S1221T9T	161.00	13.598	12.678	13.598	12.678	0.000	0.000
65389	S1250T1T	161.00	13.048	11.955	13.048	11.955	0.000	0.000
65390	S1263T1T	161.00	72.930	72.930	72.331	72.331	-0.599	-0.599
65391	S975T4 T	161.00	5.423	5.055	5.443	5.072	0.020	0.018
65392	S3455T3T	345.00	50.289	50.077	50.291	50.079	0.002	0.002
65401	S1201 5	161.00	34.335	32.606	34.336	32.606	0.001	0.000
65405	S1305 5	161.00	31.223	29.111	31.223	29.111	0.000	0.000
65406	S1206 5	161.00	55.936	51.619	55.937	51.621	0.001	0.001
65409	S1209 5	161.00	44.245	41.256	44.246	41.257	0.001	0.001
65410	S1210 5	161.00	29.281	28.210	29.282	28.210	0.001	0.000
65411	S1211 5	161.00	43.690	40.693	43.691	40.694	0.001	0.001
65414	S1214 5	161.00	11.784	11.784	11.784	11.784	0.000	0.000
65416	S1216 5	161.00	32.594	30.392	32.595	30.392	0.001	0.000
65417	S1217 5	161.00	34.926	32.927	34.926	32.927	0.000	0.000
65420	S1220 5	161.00	30.406	29.314	30.407	29.314	0.001	0.000
65421	S1221 5	161.00	34.087	33.285	34.087	33.286	0.000	0.001
65422	S1222 5	161.00	28.867	27.828	28.867	27.828	0.000	0.000
65426	S1226 5	161.00	24.769	23.995	24.770	23.995	0.001	0.000
65427	S1227 5	161.00	32.911	31.629	32.912	31.630	0.001	0.001
65429	S1229 5	161.00	30.618	29.258	30.618	29.258	0.000	0.000
65431	S1231 5	161.00	42.023	40.018	42.024	40.019	0.001	0.001
65432	S1232 5	161.00	26.884	26.550	26.884	26.551	0.000	0.001
65433	S1233 5	161.00	27.846	27.084	27.846	27.084	0.000	0.000
65434	S1234 5	161.00	25.075	24.644	25.075	24.644	0.000	0.000
65435	S1235 5	161.00	30.209	29.547	30.209	29.547	0.000	0.000

65436	S1236 5 161.00	18.156	18.113	18.156	18.113	0.000	0.000
65437	S1237 5 161.00	17.892	17.892	17.892	17.892	0.000	0.000
65441	S1341 5 161.00	30.847	28.761	30.847	28.761	0.000	0.000
65443	S1343 5 161.00	27.113	26.358	27.113	26.358	0.000	0.000
65444	S1244 5 161.00	21.810	21.201	21.811	21.202	0.001	0.001
65445	S1345 5 161.00	15.653	15.653	15.653	15.653	0.000	0.000
65448	S1248 5 161.00	21.205	21.205	21.205	21.205	0.000	0.000
65449	S1249 5 161.00	23.510	22.561	23.510	22.562	0.000	0.001
65450	S1250 5 161.00	36.882	35.621	36.882	35.622	0.000	0.001
65451	S1251 5 161.00	38.720	35.929	38.720	35.929	0.000	0.000
65452	S1252 5 161.00	19.945	19.905	19.945	19.905	0.000	0.000
65453	S1253 5 161.00	24.517	24.241	24.517	24.242	0.000	0.001
65454	S1254 5 161.00	31.703	29.520	31.704	29.521	0.001	0.001
65455	S1255 5 161.00	48.921	45.519	48.921	45.519	0.000	0.000
65456	S1256 5 161.00	21.126	20.896	21.126	20.896	0.000	0.000
65457	S1357 5 161.00	26.825	26.825	26.825	26.825	0.000	0.000
65458	S1258 5 161.00	6.060	6.060	6.063	6.063	0.003	0.003
65459	S1259 5 161.00	34.753	33.080	34.754	33.080	0.001	0.000
65460	S1260 5 161.00	26.845	26.379	26.845	26.380	0.000	0.001
65463	S1263 5 161.00	8.592	8.533	8.605	8.544	0.013	0.011
65478	S1278 5 161.00	26.055	25.867	26.056	25.867	0.001	0.000
65480	S1280 5 161.00	11.145	10.862	11.174	10.884	0.029	0.022
65481	S1281 5 161.00	26.262	25.356	26.262	25.356	0.000	0.000
65486	S1286 5 161.00	28.274	27.392	28.275	27.393	0.001	0.001
65487	S1287 5 161.00	18.146	18.135	18.147	18.135	0.001	0.000
65497	S1297 5 161.00	19.500	19.148	19.500	19.148	0.000	0.000
65498	S1298 5 161.00	32.686	30.472	32.686	30.472	0.000	0.000
65499	S1299 5 161.00	30.374	29.162	30.375	29.162	0.001	0.000
65500	S900 8 69.000	8.050	8.050	8.050	8.050	0.000	0.000
65501	S901 8 69.000	31.892	29.739	31.892	29.739	0.000	0.000
65502	S902 8 69.000	8.680	8.680	8.680	8.680	0.000	0.000
65504	S904 8 69.000	8.845	8.845	8.845	8.845	0.000	0.000
65507	S907 8 69.000	20.205	20.182	20.205	20.183	0.000	0.001
65508	S908 8 69.000	19.613	19.613	19.613	19.613	0.000	0.000
65509	S909 8 69.000	30.195	28.160	30.195	28.160	0.000	0.000
65510	S910 8 69.000	27.650	26.879	27.651	26.880	0.001	0.001
65511	S911 8 69.000	31.673	29.491	31.674	29.491	0.001	0.000
65512	S912 8 69.000	22.495	22.419	22.496	22.419	0.001	0.000
65513	S913 8 69.000	18.188	18.188	18.188	18.188	0.000	0.000
65514	S914 8 69.000	7.791	7.791	7.791	7.791	0.000	0.000

65516	S916 8 69.000	24.153	23.759	24.153	23.759	0.000	0.000
65517	S917 8 69.000	28.383	26.469	28.383	26.469	0.000	0.000
65518	S918 8 69.000	23.223	23.223	23.223	23.223	0.000	0.000
65519	S919 8 69.000	22.497	22.497	22.497	22.497	0.000	0.000
65521	S921 8 69.000	27.820	26.144	27.820	26.144	0.000	0.000
65523	S923 8 69.000	19.125	19.125	19.125	19.125	0.000	0.000
65524	S924 8 69.000	24.011	23.491	24.011	23.491	0.000	0.000
65528	S928 8 69.000	15.639	15.639	15.639	15.639	0.000	0.000
65530	S930 8 69.000	22.045	22.045	22.045	22.045	0.000	0.000
65537	S937 8 69.000	8.489	8.489	8.489	8.489	0.000	0.000
65538	S938 8 69.000	22.366	22.366	22.366	22.366	0.000	0.000
65539	S939 8 69.000	20.532	20.532	20.532	20.532	0.000	0.000
65540	S940 8 69.000	20.942	20.875	20.942	20.875	0.000	0.000
65542	S942 8 69.000	15.293	15.293	15.293	15.293	0.000	0.000
65546	S6846 8 69.000	7.386	7.386	7.386	7.386	0.000	0.000
65550	S950 8 69.000	25.420	23.629	25.420	23.629	0.000	0.000
65561	S961 8 69.000	5.092	5.092	5.092	5.092	0.000	0.000
65562	S962 8 69.000	5.769	5.769	5.770	5.770	0.001	0.001
65563	S963 8 69.000	10.511	10.346	10.519	10.353	0.008	0.007
65564	S964 8 69.000	3.423	3.423	3.424	3.424	0.001	0.001
65565	S965 8 69.000	7.077	7.077	7.087	7.087	0.010	0.010
65567	S967 8 69.000	5.079	5.079	5.080	5.080	0.001	0.001
65568	S968 8 69.000	4.457	4.457	4.457	4.457	0.000	0.000
65569	S969 8 69.000	4.409	4.409	4.409	4.409	0.000	0.000
65570	S970 8 69.000	4.351	4.351	4.351	4.351	0.000	0.000
65571	S971 8 69.000	4.812	4.812	4.812	4.812	0.000	0.000
65572	S972 8 69.000	4.421	4.421	4.421	4.421	0.000	0.000
65573	S973 8 69.000	3.623	3.623	3.624	3.624	0.001	0.001
65574	S974 8 69.000	5.609	5.609	5.609	5.609	0.000	0.000
65575	S975 8 69.000	12.671	11.817	12.711	11.854	0.040	0.037
65576	S976 8 69.000	11.158	10.525	11.158	10.525	0.000	0.000
65577	S977 8 69.000	6.362	6.362	6.364	6.364	0.002	0.002
65579	979TP 8 69.000	6.678	6.678	6.678	6.678	0.000	0.000
65582	S982 8 69.000	4.000	4.000	4.000	4.000	0.000	0.000
65583	S983 8 69.000	7.214	7.214	7.214	7.214	0.000	0.000
65584	S984 8 69.000	7.627	7.627	7.627	7.627	0.000	0.000
65585	S985 8 69.000	8.351	8.351	8.351	8.351	0.000	0.000
65588	S988 8 69.000	2.973	2.973	2.973	2.973	0.000	0.000
65590	990TP 8 69.000	4.001	4.001	4.001	4.001	0.000	0.000
65591	991TP 8 69.000	10.019	9.912	10.019	9.912	0.000	0.000

65592	S992 8 69.000	5.884	5.884	5.884	5.884	0.000	0.000
65593	S993 8 69.000	2.612	2.553	2.613	2.553	0.001	0.000
65594	S994 8 69.000	12.766	12.766	12.766	12.766	0.000	0.000
65595	S995 8 69.000	12.832	12.832	12.832	12.832	0.000	0.000
65600	S906 N 8 69.000	36.573	34.068	36.573	34.068	0.000	0.000
65601	S906 S 8 69.000	37.638	34.811	37.638	34.811	0.000	0.000
65604	S914A 8 69.000	12.015	11.908	12.015	11.908	0.000	0.000
65605	915TP3 8 69.000	13.282	13.282	13.282	13.282	0.000	0.000
65606	915TP9 8 69.000	12.276	12.276	12.276	12.276	0.000	0.000
65607	S915T2 8 69.000	9.608	9.608	9.608	9.608	0.000	0.000
65608	S915T1 8 69.000	11.735	11.735	11.735	11.735	0.000	0.000
65609	S979 8 69.000	6.545	6.545	6.545	6.545	0.000	0.000
65610	S990 8 69.000	2.914	2.914	2.914	2.914	0.000	0.000
65611	S991 8 69.000	8.593	8.593	8.593	8.593	0.000	0.000
65615	ASH GRV8 69.000	6.972	6.972	6.972	6.972	0.000	0.000
65616	AUBRNT 8 69.000	6.732	6.732	6.737	6.737	0.005	0.005
65617	HYDCAP 8 69.000	4.522	4.522	4.522	4.522	0.000	0.000
65618	ENRON 8 69.000	4.380	4.380	4.380	4.380	0.000	0.000
65619	MUD LNG8 69.000	15.077	15.077	15.077	15.077	0.000	0.000
65621	JCT205 8 69.000	22.892	22.663	22.892	22.663	0.000	0.000
65622	PAX MIT8 69.000	11.615	11.615	11.615	11.615	0.000	0.000
65623	SAC623 8 69.000	11.996	11.996	11.996	11.996	0.000	0.000
65624	SAC629 8 69.000	11.695	11.695	11.695	11.695	0.000	0.000
65625	SAC SO 8 69.000	7.912	7.912	7.912	7.912	0.000	0.000
65626	SAC NO 8 69.000	9.992	9.992	9.992	9.992	0.000	0.000
65627	W BROCK8 69.000	11.558	11.060	11.568	11.068	0.010	0.008
65650	TECUMSH8 69.000	3.142	3.043	3.142	3.043	0.000	0.000
65652	NCU903 8 69.000	6.230	6.223	6.231	6.223	0.001	0.000
65653	NC SYRA8 69.000	4.378	4.378	4.379	4.379	0.001	0.001
65654	FREM 6G 13.800	23.669	21.458	23.669	21.458	0.000	0.000
65655	FREM A 8 69.000	15.104	13.956	15.104	13.956	0.000	0.000
65656	FREM B 8 69.000	10.307	9.650	10.307	9.650	0.000	0.000
65657	FREM D 8 69.000	11.120	10.541	11.120	10.541	0.000	0.000
65658	FREM E 8 69.000	8.696	8.524	8.696	8.524	0.000	0.000
65659	FREM F 8 69.000	9.806	9.237	9.806	9.237	0.000	0.000
65660	FREM 7G 13.800	23.745	21.529	23.745	21.529	0.000	0.000
65661	FREM 8G 13.800	69.607	63.604	69.607	63.604	0.000	0.000
65662	FREM 1G 13.800	46.673	42.807	46.673	42.807	0.000	0.000
65663	FREM C 8 69.000	9.636	9.415	9.636	9.415	0.000	0.000
65664	FREM G 8 69.000	13.723	12.786	13.723	12.786	0.000	0.000

65665	S3455T19	13.800	23.476	21.597	23.476	21.597	0.000	0.000
65666	S3456T49	13.800	25.563	23.582	25.563	23.582	0.000	0.000
65667	S1211T19	13.800	33.842	31.513	33.842	31.513	0.000	0.000
65668	S3455T39	13.800	40.005	36.738	40.005	36.738	0.000	0.000
65670	FC1A	5 161.00	34.855	32.442	34.855	32.442	0.000	0.000
65671	FC1A1	9 4.2000	29.999	28.488	29.999	28.488	0.000	0.000
65672	FC1A2	9 4.2000	29.770	28.259	29.770	28.259	0.000	0.000
65673	FC1A3	9 4.2000	23.492	21.894	23.492	21.894	0.000	0.000
65674	FC1A4	9 4.2000	23.588	21.988	23.588	21.988	0.000	0.000
65675	NBAXT1	9 4.2000	53.223	50.689	53.223	50.689	0.000	0.000
65676	NBAXT2	9 4.2000	52.810	50.388	52.810	50.388	0.000	0.000
65677	NBHST1	9 4.2000	25.715	24.015	25.717	24.016	0.002	0.001
65678	NBHST2	9 4.2000	25.936	24.330	25.938	24.332	0.002	0.002
65679	NBHST3	9 4.2000	26.320	24.629	26.322	24.631	0.002	0.002
65680	NBHST4	9 4.2000	26.133	24.421	26.135	24.422	0.002	0.001
65681	NO1 AUX	9 2.4000	37.873	34.798	37.873	34.798	0.000	0.000
65682	NO2 AUX	9 2.4000	34.866	32.038	34.866	32.038	0.000	0.000
65683	NO3 AUX	9 2.4000	45.429	41.729	45.429	41.729	0.000	0.000
65684	NO4 AUX	9 2.4000	43.552	40.040	43.552	40.040	0.000	0.000
65685	NO5 AUX	9 4.2000	48.087	44.174	48.087	44.174	0.000	0.000
65686	S911 HS	9 13.800	9.404	8.789	9.404	8.789	0.000	0.000
65687	S1211HS	9 13.800	9.069	8.384	9.069	8.384	0.000	0.000
580071	G10-041GEN	1 0.69	0.000	0.000	331.732	304.949	331.732	304.949
645061	FLTWTR1W	0.5750	0.000	1099.440	0.000	1136.557	0.000	37.117
646399	S1399	5 161.00	7.652	7.586	7.758	7.663	0.106	0.077
648500	FLTWTRX	9 34.500	16.281	15.161	17.496	16.288	1.215	1.127
648501	FLTWTRY	9 13.800	23.452	21.740	24.090	22.307	0.638	0.567

Note 1: For Breakers Rated on a Total Current Basis

Note 2: For Breakers Rated on a Symmetrical Current Basis